

PRE-ANNEXATION AGREEMENT

by and between

CITY OF HUNTINGTON BEACH

and

COUNTY OF ORANGE

PRE-ANNEXATION AGREEMENT
BY AND BETWEEN
COUNTY OF ORANGE
AND
CITY OF HUNTINGTON BEACH

THIS PRE-ANNEXATION AGREEMENT ("Agreement"), is entered into by and among the COUNTY OF ORANGE ("County"), and the CITY OF HUNTINGTON BEACH ("City") (collectively referred to as the "Parties" herein).

1. RECITALS OF PREMISES, PURPOSE AND INTENT

1.1 Background

1.1.1 On July 8, 2009, the ORANGE COUNTY LOCAL AGENCY FORMATION COMMISSION ("LAFCO") approved the update of Huntington Beach's Sphere of Influence to include the unincorporated area of Sunset Beach. The community is substantially surrounded by the City of Huntington Beach to the north, east, and south. It is bordered predominately by the Pacific Ocean to the west.

1.1.2 On June 29, 2010, the City of Huntington Beach filed an application with LAFCO to annex the unincorporated community of Sunset Beach. The draft application requests LAFCO to consider annexation of approximately 110 acres of inhabited territory to the City of Huntington Beach.

1.1.3 On August 2, 2010, the City of Huntington Beach City Council approved the preparation of all the necessary documents required for application to LAFCO for annexation of the unincorporated County of Orange community of Sunset Beach.

1.1.4 The County and the City enter into this Agreement with reference to the proposed annexation by the City of the County of Orange community of Sunset Beach which is within City's sphere of influence.

1.1.5 Revenue and Taxation Code Section 99 provides that prior to the effective date of any jurisdictional change, the affected agencies of such change shall negotiate the amount of property tax revenues to be exchanged.

1.1.6 The City and County have met and negotiated both a property tax exchange and other consideration upon recordation of the annexation.

1.1.7 The County has adopted, and the California Coastal Commission has approved or certified, the Sunset Beach Specific Plan/Local Coastal Program (LCP), Land Use Plan (LUP) and other documents governing development in Sunset Beach which is subject to the Coastal Act ("Coastal Zone Area"). Under the circumstances present in this case, it is appropriate for the County to retain, for an interim period, jurisdiction to issue coastal development permits for the Coastal Zone Area subsequent to City's annexation of the Sunset Beach community, unless the Coastal Commission asserts independent permitting authority.

1.1.8 In order to maintain continuity of services and avoid public confusion while the City seeks approval for adding the Sunset Beach area to the City's Local Coastal Plan (LCP), following annexation, the City and County shall set forth a reasonable, equitable and fair arrangement for the application of Land Use Regulations in the area annexed and for the continued processing of projects. The City has requested to contract planning services with the County until the California Coastal Commission (Coastal Commission) has approved adding Sunset Beach into the City's LCP.

1.1.9 The City and County are public entities possessing the common power to review and approve applications for administrative and ministerial permits for development, including subdivision maps, conditional use permits, grading permits and building permits, and other approvals related to the development of real property. The City and County also have the common power to accept dedications, impose exactions, and to develop and maintain recreational and public facilities pursuant to provisions of State and/or local law. Government Code Sections 51300, et seq., authorize a county to contract for the performance of municipal functions common to both agencies by county officers and employees. This Agreement fully complies with all State statutory and constitutional provisions related to the transfer of municipal functions from a city to a county.

1.2 Purpose

The purpose of this Agreement is to provide more efficient provision of municipal services to Sunset Beach. The parties have determined that annexation of Sunset Beach would benefit both the City and Sunset Beach. Policies of the LAFCO favor the annexation of unincorporated areas so as to encourage the orderly and efficient provision of municipal services. The City has the capacity to provide all required municipal services to Sunset Beach. The annexation of Sunset Beach to the City will also be of an economic benefit to the City, including increased property and sales tax revenues.

1.3 Environmental Review

The City shall act as lead agency for the Sunset Beach reorganization (Orange County LAFCO Application IA 10-05 and shall be responsible for preparation of all environmental documentation required under CEQA thereto.

2. DEFINITIONS

For purposes of this Agreement, except as otherwise expressly provided or unless the context otherwise requires:

2.1 "City" means the City of Huntington Beach, California.

2.2 "Code" means the Huntington Beach Municipal Code.

2.3 "Community" means the approximately 134 acres of Sunset Beach. The legal description of Sunset Beach is set forth in Exhibit A, and a depiction of Sunset Beach is set forth in Exhibit B.

2.4 “Council” or “City Council” means the City Council of the Huntington Beach.

2.5 “County” means the County of Orange.

2.6 “Director” means the Director of Planning of the City.

2.7 “Effective Date” shall be the date of recordation of the LAFCO Resolution approving the Annexation.

2.8 “Interim Period” is defined as the period between the effective date of annexation and approval by the California Coastal Commission of the transfer of Local Coastal Plan authority to the City of Huntington Beach.

2.9 “LAFCO” means the Orange County Local Agency Formation Commission.

2.10 “Land Use Authority” means the power and authority to accept applications for, process, review, approve conditionally approve, modify, amend and/or disapprove any and all land use entitlements, building permits and development approvals. “Land Use Authority” also includes the authority and right to inspect any construction work and improvement as normally conducted by a city to determine compliance with any development approval, and to issue a final clearance or certificate of occupancy.

2.11 “Land Use Regulations” includes all applicable laws, statutes, ordinances, regulations and official policies governing or related to the permitted uses of land, the density or intensity of use, the needed parking, patio/open space and year requirements, the maximum height and size of proposed buildings, the conversion of apartments to condominiums, the subdivision requirements, all of the adopted Building Codes, the inclusion of affordable housing units, reservation or dedication of land for public purposes, exactions, and the design, improvement and construction standards and specifications applicable to the County’s Sunset Beach Specific Plan/Local Coastal Plan.

2.12 “Local Coastal Plan” means the County’s Sunset Beach Specific Plan/Local Coastal Plan.

2.13 “Proceeding” means any threatened, pending, or compiled claim, cause of action, civil liability, action, suit, arbitration, alternate dispute resolution process, investigation, administrative hearing, appeal or any other proceeding, whether civil, criminal, administrative, investigative or any other type whatsoever

2.14 “Zoning Ordinance” means the Huntington Beach Zoning and Subdivision Ordinance as it exists on the Effective Date.

3. TERMS AND CONDITIONS

3.1 Terms & Conditions. Based on the foregoing and in consideration of the parties’ mutual agreements and promises hereinafter set forth, the sufficiency of which is hereby acknowledged, the parties agree as follows

3.1.1 Property Tax Exchange. Upon completion of the annexation of Sunset Beach by the City, the City and County agree to the following exchange of property tax revenue:

3.1.1.1. The property taxes generated from the annexation area will be exchanged in the same proportions as set out in Master Tax Agreement 80-2093 between the City and the County dated October 28, 1980; to wit: the City will receive 55.9617 percent and the County will receive 44.0383 percent; and

3.1.1.2. The City will receive one hundred percent (100%) of the Structural Fire Fund and Library Fund generated from the annexation area.

3.1.2 Ocean Lifeguard Services. Upon completion of the annexation of Sunset Beach by City, County shall assign and City shall accept County's Ocean Lifeguard Services contract. After such assignment, the County shall have no further duties or obligations under the Ocean Lifeguard Services contract. County shall provide City funding of the Ocean Lifeguard Services contract for a period of two (2) years. City shall be responsible to administer the Ocean Lifeguard Services contract for Sunset Beach. The assignment of the Ocean Lifeguard Services contract shall be implemented through the attached Assignment, Novation and Consent Agreement in Exhibit C.

3.1.2.1 County shall provide funding to the City in an amount equal to two (2) years of funding for the Contract. Upon execution of this Agreement, City shall submit an invoice to County for the two (2) years of funding and County shall pay said invoice within ninety (90) days of submittal.

3.1.3 Beach Sanitizer. Upon the effective date of the annexation of Sunset Beach by the City, the County shall transfer ownership of County's Beach Sanitizer Unit 9155 (Fixed Asset No. 70461) to City at no cost to City.

3.1.4 Utility Undergrounding Projects. The County has agreed to continue its work on two (2) utility undergrounding projects.

3.1.4.1 Rule 20A. The County agrees to continue to coordinate with Southern California Edison on their project to convert overhead utilities to underground facilities on Pacific Coast Highway through construction completion.

3.1.4.2 Underground Assessment District Project. The County agrees to provide up-front funding to this project, in the form of a loan, for the cost of the Engineering Report and will be reimbursed with interest in the amount provided by law, by homeowner assessment fees, when approved by the residents without regard to whether such approval occurs before or after the date of annexation. Upon annexation, the City shall take over responsibility of the formation of the Assessment District and completion of the undergrounding project. If the formation of an Assessment District, has not been completed on the date of

annexation the City and County will enter into an agreement which will provide for transfer of the Assessment District process without regard to the status of the process on that date to the City as of the date of annexation. The agreement will provide for reimbursement of any funds the County may advance toward this project as well as interest on such sums in the amount provided by law, in the event that the residents approve the assessment.

3.1.5 Resurfacing Project. The County agrees to complete a pavement resurfacing or slurry project of specified streets and alleys in Sunset Beach subject to the completion of the Rule 20A Utility Undergrounding Project. If necessary, the City and County will enter into an agreement to address the completion of the project if it is not complete on the date of the recordation of the annexation. The specified streets are included as Exhibit D of the Agreement.

3.1.6 Broadway Bridge Repair. The County agrees to complete a spall repair project of the bridge, once necessary permits have been obtained. Should one be required, the City shall provide the County with any permit(s), at no fee or cost, for the project. A summary of the project is included in Exhibit D.

3.1.7 Land Use Authority. The City agrees to contract with the County, for an interim period, for planning services until the Coastal Commission approves City LCP authority for Sunset Beach.

3.1.7.1 The Parties, through this Agreement intend that the County have and exercise after annexation the same power, right and control over the administration, approval and implementation of land use, over the Sunset Beach community that the County exercised before annexation. The Parties also intend that the County shall exercise land use and other authority in substantial conformance with the Sunset Beach Specific Plan/Local Coastal Program in effect as of the Effective Date of this Agreement.

3.1.7.2 By this Agreement, the City transfers to the County, for the Interim Period, the power and authority to review, approve, conditionally approve, modify, amend and/or disapprove Development Approvals and Land Use Regulations with respect to the Sunset Beach community as set forth in the Sunset Beach Specific Plan/Local Coastal Program (Land Use Authority). This Land Use Authority includes routine code enforcement, the review and approval of all plans and specifications for development, the issuance of all grading and building permits, all inspections of structures and improvements, and the enforcement of ordinances relating to construction, grading, erosion control and site cleanup and occupancy.

3.1.7.3 During the Interim Period, the County shall exercise Land Use Authority in substantial compliance with the provisions of the Sunset Beach Specific Plan/Local Coastal Program, conditions imposed by any State or local agency; and legally enforceable restrictions and limitations on development of the Property.

3.1.7.4 If, at any time after the recordation of the certificate of completion of the annexation of the Sunset Beach community, the City of Huntington Beach elects to assume coastal management responsibility for the Annexed Area, the city may begin preparation of a local coastal program for that area. The City of Huntington Beach may adopt provisions of the County of Orange's certified local coastal program that apply to the Annexed Area.

3.1.7.5 If the City of Huntington Beach obtains certification of a local coastal program for the Annexed Area, the city shall, upon the effective date of that certification, exercise all of the authority granted to a local government with a certified local coastal program, and the provisions of paragraph (3.1.7.4) shall become inoperative.

3.1.7.6 City agrees that County shall be entitled to charge, receive and retain all fees charged pursuant to the retention of Land Use Authority. County shall be entitled to charge, receive and retain all customary fees including planning application, building permit fees, grading fees, and inspection fees. The fees charged by the County shall be the County's sole consideration for all services performed and the exercise of all authority transferred pursuant to this Agreement. The fees charged by the County shall also be the County's sole consideration for the transfer of records as specified in this Agreement.

3.1.8 Records. The County and City shall use their best efforts to transfer property documents promptly so as to minimize delays in development of projects. Records shall be transferred electronically to the greatest extent possible.

3.1.9 County Officers. The County Executive Officer ("CEO") shall designate the County officers, employees and contractors that are to perform the services contemplated by, and exercise the authority contracted pursuant to, this Agreement. The Parties agree that the

CEO will designate the same officers, employees and contractors that have, prior to the effective date of this Agreement, been performing services or exercising powers related to Land Use Authority.

3.1.10 **Transfer of Permits and Deeds.** The County shall transfer and the City shall accept all valid landside and waterway encroachment permits, as well as quitclaim deeds for the Sunset Beach area (see Exhibit E), which will be subject to the City's ordinances. The City's acceptance is contingent upon the completion of the annexation and will be completed no later than sixty (60) days from the date that the annexation becomes final. The City, County and LAFCO make no representation in regard to the position, if any, of the Coastal Commission in relation to these permits.

3.1.11 **Coordination of Fire Code Plan Review and Fire Code Inspections.** Upon effective date of annexation, the City shall coordinate with the Orange County Fire Authority as to which entity will be responsible for Fire Code plan review and Fire Code Inspections of County-approved permits during the interim period.

3.1.12 **Ambulance Service Area.** The County will work with the City in an effort to place Sunset Beach into the City's Exclusive Operating Area for ambulance services.

3.1.13 **Transfer of Facilities.** The County will transfer facilities in Sunset Beach to the City upon annexation including, but not limited to: streets, lights, traffic signals, signs, etc. A listing is included as Exhibit F.

3.2 Terms & Conditions (Specific to Sunset Beach)

3.2.1 The City of Huntington Beach and the County of Orange will use their best efforts to maintain the identity of Sunset Beach

3.2.2 The City of Huntington Beach will not change any current Sunset Beach street names and addresses except as necessary for public safety purposes.

3.2.3 The Huntington Beach City Council will form a committee comprised of three City Council members who will meet regularly with the Sunset Beach community to discuss and address issues distinct to Sunset Beach.

3.2.4 The City of Huntington Beach will maintain the greenbelt generally located west of Pacific Coast Highway between North Pacific and South Pacific Avenues as a community park including all existing parking spaces and infrastructure.

4. GENERAL PROVISIONS

4.1 Cooperation and Implementation

4.1.1 Implementation. City represents that it will cooperate with the community of Sunset Beach and the County of Orange to the fullest extent reasonable and feasible to

implement this Agreement. The County shall, in a timely manner, provide City with all documents, plans and other information necessary for City to carry out its obligations hereunder.

4.1.2 Cooperation. In addition to any other requirements of this Agreement, the City agrees to make its best efforts to undertake the actions set forth in this Section 4.1, provided such actions shall not result in any cost or expense to the City (other than overhead and employee staff time).

4.2 Cooperation in Legal Action.

In the event of any legal action instituted by a third party (not a party to this Agreement) or any governmental entity or official (other than the City or an official of the City or the County or an official of the County), challenging the validity of any provision of this Agreement, or any discretionary action relating to this Agreement or the annexation, the parties hereby agree to cooperate in defending said action; provided, however, and shall each indemnify and hold the other harmless, as more specifically provided in Section 4.10 of this Agreement, from all damages and litigation expenses, including reasonable attorneys' fees and costs, arising out of any legal action instituted by such third party (not a party to this Agreement), or other governmental entity or official, including, but not limited to, any action brought by the Sunset Beach Community Association relating to the provision of services to Sunset Beach, in connection with such action. City or County shall promptly notify the other and LAFCO of any such action and shall cooperate in the defense thereof.

4.3 Enforceability

4.3.1 Default. Subject to Section 4.3.2, failure by any party to perform any term or provision of this Agreement required to be performed by such party shall constitute an event of default ("Event of Default"). For purposes of this Agreement, a party claiming another party is in default shall be referred to as the "Complaining Party," and the party alleged to be in default shall be referred to as the "Party in Default." A Complaining Party shall not exercise any of its remedies as the result of such Event of Default unless such Complaining Party first gives notice to the Party in Default as provided in Section 4.3.2, and the Party in Default fails to cure such Event of Default within the applicable cure period.

4.3.2 Procedure Regarding Defaults.

4.3.2.1 Notice Required. The Complaining Party shall give written notice of default to the Party in Default, specifying the default complained of by the Complaining Party. Delay in giving such notice shall not constitute a waiver of any default nor shall it change the time of default.

4.3.2.2 Right to Cure. The Party in Default shall diligently endeavor to cure, correct or remedy the matter complained of, provided such cure, correction or remedy shall be completed within the applicable time period set forth herein after receipt of written notice (or such additional time as may be deemed by the Complaining Party to be reasonably necessary to correct the matter).

4.3.2.3 Delay not a Waiver. Any failures or delays by a Complaining Party in asserting any of its rights and remedies as to any Event of Default shall not operate as a waiver of any Event of Default or of any such rights or remedies. Delays by a Complaining Party in asserting any of its rights and remedies shall not deprive the Complaining Party of its right to institute and maintain any actions or proceedings which it may deem necessary to protect, assert, or enforce any such rights or remedies.

4.3.2.4 Time to Cure. If an Event of Default occurs, prior to exercising any remedies, the Complaining Party shall give the Party in Default written notice of such Event of Default in accordance with Section 4.4 below. If the Default is reasonably capable of being cured within thirty (30) days of the Party in Default's receipt of such written notice, the Party in Default shall have such period to effect a cure prior to exercise of remedies by the Complaining Party. If the nature of the alleged Default is such that it cannot practicably be cured within such 30 day period, the cure shall be deemed to have occurred within such 30 day period if (i) the cure is commenced at the earliest practicable date following receipt of the notice; (ii) the cure is diligently prosecuted to completion at all times thereafter; (iii) at the earliest practicable date (in no event later than 30 days after the curing party's receipt of the notice), the curing party provides written notice to the other party that the cure cannot practicably be completed within such 30 day period; and (iv) the cure is completed at the earliest practicable date. In no event shall the Complaining Party be precluded from exercising remedies if a Default is not cured within one hundred eighty (180) days after the first notice of default is given.

4.3.2.5 Termination of Agreement. Subject to the foregoing, if a Party in Default fails to cure an Event of Default in accordance with the foregoing, the Complaining Party, at its option, may terminate this Agreement, and/or institute legal proceedings pursuant to this Agreement.

4.3.3 Institution of Legal Action. Subject to notice of default and opportunity to cure under Sections 4.3.1 and 4.3.2, in addition to any other rights or remedies, any party to this Agreement may institute legal action to cure, correct or remedy any default, to enforce any covenants or agreements herein, to enjoin any threatened or attempted violation hereof, or to obtain any other remedies consistent with this Agreement.

4.4 Notices

All notices or other communications required hereunder shall be in writing and shall be personally delivered (including by means of professional messenger service), or sent by registered or certified mail, postage prepaid, return receipt required, or by electronic facsimile transmission followed by delivery of a "hard" copy, and shall be deemed received on the date of receipt thereof. Unless otherwise indicated in writing, such notice shall be sent addressed as follows:

If to the City:

City Administrator
City of Huntington Beach
2000 Main Street
Huntington Beach, California 92648

With a copy to:

City Attorney
City of Huntington Beach
2000 Main Street
Huntington Beach, California 92648

If to the County of Orange:

County of Orange
County Executive Office
333 W. Santa Ana Blvd.
Santa Ana, CA 92701
Attn: Steve Dunivent, Deputy County Executive Officer

With a copy to:

County Executive Office
333 W. Santa Ana Blvd.
Santa Ana, CA 92701
Attn: Jay Wong, Administrative Manager

4.5 No Third Party Beneficiaries

This Agreement is made and entered into for the sole protection and benefit of the parties and their successors and assigns. No other person shall have any right of action based upon any provision of this Agreement.

4.6 Time of Essence

Time is of the essence for each provision of this Agreement of which time is an element.

4.7 Modification, Amendment or Extension

Subject to any notice and hearing requirements imposed by law, this Agreement may be modified, amended and/or extended from time to time by mutual written consent of the City and County.

4.8 Conflict with State or Federal Laws.

In the event that state or federal laws or regulations enacted after this Agreement has been entered into prevent or preclude compliance with one or more provisions of this Agreement (a) the party prevented from performance shall provide the other party with written notice of such state or federal restriction and a statement of the conflict with the provisions of this Agreement, and (b) County and the City staff shall, within thirty (30) days, meet and confer in good faith in a reasonable attempt to modify this Agreement, but only to the minimum extent necessary to comply with such federal or state law or regulation. Thereafter, regardless of whether the parties reach an agreement on the effect of such law or regulation upon this Agreement, the matter shall be scheduled for hearing before the City Council. Ten (10) days' written notice of such hearing shall be given, pursuant to Government Code Section 65854.5. The City Council, at such hearing, shall determine the exact modification or suspension which shall be necessitated by such federal or state law or regulation. County, at the hearing, shall have the right to offer oral and written testimony. Any modification or suspension shall be taken by the affirmative vote of not less than a majority of the authorized voting members of the City Council and shall be subject to the concurrence of County.

4.9 Cooperation in Securing Permits. The City shall cooperate with the County in the securing of any permits which may be required as a result of such modifications or suspensions.

4.10 Indemnity

4.10.1 Definition. As used in this Section 4.10, "Proceeding" means any threatened, pending, or compiled claim, cause of action, civil liability, action, suit, arbitration, alternate dispute resolution process, investigation, administrative hearing, appeal or any other proceeding, whether civil, criminal, administrative, investigative or any other type whatsoever.

4.10.2 By the City of the County. The City shall indemnify and defend the County, its officers, employees and agents (County Indemnites), against and hold the County Indemnites harmless from all claims, demands, liabilities, damages, losses, costs and expenses, including reasonable attorneys' fees and disbursements, arising from or related to this agreement.

4.10.3 By the County of the City. The County shall indemnify and defend the City, its officers, employees and agents (City Indemnites), against and hold the City Indemnites harmless from all claims, demands, liabilities, damages, losses, costs and expenses, including reasonable attorneys' fees and disbursements, arising from or related to this agreement.

4.10.4 Application to Damages. This indemnification and hold-harmless agreement applies to all damages and claims for damages suffered or alleged to have been suffered by reason of the activities and development referred to in this Agreement, regardless of whether or not the City or County prepared, supplied, or approved plans or specifications, or both. A party's obligation to indemnify the other party pursuant to this Section 4.10 applies to all proceedings, damages and claims for damages suffered or alleged to have been suffered by the other party by reason of the activities of the indemnifying party referred to in this Agreement, regardless of whether or not the City or County prepared, supplied, or approved plans or specifications, or both, for such activities, including, but not limited to, damages caused by

concurrent active or passive negligence, active negligence, and willful misconduct of the indemnifying party, its officers, employees and agents. However, the indemnifying party shall have no obligation to indemnify the other party for damages caused by the active negligence, sole negligence, or willful misconduct of the other party, or its officers, employees, and agents. This indemnity shall apply to all claims and liability regardless of whether any insurance policies are applicable. The policy limits do not act as limitation upon the amount of indemnification to be provided.

4.10.5 Defense. The party providing the indemnity will conduct all defense at its sole cost and expense and the indemnified party shall approve selection of counsel, provided that such approval shall not be unreasonably withheld.

4.11 Waiver

No waiver of any provision of this Agreement shall be effective unless in writing and signed by a duly authorized representative of the party against whom enforcement of a waiver is sought and referring expressly to this Section. No waiver of any right or remedy in respect of any occurrence or event shall be deemed a waiver of any right or remedy in respect of any other occurrence or event.

4.12 Successors and Assigns

Except as expressly provided to the contrary in this Agreement, the burdens and obligations of this Agreement shall be binding upon, and the benefits of this Agreement shall inure to, all successors in interest to the parties to this Agreement and all successors in interest to Sunset Beach or any portion thereof or any interest therein, and shall be covenants running with the land.

4.13 Governing State Law

This Agreement shall be construed in accordance with the laws of the State of California.

4.14 Constructive Notice and Acceptance

Every person who now or hereafter owns or acquires any right, title or interest in or to any portion of Sunset Beach is and shall be conclusively deemed to have consented and agreed to every provision contained herein, whether or not any reference to this Agreement is contained in the instrument by which such person acquired an interest in Sunset Beach.

4.15 Covenant of Good Faith and Fair Dealing

No party shall do anything which shall have the effect of harming or injuring the right of the other party to receive the benefits of this Agreement.

4.16 Covenant of Cooperation

The County and the City shall cooperate with and assist each other in the performance of the provisions of this Agreement, including assistance in obtaining permits for the development

of Sunset Beach which may be required from public agencies other than the City. The County and the City reserve the right to challenge any ordinance, measure, moratorium or other limitation in a court of law if it becomes necessary to protect the rights vested in Sunset Beach.

4.17 Further Actions and Instruments

The parties to this Agreement shall cooperate with and provide reasonable assistance to the other parties to the extent contemplated in the performance of all obligations under this Agreement and the satisfaction of the conditions of the Agreement.

4.18 Section Headings

All Article and Section headings and subheadings are inserted for convenience only and shall not affect any construction or interpretation of this Agreement.

4.19 Enforced Delay (Force Majeure)

4.19.1 Force Majeure Defined. In addition to specific provisions of this Agreement, performance by any party hereunder shall not be deemed to be in default where delays or defaults are due to war, insurrection, strikes, walkouts, riots, floods, earthquakes, fires, casualties, acts of God, enactment of conflicting state or federal laws or regulations (but only if the party claiming delay complies at all times with the provisions of this Agreement pertaining to such conflicting laws), litigation brought by any third party (not a party to this Agreement), or similar bases for excused performance due to causes beyond the control of and without the fault of the party claiming an extension of time to perform.

4.19.2 Notice Requirement. An extension of time for any such cause (a “Force Majeure Delay”) shall be for the period of the enforced delay and shall commence to run from the time of the commencement of the cause, if notice by the party claiming such extension is sent to the other parties within thirty (30) days of knowledge of the commencement of the cause. Notwithstanding the foregoing, none of the foregoing events shall constitute a Force Majeure Delay unless and until the party claiming such delay and interference delivers to the other party written notice describing the event, its cause, when and how such party obtained knowledge, the date the event commenced, and the estimated delay resulting therefrom. Any party claiming a Force Majeure Delay shall deliver such written notice within thirty (30) days after it obtains actual knowledge of the event. Times of performance under this Agreement may also be extended in writing by the City.

4.19.3 Exception. Notwithstanding the first sentence of Section 4.19.2, the following shall apply: (i) The County shall be entitled to a Force Majeure Delay for a period longer than the period of enforced delay if the City Council determines that such longer period is reasonably required; and (ii) The County shall be entitled to a Force Majeure Delay notwithstanding the fact that the County may not have given timely notice to the City, if the City Council determines that such Force Majeure Delay is reasonably required.

4.20 Severability

Invalidation of any of the provisions contained in this Agreement, or of the application thereof to any person, by judgment or court order, shall in no way affect any of the other provisions hereof or the application thereof to any other person or circumstance, and the same shall remain in full force and effect, unless enforcement of this Agreement, as so invalidated, would be unreasonable or inequitable under all the circumstances or would frustrate the purposes of this Agreement and/or the rights and obligations of the parties hereto.

4.21 Interpretation

The language in all parts of this Agreement shall in all cases be construed simply, as a whole and in accordance with its fair meaning and not strictly for or against any party. The parties hereto acknowledge and agree that this Agreement has been prepared jointly by the parties and has been the subject of arm's length and careful negotiation over a considerable period of time, that each party has independently reviewed this Agreement with legal counsel, and that each party has the requisite experience and sophistication to understand, interpret and agree to the particular language of the provisions hereof. Accordingly, in the event of an ambiguity in or dispute regarding the interpretation of this Agreement, this Agreement shall not be interpreted or construed against the party preparing it, and instead other rules of interpretation and construction shall be utilized.

4.22 Counterparts

This Agreement may be executed in duplicate counterpart originals, each of which is deemed to be an original and all of which when taken together shall constitute one and the same instrument.

4.23 Entire Agreement

This Agreement consists of fourteen (15) pages and exhibits (designated "A" through "F"), which constitute the entire understanding and agreement of the parties.

IN WITNESS WHEREOF, the parties have each executed this Agreement on NOVEMBER 15, 2010.

COUNTY OF ORANGE, a municipal corporation of the State of California

Janet Quynh

Chair, Board of Supervisors

CITY OF HUNTINGTON BEACH, a municipal corporation of the State of California

Cathy Green

Mayor

ATTEST:

Joan A. Bloom
Clerk of the Board of Supervisors

Joan D. Flynn
City Clerk

APPROVED AS TO FORM:

[Signature]
County Counsel

APPROVED AS TO FORM:

James M. [Signature]
City Attorney 11.9.10

INITIATED AND APPROVED:

[Signature]
Deputy City Administrator

REVIEWED AND APPROVED:

[Signature]
City Administrator

FACSIMILE SIGNATURE AUTHORIZED PER G.C.SEC. 26103, RESO 79-1535 SIGNED AND CERTIFIED THAT A COPY OF THIS DOCUMENT HAS BEEN DELIVERED TO THE CHAIR OF THE BOARD



ATTEST:
Joan A. Bloom
DARLENE J. BLOOM
CLERK OF THE BOARD OF SUPERVISORS
ORANGE COUNTY, CALIFORNIA

**Exhibit A
(Legal Description)**

EXHIBIT A
PROPOSED "SUNSET BEACH ANNEXATION (AN 10-__)"

That portion of fractional Section 24, Township 5 South, Range 12 West, and those portions of fractional Sections 19 and 30, Township 5 South, Range 11 West, of the San Bernardino Meridian, in the County of Orange, State of California according to the official plat of said land filed in the District Land Office described as follows:

Beginning at the northerly terminus of that certain course in the boundary line of the City of Huntington Beach as established by City Annexation in Ordinance No. 920 of said city shown as having a bearing and distance of "South 21° 43' 12" West, 249.38 feet", said northerly terminus also being the most easterly corner of Tract No. 21 as per map recorded in Book 9, Page 22 of Miscellaneous Maps, in the office of the County Recorder of said County; thence along said City Boundary Line the following courses:

Course 1: South 21°43' 12" West a distance of 249.38 feet,

Course 2: South 07°56'07" West a distance of 53.74 feet to a point being in a curve concave to the northeast having a radius of 2940 feet; a radial line of said curve from said point bears North 44°12'36" East,

Course 3: Southeasterly a distance of 63.71 feet along last mentioned curve through a central angle of 01°14'30",

Course 4: South 47°01'54" East a distance of 279.29 feet to the beginning of a tangent curve concave to the southwest having a radius of 3060 feet,

Course 5: Southeasterly a distance of 195.23 feet along said last mentioned curve through a central angle of 03°39'20",

Course 6: South 43°22'34" East a distance of 1599.82 feet to the beginning of a tangent curve concave to the southwest having a radius of 3050 feet,

Course 7: Southeasterly a distance of 183.58 feet along said last mentioned curve through a central angle of 03°26'55", to a point on a line parallel with and 30.00 feet southerly, measured at right angles, from the centerline of Los Patos Avenue (Warner Avenue) as said centerline is shown on a map filed in Book 53, Page 40 of Records of Survey in the office of said County Recorder, said point being the most southwesterly corner in the boundary line of the City of Huntington Beach as established by City Annexation in Ordinance No. 3489 of said city; thence leaving said city boundary,

Course 8: South 89°51'53" West a distance of 377.41 feet along said parallel line to a point in the boundary line of the City of Huntington Beach as established by City Annexation in Ordinance No. 1126 of said city, said point also being southeasterly along said City Boundary line 40.61 feet from the northwesterly terminus of that certain course shown as having a bearing and distance of "North 42°28'13" West, 1816.06 feet"; thence along said City Boundary Line,

EXHIBIT A
PROPOSED "SUNSET BEACH ANNEXATION (AN 10-__)"

Course 9: North 43°23'54" West a distance of 40.61 feet,

Course 10: South 89°51'53" West a distance of 291.59 feet,

Course 11: South 49°10'33" West a distance of 344.56 feet to a point in the Mean High Tide Line of the Pacific Ocean as shown on Record of Survey 2010-1097 recorded in Book 241, Page 3 in the office of the County Recorder of said County, said point also being the southeasterly terminus of that certain course shown as having a bearing and distance of "North 41°43'52" West, 388.69 feet"; thence along said Mean High Tide Line the following courses:

Course 12: North 42°38'49" West a distance of 388.69 feet,

Course 13: North 44°46'59" West a distance of 1085.55 feet,

Course 14: North 44°33'21" West a distance of 1283.71 feet,

Course 15: North 43°44'38" West a distance of 1709.89 feet,

Course 16: North 41°23'09" West a distance of 968.62 feet,

Course 17: North 47°20'53" West a distance of 703.78 feet to a point in the southeasterly City Boundary Line of the City of Seal Beach, County of Orange, State of California, said boundary having been established as Annexation No. 76-1 to said city, said point also being distant southwesterly along said City Boundary line 368.70 feet from the easterly corner of said Annexation No. 76-1; thence leaving said Mean High Tide Line and along said City Boundary Line,

Course 18: North 49°35'36" East a distance of 368.70 feet to the most easterly corner of said Annexation No. 76-1, said corner also being the most southerly corner in said city boundary established as Annexation No. 67-1 to said city; thence along said City Boundary Line,

Course 19: North 49°35'36" East a distance of 511.00 feet to the most westerly corner in the boundary line of the City of Huntington Beach as established by City Annexation in Ordinance No. 919 of said city, said corner being in a curve concave to the southwest having a radius of 1060 feet, a radial line of said curve from said point bears South 25°58'14" West (South 26°05'34" West per said Ordinance No. 919); thence along said City Boundary Line the following courses:

Course 20: Southeasterly a distance of 380.17 feet along said last mentioned curve through a central angle of 20°32'58",

EXHIBITA
PROPOSED "SUNSET BEACH ANNEXATION (AN 10-__)"

Course 21: South 43°28'48" East a distance of 389.02 feet to the beginning of a tangent curve concave to the southwest having a radius of 1060 feet,

Course 22: Southeasterly a distance of 341.40 feet along said last mentioned curve through a central angle of 18°27'12",

Course 23: South 25°01'36" East a distance of 63.84 feet to the beginning of a tangent curve concave to the northeast having a radius of 940 feet,

Course 24: Southeasterly a distance of 117.68 feet along said last mentioned curve through a central angle of 07°10'23",

Course 25: South 32°11'59" East a distance of 35.23 feet to the beginning of a tangent curve concave to the northeast having a radius of 940 feet,

Course 26: Southeasterly a distance of 186.20 feet along said last mentioned curve through a central angle of 11°20'58",

Course 27: South 43°32'57" East a distance of 563.44 feet along to the beginning of a tangent curve concave to the northeast having a radius of 940 feet,

Course 28: Southeasterly a distance of 136.93 feet along said last mentioned curve through a central angle of 08°20'46",

Course 29: South 51°53'43" East a distance of 179.28 feet to the most southerly corner of said Ordinance No. 919 of said city,

Course 30: North 46°31'47" East a distance of 323.43 feet to the most easterly corner of said Ordinance No. 919 of said city, said corner also being a point along that certain course in the southwesterly boundary line of the City of Huntington Beach as established by City Annexation in Ordinance No. 800 of said city, a distance of 1008.96 feet from the northwesterly terminus of that certain course shown as having a bearing and distance of "North 42°45'00" West, 2727.12 feet"; thence along said City Boundary Line,

Course 31: South 42°28'34" East a distance of 980.00 feet to the most northerly corner in the boundary line of the City of Huntington Beach as established by City Annexation in Ordinance No. 1089 of said city; thence along said City Boundary Line,

Course 32: South 46°45' 11" West a distance of 55.00 feet,

Course 33: South 43°14'49" East a distance of 375.00 feet,

Course 34: North 46°45'11" East a distance of 15.00 feet,

Course 35: South 43°14'49" East a distance of 111.77 feet,

EXHIBIT A
PROPOSED "SUNSET BEACH ANNEXATION (AN 10-__)"

Course 36: North 75°46'26" East a distance of 33.80 feet along said City Boundary Line to an intersection with that certain course in the southwesterly boundary line of the City of Huntington Beach as established by City Annexation in Ordinance No. 800 of said city, said intersection also being northwesterly along said southwesterly boundary 261.60 feet from the southeasterly terminus of that certain course shown as having a bearing and distance of "North 42°45'00" West and a length of 2727.12 feet"; thence along said City Boundary Line,

Course 37: South 42°28'34" East a distance of 261.60 feet,

Course 38: South 47°13'34" East a distance of 35.00 feet to the Point of Beginning.

Containing an area of 133.88 acres, more or less.

Attached hereto and made a part hereof is a map designated as *EXHIBIT B*.

SURVEYOR'S CERTIFICATE

This proposal was prepared by me or under my supervision.

Jeremy L. Evans
Jeremy L. Evans, PLS 5282
Expires: December 31, 2011

9-8-2010
Date:



This proposal does meet the approval of the Orange County Surveyor's Office.

Dated this _____ day of _____ 201__.

By: _____
Raymond L. Mathe, County Surveyor
PLS 6185, Expiration Date: March 31, 2012

**Exhibit B
(Depiction)**

EXHIBIT B Proposed "Sunset Beach Annexation" (AN 10-)

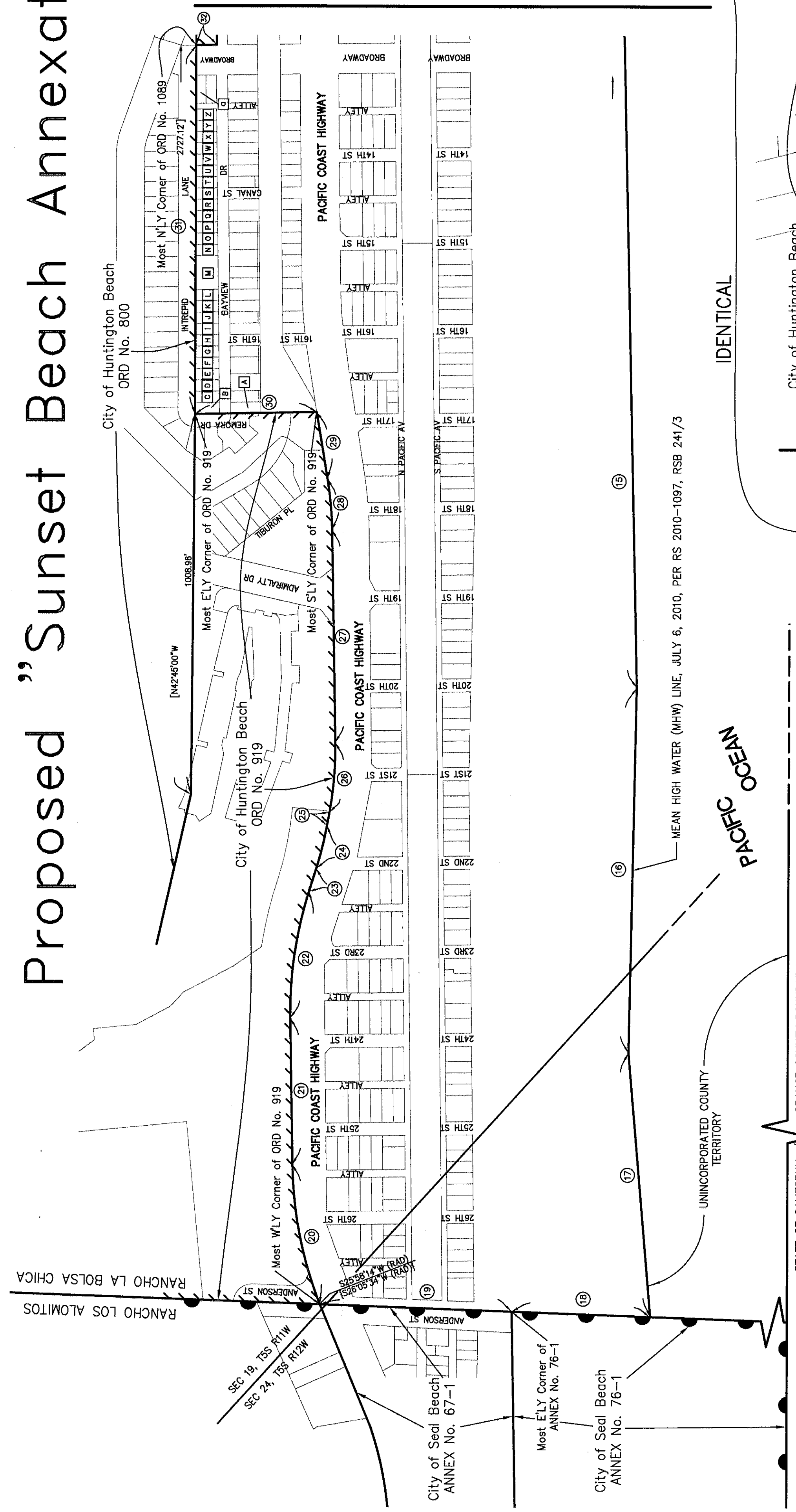

ASSESSOR'S PARCEL NUMBERS	
#	A.P.N.
A	178-561-56
B	178-561-21
C	178-561-22
D	178-561-23
E	178-561-41
F	178-561-40
G	178-561-26
H	178-561-27
I	178-561-28
J	178-561-29
K	178-561-30
L	178-561-31
M	178-561-43
N	178-561-35
O	178-561-36
P	178-561-37
Q	178-561-38
R	178-561-39

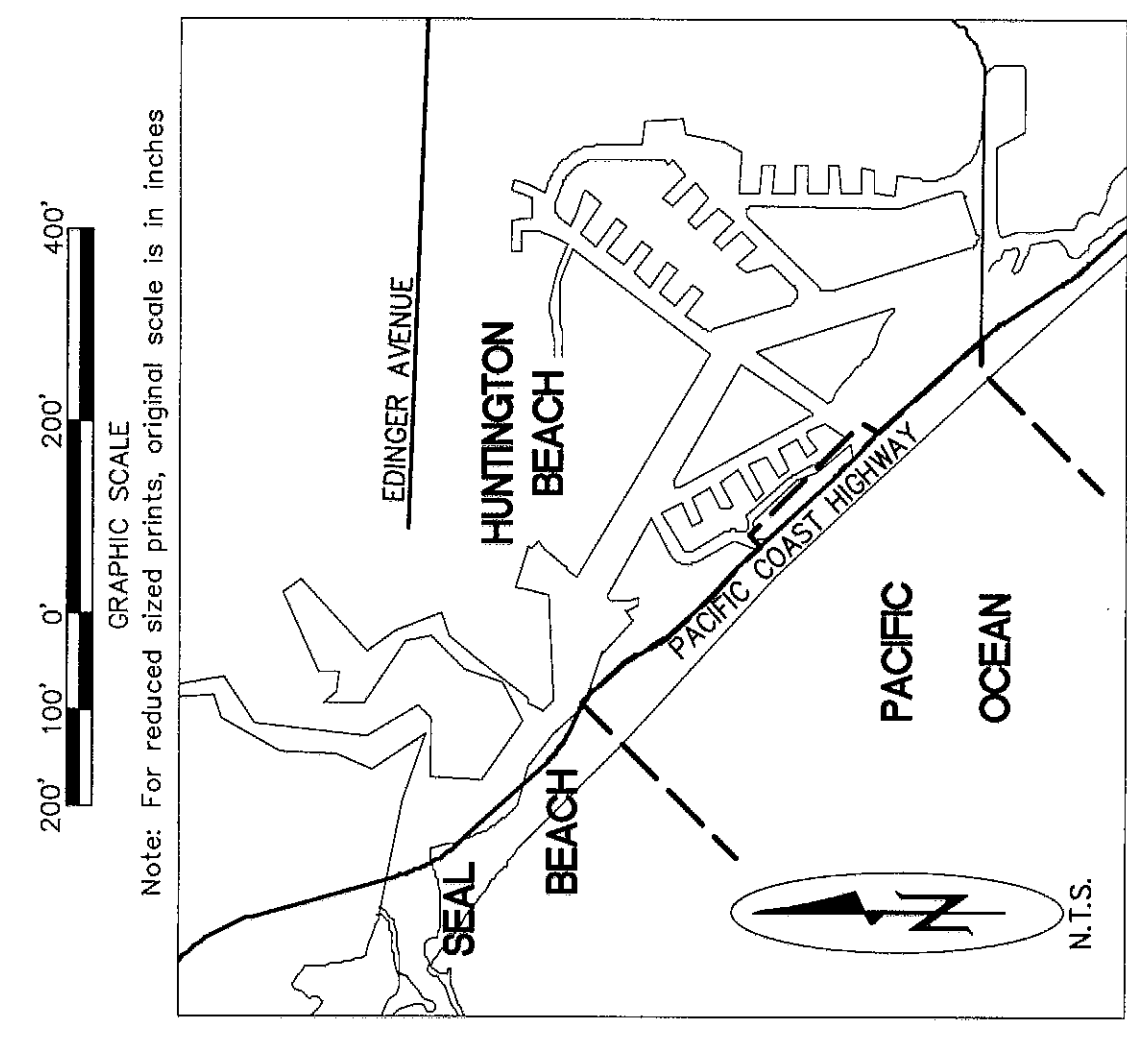
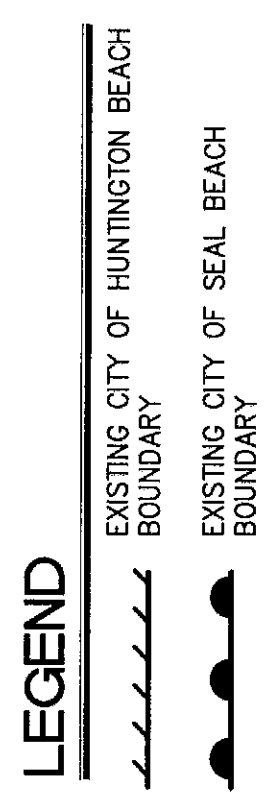

DATA TABLE				
#	BEARING/DELTA	LENGTH	RADIUS	BEARING/DELTA RADIUS LENGTH
1	<< S 21°43'12" W >>	249.38'	20	{20°32'58"} 380.17'
2	<< S 07°56'07" W >>	53.74'	21	{S 43°21'27" E} 398.02'
3	<< 01°4'30" >>	63.71'	22	{16°27'12"} 341.40'
4	<< S 47°01'54" E >>	279.29'	23	{S 24°54'15" E} 63.84'
5	<< 03°39'20" >>	195.23'	24	{07°10'23"} 117.68'
6	<< S 43°22'34" E >>	1599.82'	25	{S 32°04'38" E} 35.23'
7	03°26'55"	183.58'	26	{17°20'58"} 940'
8	S 89°51'53" W	377.41'	27	{S 43°25'36" E} 563.44'
9	(N 42°28'13" W)	40.81'	28	{08°20'46"} 136.93'
10	(N 89°12'26" W)	291.59'	29	{S 51°46'22" E} 179.28'
11	(S 50°06'14" W)	344.56'	30	{N 46°39'09" E} 323.43'
12	(N 41°43'52" W)	368.69'	31	{S 42°45'00" E} 980.00'
13	(N 43°52'02" W)	1085.55'	32	{N 46°28'45" E} 55.00'
14	(N 42°49'41" W)	1283.71'	33	{S 43°31'15" E} 375.00'
15	(N 42°49'41" W)	1709.89'	34	{N 46°28'45" E} 15.00'
16	(N 40°28'12" W)	968.62'	35	{S 43°31'15" E} 111.77'
17	(N 47°25'09" W)	703.78'	36	{N 46°28'45" E} 33.80'
18	(N 50°30'33" E)	368.70'	37	{S 42°45'00" E} 261.60'
19	(N 49°28'00" E)	511.00'	38	{S 47°30'00" E} 35.00'

BASIS OF BEARINGS
The northwesterly line of parcel 2 as described in Ordinance Number 920 having a bearing of S 21°43'12" W is the basis of bearing.

- REFERENCE**
- () RECORD PER ORD. No. 1126 TO CITY OF HUNTINGTON BEACH
 - [] RECORD PER ORD. No. 800 TO CITY OF HUNTINGTON BEACH
 - { } RECORD PER ORD. No. 919 TO CITY OF HUNTINGTON BEACH
 - (()) RECORD PER ANNEX No. 67-1 & 76-1 TO CITY OF SEAL BEACH
 - [[] RECORD PER RS 2010-1097, RSB 241/3
 - < > RECORD PER ORD. No. 1089 TO CITY OF HUNTINGTON BEACH
 - << >> RECORD PER ORD. No. 920 TO CITY OF HUNTINGTON BEACH

COUNTY SURVEYOR'S STATEMENT
This proposal does meet the approval of the Orange County Surveyor's Office

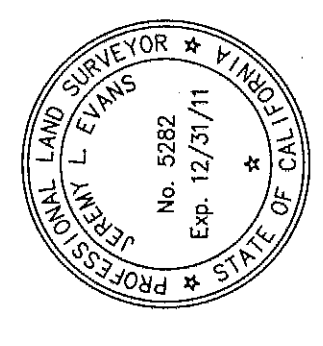

SURVEYOR'S STATEMENT
This proposal was prepared by me or under my supervision
JEREMY L. EVANS
EXPIRATION DATE: DECEMBER 31, 2011
DATE: 11-01-10

THIS PARCEL CONTAINS A LAND AREA OF 133.88 ACRES +/-.

CITY OF HUNTINGTON BEACH / RIGHT OF WAY ENGINEERING
Proposed "Sunset Beach Annexation" (AN 10-)

PREPARED BY: A.G.R.
CHECKED BY: P.J.F.
SCALE: 1"=200'
DATE: 11/08/2010

Exhibit C
(Assignment, Novation and Consent Agreement)

Agreement No. OCP10-____
Sunset Beach
(Ocean Lifeguard Services)

ASSIGNMENT, NOVATION AND CONSENT AGREEMENT

THIS ASSIGNMENT, NOVATION AND CONSENT AGREEMENT is made as of the ____ day of _____, 2011 ("**Agreement**") by and among the City of Huntington Beach, a municipal corporation, (hereinafter referred to as "**CITY**"), the County of Orange, a political subdivision of the State of California, (hereinafter referred to as "**COUNTY**"), and US Ocean Safety, Inc., a California corporation, (hereinafter referred to as ("**USOS**"). The CITY, COUNTY and USOS are sometimes referred to herein individually as a "**Party**" or collectively as the "**Parties**".

RECITALS

WHEREAS, on _____, 2010, CITY and COUNTY entered into that certain agreement entitled AGREEMENT BETWEEN THE CITY OF HUNTINGTON BEACH AND THE COUNTY OF ORANGE REGARDING THE SUNSET BEACH ANNEXATION TO THE CITY OF HUNTINGTON BEACH ("**Annexation Agreement**") to annex the unincorporated territory referred to as the community of Sunset Beach into CITY; and

WHEREAS, COUNTY and USOS have entered into Contract #MA-012-11010397 (the "**Contract**") for Ocean Lifeguard Services at Sunset Beach, effective January 1, 2011; and

WHEREAS, the Annexation Agreement provides for the COUNTY to assign and for the CITY to accept the Contract; and

WHEREAS, the Parties desire to substitute CITY in place of COUNTY with respect to the Contract.

NOW, THEREFORE, in consideration of the promises hereto and the mutual covenants and agreements set forth herein, the Parties agree as follows:

1. COUNTY does hereby assign, transfer, and convey to CITY as of _____, 2011 (the "Effective Date") all of COUNTY's title, right, obligations, and interest in, to and under the Contract. As of the Effective Date the County shall have no further duties or obligation under the Contract, as more fully set forth in Section 5, below.
2. CITY hereby accepts such assignment of the Contract as of the Effective Date, and agrees to assume all of COUNTY's duties and obligations in, to and under the Contract from and after the Effective Date.
3. USOS acknowledges the substitution and novation of CITY in place and instead of COUNTY from and after the Effective Date, and agrees that as of the Effective Date the Contract shall effectively be between the CITY and USOS and that the County shall have no further duty or obligation hereunder, as more fully set forth in Section 5, below.

4. Except as provided for in the Annexation Agreement, CITY and USOS agree to fully release COUNTY from any and all obligations, responsibilities, and duties under the Contract from and after the Effective Date.
5. CITY agrees to defend and indemnify COUNTY from any and all claims, actions, judgments, liabilities, proceedings and costs, including reasonable attorneys' fees and other costs of defense and damages, resulting from and related to the Contract from and after the Effective Date.
6. COUNTY agrees to defend and indemnify CITY from any and all claims, actions, judgments, liabilities, proceedings and costs, including reasonable attorneys' fees, resulting from and related to COUNTY's performance under the Contract and subject to the terms of the Contract prior to the Effective Date.
7. This Agreement, along with the Annexation Agreement, constitutes the entire agreement concerning the assignment between the Parties and this Agreement may not be modified, altered or amended other than in writing executed all of the Parties.
8. This Agreement may be executed in counterparts, and in such event, the counterpart signatures shall be assembled and shall together constitute a complete agreement.

//
//
//

IN WITNESS WHEREOF, the Parties hereto have executed this Agreement as of the date first written above.

CITY ATTORNEY
City of Huntington Beach

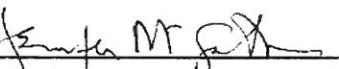
By: 
Date 11-29-10

CITY

City of Huntington Beach, a municipal corporation

By: 
Fred Wilson, City Manager

ATTEST:

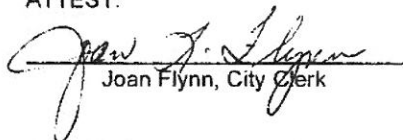

Joan Flynn, City Clerk

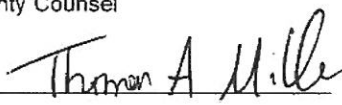
APPROVED AS TO FORM:
County Counsel

By: 
Date 12-15-10

COUNTY

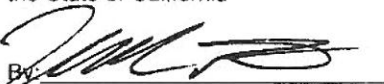
County of Orange, a political subdivision of the State of California

By: 
Mark Denny, Director, OC Parks
Pursuant to Orange County Board of Supervisors Minute Order dated November 29, 2010

USOS

US Ocean Safety, Inc., a California corporation

By: 
By: 

Exhibit D (Planned Projects)

Pavement Project to be Completed

Street	Begin	End	Street Length (ft.)	Type of Maintenance
ALLEY - BTWN 10th & 11th	NORTH PACIFIC AVE	PACIFIC COAST HWY	163	Thin Overlay
ALLEY - BTWN 11th & 12th	NORTH PACIFIC AVE	PACIFIC COAST HWY	162	Thin Overlay
ALLEY - BTWN 12th & BROADWAY	NORTH PACIFIC AVE	PACIFIC COAST HWY	158	Thin Overlay
ALLEY - BTWN 14th & 15th	NORTH PACIFIC AVE	PACIFIC COAST HWY	154	Thin Overlay
ALLEY - BTWN 14th & BROADWAY	N PACIFIC AVE	PACIFIC COAST HWY	165	Thin Overlay
ALLEY - BTWN 15th & 16th	NORTH PACIFIC AVE	PACIFIC COAST HWY	154	Thin Overlay
ALLEY - BTWN 16th & 17th	NORTH PACIFIC AVE	PACIFIC COAST HWY	144	Thin Overlay
ALLEY - BTWN 23rd & 24th	NORTH PACIFIC AVE	PACIFIC COAST HWY	211	Thin Overlay
ALLEY - BTWN 24th & 25th	NORTH PACIFIC AVE	PACIFIC COAST HWY	206	Thin Overlay
ALLEY - BTWN 26th & ANDERSON STREET	N PACIFIC AVE	PACIFIC COAST HWY	919	Thin Overlay
ALLEY - BTWN 3rd & 4th	NORTH PACIFIC AVE	PACIFIC COAST HWY	106	Thin Overlay
ALLEY - BTWN 6th & 7th	N PACIFIC AVE	PACIFIC COAST HWY	194	Thin Overlay
ALLEY - BTWN 7th & 8th	N PACIFIC AVE	PACIFIC COAST HWY	178	Thin Overlay
ANDERSON STREET	SOUTH PACIFIC AVE	PACIFIC COAST HWY	260	Thin Overlay + Traffic Loops
FIFTEENTH STREET	NORTH PACIFIC AVE	PACIFIC COAST HWY	160	Thin Overlay
FOURTEENTH STREET	NORTH PACIFIC AVE	PACIFIC COAST HWY	156	Thin Overlay + New Longitudinal Gutter
NINETEENTH STREET	NORTH PACIFIC AVE	PACIFIC COAST HWY	106	Thin Overlay + Traffic Loops
PASCHALLS LANE	NORTH PACIFIC AVE	PACIFIC COAST HWY	192	Thin Overlay
SEVENTEENTH STREET	NORTH PACIFIC AVE	PACIFIC COAST HWY	106	Thin Overlay
SEVENTH STREET	PACIFIC COAST HWY	END	264	Thin Overlay
SIXTEENTH STREET	PACIFIC COAST HWY	END	370	Thin Overlay
TENTH STREET	NORTH PACIFIC AVE	PACIFIC COAST HWY	158	Thin Overlay
TWELFTH STREET	NORTH PACIFIC AVE	PACIFIC COAST HWY	166	Thin Overlay
WARNER AVENUE	PACIFIC AVE	COAST HWY	317	Reconstruction w/PCC from North Pacific to end. Overlay of .20' from PCH to North Pacific.

Broadway Bridge Repair Project to be Completed

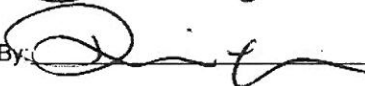
- The bridge repair project involves the patching of concrete spalls (i.e. exposed rebar). Spalling is generally due to rebar corrosion in a marine environment.
- Repairs will consist of concrete removal, surface preparation, formwork (if necessary), and application of repair material such as concrete. The proposed project will repair the following:
 - 1) Exterior face of deck spall,
 - 2) Bent cap spalls, and
 - 3) Deck expansion joint spalls.
- Commencement of project is contingent upon acquiring the necessary California Coastal Commission permit (tentatively expected in FY 2012-13).
- Inclusion of a no fee permit to the County, from the City of Huntington Beach, is requested, to conduct the repair work.

**Exhibit E
(Quitclaim Deed)**

Recording requested by and
when recorded, return to:
City of Huntington Beach
2000 Main St.
P.O. Box 190
Huntington Beach, CA 92648
Attn: City Clerk

Recording Fee Exempt
Per Government Code 27383

Facility: Various
A.P. No.: Various

QUITCLAIM DEED

For valuable consideration, receipt of which is hereby acknowledged, the

COUNTY OF ORANGE,
hereinafter referred to as "COUNTY",

does hereby remise, release and forever Quitclaim to the

CITY OF HUNTINGTON BEACH,
a municipal corporation,
hereinafter referred to as "CITY",

all right, title and interest in and to the real property in the Unincorporated Territory of the
County of Orange, State of California, described as:

See EXHIBIT "A"
attached and by reference made a part.

Parcels GA 1014-1, GA 1014-3(a) and GA 1014-3(b) shall be used for park purposes in
perpetuity.

COUNTY makes no warranty, express or implied, as to the quality of title conveyed hereby.
CITY, by acceptance of this deed, agrees that this conveyance is subject to all licenses, leases,
liens, easements, restrictions, conditions, covenants, encumbrances and claims of title which may
affect said property whether recorded or not.

COUNTY OF ORANGE

Dated: _____

By: _____
Chairman of the Board of Supervisors

Approved as to form
County of Orange
County Counsel

SIGNED AND CERTIFIED THAT A COPY OF
THIS DOCUMENT HAS BEEN DELIVERED
TO THE CHAIRMAN OF THE BOARD.

By: _____
Deputy

Darlene J. Bloom
Clerk of the Board of Supervisors
of Orange County, California

Date: _____

State of California) ss.
County of Orange)

On _____, 19___ before me, _____ a Notary
Public, personally appeared _____ personally known
to me (or proved to me on the basis of satisfactory evidence) to be the person whose name
is subscribed to the within instrument and acknowledged to me that he/she executed the
same in his/her authorized capacity, and that by his/her signature on the instrument the
person, or the entity upon behalf of which the person acted, executed the instrument.

WITNESS my hand and official seal.

Signature of the Notary

EXHIBIT A

Attachment B

Those certain interests dedicated to the COUNTY OF ORANGE for street and highway, public parking and public use in the Unincorporated Territory of the County of Orange, State of California per the following documents recorded in Miscellaneous Maps (M.M.), Parcel Map Book (P.M.B.) or Official Records (O.R.) in the office of the County Recorder of said county as shown on Exhibit "B" attached hereto and by reference made a part hereof:

FACILITY/ PARCEL NO.	TR./PM. NO.	M.M./P.M.B. O.R NO.	RECORDING DATE	LOT(S)	PURPOSE
GA 1014-3 (a)		O.R. 9556/676	2/26/1971		Street, Highway & Public Parking
GA 1014-3 (b)		O.R. 9556/676	2/26/1971		Street, Highway & Public Parking
GA 1014-3 (c)	Tr. 21	M.M. 9/22		Block 216	Public Use

Those certain interests dedicated to THE ORANGE COUNTY HARBOR DISTRICT (currently held by the County of Orange, its successor in interest) for public thoroughfare and public use in the Unincorporated Territory of the County of Orange, State of California per the following documents recorded in Miscellaneous Maps (M.M.), Parcel Map Book (P.M.B.) or Official Records (O.R.) in the office of the County Recorder of said county as shown on Exhibit "B" attached hereto and by reference made a part hereof:

FACILITY/ PARCEL NO.	TR./PM. NO.	M.M./P.M.B. O.R NO.	RECORDING DATE	LOT(S)	PURPOSE
GA 1014-1		O.R. 7618/767	8/4/1965		Public Thoroughfare
GA 1014-2		O.R. 7618/767	8/4/1965		Public Use

APPROVED

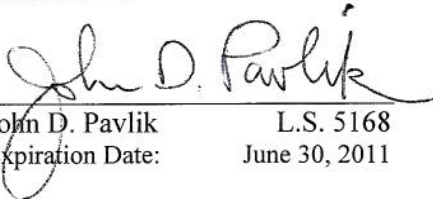

John D. Pavlik L.S. 5168
Expiration Date: June 30, 2011

Date: 11/5/10

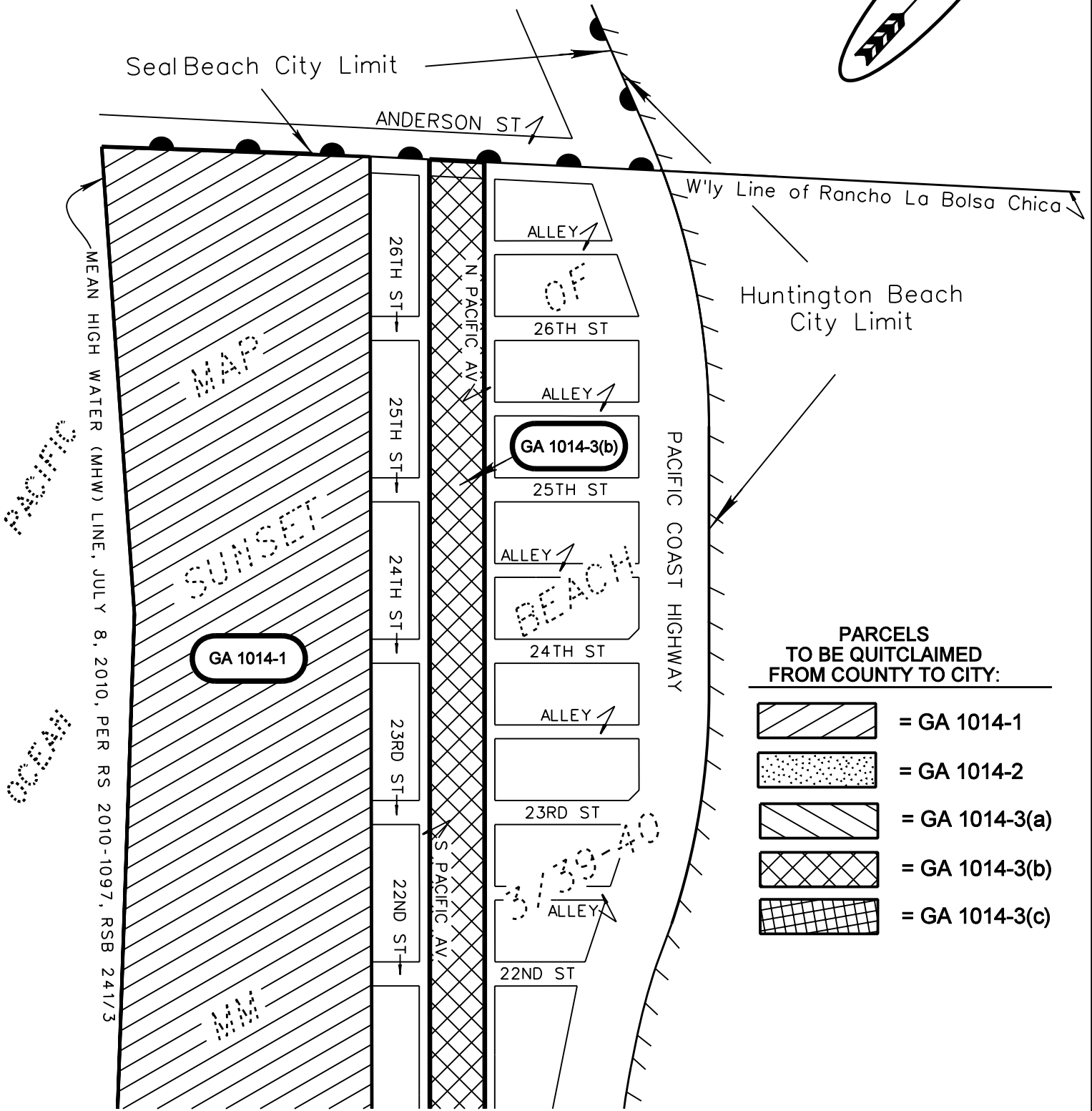
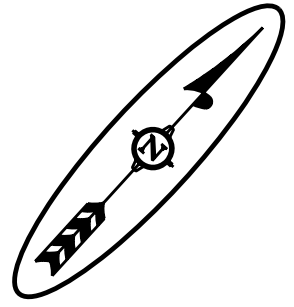

EXHIBIT B

Attachment B



PARCELS TO BE QUITCLAIMED FROM COUNTY TO CITY:

	= GA 1014-1
	= GA 1014-2
	= GA 1014-3(a)
	= GA 1014-3(b)
	= GA 1014-3(c)

SEE PAGE 2





**ORANGE COUNTY OC PUBLIC WORKS - RIGHT OF WAY ENGINEERING
RIGHT OF WAY MAP - COMPILED FROM PUBLIC RECORDS**

QUITCLAIM OF RIGHTS FROM COUNTY OF ORANGE TO THE CITY OF HUNTINGTON BEACH

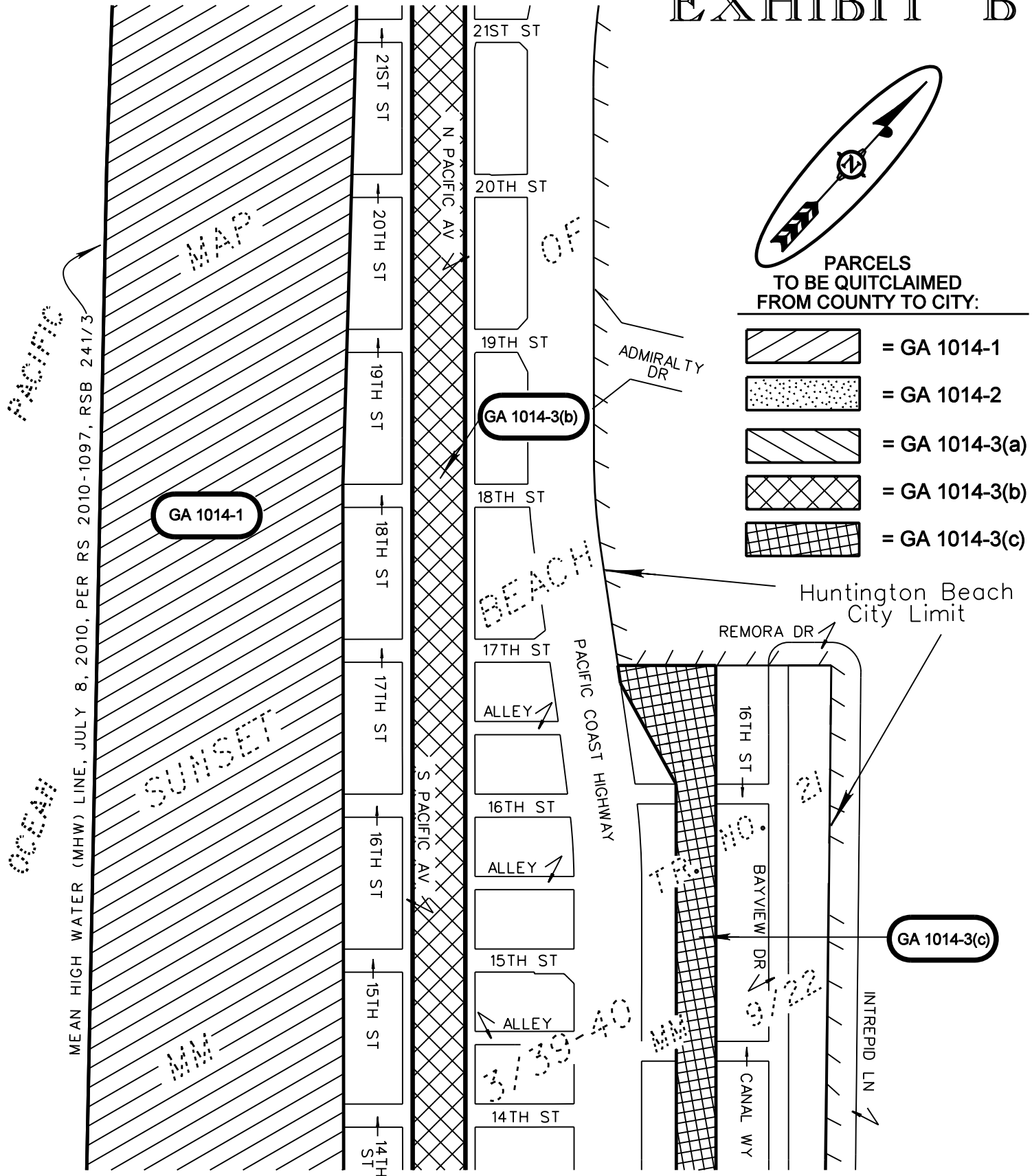
EXHIBIT B

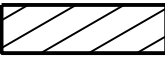
SEE PAGE 1



- PARCELS TO BE QUITCLAIMED FROM COUNTY TO CITY:**
-  = GA 1014-1
 -  = GA 1014-2
 -  = GA 1014-3(a)
 -  = GA 1014-3(b)
 -  = GA 1014-3(c)

SEE PAGE 3

ORANGE COUNTY OC PUBLIC WORKS - RIGHT OF WAY ENGINEERING
 RIGHT OF WAY MAP - COMPILED FROM PUBLIC RECORDS

QUITCLAIM OF RIGHTS FROM COUNTY OF ORANGE TO THE CITY OF HUNTINGTON BEACH

SEE PAGE 2

Attachment B

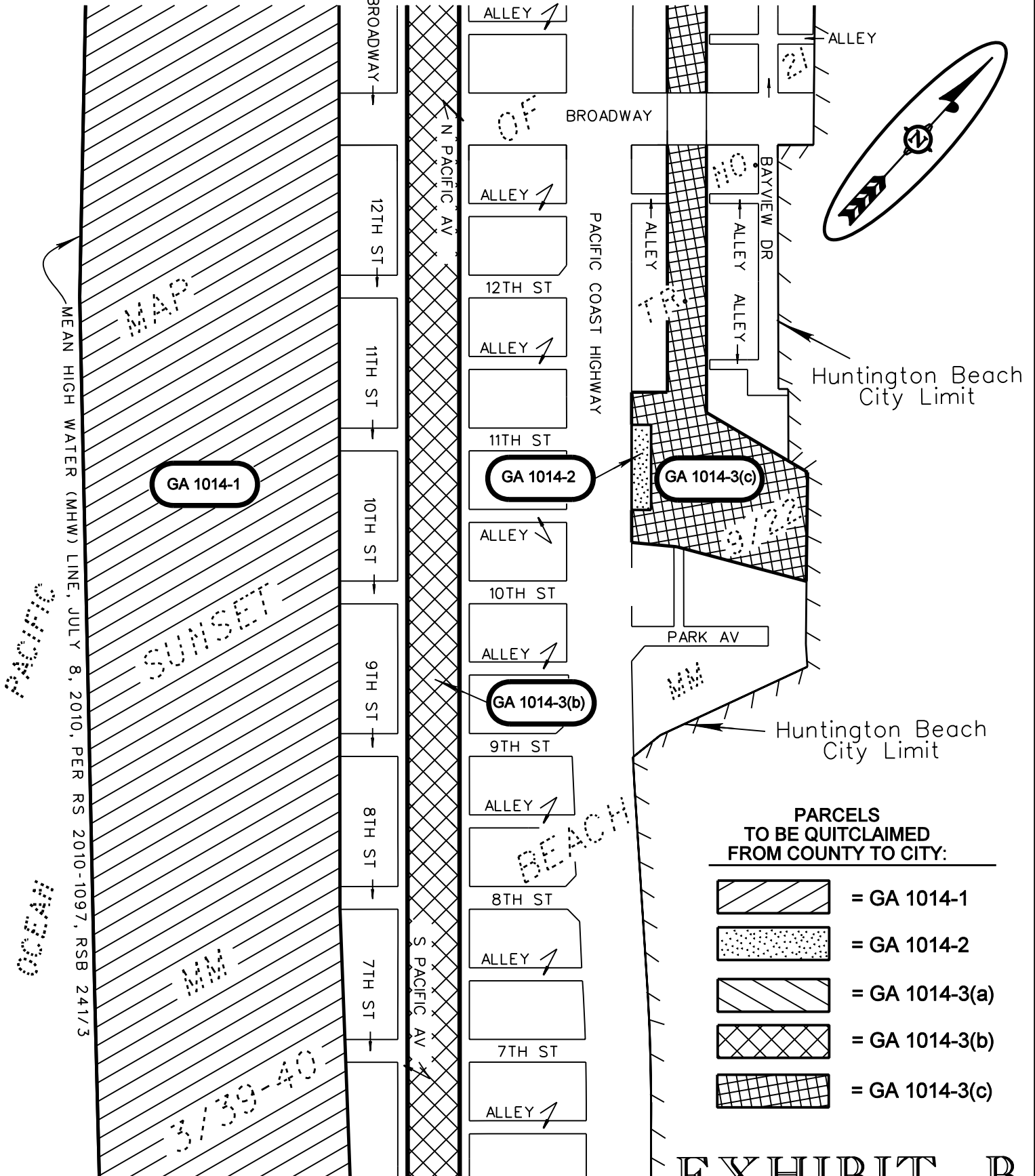

PARCELS TO BE QUITCLAIMED FROM COUNTY TO CITY:





-  = GA 1014-1
-  = GA 1014-2
-  = GA 1014-3(a)
-  = GA 1014-3(b)
-  = GA 1014-3(c)

EXHIBIT B

SEE PAGE 4

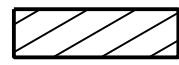
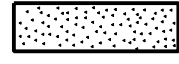
ORANGE COUNTY OC PUBLIC WORKS - RIGHT OF WAY ENGINEERING RIGHT OF WAY MAP - COMPILED FROM PUBLIC RECORDS

QUITCLAIM OF RIGHTS FROM COUNTY OF ORANGE TO THE CITY OF HUNTINGTON BEACH

PREP. BY: ARA

CHKD. BY: JDP

DATE: 11/09/10

SCALE : 1" = 200'



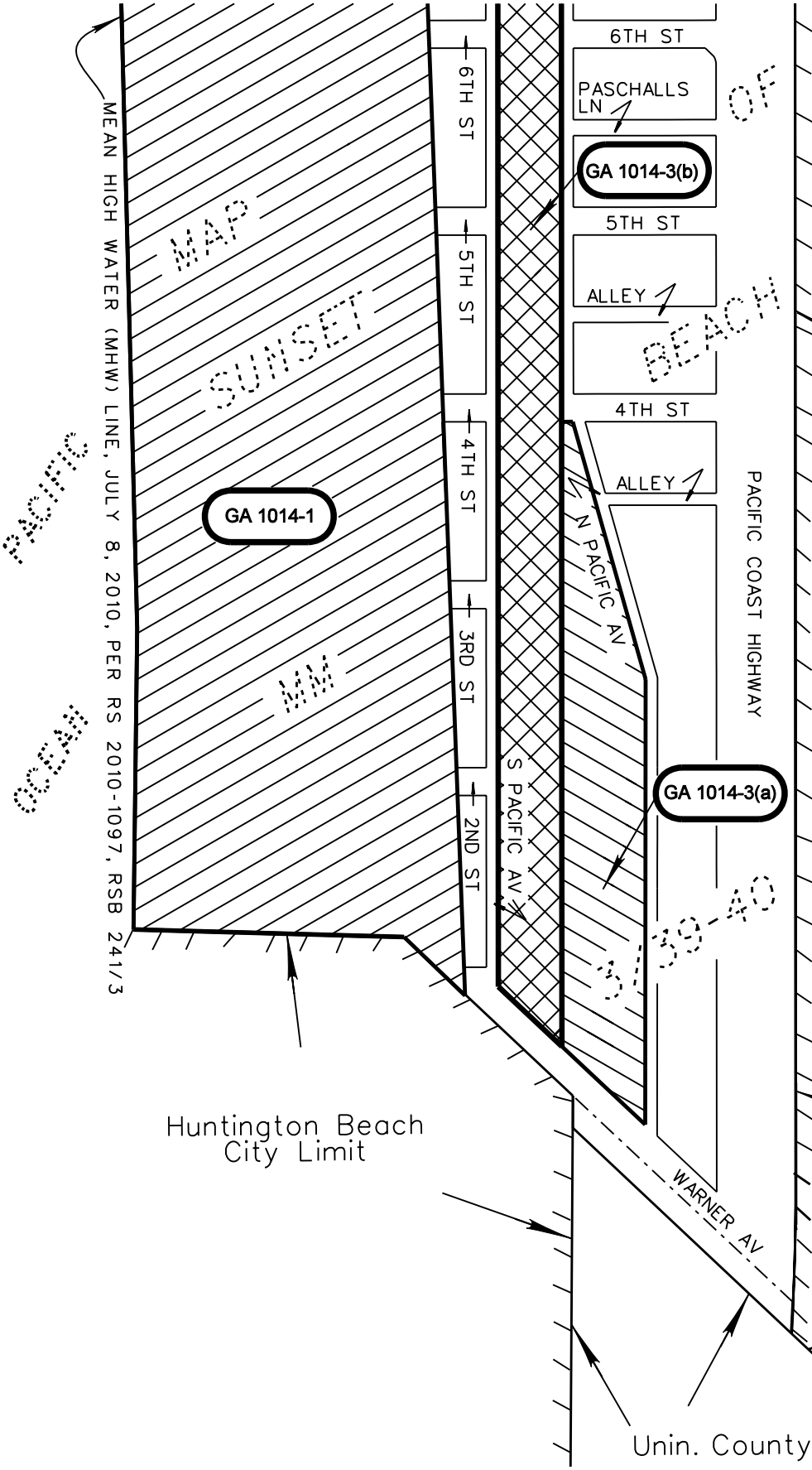

Page 37 of 54
PAGE 3 OF 4

EXHIBIT B

SEE PAGE 3



PARCELS TO BE QUITCLAIMED FROM COUNTY TO CITY:

-  = GA 1014-1
-  = GA 1014-2
-  = GA 1014-3(a)
-  = GA 1014-3(b)
-  = GA 1014-3(c)

ORANGE COUNTY OC PUBLIC WORKS - RIGHT OF WAY ENGINEERING RIGHT OF WAY MAP - COMPILED FROM PUBLIC RECORDS

QUITCLAIM OF RIGHTS FROM COUNTY OF ORANGE TO THE CITY OF HUNTINGTON BEACH

Exhibit F
(Facilities to Transfer)

Facilities Transfer - Streets/Roads

ROAD NAME:	LIMITS:	ROAD MILES	LANES:	LANE MILES:
ALLEY - 1ST STREET S/WARNER AVE.	SIMS TO LYNN ST.	0.12	2	0.24
ALLEY - BTWN 16TH & 17TH STREETS	8' NE/ TO 106' NE/O NORTH PACIFIC AVE.	0.02	2	0.04
ALLEY - BTWN 24TH & 25TH STREETS	8' NE/ TO 210' NE/O NORTH PACIFIC AVE.	0.04	2	0.08
ALLEY - BTWN 4TH & 5TH STREETS	8' NE/ TO 180' NE/O NORTH PACIFIC AVE.	0.03	2	0.06
ALLEY - BTWN 6TH & 7TH STREETS	8' NE/ TO 173' NE/O NORTH PACIFIC AVE.	0.03	2	0.06
ALLEY - BTWN 7TH & 8TH STREETS	NORTH PACIFIC AVE. TO 0.02 N/	0.02	2	0.04
ALLEY - 1ST STREET W/BROADWAY	LAGOON TO 0.01 MI N/BAY VIEW DRIVE	0.02	2	0.04
ALLEY - 1ST E/BROADWAY	PACIFIC COAST HWY. TO 0.01 NE/	0.01	2	0.02
ALLEY - 1ST E/BROADWAY	0.01 NE/PACIFIC COAST HWY. TO BAYVIEW DR.	0.01	2	0.02
ALLEY - 1ST STREET W/13TH STREET	50' W/O PACIFIC COAST HWY. TO NORTH PACIFIC ST.	0.01	2	0.02
ALLEY - 1ST STREET W/12TH STREET	PACIFIC COAST HWY. TO NORTH PACIFIC STREET	0.03	2	0.06
ALLEY - BTWN 10TH & 11TH STREETS	8' NE/ TO 150' NE/O NORTH PACIFIC AVE.	0.03	2	0.06
ALLEY - BTWN 11TH & 12TH STREETS	NORTH PACIFIC AVE. TO 0.02N/	0.02	2	0.04
ALLEY - BTWN 12TH & BROADWAY	8' NE/ TO 150' NE/O NORTH PACIFIC AVE.	0.03	2	0.06
ALLEY - BTWN 14TH & 15TH STREETS	8' NE/ TO 158' NE/O NORTH PACIFIC AVE.	0.03	2	0.06
ALLEY - BTWN 15TH & 16TH STREETS	8' NE/ TO 158' NE/O NORTH PACIFIC AVE.	0.03	2	0.06
ALLEY - BTWN 22ND & 23RD STREETS	8' NE/ TO 165' NE/O NORTH PACIFIC AVE.	0.03	2	0.06
ALLEY - BTWN 23RD & 24TH STREETS	8' NE/ TO 211' NE/O NORTH PACIFIC AVE.	0.04	2	0.08
ALLEY - BTWN 25TH & 26TH STREETS	NORTH PACIFIC AVE TO 0.02 N/	0.02	2	0.04
ALLEY - BTWN 3RD & 4TH STREETS	8' NE/ TO 138' NE/O NORTH PACIFIC AVE.	0.02	2	0.04
ALLEY - BTWN 8TH & 9TH STREETS	8' NE/ TO 159' NE/O NORTH PACIFIC AVE.	0.03	2	0.06
ALLEY - BTWN 9TH & 10TH STREETS	8' NE/ TO 150' NE/O NORTH PACIFIC AVE.	0.03	2	0.06
ALLEY - BTWN BROADWAY & 14TH STREETS	8' NE/ TO 150' NE/O NORTH PACIFIC AVE.	0.03	2	0.06
ALLEY - N/COAST HIGHWAY	0.02 W/TO 0.02 E/PARK AVE.	0.04	2	0.08
ALLEY-BTWN 26TH STREET&ANDERSON	NORTH PACIFIC AVE. TO 0.02 N/ PACIFIC COAST HWY.	0.02	2	0.04
ANDERSON STREET	SOUTH PACIFIC AVE. SOUTHERLY TO END	0.02	2	0.04
ANDERSON STREET	SOUTH PACIFIC AVE. TO 0.05 N/O NORTH PACIFIC AVE.	0.05	2	0.1
BAYVIEW DRIVE	0.18 W/ TO 0.07 E/ BROADWAY	0.25	2	0.5
BROADWAY	SOUTH PACIFIC AVE. TO 0.02 S/	0.02	2	0.04
BROADWAY	SOUTH PACIFIC AVE. TO 0.05 N/	0.05	2	0.1
BROADWAY	PACIFIC COAST HWY. TO BAYVIEW DR.	0.04	2	0.08
BROADWAY	BAYVIEW DR. TO 0.01 N/	0.01	2	0.02
CANAL WAY	72' N/O PACIFIC COAST HWY. TO 208' N/	0.04	2	0.08
EIGHTEENTH STREET	8' NE/ TO 82' NE/O NORTH PACIFIC AVE.	0.02	2	0.04
EIGHTEENTH STREET	SOUTH PACIFIC AVE. TO 0.01 S/	0.01	2	0.02
EIGHTH STREET	SOUTH PACIFIC AVE. TO 0.02 S/	0.02	2	0.04
EIGHTH STREET	8' NE/ TO 166' NE/O NORTH PACIFIC AVE.	0.03	2	0.06
ELEVENTH STREET	SOUTH PACIFIC AVE. TO 0.02 S/	0.02	2	0.04
ELEVENTH STREET	8' NE/ TO 150' NE/O NORTH PACIFIC AVE.	0.03	2	0.06
FIFTEENTH STREET	SOUTH PACIFIC AVE. TO 0.02 S/	0.02	2	0.04
FIFTEENTH STREET	8' NE/ TO 158' NE/O NORTH PACIFIC AVE.	0.03	2	0.06
FIFTH STREET	PACIFIC OCEAN TO SOUTH PACIFIC AVE.	0.02	2	0.04
FIFTH STREET	NORTH PACIFIC AVE. TO 0.05 N/	0.05	2	0.1
FOURTEENTH STREET	SOUTH PACIFIC AVE. TO END	0.02	2	0.04
FOURTEENTH STREET	8' NE/ TO 150' NE/O NORTH PACIFIC AVE.	0.03	2	0.06
FOURTH STREET	SOUTH PACIFIC AVE. TO END	0.01	2	0.02
FOURTH STREET	8' NE/ TO 172' NE/O NORTH PACIFIC AVE.	0.03	2	0.06
NINETEENTH STREET	SOUTH PACIFIC AVE. TO 0.01 S/	0.01	2	0.02
NINETEENTH STREET	8' NE/ TO 85' NE/O NORTH PACIFIC AVE.	0.02	2	0.04
NINTH STREET	8' NE/ TO 225' NE/O NORTH PACIFIC AVE.	0.04	2	0.08
NINTH STREET	SOUTH PACIFIC AVE. TO 0.02 S/	0.02	2	0.04
NORTH PACIFIC AVENUE	WARNER AVE. TO ANDERSON ST.	1.19	2	2.38
PARK AVENUE	PACIFIC COAST HWY. TO 0.06 NE/	0.06	2	0.12
PASCHALLS LANE	8' NE/ TO 180' NE/O NORTH PACIFIC AVE.	0.03	2	0.06
SECOND STREET	SOUTH PACIFIC AVE. TO END	0.01	2	0.02
SEVENTEENTH STREET	8' NE/ TO 120' NE/O NORTH PACIFIC AVE.	0.02	2	0.04
SEVENTEENTH STREET	SOUTH PACIFIC AVE. TO 0.02 S/	0.02	2	0.04
SEVENTH STREET	8' NE/ TO 179' NE/O NORTH PACIFIC AVE.	0.03	2	0.06
SEVENTH STREET	SOUTH PACIFIC AVE. TO 0.02 S/	0.02	2	0.04
SIXTEENTH STREET	0.01 SW/ TO BAYVIEW DR.	0.01	2	0.02
SIXTEENTH STREET	8' NE/ TO 158' NE/O NORTH PACIFIC AVE.	0.03	2	0.06
SIXTEENTH STREET	72' N/O PACIFIC COAST HWY. TO 66' N/	0.0125	2	0.025
SIXTEENTH STREET	SOUTH PACIFIC AVE. TO 0.02 S/	0.02	2	0.04

Facilities Transfer - Streets/Roads

ROAD NAME:	LIMITS:	ROAD MILES	LANES:	LANE MILES:
SIXTH STREET	8' NE/ TO 190' NE/O NORTH PACIFIC AVE.	0.04	2	0.08
SIXTH STREET	SOUTH PACIFIC AVE. TO 0.02 S/	0.02	2	0.04
SOUTH PACIFIC AVENUE	WARNER AVE. TO ANDERSON ST.	1.19	2	2.38
TENTH STREET	SOUTH PACIFIC AVE. TO 0.02 S/	0.02	2	0.04
TENTH STREET	8' NE/ TO 150' NE/O NORTH PACIFIC AVE.	0.03	2	0.06
THIRD STREET	SOUTH PACIFIC AVE. TO END	0.01	2	0.02
TWELFTH STREET	8' NE/ TO 163' NE/O NORTH PACIFIC AVE.	0.03	2	0.06
TWELFTH STREET	SOUTH PACIFIC AVE. TO 0.02 S/	0.02	2	0.04
TWENTIETH STREET	8' NE/ TO 144' NE/O NORTH PACIFIC AVE.	0.02	2	0.04
TWENTIETH STREET	0.01 SW/ TO SOUTH PACIFIC AVE.	0.01	2	0.02
TWENTY-FIFTH STREET	SOUTH PACIFIC AVE. TO 0.02 S/	0.02	2	0.04
TWENTY-FIFTH STREET	8' NE/ TO 210' NE/O NORTH PACIFIC AVE.	0.04	2	0.08
TWENTY-FIRST STREET	0.01 SW/ TO SOUTH PACIFIC AVE.	0.01	2	0.02
TWENTY-FIRST STREET	8' NE/ TO 53' NE/O NORTH PACIFIC AVE.	0.02	2	0.04
TWENTY-FOURTH STREET	8' NE/ TO 224' NE/O NORTH PACIFIC AVE.	0.04	2	0.08
TWENTY-FOURTH STREET	SOUTH PACIFIC AVE. TO 0.02 S/	0.02	2	0.04
TWENTY-SECOND STREET	SOUTH PACIFIC AVE. TO 0.02 S/	0.02	2	0.04
TWENTY-SECOND STREET	NORTH PACIFIC AVE. TO 0.03 N/	0.03	2	0.06
TWENTY-SIXTH STREET	SOUTH PACIFIC AVE. TO 0.01 S/	0.01	2	0.02
TWENTY-SIXTH STREET	8' NE/ TO 211' NE/O NORTH PACIFIC AVE.	0.04	2	0.08
TWENTY-THIRD STREET	SOUTH PACIFIC AVE. TO 0.01 S/	0.01	2	0.02
TWENTY-THIRD STREET	8' NE/ TO 191' NE/O NORTH PACIFIC AVE.	0.04	2	0.08
WARNER AVENUE	0.01 S/O NORTH PACIFIC AVE. TO 0.03 N/	0.03	2	0.06
WARNER AVENUE (W1/2)	0.04 S/ TO 0.01 S/ NORTH PACIFIC AVE.	0.03	1	0.03

Total 4.8525 9.675

Facilities Transfer - Signs

SIGN CODE	LOC. REF.	STREET NAME	STREET_SUFFIX	LOC. REF.	CROSS STREET	Combo113	DATE INSTALLED	SIZE	MUTCD	SUFFIX
R1	WS	ALLEY - BTWN 23RD & 24TH	ALLEY	NO	NORTH PACIFIC	AVE	3/6/1985	24x24	R1-1	
R1	WS	ALLEY - BTWN 24TH & 25TH	ALLEY	NO	NORTH PACIFIC	AVE	3/6/1985	24x24	R1-1	
NR26PT	WS	ALLEY- BTWN 25TH & 26TH ST	ALLEY	NO	NORTH PACIFIC	AVE		12x18	-	
R1	WS	ALLEY- BTWN 25TH & 26TH ST	ALLEY	NO	NORTH PACIFIC	AVE		30x30	R1-1	
NR26PT	ES	ALLEY-BTWN 25TH & 26TH ST	ALLEY	NO	NORTH PACIFIC	AVE		12x18	-	
R28	ES	ALLEY-BTWN 25TH & 26TH ST	ALLEY	NO	NORTH PACIFIC	AVE		12x18	-	L
R1	WS	ALLEY- BTWN 3RD & 4TH ST	ALLEY	NO	NORTH PACIFIC	AVE	3/6/1985	30x30	R1-1	
R1	WS	ALLEY-BTWN 14TH & 15TH ST	ALLEY	NO	NORTH PACIFIC	AVE	3/6/1985	30x30	R1-1	
R1	WS	ALLEY-BTWN 15TH & 16TH ST	ALLEY	NO	NORTH PACIFIC	AVE	3/6/1985	30x30	R1-1	
R1	WS	ALLEY-BTWN 16TH & 17TH ST	ALLEY	NO	NORTH PACIFIC	AVE	6/18/1968	30x30	R1-1	
R28	WS	ALLEY NO 17	ALLEY	NO	NORTH PACIFIC	AVE	6/18/1968	12x18	-	L
R1	WS	ALLEY-BTWN 26TH & ANDERSON	ALLEY	NO	NORTH PACIFIC	AVE	6/18/1968	30x30	R1-1	
R28	WS	ALLEY-BTWN 26TH & ANDERSON	ALLEY	NO	NORTH PACIFIC	AVE	6/18/1968	12x18	-	R
R1	WS	PASCHALLS	LN	NO	NORTH PACIFIC	AVE	1/29/1985	30x30	R1-1	
R26	WS	PASCHALLS	LN	NO	NORTH PACIFIC	AVE	3/6/1985	12x18	-	
R1	WS	ALLEY - BTWN 6TH & 7TH ST	ALLEY	NO	NORTH PACIFIC	AVE	3/6/1985	30x30	R1-1	
R1	WS	ALLEY-BTWN 7TH & 8TH ST	ALLEY	NO	NORTH PACIFIC	AVE	3/6/1985	30x30	R1-1	
R1	WS	ALLEY-BTWN 9TH & 10TH ST	ALLEY	NO	NORTH PACIFIC	AVE	3/6/1985	30x30	R1-1	
R1	WS	ALLEY-BTWN 8TH & 9TH ST	ALLEY	NO	NORTH PACIFIC	AVE	3/6/1985	24x24	R1-1	
R1	WS	ALLEY-BTWN 10TH & 11TH ST	ALLEY	NO	NORTH PACIFIC	AVE	3/6/1985	30x30	R1-1	
R1	WS	ALLEY-BTWN 11TH & 12TH ST	ALLEY	NO	NORTH PACIFIC	AVE	3/6/1985	30x30	R1-1	
R1	WS	ALLEY-BTWN 14TH & BROADWAY	ALLEY	NO	NORTH PACIFIC	AVE	9/23/1968	24x24	R1-1	
NR39	SS	BAYVIEW	DR	EO	BROADWAY	-		18x24	-	
R26	SS	BAYVIEW	DR	EO	ALLEY @ 16875	ALLEY		12x18	-	
R1	SS	BAYVIEW	DR	WO	BROADWAY	-		24x24	R1-1	
NR39	SS	BAYVIEW	DR	EO	BROADWAY	-		18x24	-	
NR39	ES	CANAL	WY	SO	BAYVIEW	AVE		18x24	-	
R26T	MO	EIGHTEENTH	ST	SO	SOUTH PACIFIC	AVE	8/25/1994	18x24	-	LR
R1	WS	EIGHTEENTH	ST	NO	NORTH PACIFIC	AVE	2/1/1985	30x30	R1-1	
R26T	MO	EIGHTH	ST	SO	SOUTH PACIFIC	AVE	8/25/1994	18x24	-	LR
R1	WS	EIGHTH	ST	NO	NORTH PACIFIC	AVE	2/1/1985	30x30	R1-1	
R26T	MO	ELEVENTH	ST	SO	SOUTH PACIFIC	AVE	8/25/1994	18x24	-	LR
R1	WS	ELEVENTH	ST	NO	NORTH PACIFIC	AVE	5/14/1980	30x30	R1-1	
R1	WS	FIFTEENTH	ST	NO	NORTH PACIFIC	AVE	2/1/1985	30x30	R1-1	

Facilities Transfer - Signs

SIGN CODE	LOC. REF.	STREET NAME	STREET_SUFFIX	LOC. REF.	CROSS STREET	Combo113	DATE INSTALLED	SIZE	MUTCD	SUFFIX
R1	WS	FIFTH	ST	NO	SOUTH PACIFIC	AVE	1/29/1985	30x30	R1-1	
R10A	ES	FIFTH	ST	NO	SOUTH PACIFIC	AVE	2/1/1985	24x18	R6-2	
R1	WS	FOURTEENTH	ST	NO	NORTH PACIFIC	AVE	2/1/1985	30x30	R1-1	
R1	WS	FOURTH	ST	NO	NORTH PACIFIC	AVE	1/20/1969	30x30	R1-1	
R1	NS	NORTH PACIFIC	AVE	EO	ANDERSON	ST	1/29/1985	30x30	R1-1	
NR26PT	NS	NORTH PACIFIC	AVE	EO	ANDERSON	ST	1/29/1985	12x18	-	
R10A	SS	NORTH PACIFIC	AVE	EO	ANDERSON	ST	2/25/1985	24x18	R6-2	
G93	NS	NORTH PACIFIC	AVE	EO	ANDERSON	ST	1/29/1985	24x18	D11-1	
R2	SS	NORTH PACIFIC	AVE	WO	BROADWAY	-	1/29/1985	24x30	R2-1	15
R1	NS	NORTH PACIFIC	AVE	EO	BROADWAY	-	1/29/1985	30x30	R1-1	
NR26PT	NS	NORTH PACIFIC	AVE	WO	BROADWAY	-	10/30/1973	12x18	-	T
G93	NS	NORTH PACIFIC	AVE	EO	BROADWAY	-		24x18	D11-1	
R10A	SS	NORTH PACIFIC	AVE	EO	BROADWAY	-	10/30/1973	24x18	R6-2	
NR26PT	NS	NORTH PACIFIC	AVE	EO	FIFTH	ST	1/29/1985	12x18	-	
NR26PT	SS	NORTH PACIFIC	AVE	EO	FIFTH	ST	1/29/1985	12x18	-	
NR26PT	NS	NORTH PACIFIC	AVE	WO	EIGHTEENTH	ST	1/29/1985	12x18	-	
NR26PT	NS	NORTH PACIFIC	AVE	WO	EIGHTEENTH	ST		12x18	-	
R10A	SS	NORTH PACIFIC	AVE	AT	EIGHTEENTH	ST	10/30/1973	18x24	R6-2	
NR26PT	NS	NORTH PACIFIC	AVE	WO	EIGHTH	ST	1/29/1985	12x18	-	
NR26PT	SS	NORTH PACIFIC	AVE	WO	EIGHTH	ST	1/29/1985	12x18	-	
NR26PT	NS	NORTH PACIFIC	AVE	EO	EIGHTH	ST	1/29/1985	12x18	-	
R10A	SS	NORTH PACIFIC	AVE	EO	EIGHTH	ST		24x18	R6-2	
NR26PT	NS	NORTH PACIFIC	AVE	EO	ELEVENTH	ST		12x18	-	
R10A	SS	NORTH PACIFIC	AVE	AT	ELEVENTH	ST	1/29/1985	24x18	R6-2	
R10A	SS	NORTH PACIFIC	AVE	AT	FIFTEENTH	ST	1/29/1985	24x18	R6-2	R
NR26PT	NS	NORTH PACIFIC	AVE	WO	FIFTEENTH	ST	1/29/1985	12x18	-	
NR26PT	NS	NORTH PACIFIC	AVE	EO	FIFTEENTH	ST	1/29/1985	12x18	-	
G93	NS	NORTH PACIFIC	AVE	EO	FIFTEENTH	ST	12/12/1996	18x24	D11-1	
NR26PT	NS	NORTH PACIFIC	AVE	EO	FIFTH	ST		12x18	-	
NR26PT	NS	NORTH PACIFIC	AVE	EO	FIFTH	ST		12x18	-	
NR26PT	NS	NORTH PACIFIC	AVE	WO	FIFTH	ST	1/29/1985	12x18	-	
G93	NS	NORTH PACIFIC	AVE	WO	SIXTH	ST		18x24	D11-1	
R10A	MO	NORTH PACIFIC	AVE	AT	FOURTEENTH	ST	3/5/1980	24x18	R6-2	
NR26PT	NS	NORTH PACIFIC	AVE	WO	FOURTEENTH	ST	1/29/1985	12x18	-	

Facilities Transfer - Signs

SIGN CODE	LOC. REF.	STREET NAME	STREET_SUFFIX	LOC. REF.	CROSS STREET	Combo113	DATE INSTALLED	SIZE	MUTCD	SUFFIX
NR26PT	NS	NORTH PACIFIC	AVE	WO	FOURTEENTH	ST	6/3/1980	12x18	-	
R2	SS	NORTH PACIFIC	AVE	AT	FOURTH	ST	1/29/1985	24x30	R2-1	15
NR26PT	NS	NORTH PACIFIC	AVE	WO	FOURTH	ST	10/30/1973	12x18	-	
NR26PT	NS	NORTH PACIFIC	AVE	WO	FOURTH	ST	10/30/1973	12x18	-	
NR26PT	NS	NORTH PACIFIC	AVE	EO	FOURTH	ST	1/29/1985	12x18	-	
R10A	SS	NORTH PACIFIC	AVE	AT	FOURTH	ST	1/29/1985	24x18	R6-2	
NR26PT	SS	NORTH PACIFIC	AVE	AT	FOURTH	ST	1/29/1985	12x18	-	
NR26PT	NS	NORTH PACIFIC	AVE	WO	NINETEENTH	ST	1/29/1985	12x18	-	
NR26PT	NS	NORTH PACIFIC	AVE	WO	NINETEENTH	ST	12/12/1996	12x18	-	
R2	SS	NORTH PACIFIC	AVE	WO	NINETEENTH	ST	12/12/1996	24x30	R2-1	15
NR26PT	NS	NORTH PACIFIC	AVE	EO	NINETEENTH	ST	1/29/1985	12x18	-	
R1	NS	NORTH PACIFIC	AVE	EO	NINETEENTH	ST	3/5/1980	30x30	R1-1	
G93	NS	NORTH PACIFIC	AVE	EO	NINETEENTH	ST		18x24	D11-1	
R10A	SS	NORTH PACIFIC	AVE	AT	NINTH	ST	10/30/1973	18x24	R6-2	
NR26PT	SS	NORTH PACIFIC	AVE	WO	NINTH	ST	12/12/1996	12x18	-	
NR26PT	NS	NORTH PACIFIC	AVE	EO	PASCHALLS	LN	1/29/1985	12x18	-	
G93	NS	NORTH PACIFIC	AVE	WO	SECOND	ST	1/29/1985	24x18	D11-1	
TYPE N	NS	NORTH PACIFIC	AVE	EO	SECOND	ST	1/29/1985	18x18	OM1-3	2
R2	NS	NORTH PACIFIC	AVE	EO	SECOND	ST	2/25/1985	24x30	R2-1	15
NR26PT	NS	NORTH PACIFIC	AVE	WO	SECOND	ST	1/29/1985	12x18	-	
W56	NS	NORTH PACIFIC	AVE	AT	SECOND	ST	10/30/1973	36x18	W1-7	
NR26PT	MO	NORTH PACIFIC	AVE	WO	SECOND	ST	1/29/1985	12x18	-	
NR26PT	NS	NORTH PACIFIC	AVE	WO	SECOND	ST	1/29/1985	12x18	-	
NR26PT	MO	NORTH PACIFIC	AVE	EO	SECOND	ST	1/29/1985	12x18	-	
R10A	SS	NORTH PACIFIC	AVE	WO	SEVENTEENTH	ST	2/1/1985	24x18	R6-2	
R10A	NS	NORTH PACIFIC	AVE	WO	SEVENTH	ST	1/29/1985	24x18	R6-2	
NR26PT	NS	NORTH PACIFIC	AVE	WO	SEVENTH	ST	1/29/1985	12x18	-	
R2	SS	NORTH PACIFIC	AVE	WO	SEVENTH	ST	1/29/1985	24x30	R2-1	15
NR26PT	WS	SIXTEENTH	ST	NO	NORTH PACIFIC	AVE	1/29/1985	12x18	-	
NR26PT	NS	NORTH PACIFIC	AVE	EO	SIXTEENTH	ST	1/29/1985	12x18	-	
R10A	NS	NORTH PACIFIC	AVE	EO	SIXTEENTH	ST	2/1/1985	18x24	R6-2	
R10A	SS	NORTH PACIFIC	AVE	AT	SIXTH	AVE	1/29/1985	24x18	R6-2	
NR26PT	NS	NORTH PACIFIC	AVE	WO	SIXTH	ST	1/29/1985	12x18	-	
NR26PT	NS	NORTH PACIFIC	AVE	EO	SIXTH	ST	1/29/1985	12x18	-	

Facilities Transfer - Signs

SIGN CODE	LOC. REF.	STREET NAME	STREET_SUFFIX	LOC. REF.	CROSS STREET	Combo113	DATE INSTALLED	SIZE	MUTCD	SUFFIX
NR26PT	NS	NORTH PACIFIC	AVE	EO	SIXTH	ST		12x18	-	
NR26PT	NS	NORTH PACIFIC	AVE	WO	TENTH	ST	1/29/1985	12x18	-	
NR26PT	NS	NORTH PACIFIC	AVE	WO	TENTH	ST	1/29/1985	12x18	-	
NR26PT	NS	NORTH PACIFIC	AVE	WO	TENTH	ST	1/29/1985	12x18	-	
NR26PT	NS	NORTH PACIFIC	AVE	EO	TENTH	ST	10/30/1973	12x18	-	
G93	NS	NORTH PACIFIC	AVE	EO	TWELFTH	ST	12/12/1996	18x24	D11-1	
NR26PT	NS	NORTH PACIFIC	AVE	EO	TWELFTH	ST		12x18	-	
NR26PT	NS	NORTH PACIFIC	AVE	WO	TWELFTH	ST	1/29/1985	12x18	-	
NR26PT	NS	NORTH PACIFIC	AVE	WO	TWELFTH	ST		12x18	-	
R10A	SS	NORTH PACIFIC	AVE	AT	TWELFTH	ST	1/29/1985	18x24	R6-2	
NR26PT	NS	NORTH PACIFIC	AVE	EO	TWENTIETH	ST		12x18	-	
NR26PT	NS	NORTH PACIFIC	AVE	WO	TWENTY FIFTH	ST	1/29/1985	12x18	-	
NR26PT	NS	NORTH PACIFIC	AVE	WO	TWENTY FIRST	ST	10/30/1973	12x18	-	
G93	NS	NORTH PACIFIC	AVE	WO	TWENTY FIRST	ST	12/12/1996	18x24	D11-1	
NR26PT	NS	NORTH PACIFIC	AVE	EO	TWENTY FIRST	ST	1/29/1985	12x18	-	
R10A	SS	NORTH PACIFIC	AVE	AT	TWENTY FIRST	ST	6/1/1988	18x24	R6-2	R
NR26PT	NS	NORTH PACIFIC	AVE	WO	TWENTY FOURTH	ST	1/29/1985	12x18	-	
R10A	SS	NORTH PACIFIC	AVE	AT	TWENTY FOURTH	ST	1/29/1985	24x18	R6-2	
NR26PT	NS	NORTH PACIFIC	AVE	WO	TWENTY SECOND	ST	1/29/1985	12x18	-	
NR26PT	NS	NORTH PACIFIC	AVE	EO	TWENTY SECOND	ST	1/29/1985	12x18	-	
R2	SS	NORTH PACIFIC	AVE	WO	TWENTY SECOND	ST	1/29/1985	24x30	R2-1	15
NR26PT	NS	NORTH PACIFIC	AVE	EO	TWENTY SIXTH	ST	1/29/1985	12x18	-	
R10A	SS	NORTH PACIFIC	AVE	AT	TWENTY SIXTH	ST	1/29/1985	18x24	R6-2	
NR26PT	NS	NORTH PACIFIC	AVE	WO	TWENTY THIRD	ST	1/29/1985	12x18	-	
G93	NS	NORTH PACIFIC	AVE	WO	TWENTY THIRD	ST		18x24	D11-1	
NR26PT	NS	NORTH PACIFIC	AVE	EO	TWENTY THIRD	ST	1/29/1985	12x18	-	
R10A	SS	NORTH PACIFIC	AVE	EO	TWENTY THIRD	ST	10/30/1973	18x24	R6-2	
TYPE N	MO	NORTH PACIFIC	AVE	WO	WARNER	AVE	1/29/1985	18x18	OM1-3	
R1	MO	NORTH PACIFIC	AVE	WO	WARNER	AVE	1/29/1985	30x30	R1-1	
NR26PT	NS	NORTH PACIFIC	AVE	WO	WARNER	AVE	3/5/1980	12x18	-	
NR26PT	NS	NORTH PACIFIC	AVE	WO	WARNER	AVE	1/29/1985	12x18	-	
NR26PT	NS	NORTH PACIFIC	AVE	WO	WARNER	AVE	1/29/1985	12x18	-	
R1	SS	NORTH PACIFIC	AVE	WO	WARNER	AVE	10/30/1973	30x30	R1-1	
R26T	MO	NINETEENTH	ST	SO	SOUTH PACIFIC	AVE	8/25/1994	18x24	-	LR

Facilities Transfer - Signs

SIGN CODE	LOC. REF.	STREET NAME	STREET_SUFFIX	LOC. REF.	CROSS STREET	Combo113	DATE INSTALLED	SIZE	MUTCD	SUFFIX
R1	WS	NINTH	ST	NO	NORTH PACIFIC	AVE	10/1/1968	30x30	R1-1	
R2	NS	SOUTH PACIFIC	AVE	EO	TWENTY SIXTH	ST	1/29/1985	24x30	R2-1	15
NR26PT	SS	SOUTH PACIFIC	AVE	EO	TWENTY SIXTH	ST	1/29/1985	12x18	-	
G93	SS	SOUTH PACIFIC	AVE	EO	TWENTY SIXTH	ST	12/11/1996	18x24	D11-1	
R2	NS	SOUTH PACIFIC	AVE	EO	BROADWAY	-	1/29/1985	24x30	R2-1	15
NR26PT	SS	SOUTH PACIFIC	AVE	WO	BROADWAY	-		12x18	-	
R1	SS	SOUTH PACIFIC	AVE	WO	BROADWAY	-	10/30/1973	30x30	R1-1	
R10A	SS	SOUTH PACIFIC	AVE	WO	BROADWAY	-	10/30/1973	24x18	R6-2	
NR26PT	SS	SOUTH PACIFIC	AVE	EO	BROADWAY	-	1/29/1985	12x18	-	
R26T	SS	EIGHTEENTH	ST	AT	SOUTH PACIFIC	AVE	1/29/1985	12x18	-	LR
NR26PT	NS	SOUTH PACIFIC	AVE	WO	EIGHTH	ST	1/29/1985	12x18	-	
NR26PT	SS	SOUTH PACIFIC	AVE	WO	EIGHTH	ST	1/29/1985	12x18	-	
G93	SS	SOUTH PACIFIC	AVE	WO	EIGHTH	ST	12/11/1996	18x24	D11-1	
R30S	SS	SOUTH PACIFIC	AVE	AT	FOURTH	ST		18x24	-	
G93	SS	SOUTH PACIFIC	AVE	EO	BROADWAY	-		18x24	D11-1	
R28	SS	SOUTH PACIFIC	AVE	EO	BROADWAY	-		12x18	-	L
R26T	SS	ELEVENTH	ST	AT	SOUTH PACIFIC	AVE	1/29/1985	12x18	-	LR
NR26PT	SS	SOUTH PACIFIC	AVE	WO	ELEVENTH	ST		12x18	-	
NR26PT	WS	FIFTEENTH	ST	SO	SOUTH PACIFIC	AVE	1/29/1985	12x18	-	
NR26PT	MO	SOUTH PACIFIC	AVE	EO	FIFTEENTH	ST	1/29/1985	12x18	-	
G93	SS	SOUTH PACIFIC	AVE	AT	FIFTH	ST		18x24	D11-1	
NR26PT	SS	SOUTH PACIFIC	AVE	WO	FIFTH	ST	12/11/1996	12x18	-	
NR26PT	NS	SOUTH PACIFIC	AVE	WO	FOURTEENTH	ST	1/29/1985	12x18	-	
NR26PT	SS	SOUTH PACIFIC	AVE	WO	FOURTEENTH	ST	1/29/1985	12x18	-	
NR26PT	NS	SOUTH PACIFIC	AVE	AT	FOURTH	ST	1/29/1985	12x18	-	
NR26PT	SS	SOUTH PACIFIC	AVE	AT	FOURTH	ST	1/29/1985	12x18	-	
R1	SS	SOUTH PACIFIC	AVE	WO	NINETEENTH	ST	1/29/1985	30x30	R1-1	
NR26PT	SS	SOUTH PACIFIC	AVE	EO	NINETEENTH	ST	1/29/1985	12x18	-	
R2	NS	SOUTH PACIFIC	AVE	EO	NINETEENTH	ST	1/29/1985	24x30	R2-1	15
G93	SS	SOUTH PACIFIC	AVE	EO	NINETEENTH	ST	1/29/1985	24x18	D11-1	
NR26PT	SS	SOUTH PACIFIC	AVE	EO	NINETEENTH	ST	1/29/1985	12x18	-	
G93	SS	SOUTH PACIFIC	AVE	AT	NINTH	ST	1/29/1985	18x24	D11-1	
R26T	SS	NINTH	ST	AT	SOUTH PACIFIC	AVE	1/29/1985	12x18	-	LR
NR26PT	SS	SOUTH PACIFIC	AVE	EO	NINTH	ST		12x18	-	

Facilities Transfer - Signs

SIGN CODE	LOC. REF.	STREET NAME	STREET_SUFFIX	LOC. REF.	CROSS STREET	Combo113	DATE INSTALLED	SIZE	MUTCD	SUFFIX
R41	NS	SOUTH PACIFIC	AVE	EO	SECOND	ST	1/29/1985	30x36		
NR26PT	SS	SOUTH PACIFIC	AVE	EO	SECOND	ST	1/29/1985	12x18	-	
NR26PT	SS	SOUTH PACIFIC	AVE	EO	SECOND	ST	10/30/1973	12x18	-	
G93	SS	SOUTH PACIFIC	AVE	WO	SECOND	ST		24x18	D11-1	
NR26PT	SS	SOUTH PACIFIC	AVE	WO	SECOND	ST		12x18	-	
NR26PT	SS	SOUTH PACIFIC	AVE	EO	SECOND	ST		12x18	-	
R26T	SS	SOUTH PACIFIC	AVE	AT	SEVENTEENTH	ST	1/29/1985	12x18	-	LR
NR26PT	SS	SOUTH PACIFIC	AVE	EO	SEVENTEENTH	ST	1/29/1985	12x18	-	
G93	SS	SOUTH PACIFIC	AVE	AT	SEVENTH	ST	1/29/1985	24x18	D11-1	
R10A	SS	SOUTH PACIFIC	AVE	AT	SEVENTH	ST	1/29/1985	24x18	R6-2	
R26T	MO	SEVENTH	ST	SO	SOUTH PACIFIC	AVE	8/9/1979	12x18	-	LR
R26T	MO	SIXTEENTH	ST	SO	SOUTH PACIFIC	AVE		12x18	-	LR
NR26PT	SS	SOUTH PACIFIC	AVE	WO	SIXTEENTH	ST	1/29/1985	12x18	-	
R26T	SS	SOUTH PACIFIC	AVE	AT	SIXTH	ST	1/29/1985	12x18	-	LR
NR26PT	SS	SOUTH PACIFIC	AVE	EO	SIXTH	ST	1/29/1985	12x18	-	
R26T	SS	SOUTH PACIFIC	AVE	AT	THIRD	ST	1/29/1985	12x18	-	LR
NR26PT	SS	SOUTH PACIFIC	AVE	AT	TWELFTH	ST		12x18	-	
NR26PT	SS	SOUTH PACIFIC	AVE	WO	TWENTY FIFTH	ST	1/29/1985	12x18	-	
R10A	SS	SOUTH PACIFIC	AVE	WO	TWENTY FIFTH	ST	1/29/1985	24x18	R6-2	
R26T	MO	TWENTY FIFTH	SH	SO	SOUTH PACIFIC	AVE	1/29/1985	12x18	-	LR
G93	NS	SOUTH PACIFIC	AVE	AT	TWENTY FIRST	ST	10/30/1973	24x18	D11-1	
NR26PT	SS	SOUTH PACIFIC	AVE	EO	TWENTY FIRST	ST	10/30/1973	12x18	-	
NR26PT	SS	SOUTH PACIFIC	AVE	EO	TWENTY FIRST	ST	1/29/1985	12x18	-	
NR26PT	SS	SOUTH PACIFIC	AVE	EO	TWENTY FIRST	ST	1/29/1985	12x18	-	
NR26PT	SS	SOUTH PACIFIC	AVE	WO	TWENTY FIRST	ST		12x18	-	
R10A	SS	SOUTH PACIFIC	AVE	WO	TWENTY SECOND	ST	1/29/1985	18x24	R6-2	
NR26PT	SS	SOUTH PACIFIC	AVE	WO	TWENTY SECOND	ST	1/29/1985	12x18	-	
NR26PT	SS	SOUTH PACIFIC	AVE	EO	TWENTY SECOND	ST	12/11/1996	12x18	-	
NR26PT	SS	SOUTH PACIFIC	AVE	WO	TWENTY THIRD	ST	1/29/1985	12x18	-	
G93	SS	SOUTH PACIFIC	AVE	EO	TWENTY THIRD	ST	1/29/1985	24x18	D11-1	
R1	WS	SEVENTEENTH	ST	NO	NORTH PACIFIC	AVE	2/7/1985	30x30	R1-1	
R30S	WS	SEVENTH	ST	SO	COAST	HWY	8/25/1994	18x24	-	
R1	ES	SEVENTH	ST	SO	NORTH PACIFIC	AVE	9/3/1968	24x24	R1-1	
R1	WS	SEVENTH	ST	NO	NORTH PACIFIC	AVE	9/3/1968	30x30	R1-1	

Facilities Transfer - Signs

SIGN CODE	LOC. REF.	STREET NAME	STREET_SUFFIX	LOC. REF.	CROSS STREET	Combo113	DATE INSTALLED	SIZE	MUTCD	SUFFIX
R1	WS	SEVENTH	ST	NO	SOUTH PACIFIC	AVE	2/7/1985	30x30	R1-1	
R1	WS	SIXTEENTH	ST	NO	NORTH PACIFIC	AVE	2/7/1980	30x30	R1-1	
R1	ES	SIXTEENTH	ST	SO	NORTH PACIFIC	AVE	2/7/1980	30x30	R1-1	
R10A	WS	SIXTEENTH	ST	NO	SOUTH PACIFIC	AVE	12/11/1996	18x24	R6-2	
R1	WS	SIXTEENTH	ST	NO	SOUTH PACIFIC	AVE	2/7/1980	30x30	R1-1	
R1	WS	SIXTH	ST	NO	NORTH PACIFIC	AVE	5/13/1968	30x30	R1-1	
R1	WS	TENTH	ST	NO	NORTH PACIFIC	AVE	1/29/1985	24x24	R1-1	
R1	ES	TENTH	ST	SO	NORTH PACIFIC	AVE	1/29/1985	30x30	R1-1	
R10A	ES	TENTH	ST	SO	NORTH PACIFIC	AVE	1/29/1985	24x18	R6-2	
R1	WS	TENTH	ST	NO	SOUTH PACIFIC	AVE	1/29/1985	30x30	R1-1	
R1	WS	TWELFTH	ST	NO	NORTH PACIFIC	AVE	1/10/1969	30x30	R1-1	
R26	ES	TWELFTH	ST	NO	NORTH PACIFIC	AVE	2/25/1985	12x18	-	
R26T	MO	TWENTIETH	ST	SO	SOUTH PACIFIC	ST	8/25/1994	12x18	-	LR
R1	WS	TWENTIETH	ST	NO	NORTH PACIFIC	AVE	12/27/1968	30x30	R1-1	
R26T	MO	TWENTY FIFTH	ST	SO	SOUTH PACIFIC	ST	8/25/1994	12x18	-	LR
R1	WS	TWENTY FIFTH	ST	NO	NORTH PACIFIC	AVE	2/25/1985	30x30	R1-1	
R1	ES	TWENTY FIFTH	ST	SO	NORTH PACIFIC	AVE	2/25/1985	30x30	R1-1	
R10A	ES	TWENTY FIFTH	ST	SO	NORTH PACIFIC	AVE	12/12/1996	18x24	R6-2	
R1	WS	TWENTY FIFTH	ST	NO	SOUTH PACIFIC	AVE	2/25/1985	30x30	R1-1	
NR26PT	MO	TWENTY FIFTH	ST	SO	SOUTH PACIFIC	AVE	2/25/1985	12x18	-	
R1	WS	TWENTY FIRST	ST	NO	NORTH PACIFIC	AVE	2/25/1985	30x30	R1-1	
R26T	MO	TWENTY FOURTH	ST	SO	SOUTH PACIFIC	ST	8/25/1994	18x24	-	LR
R1	WS	TWENTY FOURTH	ST	NO	NORTH PACIFIC	AVE	5/20/1971	30x30	R1-1	
R26T	MO	TWENTY SECOND	ST	SO	SOUTH PACIFIC	ST	8/25/1994	18x24	-	LR
R1	WS	TWENTY SECOND	ST	NO	NORTH PACIFIC	AVE	12/27/1968	30x30	R1-1	
R1	ES	TWENTY SECOND	ST	SO	NORTH PACIFIC	AVE	2/25/1985	30x30	R1-1	
R1	WS	TWENTY SECOND	ST	NO	SOUTH PACIFIC	AVE	2/25/1985	30x30	R1-1	
R26T	MO	TWENTY SIXTH	ST	SO	SOUTH PACIFIC	ST	8/25/1994	18x24	-	LR
R1	WS	TWENTY SIXTH	ST	NO	NORTH PACIFIC	AVE	5/20/1971	30x30	R1-1	
R26T	MO	TWENTY THIRD	ST	SO	SOUTH PACIFIC	ST	8/25/1994	12x18	-	LR
R1	WS	TWENTY THIRD	ST	NO	NORTH PACIFIC	AVE	2/25/1985	30x30	R1-1	
R26	WS	WARNER	AVE	SO	NORTH PACIFIC	AVE	4/18/1968	12x18	-	
R2	NS	BAYVIEW	DR	WO	BROADWAY			24x30	R2-1	15
NR26PT	WS	ALLEY-BTWN 8TH & 9TH ST	ALLEY	SO	NORTH PACIFIC	AVE		12x18	-	

Facilities Transfer - Signs

SIGN CODE	LOC. REF.	STREET NAME	STREET_SUFFIX	LOC. REF.	CROSS STREET	Combo113	DATE INSTALLED	SIZE	MUTCD	SUFFIX
R28	WS	ALLEY-BTWN 10TH & 11TH ST	ALLEY	NO	NORTH PACIFIC	AVE		12x18	-	R
R28	WS	ALLEY-BTWN 10TH & 11TH ST	ALLEY	NO	NORTH PACIFIC	AVE		12x18	-	L
R10A	WS	ALLEY-BTWN 14TH & BROADWAY	ALLEY	NO	NORTH PACIFIC	AVE		18x24	R6-2	
R1	WS	FOURTH	ST	NO	SOUTH PACIFIC	AVE		30x30	R1-1	
R10A	WS	FOURTH	ST	NO	SOUTH PACIFIC	AVE		18x24	R6-2	
R26	ES	PASCHALLS	LN	NO	NORTH PACIFIC	AVE		12x18	-	
R26	ES	PASCHALLS	LN	NO	NORTH PACIFIC	AVE		12x18	-	
NR26PT	WS	PASCHALLS	LN	NO	NORTH PACIFIC	AVE		12x18	-	
R26	ES	PASCHALLS	LN	NO	NORTH PACIFIC	AVE		12x18	-	
R26	ES	PASCHALLS	LN	NO	NORTH PACIFIC	AVE		12x18	-	
R26	ES	PASCHALLS	LN	NO	NORTH PACIFIC	AVE		12x18	-	
R26	ES	PASCHALLS	LN	NO	NORTH PACIFIC	AVE		12x18	-	
R10A	WS	ALLEY-BTWN 15TH & 16TH ST	ALLEY	NO	NORTH PACIFIC	AVE		18x24	R6-2	
R26	ES	ALLEY-BTWN 15TH & 16TH ST	ALLEY	NO	NORTH PACIFIC	AVE		12x18	-	
NR26S	WS	ALLEY-BTWN 16TH & 17TH ST	ALLEY	NO	NORTH PACIFIC	AVE		12x18	-	
R10A	WS	NINETEENTH	ST	NO	NORTH PACIFIC	AVE		18x24	R6-2	
R10A	WS	TWENTY FIRST	ST	NO	NORTH PACIFIC	AVE		18x24	R6-2	
R10A	WS	TWENTY SECOND	ST	NO	NORTH PACIFIC	AVE		18x24	R6-2	
R10A	WS	TWENTY FIFTH	ST	NO	NORTH PACIFIC	AVE		18x24	R6-2	
R26	WS	ALLEY-BTWN 25TH & 26TH ST	ALLEY	NO	NORTH PACIFIC	AVE		12x18	-	
R28	WS	ALLEY-BTWN 25TH & 26TH ST	ALLEY	NO	NORTH PACIFIC	AVE		12x18	-	L
R28	ES	ALLEY-BTWN 26TH & ANDERSON	ALLEY	NO	NORTH PACIFIC	AVE		12x18	-	L
R26	ES	ALLEY-BTWN 26TH & ANDERSON	ALLEY	NO	NORTH PACIFIC	AVE		12x18	-	
R28	ES	ALLEY-BTWN 26TH & ANDERSON	ALLEY	NO	NORTH PACIFIC	AVE		12x18	-	R
W53	SS	BAYVIEW	DR	EO	BROADWAY	-		36x36	-	
W53	NS	BAYVIEW	DR	EO	BROADWAY	-		30x30	-	
R2	NS	BAYVIEW	DR	EO	BROADWAY	-		24x30	R2-1	15
NR39	NS	BAYVIEW	DR	WO	BROADWAY	-		18x24	-	
R1	NS	SOUTH PACIFIC	AVE	WO	SEVENTH	ST	8/13/1997	30x30	R1-1	
R1	ES	FIFTH	ST	SO	NORTH PACIFIC	AVE		24x24	R1-1	
R26	SS	SOUTH PACIFIC	AVE	EO	TWENTY FOURTH	ST	8/11/1998	12x18	-	
R1-4	WS	SEVENTH	ST	NO	NORTH PACIFIC	AVE	9/15/1998	6x18	R1-4	
R1-4	NS	SOUTH PACIFIC	AVE	WO	SEVENTH	ST	9/15/1998	6x18	R1-4	
R1-4	ES	SEVENTH	ST	SO	NORTH PACIFIC	AVE	9/15/1998	6x18	R1-4	

Facilities Transfer - Signs

SIGN CODE	LOC. REF.	STREET NAME	STREET_SUFFIX	LOC. REF.	CROSS STREET	Combo113	DATE INSTALLED	SIZE	MUTCD	SUFFIX
R1-4	WS	SEVENTH	ST	NO	SOUTH PACIFIC	AVE	9/15/1998	6x18	R1-4	
R26	WS	WARNER	AVE	SO	NORTH PACIFIC	AVE	9/13/1998	12x18	-	
R26	WS	WARNER	AVE	SO	NORTH PACIFIC	AVE	9/13/1998	12x18	-	
R26(S)	WS	WARNER	AVE	SO	NORTH PACIFIC	AVE	9/13/1998	12x18	-	
R26(S)	WS	WARNER	AVE	SO	NORTH PACIFIC	AVE	9/13/1998	12x18	-	
R26(S)	ES	WARNER	AVE	SO	NORTH PACIFIC	AVE	9/13/1998	12x18	-	
R26(S)	ES	WARNER	AVE	SO	NORTH PACIFIC	AVE	9/13/1998	12x18	-	
R26	ES	WARNER	AVE	NO	NORTH PACIFIC	AVE	9/13/1998	12x18	-	
R17	NS	SOUTH PACIFIC	AVE	EO	THIRD	ST	8/31/1998	24x24	R3-2	
R11	NS	SOUTH PACIFIC	AVE	EO	THIRD	ST	8/31/1998	30x30	R5-1	
R26	ES	TWELFTH	ST	NO	SOUTH PACIFIC	AVE	2/24/1999	12x18	-	
R30S	NS	NORTH PACIFIC	AVE	WO	WARNER	AVE	7/7/2000	18x24	-	
R30S	SS	NORTH PACIFIC	AVE	EO	ANDERSON	AVE	7/7/2000	18x24	-	
R30S	WS	ALLEY-BTWN 26TH & ANDERSON	ALLEY	NO	NORTH PACIFIC	AVE	7/7/2000	18x24	-	
R30S	ES	TWENTY SIXTH	ST	SO	NORTH PACIFIC	AVE	7/7/2000	18x24	-	
R30S	WS	ALLEY- BTWN 25TH & 26TH ST	ALLEY	NO	NORTH PACIFIC	AVE	7/7/2000	18x24	-	
R30S	ES	TWENTY FIFTH	ST	SO	NORTH PACIFIC	AVE	7/7/2000	18x24	-	
R30S	ES	ALLEY-BTWN 24TH & 25TH ST	ALLEY	SO	NORTH PACIFIC	AVE	7/7/2000	18x24	-	
R30S	ES	TWENTY FOURTH	ST	SO	NORTH PACIFIC	AVE	7/7/2000	18x24	-	
R30S	ES	ALLEY-BTWN 23RD & 24TH ST	ALLEY	SO	NORTH PACIFIC	AVE	7/7/2000	18x24	-	
R30S	ES	ALLEY-BTWN 22ND & 23RD ST	ALLEY	SO	NORTH PACIFIC	AVE	7/7/2000	18x24	-	
R30S	ES	TWENTY SECOND	ST	SO	NORTH PACIFIC	AVE	7/7/2000	18x24	-	
R30S	ES	TWENTY FIRST	ST	NO	NORTH PACIFIC	AVE	7/7/2000	18x24	-	
R30S	ES	TWENTIETH	ST	SO	NORTH PACIFIC	AVE	7/7/2000	18x24	-	
R30S	WS	NINETEENTH	ST	NO	NORTH PACIFIC	AVE	7/7/2000	18x24	-	
R30S	WS	EIGHTEENTH	ST	NO	NORTH PACIFIC	AVE	7/7/2000	18x24	-	
R30S	ES	SEVENTEENTH	ST	SO	NORTH PACIFIC	AVE	7/7/2000	18x24	-	
R30S	WS	ALLEY-BTWN 16TH & 17TH ST	ALLEY	NO	NORTH PACIFIC	AVE	7/7/2000	18x24	-	
R30S	ES	SIXTEENTH	ST	SO	NORTH PACIFIC	AVE	7/7/2000	12x18	-	
R30S	ES	ALLEY-BTWN 15TH & 16TH ST	ALLEY	SO	NORTH PACIFIC	AVE	7/7/2000	12x18	-	
R30S	ES	FIFTEENTH	ST	SO	NORTH PACIFIC	AVE	7/7/2000	12x18	-	
R30S	ES	ALLEY-BTWN 14TH & 15TH ST	ALLEY	SO	NORTH PACIFIC	AVE	7/7/2000	18x24	-	
R30S	ES	FOURTEENTH	ST	NO	NORTH PACIFIC	AVE	7/7/2000	12x18	-	
R30S	WS	BROADWAY	-	NO	NORTH PACIFIC	AVE	7/7/2000	18x24	-	

Facilities Transfer - Signs

SIGN CODE	LOC. REF.	STREET NAME	STREET_SUFFIX	LOC. REF.	CROSS STREET	Combo113	DATE INSTALLED	SIZE	MUTCD	SUFFIX
R30S	ES	ALLEY-BTWN 12TH & BROADWAY	ALLEY	NO	NORTH PACIFIC	AVE	7/7/2000	18x24	-	
R30S	ES	TWELFTH	ST	NO	NORTH PACIFIC	AVE	7/7/2000	18x24	-	
R30S	WS	ALLEY-BTWN 12TH & BROADWAY	ALLEY	NO	NORTH PACIFIC	AVE	7/7/2000	18x24	-	
R30S	ES	ELEVENTH	ST	SO	NORTH PACIFIC	AVE	7/7/2000	12x18	-	
R30S	ES	ALLEY-BTWN 10TH & 11TH ST	ALLEY	SO	NORTH PACIFIC	AVE	7/7/2000	18x24	-	
R30S	ES	TENTH	ST	NO	NORTH PACIFIC	AVE	7/7/2000	18x24	-	
R30S	ES	ALLEY-BTWN 9TH & 10TH ST	ALLEY	SO	NORTH PACIFIC	AVE	7/7/2000	18x24	-	
R30S	ES	NINTH	ST	SO	NORTH PACIFIC	AVE	7/7/2000	18x24	-	
R30S	ES	ALLEY-BTWN 8TH & 9TH ST	ALLEY	SO	NORTH PACIFIC	AVE	7/7/2000	18x24	-	
R30S	WS	EIGHTH	ST	NO	NORTH PACIFIC	AVE	7/7/2000	18x24	-	
R30S	WS	ALLEY-BTWN 7TH & 8TH ST	ALLEY	NO	NORTH PACIFIC	AVE	7/7/2000	18x24	-	
R30S	WS	ALLEY- BTWN 6TH & 7TH ST	ALLEY	NO	NORTH PACIFIC	AVE	7/7/2000	18x24	-	
R30S	WS	SIXTH	ST	NO	NORTH PACIFIC	AVE	7/7/2000	18x24	-	
R30S	WS	PASCHALLS	LN	NO	NORTH PACIFIC	AVE	7/7/2000	18x24	-	
R30S	WS	FIFTH	ST	NO	NORTH PACIFIC	AVE	7/7/2000	18x24	-	
R30S	WS	ALLEY-BTWN 4TH & 5TH ST	ALLEY	NO	NORTH PACIFIC	AVE	7/7/2000	18x24	-	
R30S	WS	FOURTH	ST	NO	NORTH PACIFIC	AVE	7/7/2000	18x24	-	
R30S	ES	ALLEY-BTWN 3RD & 4TH ST	ALLEY	NO	NORTH PACIFIC	AVE	7/7/2000	18x24	-	
NR39	NS	BAYVIEW	DR	WO	BROADWAY	-	7/7/2000	18x24	-	
NR39	SS	BAYVIEW	DR	WO	BROADWAY	-	7/7/2000	18x24	-	
R30S	WS	ALLEY-BTWN 14TH & BROADWAY	ALLEY	NO	NORTH PACIFIC	AVE	7/7/2000	18x24	-	
R30S	WS	ALLEY-BTWN 14TH & BROADWAY	ALLEY	SO	COAST	HWY	7/7/2000	18x24	-	
R30S	WS	ALLEY-BTWN 11TH & 12TH ST	ALLEY	NO	NORTH PACIFIC	AVE	7/7/2000	18x24	-	
R30S	WS	ALLEY-BTWN 9TH & 10TH ST	ALLEY	NO	NORTH PACIFIC	AVE	7/7/2000	18x24	-	
R30S	WS	ALLEY-BTWN 8TH & 9TH ST	ALLEY	NO	NORTH PACIFIC	AVE	7/7/2000	18x24	-	
R30S	WS	ALLEY-BTWN 4TH & 5TH ST	ALLEY	NO	NORTH PACIFIC	AVE	7/7/2000	18x24	-	
R30S	WS	FOURTH	ST	NO	NORTH PACIFIC	AVE	7/7/2000	18x24	-	
R30S	ES	ALLEY - BTWN 3RD & 4TH ST	ALLEY	NO	NORTH PACIFIC	AVE	7/7/2000	18x24	-	
NR39	NS	BAYVIEW	DR	WO	BROADWAY	-	7/7/2000	18x24	-	
NR39	SS	BAYVIEW	DR	WO	BROADWAY	-	7/7/2000	18x24	-	
NR26PT	NS	NORTH PACIFIC	AVE	WO	PASCHALLS	LN		12x18	-	
R30S	NS	NORTH PACIFIC	AVE	WO	PASCHALLS	LN		18x24	-	
NR26PT	SS	NORTH PACIFIC	AVE	EO	ANDERSON	ST		12x18	-	
W57	SS	NORTH PACIFIC	AVE	AT	ANDERSON	ST		36x18	W1-6	

Facilities Transfer - Signs

SIGN CODE	LOC. REF.	STREET NAME	STREET_SUFFIX	LOC. REF.	CROSS STREET	Combo113	DATE INSTALLED	SIZE	MUTCD	SUFFIX
NR26PT	SS	SOUTH PACIFIC	AVE	AT	TWENTY THIRD	ST		12x18	-	
NR39	SS	BAYVIEW	DR	WO	BROADWAY	-		18x24	-	
R1	NS	BAYVIEW	DR	EO	BROADWAY	-		30x30	R1-1	
NR39	NS	BAYVIEW	DR	EO	BROADWAY	-		18x24	-	
NR39	NS	BAYVIEW	DR	EO	BROADWAY	-		18x24	-	
R2	NS	SOUTH PACIFIC	AVE	EO	SEVENTH	ST	2/14/2001	24x30	R2-1	15
W53	SS	SOUTH PACIFIC	AVE	EO	SECOND	ST		30x30		
NR39	SS	BAYVIEW	DR	WO	BROADWAY	-	8/1/2001	18x24	-	
R10A	WS	TWENTIETH	ST	NO	NORTH PACIFIC	AVE	2/20/2002	18x24	R6-2	
R10A	MO	TWENTIETH	ST	SO	NORTH PACIFIC	AVE	2/20/2002	18x24	R6-2	
R28	ES	EIGHTEENTH	ST	SO	SOUTH PACIFIC	AVE	6/18/2002	12x18	-	R
SW1	SS	SOUTH PACIFIC	ST	WO	BROADWAY	-	2/23/2005	18x24	W4-4P	
-	NS	SOUTH PACIFIC	AVE	EO	FIFTH	ST	8/10/2002	30x30	W15-1	
-	SS	NORTH PACIFIC	AVE	AT	THIRD	ST	8/10/2002	30x30	W15-1	
R48-1	NS	NORTH PACIFIC	AVE	EO	SECOND	ST	10/23/2002	12x24	-	
R48-1	SS	NORTH PACIFIC	AVE	WO	BROADWAY	-	10/23/2002	12x24	-	
R48-1	NS	SOUTH PACIFIC	AVE	EO	TWENTY SIXTH	ST	10/23/2002	12x24	-	
R48-1	NS	SOUTH PACIFIC	AVE	EO	BROADWAY	-	10/23/2002	12x24	-	
NR26PT	NS	NORTH PACIFIC	AVE	WO	EIGHTH	ST	3/29/2004	12x18	-	
R28	SS	SOUTH PACIFIC	AVE	WO	BROADWAY	-		12x18	-	R
SW1	NS	NORTH PACIFIC	AVE	EO	BROADWAY	-	2/23/2005	24x12	W4-4p	
R26	ES	ALLEY- BTWN 25TH & 26TH ST	ALLEY	NO	NORTH PACIFIC	AVE	2/20/2002	12x18	-	
R1	WS	ALLEY-BTWN 12TH & BROADWAY	ALLEY	NO	NORTH PACIFIC	AVE		24x24	R1-1	
R10A	WS	SECOND	ST	NO	SOUTH PACIFIC	AVE		18x24	R6-2	
R1-2	NS	NORTH PACIFIC	AVE	AT	WARNER	AVE	2/5/2007	24x24	R1-2	
NR26T	ES	TWELFTH	ST	SO	COAST	HWY	2/25/1985	12x18	-	
R28	WS	WARNER	AVE	SO	COAST	HWY		12x18	-	L
R28(S)	ES	WARNER	AVE	SO	COAST	HWY		12x18	-	R
R23	WS	BROADWAY	-	NO	COAST	HWY		12x18	-	
R23	ES	BROADWAY	-	NO	COAST	HWY		12x18	-	M
R23	WS	BROADWAY	-	NO	COAST	HWY		12x18	-	M
R36	ES	BROADWAY	-	NO	COAST	HWY	10/28/1997	24x24	-	
R28	ES	BROADWAY	-	NO	COAST	HWY	6/12/1997	12x18	-	R
R23	ES	BROADWAY	-	NO	COAST	HWY		12x18	-	M

Facilities Transfer - Signs

SIGN CODE	LOC. REF.	STREET NAME	STREET_SUFFIX	LOC. REF.	CROSS STREET	Combo113	DATE INSTALLED	SIZE	MUTCD	SUFFIX
R28	WS	BROADWAY	-	NO	COAST	HWY		12x18	-	L
R28	WS	BROADWAY	-	NO	COAST	HWY	6/12/1997	12x18	-	L
R23	ES	BROADWAY	-	NO	COAST	HWY		12x18	-	
R23	ES	BROADWAY	-	NO	COAST	HWY		12x18	-	
R26	ES	PASCHALLS	-	SO	COAST	HWY	7/17/1980	12x18	-	
R30S	ES	PARK	-	NO	COAST	HWY	1/18/2001	18x24	-	
W53	ES	PARK	-	NO	COAST	HWY	1/29/1985	36x36	-	
R28	ES	PARK	-	NO	COAST	HWY	1/29/1985	12x18	-	L
R26	WS	PARK	-	NO	COAST	HWY	1/29/1985	12x18	-	
R28	WS	PARK	-	NO	COAST	HWY	1/29/1985	12x18	-	L
R36	ES	TWENTIETH	ST	SO	COAST	HWY	4/8/1985	24x24	-	
NR7PT	ES	SUNSET BEACH PARKING LOT	-	NO	SOUTH PACIFIC	AVE		18x30	-	
NR7PT	NS	SUNSET BEACH PARKING LOT	-	WO	NORTH PACIFIC	AVE		18x30	-	

Facilities to Transfer - Other Items

Street Lights

Size (Lumens)	# Lights
5800L HPSV	61
9500L HPSV	3

Traffic Signals (5) - Cost Share Agreement with Caltrans

Intersection	County Share
Pacific Coast Hwy at Admiralty	25%
PCH at Anderson/Phillips	25%
PCH at Broadway	50%
PCH at Coral Cay/5th	25%
PCH at Warner	25%

Transfer of Maintenance Responsibility

Cross Gutters - 31
Catch Basins - 5