

**ORANGE COUNTY TRAFFIC COMMITTEE**

COMMITTEE REPORT OF:           October 9, 2025                                   ITEM A

SUPERVISORIAL DISTRICT:       All

**SUBJECT:**                           Establish Stop Sign Control

**LOCATION:**                       All Unincorporated County Islands

**INITIATED BY:**                 Programming

**INVESTIGATOR:**               Wei Zhu

**REQUEST:**                     HSIP Cycle 12\_Stop Sign Warrant Study

**DATA:**                         Fehr & Peers

**LOCATION MAP**

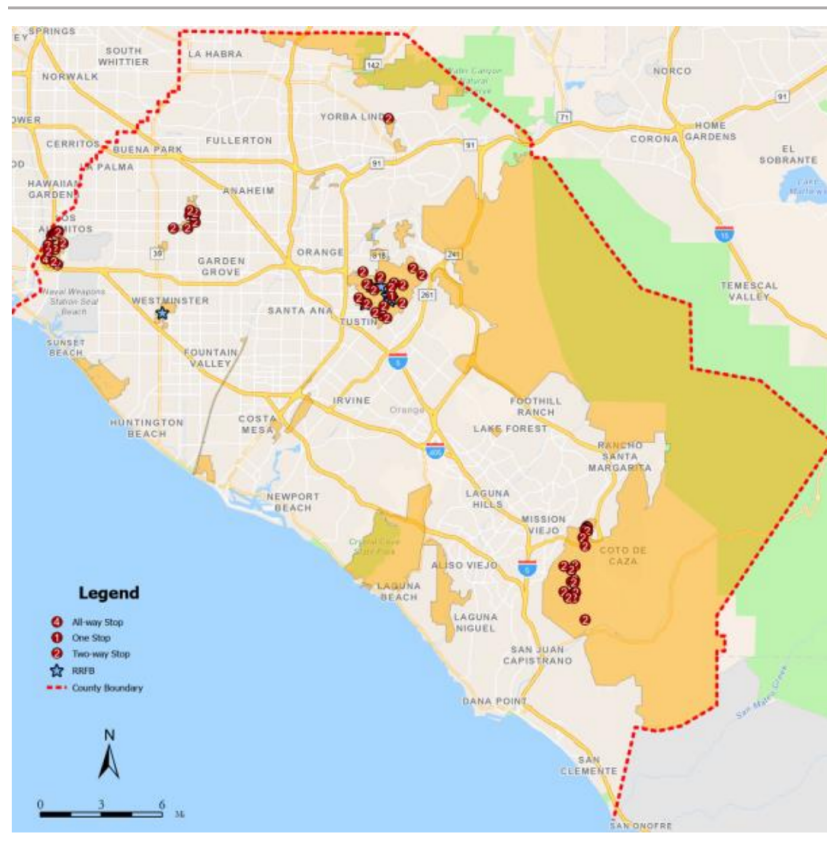

COMMITTEE REPORT OF: October 9, 2025

ITEM A

**BACKGROUND INFORMATION**

The County of Orange received Cycle 12 funding from the Highway Safety Improvement Program (HSIP) to install signs, and pavement markers at uncontrolled intersections across unincorporated Orange County. To enhance safety on County-maintained roadways, 61 uncontrolled intersections were identified. Of these, 3 were evaluated for All-Way Stop Control (AWSC) and 58 for Side-Street Stop Control (SSSC). The warrant study, prepared by Fehr & Peers, one of the County's on-call A-E consultants, is enclosed in Appendix A.

**TRAFFIC DATA AND ANALYSIS**

The traffic data used in this study consisted of collision records from the Statewide Integrated Traffic Records System (SWITRS) for the seven-year period from 2017 through 2023, sixteen-hour (6:00 a.m. to 10:00 p.m.) multimodal intersection turning movement counts, peak eight-hour intersection volumes, and peak-hour pedestrian volumes.

In accordance with State and local guidance, including the California Manual on Uniform Traffic Control Devices (CA MUTCD, 2014 Edition, Revision 9, 2025) and the Orange County Traffic Manual (OCTM, 2007), the standard criteria for stop sign installation are based on collision history, multimodal traffic volumes, and approach speeds. Optional criteria may also be applied, at the discretion of engineering judgment, to account for conditions such as left-turn conflicts, vehicle-pedestrian conflicts, or sight distance limitations.

All-Way Stop Control (AWSC) Evaluation: None of the three study locations satisfied the standard criteria; however, all three met one optional criterion due to elevated levels of vehicle-pedestrian conflict.

Side-Street Stop Control (SSSC) Evaluation: None of the 58 study locations satisfied the collision criteria outlined in the CA MUTCD, and only one location satisfied the collision criteria in the OCTM. Given that the historical average collision rate in Orange County has been lower than the statewide average, the evaluation applied a modified threshold of one correctable collision within a twelve-month period, instead of the standard two, to support a proactive safety approach. Using this adjusted criterion, the number of qualifying locations increased from one to eight. When combined with those locations that satisfied the volume criteria, a total of 18 locations met the warrants for SSSC installation.

**RECOMMENDATION**

1. Establish All-Way Stop Control at Shakespeare Drive and Wembley Road in Rossmoor.
2. Establish All-Way Stop Control at Piedmont Avenue and Wembley Road in Rossmoor.
3. Establish All-Way Stop Control at Gertrude Drive and Kensington Road in Rossmoor.
  
4. Establish Side-Street Stop Control at Quail Run Road and Donniss Road in Rossmoor.

COMMITTEE REPORT OF: October 9, 2025

ITEM A

5. Establish Side-Street Stop Control at Donnie Ann Road and Donnis Road in Rossmoor.
6. Establish Side-Street Stop Control at Kensington Road and Chesney Drive in Rossmoor.
7. Establish Side-Street Stop Control at Chesney Drive and Loch Lomond Road in Rossmoor.
8. Establish Side-Street Stop Control at Weatherby Road and Huntley Drive in Rossmoor.
9. Establish Side-Street Stop Control at Silver Fox Road and Saint Albans Drive in Rossmoor.
10. Establish Side-Street Stop Control at Yardley Street and Harvest Lane in Anaheim Islands.
11. Establish Side-Street Stop Control at Bienville Avenue and Antigua Street in Anaheim Islands.
12. Establish Side-Street Stop Control at Guinida Lane and D'Este Drive in Anaheim Islands.
13. Establish Side-Street Stop Control at Antigua Street and Guinida Lane in Anaheim Islands.
14. Establish Side-Street Stop Control at Banta Avenue and Endry Street in Anaheim Islands.
15. Establish Side-Street Stop Control at Warren Avenue and Clarissa Lane in North Tustin.
16. Establish Side-Street Stop Control at La Loma Drive and Colony Drive/Heathcliff Drive in North Tustin.
17. Establish Side-Street Stop Control at Kenneth Drive and Woodlawn Avenue in North Tustin.
18. Establish Side-Street Stop Control at Grassy Knoll Lane and Ledgewood Drive in Las Flores.
19. Establish Side-Street Stop Control at Mayback Lane and Dawnwood in Ladera Ranch.
20. Establish Side-Street Stop Control at Main Street and Reston Way in Ladera Ranch.
21. Establish Side-Street Stop Control at Ranunculus Street and Shively Road in Ladera Ranch.

**PUBLIC COMMENTS AND INPUT**

No comments were received from the public regarding this item.

**TRAFFIC COMMITTEE DISCUSSION**

Traffic Committee members approved the motion to establish All-Way Stop Control and Side-Street Stop Control at the intersections listed.

**BOARD ACTION NECESSARY TO ENACT THIS RECOMMENDATION**

1. Approve this report.
2. By resolution, establish All-Way Stop Control at the 3 intersections as listed.
3. By resolution, establish Side-Street Stop Control at the 18 intersections as listed.

# Memo

Date: September 15, 2025  
To: Wei Zhu, PE, TE, Orange County Public Works  
From: Diwu Zhou, PE and Joshua Geronimo, Fehr & Peers  
**Subject: HSIP Cycle 12 – Stop Sign Warrants Study**

---

The County of Orange received funding through Cycle 12 of the Highway Safety Improvement Program (HSIP) to install stop signs/bars/pavement markers at sixty-one (61) uncontrolled intersections throughout Unincorporated Orange County:

- All-Way Stop (Multi-Way Stop) at 3 of the 61 intersections.
- Side-Street Stop (Two-/One- Way Stop) at 58 of the 61 intersections.

Fehr & Peers completed a stop sign warrant study following guidance from the *California Manual on Uniform Traffic Control Devices* (CA MUTCD, 2014 Revision 9, 2025) and the *Orange County Traffic Manual* (OCTM, 2007). This memorandum summarizes the study scope, published guidance, methodology, and results of the assessment.

## Study Intersections

The study intersections are listed on the next page and are organized by regions within Unincorporated Orange County. The three intersections evaluated under all-way stop control (AWSC) criteria are denoted in bold text, and the remaining intersections were evaluated under side-street stop control (SSSC) criteria. Sixteen-hour (6:00 AM – 10:00 PM) multimodal intersection turning movement counts were collected at the study intersections on a typical weekday while schools were in session (see **Attachment A**). All intersections were subject to an in-person field visit to verify sight distance and geometric characteristics, such as the presence of dips, bumps, etc.

## Overview of Guidance for the Installation of Stop Signs

The installation of traffic control devices, such as stop signs, is pursuant to Section 21400 of the California Vehicle Code (CVC), which requires all traffic control devices and the criteria for installation of those traffic control devices to conform to the latest version *California Manual of Uniform Traffic Control Devices* (CA MUTCD). The current 2025 version of the CA MUTCD requires an engineering study and lists criteria that should be considered. Additional local guidance for the installation of stop signs is provided in the *Orange County Traffic Manual* (OCTM). However, the OCTM is not intended to be a substitute for engineering judgement.

## UNINCORPORATED COMMUNITY

0. Major Street & Minor Street

## ROSSMOOR

1. Quail Run Rd & Donnis Rd
2. Donnie Ann Rd & Donnis Rd
3. Kensington Rd & Chesney Dr
4. Wembley Rd & Chesney Dr
5. Chesney Dr & Loch Lomond Rd
6. Shakespeare Dr & Kensington Rd
- 7. Shakespeare Dr & Wembley Rd<sup>1</sup>**
8. Piedmont Ave & Kensington Rd
- 9. Piedmont Ave & Wembley Rd<sup>1</sup>**
10. Weatherby Rd & Huntley Dr
11. Silver Fox Rd & St Albans Dr
12. Oak Knoll Dr & Argyle Dr
- 13. Gertrude Dr & Kensington Rd<sup>1</sup>**
14. Bellwood Rd & Walker Lee Dr
15. Druid Ln & Silver Fox Rd

## ANAHEIM ISLANDS

16. Yardley St & Harvest Ln
17. Bienville Ave & Antigua St
18. Bienville Ave & Gravier St
19. Guinida Ln & D' Este Dr
20. Antigua St & Guinida Ln
21. Chamberlain Ave & Harle Ave
22. Banta Ave & Endry St
23. Mac St & Syracuse Ave

## COUNTRY CLUB ISLAND

24. Shadow Hill Dr & Wendover Rd

## NORTH TUSTIN

25. Dunnas Rd & Casselle Ave
26. Cottonwood Dr & Tamarisk Dr
27. Deep Well Rd & Cottonwood Dr
28. Kootenay Dr & Oak Ridge Dr
29. Ervin Ln & Winthrope St
30. Howland Way & Arbolada Way
31. Warren Ave & Clarissa Ln
32. Brier Ln & Highcliff Dr
33. Overhill Dr & Deerhaven Dr

## NORTH TUSTIN (CONTINUED)

34. Bimini Dr & Cambera Ln
35. Coronel Rd & Cherry Hill Dr
36. Gigi Dr & Smoke Tree Ln
37. La Loma Dr & Colony Dr/Heathcliff Dr
38. Racquet Hill & Vista Mar
39. Gwen Ave & Rebecca Ln
40. Kenneth Dr & Woodlawn Ave
41. Rainbow Dr & Dean St
42. Bubbling Well Rd & Rainbow Dr

## LAS FLORES

43. Woodsong & Greenvale
44. Meadowood & Greenvale
45. Woodsong & Castletree
46. Woodsong & Wildemere
47. Crestview Dr & Castletree
48. Grassy Knoll Ln & Ledgewood Dr
49. Rolling Ridge & Shea Ridge

## LADERA RANCH

50. Maybeck Ln & Dawnwood
51. Blakemore Dr & Kempton Ln
52. Main St & Reston Way
53. Sterling Glen & Sutherland Dr
54. Tether Moon Ln & Terrastar Ln
55. Blue Spruce Dr & Magnolia Dr
56. Cousteau Ln & La Salle Ln
57. Ranunculus St & Shively Rd
58. Ranunculus St & Langford Ln
59. Merriweather Pl & Celestine Circle
60. Smoke Tree Dr & Scarlet Maple Dr

## RANCHO MISSION VIEJO

61. Danza St & Vivido St

---

<sup>1</sup> Evaluated under AWSC criteria.

## All-Way Stop Control

Engineering studies evaluating the installation of AWSC should consider guidance provided by the CA MUTCD and the OCTM. Language pertaining to the installation of AWSC on minor streets with a 40 mile per hour speed limit were excluded since they do not pertain to any of the study intersections.

Although CA MUTCD AWSC Criterion A and OCTM AWSC Criterion A do not pertain to any of the study intersections, they are included such that references to the subsequent AWSC Criteria (i.e., Criterion B, C, etc.) are consistent with the CA MUTCD and OCTM.

## California Manual on Uniform Traffic Control Devices

Per the CA MUTCD Section 2B.07, the installation of AWSC should be considered if one of the following Criteria are met:

- A. Interim measure prior to the installation of a traffic signal.
- B. Five or more correctable collisions within a twelve-months period.
- C. When all three minimum volume sub-criteria are met:
  1. The vehicular volume entering from the major street approaches (total of both approaches) averages at least 300 vehicles per hour over any eight-hour period,
  2. The combined vehicular, pedestrian, and bicycle volume entering traffic from the minor street approaches (total of both approaches) averages at least 200 units per hour for the same eight-hour period, and
  3. The average delay to minor street vehicular traffic is at least 30 seconds per vehicle during the highest hour.
- D. If both Criteria 1 and 2 are satisfied to 80 percent of the minimum values.

The CA MUTCD Section 2B.07 also recommends the evaluation of the following Optional Criteria:

- A. The need to control left-turn conflicts.
- B. The need to control vehicle/pedestrian conflicts near locations that generate high pedestrian volumes.
- C. Locations where a road user, after stopping, cannot see conflicting traffic and is not able to negotiate the intersection unless conflicting cross traffic is also required to stop; and
- D. An intersection of two neighborhood collector streets of similar design and operating characteristics where AWSC would improve traffic operational characteristics.

## Orange County Traffic Manual

Per the OCTM, the installation of AWSC should be considered if one of the following Criteria are met:

- A. Interim measure prior to the installation of a traffic signal.
- B. Five or more correctable collisions within a twelve-months period.
- C. When all three minimum volume sub-criteria are met:
  1. Intersection volume is at least 500 vehicles per hour over any eight-hour period,
  2. The combined vehicle and pedestrian volume of the entering traffic on the minor street is at least 40% of the total intersection volume, and
  3. The average minor street delay is at least 30 seconds during the highest hour.

## Engineering Study

The following three intersections in Rossmoor were evaluated for the installation of AWSC:

7. Shakespeare Dr & Wembley Rd – Adjacent to Lee Elementary School
9. Piedmont Ave & Wembley Rd – Adjacent to Jack L. Weaver Elementary School
13. Gertude Dr & Kensington Rd – Adjacent to Francis Hopkinson Elementary School

### TRAFFIC COLLISIONS

Collision data from the Statewide Integrated Traffic Records System (SWITRS), for the seven-year period between 2017 and 2023, was used to evaluate traffic collisions at the study intersections proposed for AWSC; a list of collisions is provided in **Attachment B**. None of the three intersections satisfy the collision threshold of five or more correctable collisions within a twelve-month period (CA MUTCD AWSC Criterion B, OCTM AWSC Criterion B), as shown in **Table 1**.

### TRAFFIC VOLUME

The intersections were also evaluated using the minimum volume threshold. None of the three intersections satisfy the minimum eight-hour period volume threshold (CA MUTCD AWSC Criterion C, OCTM AWSC Criterion C, or the combined criterion of 80 percent of both the collision threshold and minimum eight-hour period volume threshold (CA MUTCD AWSC Criterion D), as shown in **Table 1**.

However, the installation of AWSC at the three intersections adjacent to local elementary schools satisfies CA MUTCD AWSC Optional Criterion B – “The need to control vehicle/pedestrian conflicts near locations that generate high pedestrian volumes.” Each of the study intersections is located immediately adjacent to an elementary school and serves as a primary crossing point for students and families during school arrival and dismissal periods.

Observed pedestrian volumes at these locations, shown in **Table 1**, are well over 100 pedestrians per day, with peak hour pedestrian volumes ranging from 37 to 105 pedestrians per hour. These volumes represent significant and recurring pedestrian activity that coincides with concentrated periods of vehicular traffic, including school-related drop-off and pick-up activity. According to the OCTM School Safety Controls guidance, high pedestrian activity is defined as 25 or more pedestrians per hour. This threshold is met at all three intersections.

The high pedestrian demand, coupled with the presence of young and potentially vulnerable pedestrians, underscores the need for enhanced traffic control to minimize potential conflicts and improve safety for all users. The installation of AWSC will:

- Improve pedestrian safety and right-of-way clarity at these crossings.
- Encourage lower vehicular speeds and improved driver yielding behavior.
- Provide a consistent, predictable environment that supports safe access to and from school grounds.

Based on the observed pedestrian activity and the context of school-adjacent environments, these intersections satisfies CA MUTCD AWSC Optional Criterion B.

Table 1. All-Way Stop Control Study

| Intersection              |                             | MUTCD Criteria B<br>OCTM Criteria B<br>(MUTCD Criteria D)  | MUTCD Criteria C<br>OCTM Criteria C<br>(MUTCD Criteria D) | MUTCD Optional<br>Criteria B      |
|---------------------------|-----------------------------|--|---|-----------------------------------|
|                           |                             | Correctable<br>Collisions Within<br>12-Months <sup>1</sup> | Peak 8-Hour<br>Intersection<br>Volume <sup>2</sup>        | Peak Hour<br>Pedestrian<br>Volume |
| <i>Minimum Thresholds</i> |                             | $\geq 5$ ( $\geq 4$ )                                      | $\geq 4,000$ ( $\geq 3,200$ )                             | $\geq 25$                         |
| 7                         | Shakespeare Dr & Wembley Rd | 0  | 818   | <b>37</b>                         |
| 9                         | Piedmont Ave & Wembley Rd   | 0  | 1,133   | <b>105</b>                        |
| 13                        | Gertude Dr & Kensington Rd  | 0  | 1,225   | <b>78</b>                         |

Notes:

1. Maximum number of correctable collisions reported in twelve-month period between 2017 – 2023.
2. The minimum intersection volume (includes vehicles, pedestrians, and bicycles) for an eight-hour period is 4,000 per CA MUTCD AWSC Criterion C and OCTM AWSC Criterion C and 3,200 per CA MUTCD AWSC Criterion D.
3. **Bold text** indicates the minimum threshold is met.

Source: SWITRS (2017-2023). Fehr & Peers.

## Side-Street Stop Control

Engineering studies evaluating the installation of SSSC should consider guidance provided by the CA MUTCD and the OCTM.

Although CA MUTCD SSSC Criterion A and OCTM SSSC Criterion A do not pertain to any of the study intersections, they are included such that references to the subsequent SSSC Criteria (i.e., Criterion B, C, etc.) are consistent with the CA MUTCD and OCTM.

### California Manual on Uniform Traffic Control Devices (CA MUTCD)

Per the CA MUTCD Section 2B.06, the installation of SSSC should be considered if one of the following Criteria are met:

- A. The vehicular traffic on the major street exceeds 6,000 vehicles per day.
- B. A restricted view exists that requires road users to stop in order to adequately observe conflicting traffic.
- C. Three or more correctable collisions within a twelve-months period, or five or more correctable collisions within a two-year period.

### Orange County Traffic Manual (OCTM)

Per the OCTM, the installation of SSSC should be considered if one of the following Criteria are met:

- A. At a minor street intersecting a designated through highway.
- B. Two or more correctable collisions within a twelve-months period.
- C. Where the critical approach speed is less than 10 miles per hour (mph) on the minor street and:

1. The average hourly volume over a 16-hour period is at least 50 vehicles per hour on the major street; **OR**
  2. Approach volumes on the two intersecting streets are nearly equal and at least 25 vehicles per hour enter the intersection from each of the two intersecting roadways during any 16-hour period.
- D. Where the critical approach speed is between 10 and 15 mph and the average hourly volume over a 16-hour period on the major street is at least 100 vehicles per hour.

The critical approach speed refers to the maximum speed at which a vehicle can approach an intersection while still being able to safely navigate through the intersection. Motorist typically slow down to some extent on approaches at uncontrolled intersections.

## Engineering Study

Fifty-eight (58) intersections were evaluated for the installation of SSSC – all of which are four-legged intersections located in residential neighborhoods. Observed behavior in the field reflected critical approach speeds of 10 mph or less, given the context of residential-adjacent environments and the absence of priority control. Drivers often approached these uncontrolled intersections with increased caution, expecting potential cross-traffic or pedestrian activity, especially when sight was limited due to parked cars. Based on the observed behavior in the field, a critical approach speed of 10 mph was applied at all 58 intersections. As such OCTM SSSC Criterion D was not applied to any of the SSSC.

## TRAFFIC COLLISIONS

Collision data from the Statewide Integrated Traffic Records System (SWITRS), for the seven-year period between 2017 and 2023, was used to evaluate traffic collisions at the study intersections proposed for SSSC; a list of collisions is provided in **Attachment B**.

None of the intersections satisfy the collision threshold of three or more correctable collisions within a twelve-month period, or five or more correctable collisions within a two-year period (CA MUTCD SSSC Criterion C). Applying the collision threshold of two or more correctable collisions within a twelve-month period, the following intersection satisfies OCTM SSSC Criterion B:

### 22. Banta Ave & Endry St

Since the average collision rate in Orange County has historically been lower than the California state average, it is reasonable to lower the threshold from two to one correctable collision within a twelve-month period. This adjustment takes a more proactive approach to traffic safety. As shown in **Table 2**, the following intersections satisfy OCTM SSSC Criterion B – Modified:

1. Quail Run Rd & Donnis Rd
2. Donnie Ann Rd & Donnis Rd
3. Kensington Rd & Chesney Dr
5. Chesney Dr & Loch Lomond Rd
11. Silver Fox Rd & St Albans Dr
17. Bienville Ave & Antigua St
20. Antigua St & Guinida Ln
22. Banta Ave & Endry St

## TRAFFIC VOLUME

The fifty-eight (58) intersections were also evaluated using the minimum volume thresholds (OCTM SSSC Criterion C1 and C2). Major and minor streets were identified based on functional classification, traffic volumes, and geometric characteristics, such as the presence of dips, bumps, etc. Turning movement volumes were totaled by approach and compared with minimum volume thresholds.

As shown in **Table 2**, the following twelve intersections satisfy OCTM SSSC Criterion C1 (the average hourly volume over a 16-hour period is at least 50 vehicles per hour on the major street).

2. Donnie Ann Rd & Donnis Rd
10. Weatherby Rd & Huntley Dr
16. Yardley St & Harvest Ln
19. Guinida Ln & D'Este Dr
22. Banta Ave & Endry St
31. Warren Ave & Clarissa Ln
37. La Loma Dr & Colony Dr/Heathcliff Dr
40. Kenneth Dr & Woodlawn Ave
48. Grassy Knoll Ln & Ledgewood Dr
50. Maybeck Ln & Dawnwood
52. Main St & Reston Way
57. Ranunculus St & Shively Rd

As shown in **Table 2**, the following two intersections satisfy OCTM SSSC Criterion C2 (the hourly volume is at least 25 vehicles for at least 16-hours over a 24-hour period on both streets and the approach volumes are nearly equal).

20. Antigua St & Guinida Ln
22. Banta Ave & Endry St

Although the hourly volume threshold is also met for both streets at Maybeck Ln & Dawnwood (Intersection 50), the approach volumes on the major street is more than double the approach volume on the minor street. Since the approach volumes are not nearly equal, OCTM SSSC Criterion C2 is not satisfied at Maybeck Ln & Dawnwood (Intersection 50).

Table 2. Side-Street Stop Control Study

| Intersection<br>(Major Street & Minor Street) |                                | 16-Hour Volume<br>(vehicles) |          | OCTM Criteria B<br>Modified                                | OCTM Criteria C1                   | OCTM Criteria C2                   |          |
|---|--------------------------------|------------------------------|----------|--|------------------------------------|------------------------------------|----------|
|   |                                |                              |          | Correctable<br>Collisions Within<br>12-Months <sup>1</sup> | Average Hourly Volume <sup>2</sup> | Average Hourly Volume <sup>3</sup> |          |
|   |                                | Major St                     | Minor St |  |                                    | Major Street                       | Major St |
| Minimum Thresholds                            |                                | -                            | -        | ≥ 1  | ≥ 50                               | ≥ 25                               | ≥ 25     |
| 1   | Quail Run Rd & Donnis Rd       | 732                          | 265      | 1  | 46                                 | 46                                 | 17       |
| 2   | Donnie Ann Rd & Donnis Rd      | 823                          | 321      | 1  | 51                                 | 51                                 | 20       |
| 3   | Kensington Rd & Chesney Dr     | 416                          | 185      | 1  | 26                                 | 26                                 | 12       |
| 4   | Wembley Rd & Chesney Dr        | 374                          | 222      | -  | 23                                 | 23                                 | 14       |
| 5   | Chesney Dr & Loch Lomond Rd    | 312                          | 246      | 1  | 20                                 | 20                                 | 15       |
| 6   | Shakespeare Dr & Kensington Rd | 517                          | 271      | -  | 32                                 | 32                                 | 17       |
| 8   | Piedmont Ave & Kensington Rd   | 481                          | 187      | -  | 30                                 | 30                                 | 12       |
| 10  | Weatherby Rd & Huntley Dr      | 1837                         | 248      | -  | 115                                | 115                                | 16       |
| 11  | Silver Fox Rd & St Albans Dr   | 531                          | 221      | 1  | 33                                 | 33                                 | 14       |
| 12  | Oak Knoll Dr & Argyle Dr       | 347                          | 223      | -  | 22                                 | 22                                 | 14       |
| 14  | Bellwood Rd & Walker Lee Dr    | 180                          | 106      | -  | 11                                 | 11                                 | 7        |
| 15  | Druid Ln & Silver Fox Rd       | 688                          | 159      | -  | 43                                 | 43                                 | 10       |
| 16  | Yardley St & Harvest Ln        | 937                          | 290      | -  | 59                                 | 59                                 | 18       |
| 17  | Bienville Ave & Antigua St     | 746                          | 230      | 1  | 47                                 | 47                                 | 14       |
| 18  | Bienville Ave & Gravier St     | 457                          | 209      | -  | 29                                 | 29                                 | 13       |
| 19  | Guinida Ln & D' Este Dr        | 788                          | 178      | -  | 50                                 | 50                                 | 11       |
| 20  | Antigua St & Guinida Ln        | 594                          | 405      | 1  | 37                                 | 37                                 | 25       |

Table 2. Side-Street Stop Control Study

| Intersection<br>(Major Street & Minor Street) |                                      | 16-Hour Volume<br>(vehicles) |          | OCTM Criteria B<br>Modified                                | OCTM Criteria C1                   | OCTM Criteria C2                   |           |
|---|--------------------------------------|------------------------------|----------|--|------------------------------------|------------------------------------|-----------|
|   |                                      |                              |          | Correctable<br>Collisions Within<br>12-Months <sup>1</sup> | Average Hourly Volume <sup>2</sup> | Average Hourly Volume <sup>3</sup> |           |
|   |                                      | Major St                     | Minor St |  |                                    | Major Street                       | Major St  |
| <i>Minimum Thresholds</i>                     |                                      | -                            | -        | ≥ 1  | ≥ 50                               | ≥ 25                               | ≥ 25      |
| 21  | Chamberlain Ave & Harle Ave          | 435                          | 151      | -  | 27                                 | 27                                 | 9         |
| 22  | Banta Ave & Endry St                 | 812                          | 677      | <b>2</b>   | <b>51</b>                          | <b>51</b>                          | <b>42</b> |
| 23  | Mac St & Syracuse Ave                | 346                          | 245      | -  | 22                                 | 22                                 | 15        |
| 24  | Shadow Hill Dr & Wendover Rd         | 396                          | 195      | -  | 25                                 | 25                                 | 12        |
| 25  | Dunnas Rd & Casselle Ave             | 275                          | 201      | -  | 17                                 | 17                                 | 13        |
| 26  | Cottonwood Dr & Tamarisk Dr          | 617                          | 119      | -  | 39                                 | 39                                 | 7         |
| 27  | Deep Well Rd & Cottonwood Dr         | 251                          | 305      | -  | 16                                 | 16                                 | 19        |
| 28  | Kootenay Dr & Oak Ridge Dr           | 560                          | 121      | -  | 35                                 | 35                                 | 8         |
| 29  | Ervin Ln & Winthrope St              | 535                          | 276      | -  | 33                                 | 33                                 | 17        |
| 30  | Howland Way & Arbolada Way           | 247                          | 104      | -  | 15                                 | 15                                 | 7         |
| 31  | Warren Ave & Clarissa Ln             | 1605                         | 197      | -  | <b>100</b>                         | 100                                | 12        |
| 32  | Brier Ln & Highcliff Dr              | 375                          | 181      | -  | 23                                 | 23                                 | 11        |
| 33  | Overhill Dr & Deerhaven Dr           | 195                          | 145      | -  | 12                                 | 12                                 | 9         |
| 34  | Bimini Dr & Cambera Ln               | 353                          | 168      | -  | 22                                 | 22                                 | 11        |
| 35  | Coronel Rd & Cherry Hill Dr          | 700                          | 127      | -  | 44                                 | 44                                 | 8         |
| 36  | Gigi Dr & Smoke Tree Ln              | 378                          | 149      | -  | 24                                 | 24                                 | 9         |
| 37  | La Loma Dr & Colony Dr/Heathcliff Dr | 1941                         | 376      | -  | <b>121</b>                         | 121                                | 24        |
| 38  | Racquet Hill & Vista Mar             | 555                          | 96       | -  | 35                                 | 35                                 | 6         |

Table 2. Side-Street Stop Control Study

| Intersection<br>(Major Street & Minor Street) |                                | 16-Hour Volume<br>(vehicles) |          | OCTM Criteria B<br>Modified                                | OCTM Criteria C1                   | OCTM Criteria C2                   |           |
|---|--------------------------------|------------------------------|----------|--|------------------------------------|------------------------------------|-----------|
|   |                                |                              |          | Correctable<br>Collisions Within<br>12-Months <sup>1</sup> | Average Hourly Volume <sup>2</sup> | Average Hourly Volume <sup>3</sup> |           |
|   |                                | Major St                     | Minor St |  |                                    | Major Street                       | Major St  |
| <i>Minimum Thresholds</i>                     |                                | -                            | -        | $\geq 1$   | $\geq 50$                          | $\geq 25$                          | $\geq 25$ |
| 39  | Gwen Ave & Rebecca Ln          | 151                          | 113      | -  | 9                                  | 9                                  | 7         |
| 40  | Kenneth Dr & Woodlawn Ave      | 857                          | 207      | -  | <b>54</b>                          | 54                                 | 13        |
| 41  | Rainbow Dr & Dean St           | 353                          | 114      | -  | 22                                 | 22                                 | 7         |
| 42  | Bubbling Well Rd & Rainbow Dr  | 312                          | 237      | -  | 20                                 | 20                                 | 15        |
| 43  | Woodsong & Greenvale           | 295                          | 158      | -  | 18                                 | 18                                 | 10        |
| 44  | Meadowood & Greenvale          | 98                           | 85       | -  | 6                                  | 6                                  | 5         |
| 45  | Woodsong & Castletree          | 724                          | 200      | -  | 45                                 | 45                                 | 13        |
| 46  | Woodsong & Wildemere           | 413                          | 257      | -  | 26                                 | 26                                 | 16        |
| 47  | Crestview Dr & Castletree      | 457                          | 218      | -  | 29                                 | 29                                 | 14        |
| 48  | Grassy Knoll Ln & Ledgewood Dr | 1,048                        | 287      | -  | <b>66</b>                          | 66                                 | 18        |
| 49  | Rolling Ridge & Shea Ridge     | 484                          | 253      | -  | 30                                 | 30                                 | 16        |
| 50  | Maybeck Ln & Dawnwood          | 1,069                        | 526      | -  | <b>67</b>                          | 67                                 | 33        |
| 51  | Blakemore Dr & Kempton Ln      | 529                          | 294      | -  | 33                                 | 33                                 | 18        |
| 52  | Main St & Reston Way           | 1,070                        | 324      | -  | <b>67</b>                          | 67                                 | 20        |
| 53  | Sterling Glen & Sutherland Dr  | 363                          | 139      | -  | 23                                 | 23                                 | 9         |
| 54  | Tether Moon Ln & Terrastar Ln  | 377                          | 322      | -  | 24                                 | 24                                 | 20        |
| 55  | Blue Spruce Dr & Magnolia Dr   | 388                          | 111      | -  | 24                                 | 24                                 | 7         |
| 56  | Cousteau Ln & La Salle Ln      | 463                          | 219      | -  | 29                                 | 29                                 | 14        |

Table 2. Side-Street Stop Control Study

| Intersection<br>(Major Street & Minor Street) |                                    | 16-Hour Volume<br>(vehicles) |          | OCTM Criteria B<br>Modified                                | OCTM Criteria C1                   | OCTM Criteria C2                   |           |
|---|------------------------------------|------------------------------|----------|--|------------------------------------|------------------------------------|-----------|
|   |                                    |                              |          | Correctable<br>Collisions Within<br>12-Months <sup>1</sup> | Average Hourly Volume <sup>2</sup> | Average Hourly Volume <sup>3</sup> |           |
|   |                                    | Major St                     | Minor St |  |                                    | Major Street                       | Major St  |
| <i>Minimum Thresholds</i>                     |                                    | -                            | -        | $\geq 1$   | $\geq 50$                          | $\geq 25$                          | $\geq 25$ |
| 57  | Ranunculus St & Shively Rd         | 947                          | 207      | -  | <b>59</b>                          | 59                                 | 13        |
| 58  | Ranunculus St & Langford Ln        | 434                          | 359      | -  | 27                                 | 27                                 | 22        |
| 59  | Merriweather Pl & Celestine Circle | 328                          | 328      | -  | 21                                 | 21                                 | 21        |
| 60  | Smoke Tree Dr & Scarlet Maple Dr   | 637                          | 208      | -  | 40                                 | 40                                 | 13        |
| 61  | Danza St & Vivido St               | 421                          | 222      | -  | 26                                 | 26                                 | 14        |

## Notes:

1. Maximum number of correctable collisions reported in twelve-month period between 2017 – 2023.
2. OCTM SSSC Criterion C1: The average hourly volume over a 16-hour period is at least 50 vehicles per hour on the major street.
3. OCTM SSSC Criterion C2: The hourly volume is at least 25 vehicles for at least 16-hours over a 24-hour period on both streets and the approach volumes are nearly equal.
4. **Bold text** indicates the minimum thresholds are met. **Highlighted rows** indicate that one or more SSSC criteria have been met.

Source: Fehr &amp; Peers.

## Summary & Conclusion

Fehr & Peers completed a stop sign warrant study following guidance from the *California Manual on Uniform Traffic Control Devices* (CA MUTCD, 2014 Revision 9, 2025) and the *Orange County Traffic Manual* (OCTM, 2007).

Installation of AWSC at the three (3) intersections (Intersections 7, 9, and 13) adjacent to local elementary schools satisfies CA MUTCD AWSC Optional Criterion B – “The need to control vehicle/pedestrian conflicts near locations that generate high pedestrian volumes.” The high pedestrian demand, coupled with the presence of young and potentially vulnerable pedestrians, underscores the need for enhanced traffic control to minimize potential conflicts and improve safety for all users. The installation of AWSC will:

- Improve pedestrian safety and right-of-way clarity at these crossings.
- Encourage lower vehicular speeds and improved driver yielding behavior.
- Provide a consistent, predictable environment that supports safe access to and from school grounds.

Installation of SSSC was evaluated at fifty-eight (58) locations and is recommended at eighteen (18) intersections, as summarized in **Table 3**. Please note that intersection sight distance was not evaluated as a part of this study.

Table 3. Stop Sign Warrant Study Summary

|    | Intersection<br>(Major Street & Minor Street) | AWSC<br>MUTCD<br>Optional<br>Criteria B | SSSC OCTM Criteria |                 |    |    |
|----|---|---|--------------------|-----------------|----|----|
|    |   |   | B                  | B –<br>Modified | C1 | C2 |
| 1  | Quail Run Rd & Donnis Rd                      |   |                    | X               |    |    |
| 2  | Donnie Ann Rd & Donnis Rd                     |   |                    | X               | X  |    |
| 3  | Kensington Rd & Chesney Dr                    |   |                    | X               |    |    |
| 4  | Wembley Rd & Chesney Dr                       |   |                    |                 |    |    |
| 5  | Chesney Dr & Loch Lomond Rd                   |   |                    | X               |    |    |
| 6  | Shakespeare Dr & Kensington Rd                |   |                    |                 |    |    |
| 7  | Shakespeare Dr & Wembley Rd                   | X                                       |                    |                 |    |    |
| 8  | Piedmont Ave & Kensington Rd                  |   |                    |                 |    |    |
| 9  | Piedmont Ave & Wembley Rd                     | X                                       |                    |                 |    |    |
| 10 | Weatherby Rd & Huntley Dr                     |   |                    |                 | X  |    |
| 11 | Silver Fox Rd & St Albans Dr                  |   |                    | X               |    |    |
| 12 | Oak Knoll Dr & Argyle Dr                      |   |                    |                 |    |    |
| 13 | Gertude Dr & Kensington Rd                    | X                                       |                    |                 |    |    |
| 14 | Bellwood Rd & Walker Lee Dr                   |   |                    |                 |    |    |
| 15 | Druid Ln & Silver Fox Rd                      |   |                    |                 |    |    |
| 16 | Yardley St & Harvest Ln                       |   |                    |                 | X  |    |
| 17 | Bienville Ave & Antigua St                    |   |                    | X               |    |    |
| 18 | Bienville Ave & Gravier St                    |   |                    |                 |    |    |
| 19 | Guinida Ln & D' Este Dr                       |   |                    |                 | X  |    |
| 20 | Antigua St & Guinida Ln                       |   |                    | X               |    | X  |
| 21 | Chamberlain Ave & Harle Ave                   |   |                    |                 |    |    |
| 22 | Banta Ave & Endry St                          |   | X                  | X               | X  | X  |
| 23 | Mac St & Syracuse Ave                         |   |                    |                 |    |    |
| 24 | Shadow Hill Dr & Wendover Rd                  |   |                    |                 |    |    |
| 25 | Dunnas Rd & Casselle Ave                      |   |                    |                 |    |    |
| 26 | Cottonwood Dr & Tamarisk Dr                   |   |                    |                 |    |    |
| 27 | Deep Well Rd & Cottonwood Dr                  |   |                    |                 |    |    |
| 28 | Kootenay Dr & Oak Ridge Dr                    |   |                    |                 |    |    |
| 29 | Ervin Ln & Winthrope St                       |   |                    |                 |    |    |
| 30 | Howland Way & Arbolada Way                    |   |                    |                 |    |    |
| 31 | Warren Ave & Clarissa Ln                      |   |                    |                 | X  |    |

|           | Intersection<br>(Major Street & Minor Street)   | AWSC<br>MUTCD<br>Optional<br>Criteria B | SSSC OCTM Criteria |                 |    |    |
|-----------|---|---|--------------------|-----------------|----|----|
|           |   |   | B                  | B -<br>Modified | C1 | C2 |
| 32        | Brier Ln & Highcliff Dr                         |   |                    |                 |    |    |
| 33        | Overhill Dr & Deerhaven Dr                      |   |                    |                 |    |    |
| 34        | Bimini Dr & Cambera Ln                          |   |                    |                 |    |    |
| 35        | Coronel Rd & Cherry Hill Dr                     |   |                    |                 |    |    |
| 36        | Gigi Dr & Smoke Tree Ln                         |   |                    |                 |    |    |
| <b>37</b> | <b>La Loma Dr &amp; Colony Dr/Heathcliff Dr</b> |   |                    |                 | X  |    |
| 38        | Racquet Hill & Vista Mar                        |   |                    |                 |    |    |
| 39        | Gwen Ave & Rebecca Ln                           |   |                    |                 |    |    |
| <b>40</b> | <b>Kenneth Dr &amp; Woodlawn Ave</b>            |   |                    |                 | X  |    |
| 41        | Rainbow Dr & Dean St                            |   |                    |                 |    |    |
| 42        | Bubbling Well Rd & Rainbow Dr                   |   |                    |                 |    |    |
| 43        | Woodsong & Greenvale                            |   |                    |                 |    |    |
| 44        | Meadowood & Greenvale                           |   |                    |                 |    |    |
| 45        | Woodsong & Castletree                           |   |                    |                 |    |    |
| 46        | Woodsong & Wildemere                            |   |                    |                 |    |    |
| 47        | Crestview Dr & Castletree                       |   |                    |                 |    |    |
| <b>48</b> | <b>Grassy Knoll Ln &amp; Ledgewood Dr</b>       |   |                    |                 | X  |    |
| 49        | Rolling Ridge & Shea Ridge                      |   |                    |                 |    |    |
| <b>50</b> | <b>Maybeck Ln &amp; Dawnwood</b>                |   |                    |                 | X  |    |
| 51        | Blakemore Dr & Kempton Ln                       |   |                    |                 |    |    |
| <b>52</b> | <b>Main St &amp; Reston Way</b>                 |   |                    |                 | X  |    |
| 53        | Sterling Glen & Sutherland Dr                   |   |                    |                 |    |    |
| 54        | Tether Moon Ln & Terrastar Ln                   |   |                    |                 |    |    |
| 55        | Blue Spruce Dr & Magnolia Dr                    |   |                    |                 |    |    |
| 56        | Cousteau Ln & La Salle Ln                       |   |                    |                 |    |    |
| <b>57</b> | <b>Ranunculus St &amp; Shively Rd</b>           |   |                    |                 | X  |    |
| 58        | Ranunculus St & Langford Ln                     |   |                    |                 |    |    |
| 59        | Merriweather Pl & Celestine Circle              |   |                    |                 |    |    |
| 60        | Smoke Tree Dr & Scarlet Maple Dr                |   |                    |                 |    |    |
| 61        | Danza St & Vivido St                            |   |                    |                 |    |    |

Note: **Highlighted rows with bold text** indicate that one or more AWSC or SSSC criteria have been met.  
Source: Fehr & Peers.

The final list of locations recommended for stop sign installation is provided below. Intersections are listed as "Major Street & Minor Street", with bold text indicated the approach(es) proposed for stop-control.

**ROSSMOOR**

1. Quail Run Rd & **Donnis Rd**
2. Donnie Ann Rd & **Donnis Rd**
3. Kensington Rd & **Chesney Dr**
4. Chesney Dr & **Loch Lomond Rd**
5. **Shakespeare Dr & Wembley Rd<sup>2</sup>**
6. **Piedmont Ave & Wembley Rd<sup>2</sup>**
7. Weatherby Rd & **Huntley Dr**
8. Silver Fox Rd & **St Albans Dr**
9. **Gertrude Dr & Kensington Rd<sup>2</sup>**

**ANAHEIM ISLANDS**

10. Yardley St & **Harvest Ln**
11. Bienville Ave & **Antigua St**
12. Guinida Ln & **D' Este Dr**
13. Antigua St & **Guinida Ln**
14. Banta Ave & **Endry St**

**NORTH TUSTIN**

15. Warren Ave & **Clarissa Ln**
16. La Loma Dr & **Colony Dr/Heathcliff Dr**
17. Kenneth Dr & **Woodlawn Ave**

**LAS FLORES**

18. Grassy Knoll Ln & **Ledgewood Dr**

**LADERA RANCH**

19. Maybeck Ln & **Dawnwood**
20. Main St & **Reston Way**
21. Ranunculus St & **Shively Rd**

---

## Attachments

Attachment A – Traffic Counts

Attachment B – Collision Records

---

<sup>2</sup> AWSC proposed.

# Attachment A – Traffic Counts

LOCATION: Antigua St -- Bienville Ave  
 CITY/STATE: Orange, CA

QC JOB #: 16966403  
 DATE: Wed, Apr 9 2025

Peak-Hour: 7:25 AM -- 8:25 AM  
 Peak 15-Min: 7:40 AM -- 7:55 AM

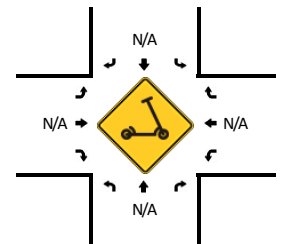
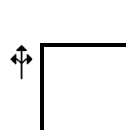
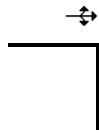
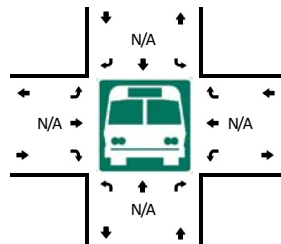
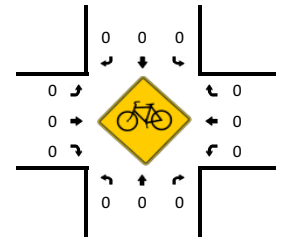
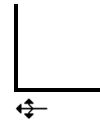
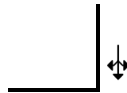
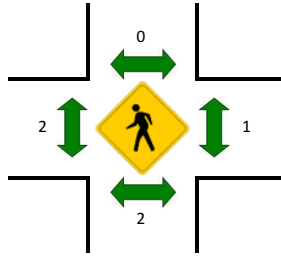
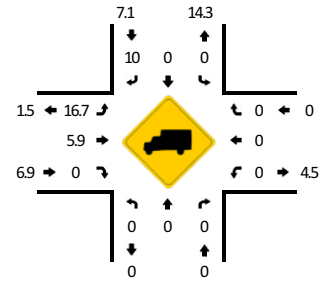
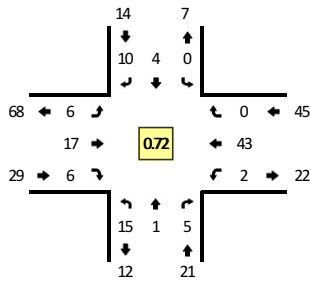

| 5-Min Count Period Beginning At | Antigua St (Northbound) |      |       |   | Antigua St (Southbound) |      |       |   | Bienville Ave (Eastbound) |      |       |   | Bienville Ave (Westbound) |      |       |   | Total | Hourly Totals |
|---------------------------------|-------------------------|------|-------|---|-------------------------|------|-------|---|---------------------------|------|-------|---|---------------------------|------|-------|---|-------|---------------|
|                                 | Left                    | Thru | Right | U | Left                    | Thru | Right | U | Left                      | Thru | Right | U | Left                      | Thru | Right | U |       |               |
| 6:00 AM                         | 1                       | 0    | 0     | 0 | 0                       | 0    | 0     | 0 | 0                         | 0    | 0     | 0 | 0                         | 3    | 0     | 0 | 4     |               |
| 6:05 AM                         | 2                       | 0    | 0     | 0 | 0                       | 0    | 0     | 0 | 0                         | 1    | 0     | 0 | 0                         | 2    | 0     | 0 | 5     |               |
| 6:10 AM                         | 1                       | 0    | 0     | 0 | 0                       | 0    | 0     | 0 | 0                         | 0    | 0     | 0 | 0                         | 1    | 0     | 0 | 2     |               |
| 6:15 AM                         | 0                       | 0    | 0     | 0 | 0                       | 0    | 0     | 0 | 0                         | 0    | 0     | 1 | 0                         | 2    | 0     | 0 | 3     |               |
| 6:20 AM                         | 0                       | 0    | 0     | 0 | 0                       | 0    | 0     | 0 | 0                         | 0    | 0     | 1 | 0                         | 3    | 0     | 0 | 4     |               |
| 6:25 AM                         | 0                       | 0    | 0     | 0 | 0                       | 0    | 1     | 0 | 0                         | 0    | 2     | 0 | 0                         | 1    | 0     | 0 | 4     |               |
| 6:30 AM                         | 2                       | 1    | 0     | 0 | 0                       | 0    | 0     | 0 | 0                         | 0    | 1     | 0 | 0                         | 1    | 0     | 0 | 5     |               |
| 6:35 AM                         | 2                       | 0    | 0     | 0 | 0                       | 0    | 1     | 0 | 0                         | 0    | 0     | 0 | 0                         | 4    | 0     | 0 | 8     |               |
| 6:40 AM                         | 0                       | 0    | 0     | 0 | 0                       | 0    | 0     | 0 | 0                         | 0    | 0     | 0 | 0                         | 1    | 1     | 0 | 2     |               |
| 6:45 AM                         | 0                       | 0    | 1     | 0 | 0                       | 0    | 2     | 0 | 0                         | 0    | 2     | 0 | 0                         | 2    | 0     | 0 | 7     |               |
| 6:50 AM                         | 1                       | 0    | 0     | 0 | 0                       | 1    | 0     | 0 | 0                         | 0    | 2     | 0 | 0                         | 7    | 0     | 0 | 11    |               |
| 6:55 AM                         | 1                       | 0    | 0     | 0 | 0                       | 0    | 0     | 0 | 0                         | 0    | 0     | 0 | 0                         | 3    | 0     | 0 | 4     | 59            |
| 7:00 AM                         | 0                       | 0    | 0     | 0 | 0                       | 1    | 1     | 0 | 0                         | 0    | 0     | 0 | 0                         | 0    | 0     | 0 | 2     | 57            |
| 7:05 AM                         | 1                       | 0    | 0     | 0 | 0                       | 0    | 1     | 0 | 0                         | 0    | 1     | 0 | 0                         | 3    | 0     | 0 | 6     | 58            |
| 7:10 AM                         | 0                       | 0    | 0     | 0 | 0                       | 2    | 0     | 0 | 0                         | 0    | 0     | 0 | 0                         | 5    | 0     | 0 | 7     | 63            |
| 7:15 AM                         | 1                       | 0    | 0     | 0 | 1                       | 0    | 0     | 0 | 0                         | 1    | 0     | 1 | 0                         | 0    | 0     | 0 | 5     | 65            |
| 7:20 AM                         | 3                       | 0    | 0     | 0 | 0                       | 0    | 1     | 0 | 0                         | 0    | 0     | 1 | 0                         | 2    | 0     | 0 | 7     | 68            |
| 7:25 AM                         | 2                       | 0    | 1     | 0 | 0                       | 0    | 1     | 0 | 0                         | 0    | 1     | 0 | 0                         | 4    | 0     | 0 | 9     | 73            |
| 7:30 AM                         | 2                       | 0    | 0     | 0 | 0                       | 0    | 1     | 0 | 0                         | 0    | 0     | 0 | 0                         | 0    | 0     | 0 | 3     | 71            |
| 7:35 AM                         | 1                       | 0    | 0     | 0 | 0                       | 1    | 0     | 0 | 0                         | 0    | 0     | 0 | 0                         | 3    | 0     | 0 | 5     | 68            |
| 7:40 AM                         | 2                       | 1    | 1     | 0 | 0                       | 1    | 1     | 0 | 2                         | 0    | 1     | 0 | 1                         | 8    | 0     | 0 | 18    | 84            |
| 7:45 AM                         | 2                       | 0    | 0     | 0 | 0                       | 1    | 2     | 0 | 0                         | 3    | 0     | 0 | 0                         | 5    | 0     | 0 | 13    | 90            |
| 7:50 AM                         | 1                       | 0    | 0     | 0 | 0                       | 1    | 0     | 0 | 0                         | 2    | 1     | 0 | 0                         | 2    | 0     | 0 | 7     | 86            |
| 7:55 AM                         | 1                       | 0    | 0     | 0 | 0                       | 0    | 0     | 0 | 1                         | 2    | 1     | 0 | 1                         | 3    | 0     | 0 | 9     | 91            |
| 8:00 AM                         | 1                       | 0    | 1     | 0 | 0                       | 0    | 3     | 0 | 0                         | 0    | 0     | 0 | 0                         | 2    | 0     | 0 | 7     | 96            |
| 8:05 AM                         | 0                       | 0    | 0     | 0 | 0                       | 0    | 0     | 0 | 0                         | 2    | 0     | 0 | 0                         | 4    | 0     | 0 | 6     | 96            |
| 8:10 AM                         | 0                       | 0    | 2     | 0 | 0                       | 0    | 0     | 0 | 1                         | 2    | 0     | 0 | 0                         | 2    | 0     | 0 | 7     | 96            |
| 8:15 AM                         | 0                       | 0    | 0     | 0 | 0                       | 0    | 1     | 0 | 1                         | 3    | 0     | 0 | 0                         | 7    | 0     | 0 | 12    | 103           |
| 8:20 AM                         | 3                       | 0    | 0     | 0 | 0                       | 0    | 1     | 0 | 1                         | 2    | 3     | 0 | 0                         | 3    | 0     | 0 | 13    | 109           |
| 8:25 AM                         | 1                       | 0    | 0     | 0 | 0                       | 0    | 1     | 0 | 0                         | 1    | 0     | 0 | 0                         | 2    | 0     | 0 | 5     | 105           |
| 8:30 AM                         | 0                       | 0    | 0     | 0 | 0                       | 0    | 0     | 0 | 0                         | 4    | 0     | 0 | 1                         | 1    | 0     | 0 | 6     | 108           |
| 8:35 AM                         | 0                       | 0    | 0     | 0 | 0                       | 0    | 1     | 0 | 0                         | 2    | 0     | 0 | 0                         | 2    | 0     | 0 | 5     | 108           |
| 8:40 AM                         | 0                       | 0    | 1     | 0 | 0                       | 0    | 0     | 0 | 0                         | 1    | 0     | 0 | 0                         | 1    | 0     | 0 | 3     | 93            |
| 8:45 AM                         | 0                       | 0    | 0     | 0 | 0                       | 0    | 0     | 0 | 0                         | 1    | 0     | 0 | 0                         | 3    | 0     | 0 | 4     | 84            |
| 8:50 AM                         | 0                       | 0    | 0     | 0 | 0                       | 2    | 0     | 0 | 0                         | 1    | 0     | 0 | 0                         | 2    | 0     | 0 | 5     | 82            |
| 8:55 AM                         | 0                       | 0    | 0     | 0 | 0                       | 0    | 0     | 0 | 0                         | 1    | 0     | 0 | 0                         | 1    | 0     | 0 | 2     | 75            |
| 9:00 AM                         | 0                       | 0    | 0     | 0 | 1                       | 1    | 0     | 0 | 0                         | 1    | 0     | 0 | 0                         | 2    | 0     | 0 | 5     | 73            |
| 9:05 AM                         | 0                       | 0    | 0     | 0 | 0                       | 0    | 0     | 0 | 0                         | 0    | 0     | 0 | 0                         | 4    | 0     | 0 | 4     | 71            |

Attachment B

| 5-Min Count Period Beginning At | Antigua St (Northbound) |      |       |   | Antigua St (Southbound) |      |       |   | Bienville Ave (Eastbound) |      |       |   | Bienville Ave (Westbound) |      |       |   | Total | Hourly Totals |
|---------------------------------|-------------------------|------|-------|---|-------------------------|------|-------|---|---------------------------|------|-------|---|---------------------------|------|-------|---|-------|---------------|
|                                 | Left                    | Thru | Right | U | Left                    | Thru | Right | U | Left                      | Thru | Right | U | Left                      | Thru | Right | U |       |               |
| 9:10 AM                         | 1                       | 0    | 0     | 0 | 0                       | 0    | 0     | 0 | 0                         | 1    | 0     | 0 | 0                         | 0    | 0     | 0 | 2     | 66            |
| 9:15 AM                         | 0                       | 0    | 0     | 0 | 0                       | 0    | 0     | 0 | 0                         | 0    | 0     | 0 | 0                         | 1    | 0     | 0 | 1     | 55            |
| 9:20 AM                         | 1                       | 0    | 0     | 0 | 0                       | 0    | 0     | 0 | 0                         | 0    | 0     | 2 | 0                         | 1    | 1     | 0 | 5     | 47            |
| 9:25 AM                         | 0                       | 0    | 0     | 0 | 0                       | 0    | 0     | 0 | 0                         | 0    | 0     | 0 | 0                         | 0    | 0     | 0 | 0     | 42            |
| 9:30 AM                         | 0                       | 0    | 0     | 0 | 0                       | 0    | 0     | 0 | 0                         | 1    | 0     | 0 | 0                         | 1    | 3     | 0 | 5     | 41            |
| 9:35 AM                         | 1                       | 0    | 0     | 0 | 0                       | 0    | 1     | 0 | 0                         | 0    | 0     | 1 | 0                         | 0    | 0     | 0 | 3     | 39            |
| 9:40 AM                         | 0                       | 0    | 0     | 0 | 0                       | 0    | 0     | 0 | 0                         | 0    | 0     | 0 | 0                         | 0    | 1     | 0 | 1     | 37            |
| 9:45 AM                         | 1                       | 1    | 0     | 0 | 0                       | 0    | 0     | 0 | 0                         | 1    | 0     | 0 | 0                         | 1    | 1     | 0 | 5     | 38            |
| 9:50 AM                         | 0                       | 0    | 0     | 0 | 0                       | 0    | 0     | 0 | 0                         | 0    | 0     | 0 | 0                         | 0    | 1     | 0 | 1     | 34            |
| 9:55 AM                         | 1                       | 0    | 0     | 0 | 0                       | 0    | 0     | 0 | 0                         | 1    | 0     | 0 | 0                         | 1    | 0     | 0 | 3     | 35            |
| 10:00 AM                        | 0                       | 0    | 0     | 0 | 0                       | 0    | 1     | 0 | 1                         | 2    | 0     | 0 | 0                         | 0    | 2     | 0 | 6     | 36            |
| 10:05 AM                        | 1                       | 0    | 0     | 0 | 0                       | 0    | 0     | 0 | 0                         | 0    | 0     | 0 | 0                         | 0    | 0     | 0 | 1     | 33            |
| 10:10 AM                        | 0                       | 0    | 0     | 0 | 0                       | 0    | 1     | 0 | 0                         | 1    | 0     | 0 | 0                         | 0    | 0     | 0 | 2     | 33            |
| 10:15 AM                        | 2                       | 0    | 0     | 0 | 0                       | 0    | 0     | 0 | 0                         | 1    | 0     | 0 | 0                         | 0    | 1     | 0 | 4     | 36            |
| 10:20 AM                        | 0                       | 0    | 1     | 0 | 0                       | 0    | 0     | 0 | 0                         | 1    | 1     | 0 | 2                         | 0    | 0     | 0 | 5     | 36            |
| 10:25 AM                        | 0                       | 0    | 0     | 0 | 0                       | 0    | 1     | 0 | 1                         | 2    | 1     | 0 | 0                         | 4    | 0     | 0 | 9     | 45            |
| 10:30 AM                        | 1                       | 0    | 0     | 0 | 0                       | 0    | 0     | 0 | 0                         | 1    | 0     | 0 | 0                         | 1    | 0     | 0 | 3     | 43            |
| 10:35 AM                        | 2                       | 0    | 0     | 0 | 0                       | 0    | 0     | 0 | 0                         | 0    | 0     | 0 | 0                         | 4    | 0     | 0 | 6     | 46            |
| 10:40 AM                        | 1                       | 0    | 0     | 0 | 0                       | 0    | 0     | 0 | 1                         | 2    | 0     | 0 | 0                         | 0    | 0     | 0 | 4     | 49            |
| 10:45 AM                        | 0                       | 0    | 0     | 0 | 0                       | 0    | 1     | 0 | 0                         | 0    | 0     | 0 | 0                         | 5    | 0     | 0 | 6     | 50            |
| 10:50 AM                        | 0                       | 0    | 0     | 0 | 0                       | 0    | 0     | 0 | 2                         | 1    | 0     | 0 | 0                         | 1    | 0     | 0 | 4     | 53            |
| 10:55 AM                        | 0                       | 0    | 1     | 0 | 0                       | 0    | 0     | 0 | 0                         | 1    | 0     | 0 | 0                         | 1    | 0     | 0 | 3     | 53            |
| 11:00 AM                        | 0                       | 0    | 1     | 0 | 0                       | 0    | 1     | 0 | 0                         | 1    | 0     | 0 | 0                         | 2    | 0     | 0 | 5     | 52            |
| 11:05 AM                        | 0                       | 0    | 1     | 0 | 0                       | 0    | 1     | 0 | 0                         | 1    | 0     | 0 | 0                         | 1    | 0     | 0 | 4     | 55            |
| 11:10 AM                        | 0                       | 0    | 0     | 0 | 0                       | 0    | 0     | 0 | 0                         | 1    | 0     | 0 | 0                         | 0    | 0     | 0 | 1     | 54            |
| 11:15 AM                        | 2                       | 0    | 2     | 0 | 0                       | 0    | 0     | 0 | 0                         | 1    | 0     | 0 | 0                         | 0    | 0     | 0 | 5     | 55            |
| 11:20 AM                        | 0                       | 0    | 0     | 0 | 0                       | 0    | 0     | 0 | 0                         | 3    | 0     | 0 | 0                         | 5    | 0     | 0 | 8     | 58            |
| 11:25 AM                        | 1                       | 0    | 0     | 0 | 0                       | 0    | 0     | 0 | 0                         | 1    | 0     | 0 | 1                         | 0    | 0     | 0 | 3     | 52            |
| 11:30 AM                        | 0                       | 0    | 0     | 0 | 0                       | 0    | 0     | 0 | 0                         | 0    | 0     | 0 | 0                         | 0    | 0     | 0 | 0     | 49            |
| 11:35 AM                        | 0                       | 0    | 0     | 0 | 0                       | 0    | 0     | 0 | 1                         | 0    | 2     | 0 | 0                         | 0    | 0     | 0 | 3     | 46            |
| 11:40 AM                        | 0                       | 0    | 0     | 0 | 0                       | 0    | 0     | 0 | 0                         | 2    | 1     | 0 | 0                         | 1    | 0     | 0 | 4     | 46            |
| 11:45 AM                        | 1                       | 0    | 0     | 0 | 0                       | 0    | 0     | 0 | 0                         | 0    | 1     | 0 | 0                         | 1    | 0     | 0 | 3     | 43            |
| 11:50 AM                        | 0                       | 0    | 1     | 0 | 0                       | 0    | 0     | 0 | 0                         | 3    | 0     | 0 | 0                         | 1    | 0     | 0 | 5     | 44            |
| 11:55 AM                        | 1                       | 0    | 0     | 0 | 0                       | 0    | 0     | 0 | 0                         | 0    | 0     | 0 | 0                         | 2    | 0     | 0 | 3     | 44            |
| 12:00 PM                        | 0                       | 0    | 0     | 0 | 0                       | 0    | 0     | 0 | 0                         | 3    | 0     | 0 | 0                         | 0    | 0     | 0 | 3     | 42            |
| 12:05 PM                        | 1                       | 0    | 1     | 0 | 0                       | 0    | 0     | 0 | 0                         | 0    | 0     | 0 | 0                         | 4    | 0     | 0 | 6     | 44            |
| 12:10 PM                        | 2                       | 0    | 0     | 0 | 0                       | 0    | 0     | 0 | 0                         | 0    | 0     | 0 | 0                         | 4    | 0     | 0 | 6     | 49            |
| 12:15 PM                        | 0                       | 1    | 0     | 0 | 0                       | 0    | 0     | 0 | 0                         | 0    | 0     | 0 | 0                         | 0    | 0     | 0 | 1     | 45            |
| 12:20 PM                        | 0                       | 0    | 0     | 0 | 0                       | 0    | 0     | 0 | 0                         | 0    | 0     | 0 | 0                         | 1    | 0     | 0 | 1     | 38            |
| 12:25 PM                        | 0                       | 0    | 0     | 0 | 0                       | 0    | 0     | 0 | 0                         | 0    | 0     | 0 | 0                         | 0    | 0     | 0 | 0     | 35            |
| 12:30 PM                        | 0                       | 0    | 0     | 0 | 0                       | 0    | 1     | 0 | 0                         | 0    | 0     | 0 | 0                         | 1    | 0     | 0 | 2     | 37            |
| 12:35 PM                        | 0                       | 0    | 0     | 0 | 0                       | 0    | 0     | 0 | 0                         | 1    | 0     | 0 | 0                         | 2    | 0     | 0 | 3     | 37            |
| 12:40 PM                        | 0                       | 0    | 0     | 0 | 0                       | 0    | 0     | 0 | 0                         | 3    | 0     | 0 | 0                         | 2    | 0     | 0 | 5     | 38            |
| 12:45 PM                        | 0                       | 0    | 0     | 0 | 0                       | 0    | 0     | 0 | 0                         | 1    | 0     | 0 | 0                         | 2    | 0     | 0 | 3     | 38            |
| 12:50 PM                        | 1                       | 0    | 0     | 0 | 0                       | 0    | 0     | 0 | 0                         | 4    | 0     | 0 | 0                         | 0    | 0     | 0 | 5     | 38            |
| 12:55 PM                        | 0                       | 1    | 1     | 0 | 0                       | 0    | 1     | 0 | 1                         | 0    | 0     | 0 | 0                         | 0    | 0     | 0 | 4     | 39            |
| 1:00 PM                         | 0                       | 0    | 0     | 0 | 0                       | 0    | 1     | 0 | 0                         | 3    | 0     | 0 | 0                         | 2    | 0     | 0 | 6     | 42            |
| 1:05 PM                         | 0                       | 0    | 1     | 0 | 0                       | 0    | 0     | 0 | 0                         | 0    | 1     | 0 | 0                         | 5    | 0     | 0 | 7     | 43            |
| 1:10 PM                         | 1                       | 0    | 0     | 0 | 0                       | 0    | 0     | 0 | 0                         | 1    | 0     | 0 | 0                         | 1    | 0     | 0 | 3     | 40            |
| 1:15 PM                         | 1                       | 1    | 0     | 0 | 0                       | 0    | 0     | 0 | 1                         | 1    | 0     | 0 | 0                         | 1    | 0     | 0 | 5     | 44            |
| 1:20 PM                         | 0                       | 0    | 0     | 0 | 0                       | 0    | 0     | 0 | 0                         | 5    | 0     | 0 | 1                         | 1    | 0     | 0 | 7     | 50            |
| 1:25 PM                         | 0                       | 0    | 0     | 0 | 0                       | 0    | 0     | 0 | 0                         | 1    | 1     | 0 | 1                         | 0    | 0     | 0 | 3     | 53            |
| 1:30 PM                         | 0                       | 0    | 0     | 0 | 0                       | 0    | 0     | 0 | 1                         | 1    | 0     | 0 | 0                         | 3    | 0     | 0 | 5     | 56            |
| 1:35 PM                         | 0                       | 0    | 1     | 0 | 0                       | 0    | 0     | 0 | 0                         | 2    | 0     | 0 | 0                         | 2    | 0     | 0 | 5     | 58            |
| 1:40 PM                         | 1                       | 0    | 0     | 0 | 0                       | 0    | 2     | 0 | 0                         | 1    | 0     | 0 | 0                         | 0    | 0     | 0 | 4     | 57            |
| 1:45 PM                         | 0                       | 0    | 0     | 0 | 0                       | 0    | 0     | 0 | 0                         | 0    | 1     | 0 | 0                         | 1    | 0     | 0 | 2     | 56            |
| 1:50 PM                         | 0                       | 0    | 0     | 0 | 0                       | 0    | 1     | 0 | 0                         | 2    | 0     | 0 | 0                         | 1    | 0     | 0 | 4     | 55            |
| 1:55 PM                         | 0                       | 1    | 1     | 0 | 0                       | 0    | 0     | 0 | 0                         | 1    | 0     | 0 | 0                         | 3    | 0     | 0 | 6     | 57            |
| 2:00 PM                         | 0                       | 0    | 0     | 0 | 0                       | 0    | 2     | 0 | 0                         | 0    | 0     | 0 | 0                         | 2    | 0     | 0 | 4     | 55            |
| 2:05 PM                         | 0                       | 0    | 0     | 0 | 0                       | 0    | 0     | 0 | 0                         | 0    | 0     | 0 | 1                         | 0    | 0     | 0 | 1     | 49            |
| 2:10 PM                         | 0                       | 0    | 0     | 0 | 0                       | 0    | 1     | 0 | 0                         | 1    | 0     | 0 | 0                         | 0    | 0     | 0 | 2     | 48            |
| 2:15 PM                         | 1                       | 0    | 0     | 0 | 0                       | 0    | 0     | 0 | 0                         | 1    | 0     | 0 | 0                         | 0    | 0     | 0 | 2     | 45            |
| 2:20 PM                         | 0                       | 0    | 0     | 0 | 0                       | 0    | 0     | 0 | 0                         | 0    | 0     | 0 | 0                         | 0    | 0     | 0 | 0     | 38            |
| 2:25 PM                         | 0                       | 0    | 0     | 0 | 0                       | 0    | 0     | 0 | 1                         | 0    | 1     | 0 | 0                         | 1    | 0     | 0 | 3     | 38            |
| 2:30 PM                         | 1                       | 0    | 0     | 0 | 0                       | 0    | 1     | 0 | 0                         | 2    | 1     | 0 | 2                         | 2    | 0     | 0 | 9     | 42            |
| 2:35 PM                         | 3                       | 0    | 0     | 0 | 0                       | 0    | 0     | 0 | 0                         | 0    | 0     | 0 | 0                         | 1    | 0     | 0 | 4     | 41            |
| 2:40 PM                         | 0                       | 0    | 0     | 0 | 0                       | 0    | 0     | 0 | 0                         | 2    | 0     | 0 | 0                         | 2    | 0     | 0 | 4     | 41            |
| 2:45 PM                         | 2                       | 0    | 0     | 0 | 0                       | 0    | 0     | 0 | 1                         | 0    | 1     | 0 | 0                         | 1    | 0     | 0 | 5     | 44            |
| 2:50 PM                         | 1                       | 0    | 0     | 0 | 0                       | 0    | 1     | 0 | 0                         | 1    | 0     | 0 | 0                         | 3    | 0     | 0 | 6     | 46            |
| 2:55 PM                         | 0                       | 0    | 1     | 0 | 0                       | 0    | 0     | 0 | 0                         | 0    | 1     | 0 | 0                         | 2    | 0     | 0 | 4     | 44            |
| 3:00 PM                         | 0                       | 0    | 0     | 0 | 0                       | 0    | 0     | 0 | 0                         | 2    | 0     | 0 | 0                         | 1    | 0     | 0 | 3     | 43            |
| 3:05 PM                         | 0                       | 0    | 1     | 0 | 0                       | 0    | 0     | 0 | 0                         | 0    | 1     | 0 | 0                         | 1    | 0     | 0 | 3     | 45            |
| 3:10 PM                         | 1                       | 0    | 0     | 0 | 0                       | 0    | 0     | 0 | 0                         | 3    | 0     | 0 | 0                         | 2    | 0     | 0 | 6     | 49            |
| 3:15 PM                         | 0                       | 0    | 0     | 0 | 0                       | 0    | 0     | 0 | 1                         | 3    | 2     | 0 | 1                         | 1    | 0     | 0 | 8     | 55            |
| 3:20 PM                         | 0                       | 0    | 1     | 0 | 0                       | 0    | 0     | 0 | 0                         | 2    | 0     | 0 | 0                         | 1    | 0     | 0 | 4     | 59            |
| 3:25 PM                         | 0                       | 0    | 0     | 0 | 0                       | 0    | 0     | 0 | 0                         | 1    | 0     | 0 | 0                         | 0    | 0     | 0 | 1     | 57            |
| 3:30 PM                         | 0                       | 0    | 0     | 0 | 0                       | 0    | 1     | 0 | 0                         | 1    | 0     | 0 | 0                         | 1    | 0     | 0 | 3     | 51            |
| 3:35 PM                         | 1                       | 0    | 0     | 0 | 0                       | 0    | 0     | 0 | 0                         | 1    | 1     | 0 | 0                         | 0    | 0     | 0 | 3     | 50            |
| 3:40 PM                         | 0                       | 0    | 0     | 0 | 0                       | 0    | 0     | 0 | 3                         | 2    | 1     | 0 | 0                         | 3    | 0     | 0 | 9     | 55            |
| 3:45 PM                         | 0                       | 0    | 0     | 0 | 0                       | 0    | 1     | 0 | 1                         | 2    | 1     | 0 | 0                         | 1    | 0     | 0 | 6     | 56            |
| 3:50 PM                         | 0                       | 0    | 0     | 0 | 0                       | 0    | 1     | 0 | 0                         | 3    | 0     | 0 | 0                         | 2    | 0     | 0 | 6     | 56            |
| 3:55 PM                         | 1                       | 0    | 0     | 0 | 0                       | 0    | 1     | 0 | 0                         | 3    | 1     | 0 | 0                         | 3    | 0     | 0 | 9     | 61            |
| 4:00 PM                         | 0                       | 0    | 0     | 0 | 0                       | 0    | 0     | 0 | 2                         | 3    | 0     | 0 | 1                         | 0    | 0     | 0 | 6     | 64            |
| 4:05 PM                         | 1                       | 0    | 0     | 0 | 0                       | 0    | 2     | 0 | 2                         | 1    | 0     | 0 | 0                         | 2    | 0     | 0 | 8     | 69            |
| 4:10 PM                         | 1                       | 0    | 0     | 0 | 0                       | 0    | 0     | 0 | 1                         | 4    | 0     | 0 | 0                         | 4    | 0     | 0 | 10    | 73            |
| 4:15 PM                         | 0                       | 0    | 0     | 0 | 0                       | 1    | 0     | 0 | 1                         | 2    | 0     | 0 | 0                         | 1    | 0     | 0 | 5     | 70            |
| 4:20 PM                         | 0                       | 0    | 0     | 0 | 0                       | 0    | 0     | 0 | 1                         | 1    | 2     | 0 | 0                         | 2    | 0     | 0 | 6     | 72            |
| 4:25 PM                         | 1                       | 0    | 1     | 0 | 0                       | 0    | 0     | 0 | 0                         | 3    | 1     | 0 | 0                         | 1    | 0     | 0 | 7     | 78            |
| 4:30 PM                         | 0                       | 0    | 0     | 0 | 0                       | 0    | 0     | 0 | 0                         | 2    | 0     | 0 | 0                         | 4    | 0     | 0 | 6     | 81            |

**Attachment B**

| 5-Min Count Period Beginning At | Antigua St (Northbound) |      |       |   | Antigua St (Southbound) |      |       |   | Bienville Ave (Eastbound) |      |       |   | Bienville Ave (Westbound) |      |       |   | Total | Hourly Totals |
|---------------------------------|-------------------------|------|-------|---|-------------------------|------|-------|---|---------------------------|------|-------|---|---------------------------|------|-------|---|-------|---------------|
|                                 | Left                    | Thru | Right | U | Left                    | Thru | Right | U | Left                      | Thru | Right | U | Left                      | Thru | Right | U |       |               |
| 4:35 PM                         | 1                       | 0    | 0     | 0 | 0                       | 0    | 1     | 0 | 1                         | 3    | 1     | 0 | 0                         | 1    | 0     | 0 | 8     | 86            |
| 4:40 PM                         | 0                       | 0    | 2     | 0 | 0                       | 0    | 0     | 0 | 0                         | 3    | 2     | 0 | 0                         | 0    | 0     | 0 | 7     | 84            |
| 4:45 PM                         | 1                       | 0    | 0     | 0 | 0                       | 0    | 0     | 0 | 1                         | 3    | 1     | 0 | 0                         | 2    | 0     | 0 | 8     | 86            |
| 4:50 PM                         | 1                       | 1    | 0     | 0 | 0                       | 1    | 0     | 0 | 0                         | 4    | 2     | 0 | 0                         | 2    | 0     | 0 | 11    | 91            |
| 4:55 PM                         | 1                       | 0    | 1     | 0 | 0                       | 0    | 0     | 0 | 0                         | 0    | 0     | 0 | 0                         | 2    | 0     | 0 | 4     | 86            |
| 5:00 PM                         | 0                       | 0    | 0     | 0 | 0                       | 0    | 0     | 0 | 0                         | 2    | 0     | 0 | 0                         | 3    | 0     | 0 | 5     | 85            |
| 5:05 PM                         | 1                       | 0    | 2     | 0 | 0                       | 0    | 0     | 0 | 0                         | 3    | 0     | 0 | 0                         | 4    | 0     | 0 | 10    | 87            |
| 5:10 PM                         | 1                       | 0    | 0     | 0 | 0                       | 0    | 0     | 0 | 0                         | 1    | 0     | 0 | 0                         | 1    | 1     | 0 | 4     | 81            |
| 5:15 PM                         | 1                       | 1    | 0     | 0 | 0                       | 0    | 0     | 0 | 0                         | 2    | 1     | 0 | 0                         | 1    | 0     | 0 | 6     | 82            |
| 5:20 PM                         | 1                       | 1    | 1     | 0 | 0                       | 0    | 1     | 0 | 0                         | 4    | 1     | 0 | 0                         | 0    | 0     | 0 | 9     | 85            |
| 5:25 PM                         | 0                       | 0    | 0     | 0 | 0                       | 1    | 0     | 0 | 2                         | 0    | 0     | 0 | 0                         | 3    | 0     | 0 | 6     | 84            |
| 5:30 PM                         | 0                       | 0    | 0     | 0 | 0                       | 0    | 1     | 0 | 0                         | 1    | 0     | 0 | 1                         | 4    | 0     | 0 | 7     | 85            |
| 5:35 PM                         | 1                       | 0    | 1     | 0 | 0                       | 0    | 0     | 0 | 2                         | 3    | 1     | 0 | 0                         | 1    | 0     | 0 | 9     | 86            |
| 5:40 PM                         | 1                       | 1    | 0     | 0 | 0                       | 0    | 0     | 0 | 0                         | 2    | 0     | 0 | 0                         | 2    | 0     | 0 | 6     | 85            |
| 5:45 PM                         | 1                       | 0    | 0     | 0 | 0                       | 1    | 0     | 0 | 0                         | 1    | 0     | 0 | 1                         | 1    | 0     | 0 | 5     | 82            |
| 5:50 PM                         | 0                       | 0    | 0     | 0 | 0                       | 0    | 0     | 0 | 0                         | 0    | 2     | 0 | 0                         | 3    | 0     | 0 | 5     | 76            |
| 5:55 PM                         | 0                       | 0    | 0     | 0 | 0                       | 0    | 0     | 0 | 2                         | 6    | 0     | 0 | 0                         | 1    | 0     | 0 | 9     | 81            |
| 6:00 PM                         | 0                       | 0    | 0     | 0 | 0                       | 0    | 1     | 0 | 1                         | 0    | 0     | 0 | 0                         | 2    | 0     | 0 | 4     | 80            |
| 6:05 PM                         | 1                       | 1    | 0     | 0 | 0                       | 1    | 0     | 0 | 1                         | 4    | 0     | 0 | 0                         | 1    | 0     | 0 | 9     | 79            |
| 6:10 PM                         | 0                       | 0    | 0     | 0 | 0                       | 0    | 0     | 0 | 0                         | 2    | 2     | 0 | 0                         | 2    | 0     | 0 | 6     | 81            |
| 6:15 PM                         | 1                       | 0    | 0     | 0 | 0                       | 0    | 0     | 0 | 0                         | 1    | 0     | 0 | 0                         | 2    | 0     | 0 | 4     | 79            |
| 6:20 PM                         | 0                       | 0    | 0     | 0 | 0                       | 0    | 0     | 0 | 1                         | 5    | 1     | 0 | 0                         | 2    | 0     | 0 | 9     | 79            |
| 6:25 PM                         | 0                       | 0    | 0     | 0 | 0                       | 0    | 0     | 0 | 0                         | 3    | 1     | 0 | 1                         | 1    | 0     | 0 | 6     | 79            |
| 6:30 PM                         | 2                       | 0    | 0     | 0 | 0                       | 0    | 0     | 0 | 0                         | 0    | 1     | 0 | 0                         | 3    | 0     | 0 | 6     | 78            |
| 6:35 PM                         | 0                       | 1    | 0     | 0 | 0                       | 0    | 0     | 0 | 0                         | 4    | 0     | 0 | 0                         | 2    | 0     | 0 | 7     | 76            |
| 6:40 PM                         | 0                       | 1    | 0     | 0 | 0                       | 0    | 0     | 0 | 1                         | 3    | 1     | 0 | 0                         | 3    | 0     | 0 | 9     | 79            |
| 6:45 PM                         | 0                       | 0    | 0     | 0 | 0                       | 0    | 1     | 0 | 0                         | 1    | 0     | 0 | 0                         | 3    | 0     | 0 | 5     | 79            |
| 6:50 PM                         | 1                       | 0    | 0     | 0 | 0                       | 0    | 0     | 0 | 0                         | 2    | 1     | 0 | 0                         | 1    | 0     | 0 | 5     | 79            |
| 6:55 PM                         | 0                       | 0    | 0     | 0 | 0                       | 0    | 0     | 0 | 0                         | 5    | 0     | 0 | 0                         | 2    | 0     | 0 | 7     | 77            |
| 7:00 PM                         | 0                       | 1    | 0     | 0 | 0                       | 0    | 1     | 0 | 0                         | 3    | 0     | 0 | 0                         | 1    | 0     | 0 | 6     | 79            |
| 7:05 PM                         | 1                       | 0    | 1     | 0 | 0                       | 2    | 0     | 0 | 1                         | 2    | 0     | 0 | 1                         | 4    | 0     | 0 | 12    | 82            |
| 7:10 PM                         | 0                       | 0    | 0     | 0 | 0                       | 0    | 0     | 0 | 0                         | 2    | 0     | 0 | 0                         | 3    | 0     | 0 | 5     | 81            |
| 7:15 PM                         | 0                       | 0    | 0     | 0 | 0                       | 0    | 0     | 0 | 0                         | 3    | 2     | 0 | 1                         | 2    | 0     | 0 | 8     | 85            |
| 7:20 PM                         | 0                       | 0    | 0     | 0 | 0                       | 0    | 0     | 0 | 0                         | 0    | 0     | 0 | 0                         | 0    | 0     | 0 | 0     | 76            |
| 7:25 PM                         | 0                       | 0    | 0     | 0 | 0                       | 0    | 0     | 0 | 1                         | 1    | 0     | 0 | 0                         | 2    | 0     | 0 | 4     | 74            |
| 7:30 PM                         | 0                       | 0    | 0     | 0 | 0                       | 0    | 0     | 0 | 1                         | 3    | 2     | 0 | 0                         | 3    | 0     | 0 | 9     | 77            |
| 7:35 PM                         | 1                       | 1    | 0     | 0 | 0                       | 0    | 0     | 0 | 0                         | 0    | 1     | 0 | 0                         | 1    | 0     | 0 | 4     | 74            |
| 7:40 PM                         | 0                       | 2    | 0     | 0 | 0                       | 2    | 1     | 0 | 0                         | 0    | 0     | 0 | 0                         | 1    | 0     | 0 | 6     | 71            |
| 7:45 PM                         | 1                       | 0    | 1     | 0 | 0                       | 0    | 0     | 0 | 0                         | 2    | 0     | 0 | 0                         | 1    | 0     | 0 | 5     | 71            |
| 7:50 PM                         | 1                       | 0    | 0     | 0 | 0                       | 0    | 0     | 0 | 0                         | 2    | 1     | 0 | 0                         | 1    | 0     | 0 | 5     | 71            |
| 7:55 PM                         | 2                       | 1    | 0     | 0 | 0                       | 0    | 0     | 0 | 1                         | 2    | 2     | 0 | 0                         | 1    | 0     | 0 | 9     | 73            |
| 8:00 PM                         | 0                       | 0    | 0     | 0 | 0                       | 1    | 0     | 0 | 1                         | 4    | 0     | 0 | 0                         | 3    | 0     | 0 | 9     | 76            |
| 8:05 PM                         | 0                       | 0    | 2     | 0 | 0                       | 0    | 1     | 0 | 0                         | 4    | 2     | 0 | 0                         | 1    | 0     | 0 | 10    | 74            |
| 8:10 PM                         | 2                       | 0    | 0     | 0 | 0                       | 0    | 0     | 0 | 0                         | 6    | 1     | 0 | 0                         | 1    | 0     | 0 | 10    | 79            |
| 8:15 PM                         | 0                       | 0    | 0     | 0 | 0                       | 0    | 0     | 0 | 1                         | 1    | 1     | 0 | 0                         | 1    | 0     | 0 | 4     | 75            |
| 8:20 PM                         | 0                       | 0    | 0     | 0 | 0                       | 0    | 0     | 0 | 0                         | 0    | 0     | 0 | 0                         | 0    | 0     | 0 | 0     | 75            |
| 8:25 PM                         | 0                       | 0    | 0     | 0 | 0                       | 0    | 0     | 0 | 0                         | 0    | 0     | 0 | 0                         | 1    | 0     | 0 | 1     | 72            |
| 8:30 PM                         | 1                       | 0    | 0     | 0 | 0                       | 0    | 0     | 0 | 0                         | 2    | 1     | 0 | 0                         | 0    | 0     | 0 | 4     | 67            |
| 8:35 PM                         | 1                       | 0    | 0     | 0 | 0                       | 0    | 0     | 0 | 0                         | 2    | 1     | 0 | 0                         | 2    | 0     | 0 | 6     | 69            |
| 8:40 PM                         | 1                       | 0    | 0     | 0 | 0                       | 0    | 0     | 0 | 0                         | 3    | 0     | 0 | 0                         | 1    | 0     | 0 | 5     | 68            |
| 8:45 PM                         | 0                       | 0    | 0     | 0 | 0                       | 0    | 0     | 0 | 0                         | 1    | 0     | 0 | 1                         | 3    | 0     | 0 | 5     | 68            |
| 8:50 PM                         | 0                       | 0    | 0     | 0 | 0                       | 0    | 0     | 0 | 0                         | 1    | 0     | 0 | 0                         | 1    | 0     | 0 | 2     | 65            |
| 8:55 PM                         | 0                       | 0    | 1     | 0 | 0                       | 0    | 0     | 0 | 0                         | 2    | 1     | 0 | 0                         | 0    | 0     | 0 | 4     | 60            |
| 9:00 PM                         | 2                       | 0    | 0     | 0 | 0                       | 0    | 0     | 0 | 0                         | 2    | 0     | 0 | 0                         | 2    | 0     | 0 | 6     | 57            |
| 9:05 PM                         | 0                       | 0    | 0     | 0 | 0                       | 0    | 0     | 0 | 0                         | 0    | 2     | 0 | 0                         | 3    | 0     | 0 | 5     | 52            |
| 9:10 PM                         | 0                       | 0    | 0     | 0 | 0                       | 0    | 0     | 0 | 0                         | 0    | 1     | 0 | 0                         | 0    | 0     | 0 | 1     | 43            |
| 9:15 PM                         | 1                       | 0    | 0     | 0 | 0                       | 0    | 0     | 0 | 0                         | 0    | 0     | 0 | 0                         | 0    | 0     | 0 | 1     | 40            |
| 9:20 PM                         | 0                       | 0    | 0     | 0 | 0                       | 0    | 0     | 0 | 0                         | 0    | 2     | 0 | 0                         | 1    | 0     | 0 | 3     | 43            |
| 9:25 PM                         | 0                       | 0    | 0     | 0 | 0                       | 0    | 0     | 0 | 0                         | 0    | 1     | 0 | 0                         | 0    | 0     | 0 | 1     | 43            |
| 9:30 PM                         | 0                       | 0    | 0     | 0 | 0                       | 0    | 0     | 0 | 1                         | 3    | 0     | 0 | 0                         | 0    | 0     | 0 | 4     | 43            |
| 9:35 PM                         | 0                       | 0    | 0     | 0 | 0                       | 0    | 0     | 0 | 0                         | 2    | 0     | 0 | 0                         | 5    | 0     | 0 | 7     | 44            |
| 9:40 PM                         | 0                       | 0    | 0     | 0 | 0                       | 0    | 0     | 0 | 0                         | 0    | 1     | 0 | 0                         | 1    | 0     | 0 | 2     | 41            |
| 9:45 PM                         | 2                       | 0    | 0     | 0 | 0                       | 0    | 0     | 0 | 0                         | 0    | 1     | 0 | 0                         | 1    | 0     | 0 | 4     | 40            |
| 9:50 PM                         | 0                       | 0    | 0     | 0 | 0                       | 0    | 0     | 0 | 0                         | 0    | 1     | 0 | 0                         | 1    | 0     | 0 | 2     | 40            |
| 9:55 PM                         | 1                       | 0    | 0     | 0 | 0                       | 0    | 0     | 0 | 1                         | 2    | 0     | 0 | 0                         | 1    | 0     | 0 | 5     | 41            |
| Peak 15-Min Flowrates           | Northbound              |      |       |   | Southbound              |      |       |   | Eastbound                 |      |       |   | Westbound                 |      |       |   | Total |               |
|                                 | Left                    | Thru | Right | U | Left                    | Thru | Right | U | Left                      | Thru | Right | U | Left                      | Thru | Right | U |       |               |
| All Vehicles                    | 20                      | 4    | 4     | 0 | 0                       | 12   | 12    | 0 | 8                         | 20   | 8     | 0 | 4                         | 60   | 0     | 0 | 152   |               |
| Heavy Trucks                    | 0                       | 0    | 0     | 0 | 0                       | 0    | 4     | 0 | 4                         | 0    | 0     | 0 | 0                         | 0    | 0     | 0 | 8     |               |
| Buses                           |                         | 4    |       |   |                         | 0    |       |   |                           | 0    |       |   |                           | 0    |       |   | 4     |               |
| Pedestrians                     | 0                       | 0    | 0     | 0 | 0                       | 0    | 0     | 0 | 0                         | 0    | 0     | 0 | 0                         | 0    | 0     | 0 | 0     |               |
| Bicycles                        |                         |      |       |   |                         |      |       |   |                           |      |       |   |                           |      |       |   |       |               |
| Scoters                         |                         |      |       |   |                         |      |       |   |                           |      |       |   |                           |      |       |   |       |               |

Comments:

LOCATION: Endry St -- Banta Ave  
 CITY/STATE: Orange, CA

QC JOB #: 16966404  
 DATE: Wed, Apr 9 2025

Peak-Hour: 7:25 AM -- 8:25 AM  
 Peak 15-Min: 7:45 AM -- 8:00 AM

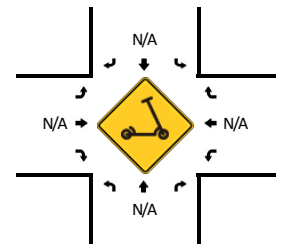
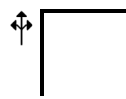
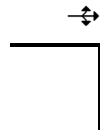
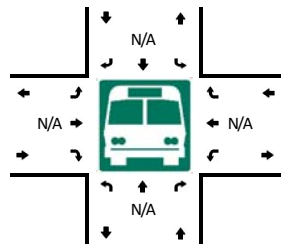
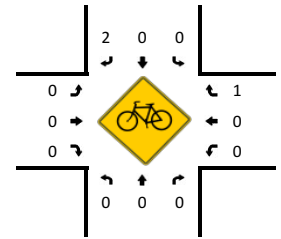
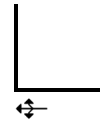
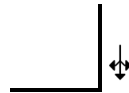
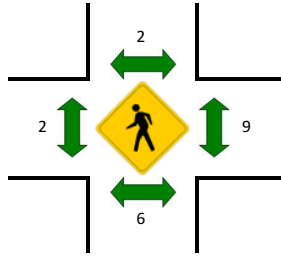
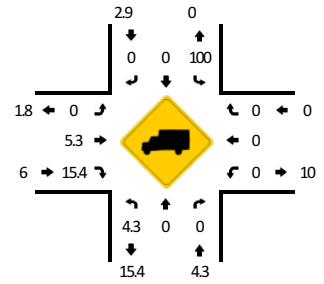
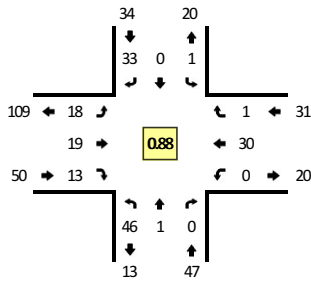

| 5-Min Count Period Beginning At | Endry St (Northbound) |      |       |   | Endry St (Southbound) |      |       |   | Banta Ave (Eastbound) |      |       |   | Banta Ave (Westbound) |      |       |   | Total | Hourly Totals |     |
|---------------------------------|-----------------------|------|-------|---|-----------------------|------|-------|---|-----------------------|------|-------|---|-----------------------|------|-------|---|-------|---------------|-----|
|                                 | Left                  | Thru | Right | U | Left                  | Thru | Right | U | Left                  | Thru | Right | U | Left                  | Thru | Right | U |       |               |     |
| 6:00 AM                         | 3                     | 0    | 0     | 0 | 0                     | 0    | 6     | 0 | 0                     | 0    | 0     | 0 | 0                     | 1    | 0     | 0 | 0     | 10            |     |
| 6:05 AM                         | 3                     | 0    | 1     | 0 | 0                     | 0    | 1     | 0 | 1                     | 0    | 0     | 0 | 0                     | 1    | 0     | 0 | 0     | 7             |     |
| 6:10 AM                         | 2                     | 0    | 0     | 0 | 0                     | 0    | 2     | 0 | 0                     | 0    | 0     | 0 | 0                     | 0    | 0     | 0 | 0     | 4             |     |
| 6:15 AM                         | 0                     | 0    | 0     | 0 | 0                     | 0    | 0     | 0 | 0                     | 0    | 1     | 0 | 0                     | 0    | 0     | 0 | 0     | 1             |     |
| 6:20 AM                         | 1                     | 0    | 0     | 0 | 0                     | 0    | 0     | 0 | 0                     | 0    | 0     | 0 | 0                     | 1    | 0     | 0 | 0     | 2             |     |
| 6:25 AM                         | 6                     | 0    | 0     | 0 | 0                     | 0    | 1     | 0 | 0                     | 0    | 0     | 0 | 0                     | 1    | 0     | 0 | 0     | 8             |     |
| 6:30 AM                         | 1                     | 0    | 0     | 0 | 0                     | 0    | 0     | 0 | 0                     | 1    | 0     | 0 | 0                     | 0    | 0     | 0 | 0     | 2             |     |
| 6:35 AM                         | 2                     | 0    | 0     | 0 | 0                     | 0    | 0     | 0 | 0                     | 1    | 0     | 0 | 0                     | 0    | 0     | 0 | 0     | 3             |     |
| 6:40 AM                         | 1                     | 0    | 0     | 0 | 0                     | 0    | 1     | 0 | 1                     | 2    | 0     | 0 | 0                     | 2    | 0     | 0 | 0     | 7             |     |
| 6:45 AM                         | 1                     | 0    | 0     | 0 | 0                     | 0    | 3     | 0 | 0                     | 2    | 0     | 0 | 0                     | 2    | 0     | 0 | 0     | 8             |     |
| 6:50 AM                         | 0                     | 0    | 0     | 0 | 0                     | 0    | 2     | 0 | 0                     | 0    | 1     | 0 | 0                     | 5    | 0     | 0 | 0     | 8             |     |
| 6:55 AM                         | 0                     | 0    | 0     | 0 | 0                     | 0    | 3     | 0 | 0                     | 0    | 0     | 0 | 0                     | 0    | 0     | 0 | 0     | 3             | 63  |
| 7:00 AM                         | 4                     | 0    | 0     | 0 | 0                     | 0    | 4     | 0 | 1                     | 0    | 0     | 0 | 0                     | 2    | 0     | 0 | 0     | 11            | 64  |
| 7:05 AM                         | 2                     | 0    | 0     | 0 | 0                     | 0    | 1     | 0 | 1                     | 0    | 0     | 0 | 0                     | 1    | 0     | 0 | 0     | 5             | 62  |
| 7:10 AM                         | 1                     | 0    | 0     | 0 | 0                     | 0    | 3     | 0 | 2                     | 1    | 0     | 0 | 0                     | 2    | 0     | 0 | 0     | 9             | 67  |
| 7:15 AM                         | 2                     | 0    | 0     | 0 | 0                     | 0    | 2     | 0 | 1                     | 0    | 1     | 0 | 0                     | 3    | 0     | 0 | 0     | 9             | 75  |
| 7:20 AM                         | 5                     | 0    | 0     | 0 | 1                     | 0    | 2     | 0 | 1                     | 1    | 0     | 0 | 0                     | 1    | 0     | 0 | 0     | 11            | 84  |
| 7:25 AM                         | 1                     | 0    | 0     | 0 | 0                     | 0    | 2     | 0 | 1                     | 0    | 1     | 0 | 0                     | 3    | 0     | 0 | 0     | 8             | 84  |
| 7:30 AM                         | 4                     | 0    | 0     | 0 | 0                     | 0    | 5     | 0 | 2                     | 1    | 0     | 0 | 0                     | 0    | 0     | 0 | 0     | 12            | 94  |
| 7:35 AM                         | 5                     | 0    | 0     | 0 | 0                     | 0    | 3     | 0 | 1                     | 1    | 0     | 0 | 0                     | 5    | 0     | 0 | 0     | 15            | 106 |
| 7:40 AM                         | 5                     | 0    | 0     | 0 | 0                     | 0    | 2     | 0 | 0                     | 0    | 2     | 0 | 0                     | 2    | 0     | 0 | 0     | 11            | 110 |
| 7:45 AM                         | 4                     | 0    | 0     | 0 | 0                     | 0    | 4     | 0 | 2                     | 4    | 0     | 0 | 0                     | 5    | 0     | 0 | 0     | 19            | 121 |
| 7:50 AM                         | 4                     | 1    | 0     | 0 | 0                     | 0    | 2     | 0 | 1                     | 3    | 1     | 0 | 0                     | 1    | 1     | 0 | 0     | 14            | 127 |
| 7:55 AM                         | 3                     | 0    | 0     | 0 | 1                     | 0    | 2     | 0 | 1                     | 2    | 1     | 0 | 0                     | 3    | 0     | 0 | 0     | 13            | 137 |
| 8:00 AM                         | 5                     | 0    | 0     | 0 | 0                     | 0    | 0     | 0 | 3                     | 2    | 3     | 0 | 0                     | 4    | 0     | 0 | 0     | 17            | 143 |
| 8:05 AM                         | 3                     | 0    | 0     | 0 | 0                     | 0    | 1     | 0 | 3                     | 2    | 2     | 0 | 0                     | 2    | 0     | 0 | 0     | 13            | 151 |
| 8:10 AM                         | 1                     | 0    | 0     | 0 | 0                     | 0    | 4     | 0 | 2                     | 2    | 2     | 0 | 0                     | 3    | 0     | 0 | 0     | 14            | 156 |
| 8:15 AM                         | 2                     | 0    | 0     | 0 | 0                     | 0    | 5     | 0 | 0                     | 1    | 1     | 0 | 0                     | 0    | 0     | 0 | 0     | 9             | 156 |
| 8:20 AM                         | 9                     | 0    | 0     | 0 | 0                     | 0    | 3     | 0 | 2                     | 1    | 0     | 0 | 0                     | 2    | 0     | 0 | 0     | 17            | 162 |
| 8:25 AM                         | 0                     | 0    | 0     | 0 | 0                     | 0    | 1     | 0 | 1                     | 0    | 0     | 0 | 0                     | 0    | 0     | 0 | 0     | 2             | 156 |
| 8:30 AM                         | 1                     | 0    | 0     | 0 | 0                     | 0    | 1     | 0 | 0                     | 3    | 0     | 0 | 0                     | 0    | 0     | 0 | 0     | 5             | 149 |
| 8:35 AM                         | 2                     | 0    | 0     | 0 | 0                     | 0    | 4     | 0 | 2                     | 2    | 1     | 0 | 0                     | 1    | 0     | 0 | 0     | 12            | 146 |
| 8:40 AM                         | 3                     | 0    | 0     | 0 | 0                     | 0    | 2     | 0 | 0                     | 1    | 0     | 0 | 0                     | 0    | 0     | 0 | 0     | 6             | 141 |
| 8:45 AM                         | 3                     | 0    | 0     | 0 | 0                     | 0    | 1     | 0 | 3                     | 0    | 1     | 0 | 0                     | 1    | 0     | 0 | 0     | 9             | 131 |
| 8:50 AM                         | 2                     | 0    | 0     | 0 | 0                     | 0    | 1     | 0 | 0                     | 1    | 0     | 0 | 0                     | 1    | 0     | 0 | 0     | 5             | 122 |
| 8:55 AM                         | 0                     | 0    | 0     | 0 | 0                     | 1    | 1     | 0 | 1                     | 0    | 0     | 0 | 0                     | 2    | 0     | 0 | 0     | 5             | 114 |
| 9:00 AM                         | 0                     | 0    | 0     | 0 | 0                     | 0    | 2     | 0 | 0                     | 0    | 2     | 0 | 0                     | 1    | 0     | 0 | 0     | 5             | 102 |
| 9:05 AM                         | 1                     | 0    | 0     | 0 | 0                     | 0    | 0     | 0 | 1                     | 3    | 0     | 0 | 0                     | 0    | 0     | 0 | 0     | 5             | 94  |

Attachment B

| 5-Min Count Period Beginning At | Endry St (Northbound) |      |       |   | Endry St (Southbound) |      |       |   | Banta Ave (Eastbound) |      |       |   | Banta Ave (Westbound) |      |       |   | Total | Hourly Totals |
|---------------------------------|-----------------------|------|-------|---|-----------------------|------|-------|---|-----------------------|------|-------|---|-----------------------|------|-------|---|-------|---------------|
|                                 | Left                  | Thru | Right | U | Left                  | Thru | Right | U | Left                  | Thru | Right | U | Left                  | Thru | Right | U |       |               |
| 9:10 AM                         | 2                     | 0    | 0     | 0 | 0                     | 0    | 1     | 0 | 1                     | 1    | 0     | 0 | 0                     | 0    | 0     | 0 | 5     | 85            |
| 9:15 AM                         | 0                     | 0    | 0     | 0 | 0                     | 0    | 1     | 0 | 0                     | 1    | 1     | 0 | 0                     | 0    | 1     | 0 | 4     | 80            |
| 9:20 AM                         | 2                     | 0    | 0     | 0 | 0                     | 0    | 0     | 0 | 1                     | 0    | 0     | 0 | 0                     | 0    | 0     | 0 | 3     | 66            |
| 9:25 AM                         | 2                     | 0    | 0     | 0 | 0                     | 0    | 0     | 0 | 1                     | 0    | 1     | 0 | 0                     | 1    | 0     | 0 | 5     | 69            |
| 9:30 AM                         | 1                     | 0    | 0     | 0 | 0                     | 0    | 1     | 0 | 2                     | 0    | 1     | 0 | 0                     | 3    | 0     | 0 | 8     | 72            |
| 9:35 AM                         | 1                     | 0    | 0     | 0 | 0                     | 0    | 0     | 0 | 0                     | 0    | 0     | 0 | 0                     | 1    | 0     | 0 | 2     | 62            |
| 9:40 AM                         | 4                     | 0    | 0     | 0 | 0                     | 0    | 0     | 0 | 2                     | 0    | 1     | 0 | 0                     | 0    | 0     | 0 | 7     | 63            |
| 9:45 AM                         | 4                     | 0    | 0     | 0 | 0                     | 0    | 1     | 0 | 0                     | 0    | 1     | 0 | 1                     | 3    | 0     | 0 | 10    | 64            |
| 9:50 AM                         | 3                     | 0    | 0     | 0 | 0                     | 0    | 0     | 0 | 1                     | 0    | 5     | 0 | 0                     | 2    | 0     | 0 | 11    | 70            |
| 9:55 AM                         | 0                     | 0    | 0     | 0 | 0                     | 0    | 3     | 0 | 0                     | 0    | 0     | 0 | 0                     | 2    | 0     | 0 | 5     | 70            |
| 10:00 AM                        | 2                     | 0    | 0     | 0 | 0                     | 0    | 1     | 0 | 0                     | 1    | 0     | 0 | 0                     | 0    | 0     | 0 | 4     | 69            |
| 10:05 AM                        | 2                     | 0    | 0     | 0 | 0                     | 0    | 0     | 0 | 1                     | 2    | 2     | 0 | 0                     | 0    | 0     | 0 | 7     | 71            |
| 10:10 AM                        | 2                     | 0    | 0     | 0 | 0                     | 0    | 0     | 0 | 0                     | 2    | 2     | 0 | 0                     | 1    | 0     | 0 | 7     | 73            |
| 10:15 AM                        | 1                     | 0    | 0     | 0 | 0                     | 0    | 2     | 0 | 3                     | 1    | 0     | 0 | 0                     | 0    | 0     | 0 | 7     | 76            |
| 10:20 AM                        | 3                     | 0    | 0     | 0 | 0                     | 0    | 1     | 0 | 2                     | 0    | 0     | 0 | 0                     | 1    | 0     | 0 | 7     | 80            |
| 10:25 AM                        | 2                     | 0    | 0     | 0 | 1                     | 0    | 1     | 0 | 1                     | 1    | 0     | 0 | 0                     | 1    | 0     | 0 | 7     | 82            |
| 10:30 AM                        | 2                     | 0    | 0     | 0 | 0                     | 0    | 5     | 0 | 1                     | 0    | 3     | 0 | 0                     | 4    | 0     | 0 | 15    | 89            |
| 10:35 AM                        | 1                     | 0    | 0     | 0 | 0                     | 1    | 0     | 0 | 0                     | 1    | 2     | 0 | 0                     | 2    | 0     | 0 | 7     | 94            |
| 10:40 AM                        | 0                     | 0    | 0     | 0 | 0                     | 1    | 2     | 0 | 1                     | 1    | 2     | 0 | 0                     | 2    | 0     | 0 | 9     | 96            |
| 10:45 AM                        | 3                     | 0    | 0     | 0 | 0                     | 0    | 0     | 0 | 0                     | 1    | 1     | 0 | 0                     | 1    | 0     | 0 | 6     | 92            |
| 10:50 AM                        | 1                     | 0    | 0     | 0 | 0                     | 0    | 0     | 0 | 0                     | 1    | 1     | 0 | 0                     | 2    | 0     | 0 | 5     | 86            |
| 10:55 AM                        | 1                     | 0    | 0     | 0 | 0                     | 1    | 0     | 0 | 0                     | 0    | 0     | 0 | 0                     | 1    | 0     | 0 | 3     | 84            |
| 11:00 AM                        | 1                     | 0    | 0     | 0 | 0                     | 0    | 2     | 0 | 1                     | 0    | 1     | 0 | 0                     | 2    | 0     | 0 | 7     | 87            |
| 11:05 AM                        | 0                     | 0    | 0     | 0 | 0                     | 0    | 1     | 0 | 3                     | 0    | 1     | 0 | 0                     | 2    | 0     | 0 | 7     | 87            |
| 11:10 AM                        | 0                     | 0    | 0     | 0 | 0                     | 1    | 2     | 0 | 0                     | 0    | 0     | 0 | 0                     | 0    | 0     | 0 | 3     | 83            |
| 11:15 AM                        | 2                     | 0    | 0     | 0 | 0                     | 0    | 1     | 0 | 1                     | 1    | 0     | 0 | 0                     | 0    | 0     | 0 | 5     | 81            |
| 11:20 AM                        | 1                     | 0    | 1     | 0 | 0                     | 0    | 0     | 0 | 1                     | 2    | 1     | 0 | 0                     | 1    | 0     | 0 | 7     | 81            |
| 11:25 AM                        | 0                     | 0    | 0     | 0 | 0                     | 0    | 0     | 0 | 0                     | 0    | 3     | 0 | 1                     | 1    | 0     | 0 | 5     | 79            |
| 11:30 AM                        | 1                     | 0    | 1     | 0 | 0                     | 1    | 0     | 0 | 1                     | 0    | 0     | 0 | 0                     | 2    | 0     | 0 | 6     | 70            |
| 11:35 AM                        | 1                     | 0    | 0     | 0 | 0                     | 0    | 1     | 0 | 0                     | 0    | 2     | 0 | 0                     | 0    | 0     | 0 | 4     | 67            |
| 11:40 AM                        | 2                     | 0    | 0     | 0 | 0                     | 0    | 2     | 0 | 2                     | 0    | 0     | 0 | 0                     | 2    | 0     | 0 | 8     | 66            |
| 11:45 AM                        | 4                     | 0    | 0     | 0 | 0                     | 0    | 1     | 0 | 3                     | 1    | 0     | 0 | 0                     | 0    | 0     | 0 | 9     | 69            |
| 11:50 AM                        | 0                     | 0    | 0     | 0 | 0                     | 0    | 2     | 0 | 1                     | 1    | 0     | 0 | 0                     | 4    | 0     | 0 | 8     | 72            |
| 11:55 AM                        | 1                     | 0    | 0     | 0 | 0                     | 0    | 3     | 0 | 0                     | 1    | 0     | 0 | 0                     | 1    | 0     | 0 | 6     | 75            |
| 12:00 PM                        | 2                     | 0    | 0     | 0 | 0                     | 0    | 0     | 0 | 0                     | 0    | 0     | 0 | 0                     | 1    | 1     | 0 | 4     | 72            |
| 12:05 PM                        | 0                     | 0    | 0     | 0 | 0                     | 0    | 2     | 0 | 0                     | 2    | 1     | 0 | 0                     | 0    | 0     | 0 | 5     | 70            |
| 12:10 PM                        | 1                     | 0    | 0     | 0 | 0                     | 0    | 1     | 0 | 1                     | 0    | 1     | 0 | 0                     | 1    | 0     | 0 | 5     | 72            |
| 12:15 PM                        | 1                     | 0    | 0     | 0 | 0                     | 0    | 3     | 0 | 2                     | 0    | 0     | 0 | 0                     | 1    | 0     | 0 | 7     | 74            |
| 12:20 PM                        | 1                     | 0    | 0     | 0 | 0                     | 0    | 5     | 0 | 1                     | 0    | 0     | 0 | 0                     | 2    | 0     | 0 | 9     | 76            |
| 12:25 PM                        | 0                     | 1    | 0     | 0 | 0                     | 2    | 2     | 0 | 2                     | 0    | 0     | 0 | 0                     | 0    | 0     | 0 | 7     | 78            |
| 12:30 PM                        | 1                     | 0    | 0     | 0 | 0                     | 0    | 0     | 0 | 1                     | 2    | 1     | 0 | 0                     | 0    | 0     | 0 | 5     | 77            |
| 12:35 PM                        | 1                     | 0    | 0     | 0 | 0                     | 0    | 4     | 0 | 0                     | 2    | 0     | 0 | 0                     | 2    | 1     | 0 | 10    | 83            |
| 12:40 PM                        | 1                     | 0    | 0     | 0 | 0                     | 0    | 1     | 0 | 1                     | 3    | 0     | 0 | 0                     | 4    | 0     | 0 | 10    | 85            |
| 12:45 PM                        | 2                     | 0    | 0     | 0 | 0                     | 0    | 1     | 0 | 2                     | 1    | 1     | 0 | 0                     | 0    | 0     | 0 | 7     | 83            |
| 12:50 PM                        | 4                     | 0    | 0     | 0 | 0                     | 0    | 1     | 0 | 1                     | 1    | 1     | 0 | 0                     | 1    | 0     | 0 | 9     | 84            |
| 12:55 PM                        | 1                     | 0    | 0     | 0 | 0                     | 0    | 2     | 0 | 0                     | 1    | 1     | 0 | 0                     | 1    | 0     | 0 | 6     | 84            |
| 1:00 PM                         | 0                     | 0    | 0     | 0 | 0                     | 0    | 2     | 0 | 1                     | 1    | 2     | 0 | 0                     | 1    | 0     | 0 | 7     | 87            |
| 1:05 PM                         | 2                     | 0    | 0     | 0 | 0                     | 0    | 0     | 0 | 2                     | 2    | 2     | 0 | 0                     | 0    | 0     | 0 | 8     | 90            |
| 1:10 PM                         | 0                     | 0    | 0     | 0 | 0                     | 0    | 3     | 0 | 1                     | 1    | 2     | 0 | 0                     | 1    | 0     | 0 | 8     | 93            |
| 1:15 PM                         | 1                     | 0    | 0     | 0 | 0                     | 0    | 1     | 0 | 2                     | 2    | 1     | 0 | 0                     | 0    | 0     | 0 | 7     | 93            |
| 1:20 PM                         | 2                     | 0    | 0     | 0 | 0                     | 0    | 0     | 0 | 0                     | 1    | 2     | 0 | 0                     | 1    | 1     | 0 | 7     | 91            |
| 1:25 PM                         | 1                     | 1    | 0     | 0 | 1                     | 0    | 1     | 0 | 1                     | 1    | 0     | 0 | 2                     | 0    | 0     | 0 | 8     | 92            |
| 1:30 PM                         | 1                     | 0    | 0     | 0 | 0                     | 0    | 2     | 0 | 1                     | 2    | 1     | 0 | 0                     | 2    | 0     | 0 | 9     | 96            |
| 1:35 PM                         | 0                     | 0    | 0     | 0 | 1                     | 0    | 2     | 0 | 1                     | 1    | 0     | 0 | 0                     | 1    | 0     | 0 | 6     | 92            |
| 1:40 PM                         | 1                     | 0    | 0     | 0 | 0                     | 0    | 1     | 0 | 0                     | 1    | 1     | 0 | 0                     | 0    | 0     | 0 | 4     | 86            |
| 1:45 PM                         | 0                     | 0    | 0     | 0 | 0                     | 1    | 2     | 0 | 0                     | 0    | 0     | 0 | 0                     | 0    | 0     | 0 | 3     | 82            |
| 1:50 PM                         | 2                     | 0    | 0     | 0 | 0                     | 0    | 1     | 0 | 2                     | 0    | 1     | 0 | 0                     | 1    | 0     | 0 | 7     | 80            |
| 1:55 PM                         | 0                     | 0    | 0     | 0 | 0                     | 0    | 1     | 0 | 2                     | 0    | 0     | 0 | 0                     | 1    | 0     | 0 | 4     | 78            |
| 2:00 PM                         | 0                     | 0    | 0     | 0 | 0                     | 0    | 2     | 0 | 0                     | 0    | 0     | 0 | 0                     | 1    | 0     | 0 | 3     | 74            |
| 2:05 PM                         | 1                     | 0    | 0     | 0 | 0                     | 0    | 4     | 0 | 2                     | 0    | 0     | 0 | 0                     | 1    | 0     | 0 | 8     | 74            |
| 2:10 PM                         | 2                     | 0    | 0     | 0 | 0                     | 0    | 0     | 0 | 1                     | 2    | 1     | 0 | 0                     | 0    | 1     | 0 | 7     | 73            |
| 2:15 PM                         | 0                     | 0    | 0     | 0 | 0                     | 0    | 3     | 0 | 0                     | 1    | 0     | 0 | 0                     | 2    | 0     | 0 | 6     | 72            |
| 2:20 PM                         | 0                     | 0    | 0     | 0 | 0                     | 0    | 1     | 0 | 0                     | 1    | 1     | 0 | 0                     | 2    | 0     | 0 | 5     | 70            |
| 2:25 PM                         | 0                     | 0    | 0     | 0 | 1                     | 0    | 0     | 0 | 0                     | 2    | 0     | 0 | 0                     | 4    | 0     | 0 | 7     | 69            |
| 2:30 PM                         | 1                     | 1    | 0     | 0 | 0                     | 0    | 3     | 0 | 0                     | 4    | 3     | 0 | 0                     | 2    | 0     | 0 | 14    | 74            |
| 2:35 PM                         | 4                     | 0    | 0     | 0 | 0                     | 0    | 0     | 0 | 0                     | 0    | 0     | 0 | 0                     | 1    | 0     | 0 | 5     | 73            |
| 2:40 PM                         | 3                     | 0    | 1     | 0 | 0                     | 0    | 1     | 0 | 2                     | 0    | 1     | 0 | 0                     | 2    | 0     | 0 | 10    | 79            |
| 2:45 PM                         | 0                     | 0    | 0     | 0 | 0                     | 0    | 2     | 0 | 2                     | 1    | 1     | 0 | 0                     | 1    | 0     | 0 | 7     | 83            |
| 2:50 PM                         | 2                     | 0    | 0     | 0 | 0                     | 0    | 1     | 0 | 3                     | 0    | 2     | 0 | 0                     | 1    | 0     | 0 | 9     | 85            |
| 2:55 PM                         | 1                     | 0    | 0     | 0 | 0                     | 0    | 1     | 0 | 1                     | 0    | 1     | 0 | 0                     | 4    | 0     | 0 | 8     | 89            |
| 3:00 PM                         | 1                     | 0    | 0     | 0 | 0                     | 0    | 2     | 0 | 0                     | 2    | 0     | 0 | 0                     | 1    | 0     | 0 | 6     | 92            |
| 3:05 PM                         | 1                     | 1    | 0     | 0 | 0                     | 0    | 2     | 0 | 2                     | 1    | 1     | 0 | 0                     | 0    | 0     | 0 | 8     | 92            |
| 3:10 PM                         | 0                     | 0    | 0     | 0 | 0                     | 0    | 5     | 0 | 0                     | 0    | 1     | 0 | 1                     | 0    | 0     | 0 | 7     | 92            |
| 3:15 PM                         | 2                     | 0    | 1     | 0 | 1                     | 0    | 3     | 0 | 2                     | 2    | 0     | 0 | 1                     | 2    | 0     | 0 | 14    | 100           |
| 3:20 PM                         | 2                     | 0    | 0     | 0 | 0                     | 1    | 3     | 0 | 3                     | 0    | 0     | 0 | 0                     | 0    | 0     | 0 | 9     | 104           |
| 3:25 PM                         | 2                     | 0    | 0     | 0 | 0                     | 1    | 4     | 0 | 4                     | 1    | 1     | 0 | 0                     | 2    | 0     | 0 | 15    | 112           |
| 3:30 PM                         | 2                     | 0    | 0     | 0 | 0                     | 0    | 3     | 0 | 0                     | 0    | 3     | 0 | 0                     | 1    | 0     | 0 | 9     | 107           |
| 3:35 PM                         | 1                     | 0    | 0     | 0 | 0                     | 0    | 2     | 0 | 1                     | 1    | 3     | 0 | 0                     | 1    | 0     | 0 | 9     | 111           |
| 3:40 PM                         | 3                     | 0    | 0     | 0 | 0                     | 0    | 1     | 0 | 2                     | 2    | 2     | 0 | 0                     | 1    | 0     | 0 | 11    | 112           |
| 3:45 PM                         | 0                     | 0    | 0     | 0 | 0                     | 0    | 1     | 0 | 0                     | 0    | 1     | 0 | 0                     | 0    | 0     | 0 | 2     | 107           |
| 3:50 PM                         | 0                     | 1    | 0     | 0 | 0                     | 1    | 4     | 0 | 0                     | 2    | 2     | 0 | 0                     | 3    | 0     | 0 | 13    | 111           |
| 3:55 PM                         | 2                     | 0    | 0     | 0 | 0                     | 0    | 0     | 0 | 3                     | 2    | 0     | 0 | 0                     | 2    | 0     | 0 | 9     | 112           |
| 4:00 PM                         | 0                     | 0    | 0     | 0 | 0                     | 0    | 1     | 0 | 0                     | 1    | 1     | 0 | 0                     | 0    | 1     | 0 | 4     | 110           |
| 4:05 PM                         | 3                     | 0    | 0     | 0 | 0                     | 0    | 2     | 0 | 2                     | 1    | 1     | 0 | 0                     | 1    | 0     | 0 | 10    | 112           |
| 4:10 PM                         | 3                     | 0    | 0     | 0 | 0                     | 0    | 5     | 0 | 2                     | 1    | 1     | 0 | 0                     | 1    | 1     | 0 | 14    | 119           |
| 4:15 PM                         | 2                     | 0    | 0     | 0 | 0                     | 0    | 0     | 0 | 0                     | 3    | 1     | 0 | 0                     | 2    | 0     | 0 | 8     | 113           |
| 4:20 PM                         | 0                     | 0    | 1     | 0 | 0                     | 0    | 6     | 0 | 1                     | 0    | 3     | 0 | 0                     | 1    | 0     | 0 | 12    | 116           |
| 4:25 PM                         | 0                     | 0    | 0     | 0 | 0                     | 0    | 2     | 0 | 0                     | 2    | 1     | 0 | 0                     | 1    | 0     | 0 | 6     | 107           |
| 4:30 PM                         | 1                     | 0    | 0     | 0 | 0                     | 0    | 4     | 0 | 0                     | 0    | 0     | 0 | 0                     | 1    | 0     | 0 | 6     | 104           |

## Attachment B

| 5-Min Count Period Beginning At | Endry St (Northbound) |      |       |   | Endry St (Southbound) |      |       |   | Banta Ave (Eastbound) |      |       |   | Banta Ave (Westbound) |      |       |   | Total | Hourly Totals |
|---------------------------------|-----------------------|------|-------|---|-----------------------|------|-------|---|-----------------------|------|-------|---|-----------------------|------|-------|---|-------|---------------|
|                                 | Left                  | Thru | Right | U | Left                  | Thru | Right | U | Left                  | Thru | Right | U | Left                  | Thru | Right | U |       |               |
| 4:35 PM                         | 1                     | 0    | 0     | 0 | 1                     | 0    | 2     | 0 | 2                     | 1    | 4     | 0 | 0                     | 1    | 0     | 0 | 12    | 107           |
| 4:40 PM                         | 0                     | 0    | 0     | 0 | 0                     | 0    | 2     | 0 | 2                     | 1    | 2     | 0 | 0                     | 1    | 1     | 0 | 9     | 105           |
| 4:45 PM                         | 0                     | 0    | 0     | 0 | 0                     | 0    | 6     | 0 | 1                     | 1    | 1     | 0 | 0                     | 0    | 0     | 0 | 9     | 112           |
| 4:50 PM                         | 2                     | 1    | 0     | 0 | 0                     | 0    | 3     | 0 | 3                     | 2    | 4     | 0 | 0                     | 1    | 0     | 0 | 16    | 115           |
| 4:55 PM                         | 0                     | 0    | 0     | 0 | 0                     | 0    | 1     | 0 | 3                     | 1    | 1     | 0 | 0                     | 3    | 0     | 0 | 9     | 115           |
| 5:00 PM                         | 2                     | 0    | 1     | 0 | 0                     | 1    | 2     | 0 | 2                     | 1    | 2     | 0 | 0                     | 0    | 0     | 0 | 11    | 122           |
| 5:05 PM                         | 0                     | 0    | 0     | 0 | 0                     | 1    | 4     | 0 | 0                     | 0    | 1     | 0 | 0                     | 0    | 0     | 0 | 6     | 118           |
| 5:10 PM                         | 2                     | 0    | 0     | 0 | 0                     | 1    | 5     | 0 | 1                     | 3    | 4     | 0 | 0                     | 3    | 0     | 0 | 19    | 123           |
| 5:15 PM                         | 2                     | 0    | 0     | 0 | 0                     | 0    | 5     | 0 | 0                     | 2    | 1     | 0 | 0                     | 1    | 0     | 0 | 11    | 126           |
| 5:20 PM                         | 0                     | 0    | 0     | 0 | 0                     | 0    | 0     | 0 | 0                     | 3    | 1     | 0 | 0                     | 1    | 0     | 0 | 5     | 119           |
| 5:25 PM                         | 1                     | 0    | 0     | 0 | 0                     | 1    | 1     | 0 | 2                     | 1    | 2     | 0 | 0                     | 1    | 0     | 0 | 9     | 122           |
| 5:30 PM                         | 1                     | 0    | 0     | 0 | 0                     | 0    | 0     | 0 | 1                     | 0    | 1     | 0 | 0                     | 0    | 0     | 0 | 3     | 119           |
| 5:35 PM                         | 0                     | 0    | 0     | 0 | 0                     | 0    | 4     | 0 | 0                     | 2    | 0     | 0 | 0                     | 1    | 0     | 0 | 7     | 114           |
| 5:40 PM                         | 2                     | 0    | 0     | 0 | 0                     | 0    | 3     | 0 | 0                     | 1    | 2     | 0 | 0                     | 0    | 0     | 0 | 8     | 113           |
| 5:45 PM                         | 2                     | 0    | 1     | 0 | 0                     | 0    | 0     | 0 | 0                     | 0    | 3     | 0 | 0                     | 2    | 0     | 0 | 8     | 112           |
| 5:50 PM                         | 3                     | 0    | 0     | 0 | 0                     | 1    | 6     | 0 | 0                     | 3    | 3     | 0 | 0                     | 2    | 0     | 0 | 18    | 114           |
| 5:55 PM                         | 3                     | 0    | 0     | 0 | 0                     | 0    | 1     | 0 | 4                     | 2    | 0     | 0 | 0                     | 3    | 0     | 0 | 13    | 118           |
| 6:00 PM                         | 1                     | 0    | 0     | 0 | 0                     | 0    | 2     | 0 | 0                     | 0    | 1     | 0 | 0                     | 0    | 0     | 0 | 4     | 111           |
| 6:05 PM                         | 2                     | 0    | 0     | 0 | 0                     | 0    | 2     | 0 | 2                     | 0    | 2     | 0 | 0                     | 0    | 0     | 0 | 8     | 113           |
| 6:10 PM                         | 1                     | 0    | 0     | 0 | 0                     | 0    | 0     | 0 | 0                     | 2    | 2     | 0 | 0                     | 1    | 0     | 0 | 6     | 100           |
| 6:15 PM                         | 2                     | 0    | 0     | 0 | 0                     | 2    | 3     | 0 | 1                     | 2    | 1     | 0 | 0                     | 1    | 0     | 0 | 12    | 101           |
| 6:20 PM                         | 4                     | 0    | 0     | 0 | 0                     | 1    | 0     | 0 | 2                     | 0    | 0     | 0 | 0                     | 3    | 0     | 0 | 10    | 106           |
| 6:25 PM                         | 4                     | 0    | 0     | 0 | 0                     | 0    | 1     | 0 | 1                     | 0    | 1     | 0 | 0                     | 0    | 0     | 0 | 7     | 104           |
| 6:30 PM                         | 2                     | 0    | 0     | 0 | 0                     | 0    | 1     | 0 | 0                     | 1    | 1     | 0 | 1                     | 0    | 0     | 0 | 6     | 107           |
| 6:35 PM                         | 2                     | 0    | 0     | 0 | 0                     | 1    | 2     | 0 | 3                     | 2    | 2     | 0 | 0                     | 1    | 0     | 0 | 13    | 113           |
| 6:40 PM                         | 2                     | 0    | 0     | 0 | 0                     | 0    | 1     | 0 | 0                     | 2    | 1     | 0 | 0                     | 0    | 0     | 0 | 6     | 111           |
| 6:45 PM                         | 2                     | 0    | 0     | 0 | 0                     | 0    | 2     | 0 | 5                     | 1    | 2     | 0 | 0                     | 0    | 0     | 0 | 12    | 115           |
| 6:50 PM                         | 3                     | 0    | 0     | 0 | 1                     | 0    | 2     | 0 | 3                     | 2    | 1     | 0 | 0                     | 2    | 0     | 0 | 14    | 111           |
| 6:55 PM                         | 1                     | 0    | 0     | 0 | 0                     | 0    | 0     | 0 | 0                     | 0    | 1     | 0 | 0                     | 0    | 0     | 0 | 2     | 100           |
| 7:00 PM                         | 1                     | 0    | 0     | 0 | 0                     | 0    | 2     | 0 | 2                     | 1    | 0     | 0 | 0                     | 0    | 0     | 0 | 6     | 102           |
| 7:05 PM                         | 0                     | 0    | 0     | 0 | 0                     | 0    | 1     | 0 | 0                     | 1    | 2     | 0 | 0                     | 1    | 0     | 0 | 5     | 99            |
| 7:10 PM                         | 0                     | 0    | 0     | 0 | 0                     | 1    | 1     | 0 | 1                     | 3    | 1     | 0 | 0                     | 1    | 0     | 0 | 8     | 101           |
| 7:15 PM                         | 2                     | 0    | 0     | 0 | 0                     | 0    | 0     | 0 | 0                     | 2    | 1     | 0 | 0                     | 0    | 0     | 0 | 5     | 94            |
| 7:20 PM                         | 1                     | 0    | 0     | 0 | 0                     | 0    | 0     | 0 | 0                     | 1    | 0     | 0 | 0                     | 2    | 1     | 0 | 5     | 89            |
| 7:25 PM                         | 1                     | 0    | 0     | 0 | 0                     | 1    | 1     | 0 | 3                     | 1    | 0     | 0 | 0                     | 0    | 0     | 0 | 7     | 89            |
| 7:30 PM                         | 1                     | 0    | 0     | 0 | 0                     | 1    | 1     | 0 | 0                     | 0    | 3     | 0 | 0                     | 1    | 0     | 0 | 7     | 90            |
| 7:35 PM                         | 0                     | 0    | 0     | 0 | 1                     | 0    | 4     | 0 | 1                     | 1    | 3     | 0 | 0                     | 0    | 0     | 0 | 10    | 87            |
| 7:40 PM                         | 1                     | 0    | 0     | 0 | 0                     | 0    | 1     | 0 | 1                     | 1    | 0     | 0 | 0                     | 0    | 0     | 0 | 4     | 85            |
| 7:45 PM                         | 0                     | 0    | 0     | 0 | 0                     | 0    | 4     | 0 | 0                     | 1    | 0     | 0 | 0                     | 1    | 0     | 0 | 6     | 79            |
| 7:50 PM                         | 1                     | 0    | 0     | 0 | 1                     | 0    | 3     | 0 | 1                     | 0    | 1     | 0 | 0                     | 1    | 0     | 0 | 8     | 73            |
| 7:55 PM                         | 1                     | 1    | 0     | 0 | 0                     | 0    | 2     | 0 | 1                     | 0    | 5     | 0 | 0                     | 0    | 0     | 0 | 10    | 81            |
| 8:00 PM                         | 4                     | 0    | 0     | 0 | 0                     | 0    | 0     | 0 | 1                     | 0    | 1     | 0 | 0                     | 3    | 0     | 0 | 9     | 84            |
| 8:05 PM                         | 2                     | 0    | 0     | 0 | 0                     | 0    | 1     | 0 | 3                     | 2    | 0     | 0 | 1                     | 0    | 0     | 0 | 9     | 88            |
| 8:10 PM                         | 2                     | 0    | 0     | 0 | 0                     | 1    | 1     | 0 | 1                     | 4    | 4     | 0 | 0                     | 1    | 0     | 0 | 14    | 94            |
| 8:15 PM                         | 0                     | 0    | 0     | 0 | 0                     | 0    | 2     | 0 | 0                     | 2    | 1     | 0 | 0                     | 1    | 0     | 0 | 6     | 95            |
| 8:20 PM                         | 1                     | 0    | 0     | 0 | 0                     | 0    | 3     | 0 | 0                     | 1    | 0     | 0 | 0                     | 3    | 0     | 0 | 8     | 98            |
| 8:25 PM                         | 2                     | 0    | 0     | 0 | 0                     | 0    | 0     | 0 | 2                     | 0    | 1     | 0 | 0                     | 1    | 0     | 0 | 6     | 97            |
| 8:30 PM                         | 0                     | 0    | 0     | 0 | 0                     | 0    | 3     | 0 | 3                     | 1    | 0     | 0 | 0                     | 1    | 0     | 0 | 8     | 98            |
| 8:35 PM                         | 0                     | 0    | 0     | 0 | 0                     | 0    | 1     | 0 | 1                     | 0    | 2     | 0 | 0                     | 0    | 0     | 0 | 4     | 92            |
| 8:40 PM                         | 0                     | 0    | 0     | 0 | 0                     | 0    | 0     | 0 | 0                     | 0    | 1     | 0 | 0                     | 0    | 0     | 0 | 1     | 89            |
| 8:45 PM                         | 1                     | 0    | 0     | 0 | 0                     | 0    | 0     | 0 | 0                     | 3    | 1     | 0 | 0                     | 0    | 0     | 0 | 5     | 88            |
| 8:50 PM                         | 2                     | 0    | 0     | 0 | 0                     | 0    | 2     | 0 | 1                     | 2    | 0     | 0 | 0                     | 1    | 0     | 0 | 8     | 88            |
| 8:55 PM                         | 1                     | 0    | 0     | 0 | 0                     | 0    | 2     | 0 | 4                     | 1    | 1     | 0 | 0                     | 0    | 0     | 0 | 9     | 87            |
| 9:00 PM                         | 0                     | 0    | 0     | 0 | 0                     | 0    | 1     | 0 | 0                     | 1    | 2     | 0 | 0                     | 1    | 0     | 0 | 5     | 83            |
| 9:05 PM                         | 0                     | 0    | 0     | 0 | 0                     | 0    | 1     | 0 | 1                     | 0    | 1     | 0 | 0                     | 0    | 1     | 0 | 4     | 78            |
| 9:10 PM                         | 1                     | 0    | 0     | 0 | 0                     | 0    | 2     | 0 | 3                     | 0    | 0     | 0 | 0                     | 1    | 0     | 0 | 7     | 71            |
| 9:15 PM                         | 0                     | 1    | 0     | 0 | 0                     | 0    | 0     | 0 | 1                     | 2    | 1     | 0 | 0                     | 2    | 0     | 0 | 7     | 72            |
| 9:20 PM                         | 0                     | 2    | 0     | 0 | 0                     | 0    | 4     | 0 | 2                     | 2    | 0     | 0 | 0                     | 1    | 0     | 0 | 11    | 75            |
| 9:25 PM                         | 1                     | 0    | 0     | 0 | 0                     | 0    | 5     | 0 | 2                     | 1    | 1     | 0 | 0                     | 1    | 0     | 0 | 11    | 80            |
| 9:30 PM                         | 0                     | 0    | 0     | 0 | 1                     | 1    | 3     | 0 | 3                     | 1    | 1     | 0 | 0                     | 0    | 0     | 0 | 10    | 82            |
| 9:35 PM                         | 2                     | 0    | 0     | 0 | 0                     | 0    | 2     | 0 | 2                     | 0    | 1     | 0 | 0                     | 0    | 1     | 0 | 8     | 86            |
| 9:40 PM                         | 1                     | 1    | 0     | 0 | 0                     | 0    | 1     | 0 | 3                     | 0    | 0     | 0 | 0                     | 0    | 0     | 0 | 6     | 91            |
| 9:45 PM                         | 0                     | 0    | 1     | 0 | 0                     | 0    | 0     | 0 | 1                     | 0    | 1     | 0 | 0                     | 0    | 0     | 0 | 3     | 89            |
| 9:50 PM                         | 0                     | 0    | 0     | 0 | 0                     | 0    | 2     | 0 | 0                     | 0    | 2     | 0 | 0                     | 0    | 0     | 0 | 4     | 85            |
| 9:55 PM                         | 0                     | 0    | 0     | 0 | 0                     | 0    | 0     | 0 | 2                     | 1    | 2     | 0 | 0                     | 1    | 0     | 0 | 6     | 82            |
| Peak 15-Min Flowrates           | Northbound            |      |       |   | Southbound            |      |       |   | Eastbound             |      |       |   | Westbound             |      |       |   | Total |               |
|                                 | Left                  | Thru | Right | U | Left                  | Thru | Right | U | Left                  | Thru | Right | U | Left                  | Thru | Right | U |       |               |
| All Vehicles                    | 44                    | 4    | 0     | 0 | 4                     | 0    | 32    | 0 | 16                    | 36   | 8     | 0 | 0                     | 36   | 4     | 0 | 184   |               |
| Heavy Trucks                    | 0                     | 0    | 0     | 0 | 4                     | 0    | 0     | 0 | 0                     | 4    | 0     | 0 | 0                     | 0    | 0     | 0 | 8     |               |
| Buses                           |                       |      |       |   |                       |      |       |   |                       |      |       |   |                       |      |       |   |       |               |
| Pedestrians                     |                       | 0    |       |   |                       | 0    |       |   |                       | 0    |       |   |                       | 4    |       |   | 4     |               |
| Bicycles                        | 0                     | 0    | 0     |   | 0                     | 0    | 4     |   | 0                     | 0    | 0     |   | 0                     | 0    | 4     |   | 8     |               |
| Scoters                         |                       |      |       |   |                       |      |       |   |                       |      |       |   |                       |      |       |   |       |               |

Comments:

LOCATION: Kensington Rd -- Gertrude Dr  
 CITY/STATE: Rossmore, CA

QC JOB #: 16966410  
 DATE: Wed, Apr 9 2025

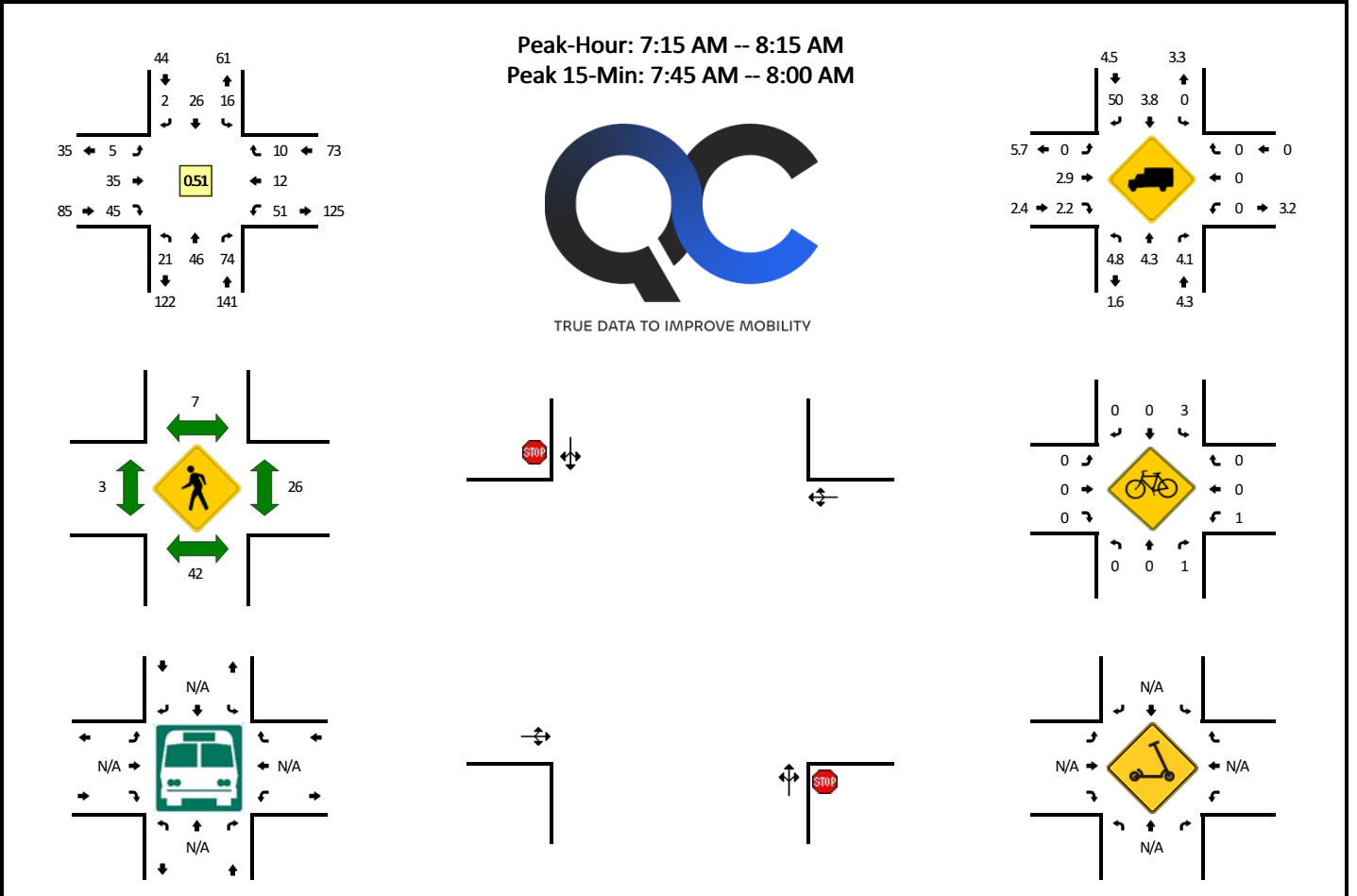

| 5-Min Count Period Beginning At | Kensington Rd (Northbound) |      |       |   | Kensington Rd (Southbound) |      |       |   | Gertrude Dr (Eastbound) |      |       |   | Gertrude Dr (Westbound) |      |       |   | Total | Hourly Totals |
|---------------------------------|----------------------------|------|-------|---|----------------------------|------|-------|---|-------------------------|------|-------|---|-------------------------|------|-------|---|-------|---------------|
|                                 | Left                       | Thru | Right | U | Left                       | Thru | Right | U | Left                    | Thru | Right | U | Left                    | Thru | Right | U |       |               |
| 6:00 AM                         | 0                          | 0    | 0     | 0 | 0                          | 0    | 0     | 0 | 0                       | 0    | 0     | 0 | 0                       | 0    | 0     | 0 | 0     | 0             |
| 6:05 AM                         | 0                          | 0    | 0     | 0 | 0                          | 0    | 0     | 0 | 0                       | 0    | 0     | 0 | 0                       | 0    | 0     | 0 | 0     | 0             |
| 6:10 AM                         | 0                          | 1    | 0     | 0 | 1                          | 1    | 0     | 0 | 0                       | 0    | 0     | 0 | 0                       | 0    | 0     | 0 | 0     | 3             |
| 6:15 AM                         | 0                          | 0    | 0     | 0 | 0                          | 0    | 0     | 0 | 0                       | 0    | 0     | 0 | 0                       | 0    | 0     | 0 | 0     | 0             |
| 6:20 AM                         | 0                          | 0    | 0     | 0 | 0                          | 0    | 0     | 0 | 0                       | 0    | 0     | 0 | 0                       | 0    | 0     | 0 | 0     | 0             |
| 6:25 AM                         | 0                          | 0    | 0     | 0 | 0                          | 0    | 0     | 0 | 0                       | 0    | 0     | 0 | 1                       | 0    | 0     | 0 | 0     | 1             |
| 6:30 AM                         | 0                          | 0    | 1     | 0 | 0                          | 0    | 0     | 0 | 0                       | 0    | 0     | 0 | 0                       | 0    | 0     | 0 | 0     | 1             |
| 6:35 AM                         | 0                          | 0    | 0     | 0 | 1                          | 0    | 0     | 0 | 0                       | 0    | 0     | 0 | 1                       | 0    | 0     | 0 | 0     | 2             |
| 6:40 AM                         | 0                          | 0    | 0     | 0 | 0                          | 0    | 0     | 0 | 0                       | 0    | 0     | 1 | 2                       | 0    | 0     | 0 | 0     | 3             |
| 6:45 AM                         | 0                          | 0    | 1     | 0 | 0                          | 0    | 0     | 0 | 0                       | 0    | 2     | 0 | 1                       | 0    | 0     | 0 | 0     | 4             |
| 6:50 AM                         | 0                          | 0    | 0     | 0 | 1                          | 0    | 0     | 0 | 0                       | 0    | 0     | 2 | 2                       | 0    | 0     | 0 | 0     | 5             |
| 6:55 AM                         | 1                          | 1    | 1     | 0 | 0                          | 1    | 0     | 0 | 0                       | 0    | 1     | 1 | 0                       | 0    | 0     | 1 | 0     | 7             |
| 7:00 AM                         | 1                          | 0    | 1     | 0 | 0                          | 3    | 0     | 0 | 0                       | 0    | 0     | 1 | 0                       | 0    | 0     | 0 | 0     | 6             |
| 7:05 AM                         | 0                          | 1    | 0     | 0 | 0                          | 1    | 0     | 0 | 0                       | 0    | 0     | 1 | 0                       | 3    | 0     | 0 | 0     | 6             |
| 7:10 AM                         | 0                          | 0    | 1     | 0 | 1                          | 0    | 0     | 0 | 0                       | 0    | 0     | 0 | 0                       | 2    | 0     | 0 | 0     | 4             |
| 7:15 AM                         | 1                          | 0    | 3     | 0 | 0                          | 1    | 0     | 0 | 0                       | 0    | 0     | 2 | 0                       | 3    | 0     | 1 | 0     | 11            |
| 7:20 AM                         | 2                          | 1    | 5     | 0 | 1                          | 1    | 2     | 0 | 0                       | 0    | 0     | 3 | 0                       | 6    | 0     | 0 | 0     | 21            |
| 7:25 AM                         | 0                          | 3    | 6     | 0 | 0                          | 2    | 0     | 0 | 0                       | 0    | 0     | 2 | 0                       | 6    | 0     | 0 | 0     | 19            |
| 7:30 AM                         | 1                          | 3    | 2     | 0 | 0                          | 3    | 0     | 0 | 0                       | 0    | 0     | 4 | 0                       | 4    | 1     | 0 | 0     | 18            |
| 7:35 AM                         | 0                          | 2    | 0     | 0 | 0                          | 2    | 0     | 0 | 0                       | 0    | 4     | 3 | 0                       | 2    | 0     | 0 | 0     | 13            |
| 7:40 AM                         | 3                          | 2    | 7     | 0 | 4                          | 3    | 0     | 0 | 0                       | 0    | 7     | 9 | 0                       | 4    | 0     | 0 | 0     | 39            |
| 7:45 AM                         | 4                          | 8    | 4     | 0 | 6                          | 3    | 0     | 0 | 0                       | 1    | 6     | 9 | 0                       | 7    | 0     | 3 | 0     | 51            |
| 7:50 AM                         | 3                          | 7    | 14    | 0 | 1                          | 5    | 0     | 0 | 0                       | 2    | 7     | 3 | 0                       | 10   | 3     | 1 | 0     | 56            |
| 7:55 AM                         | 5                          | 8    | 15    | 0 | 4                          | 5    | 0     | 0 | 0                       | 0    | 8     | 6 | 0                       | 7    | 2     | 2 | 0     | 62            |
| 8:00 AM                         | 1                          | 7    | 9     | 0 | 0                          | 0    | 0     | 0 | 0                       | 0    | 1     | 2 | 0                       | 0    | 6     | 3 | 0     | 29            |
| 8:05 AM                         | 1                          | 5    | 6     | 0 | 0                          | 1    | 0     | 0 | 0                       | 2    | 1     | 1 | 0                       | 0    | 0     | 0 | 0     | 17            |
| 8:10 AM                         | 0                          | 0    | 3     | 0 | 0                          | 0    | 0     | 0 | 0                       | 0    | 1     | 1 | 0                       | 2    | 0     | 0 | 0     | 7             |
| 8:15 AM                         | 0                          | 0    | 1     | 0 | 0                          | 0    | 0     | 0 | 0                       | 0    | 0     | 0 | 0                       | 0    | 0     | 0 | 0     | 1             |
| 8:20 AM                         | 0                          | 0    | 2     | 0 | 1                          | 0    | 0     | 0 | 0                       | 0    | 0     | 0 | 0                       | 0    | 1     | 0 | 0     | 4             |
| 8:25 AM                         | 0                          | 0    | 2     | 0 | 0                          | 0    | 0     | 0 | 0                       | 0    | 0     | 2 | 0                       | 0    | 0     | 0 | 0     | 4             |
| 8:30 AM                         | 0                          | 1    | 0     | 0 | 1                          | 0    | 0     | 0 | 0                       | 0    | 0     | 0 | 0                       | 2    | 0     | 0 | 0     | 4             |
| 8:35 AM                         | 0                          | 0    | 0     | 0 | 0                          | 1    | 0     | 0 | 0                       | 0    | 0     | 0 | 0                       | 2    | 0     | 0 | 0     | 3             |
| 8:40 AM                         | 0                          | 0    | 1     | 0 | 0                          | 0    | 0     | 0 | 0                       | 0    | 0     | 1 | 0                       | 2    | 0     | 0 | 0     | 4             |
| 8:45 AM                         | 0                          | 0    | 0     | 0 | 1                          | 1    | 0     | 0 | 0                       | 0    | 0     | 0 | 0                       | 0    | 0     | 1 | 0     | 3             |
| 8:50 AM                         | 1                          | 0    | 3     | 0 | 0                          | 1    | 0     | 0 | 0                       | 0    | 0     | 0 | 0                       | 0    | 0     | 0 | 0     | 5             |
| 8:55 AM                         | 0                          | 0    | 3     | 0 | 0                          | 0    | 0     | 0 | 0                       | 0    | 0     | 3 | 0                       | 0    | 0     | 1 | 0     | 7             |
| 9:00 AM                         | 1                          | 0    | 2     | 0 | 1                          | 0    | 0     | 0 | 0                       | 0    | 0     | 0 | 0                       | 0    | 0     | 0 | 0     | 4             |
| 9:05 AM                         | 0                          | 0    | 1     | 0 | 0                          | 0    | 0     | 0 | 0                       | 0    | 0     | 1 | 0                       | 1    | 0     | 0 | 0     | 3             |

### Attachment B

| 5-Min Count Period Beginning At | Kensington Rd (Northbound) |      |       |   | Kensington Rd (Southbound) |      |       |   | Gertrude Dr (Eastbound) |      |       |   | Gertrude Dr (Westbound) |      |       |   | Total | Hourly Totals |
|---------------------------------|----------------------------|------|-------|---|----------------------------|------|-------|---|-------------------------|------|-------|---|-------------------------|------|-------|---|-------|---------------|
|                                 | Left                       | Thru | Right | U | Left                       | Thru | Right | U | Left                    | Thru | Right | U | Left                    | Thru | Right | U |       |               |
| 9:10 AM                         | 0                          | 0    | 2     | 0 | 0                          | 0    | 0     | 0 | 0                       | 0    | 0     | 0 | 0                       | 0    | 0     | 0 | 2     | 44            |
| 9:15 AM                         | 0                          | 1    | 0     | 0 | 0                          | 1    | 0     | 0 | 0                       | 0    | 1     | 0 | 0                       | 0    | 1     | 0 | 4     | 47            |
| 9:20 AM                         | 0                          | 0    | 1     | 0 | 0                          | 1    | 0     | 0 | 0                       | 1    | 0     | 0 | 0                       | 0    | 0     | 0 | 3     | 46            |
| 9:25 AM                         | 1                          | 0    | 1     | 0 | 0                          | 0    | 0     | 0 | 0                       | 0    | 1     | 1 | 0                       | 3    | 0     | 0 | 7     | 49            |
| 9:30 AM                         | 0                          | 0    | 0     | 0 | 0                          | 0    | 0     | 0 | 0                       | 0    | 0     | 2 | 0                       | 0    | 0     | 0 | 2     | 47            |
| 9:35 AM                         | 0                          | 1    | 0     | 0 | 0                          | 0    | 0     | 0 | 0                       | 0    | 0     | 0 | 0                       | 1    | 0     | 0 | 2     | 46            |
| 9:40 AM                         | 0                          | 1    | 0     | 0 | 1                          | 0    | 0     | 0 | 0                       | 0    | 1     | 0 | 0                       | 1    | 0     | 1 | 5     | 47            |
| 9:45 AM                         | 0                          | 0    | 0     | 0 | 0                          | 0    | 0     | 0 | 0                       | 0    | 0     | 0 | 0                       | 0    | 0     | 0 | 0     | 44            |
| 9:50 AM                         | 0                          | 0    | 0     | 0 | 1                          | 1    | 0     | 0 | 0                       | 0    | 0     | 0 | 0                       | 0    | 0     | 0 | 2     | 41            |
| 9:55 AM                         | 0                          | 0    | 0     | 0 | 0                          | 0    | 0     | 0 | 0                       | 0    | 1     | 0 | 0                       | 2    | 0     | 0 | 3     | 37            |
| 10:00 AM                        | 0                          | 0    | 0     | 0 | 1                          | 0    | 0     | 0 | 0                       | 0    | 1     | 0 | 0                       | 2    | 0     | 0 | 4     | 37            |
| 10:05 AM                        | 0                          | 0    | 1     | 0 | 0                          | 0    | 0     | 0 | 0                       | 0    | 1     | 0 | 0                       | 1    | 0     | 0 | 3     | 37            |
| 10:10 AM                        | 0                          | 0    | 0     | 0 | 0                          | 0    | 0     | 0 | 0                       | 0    | 0     | 0 | 0                       | 0    | 0     | 1 | 36    |               |
| 10:15 AM                        | 0                          | 0    | 2     | 0 | 0                          | 1    | 0     | 0 | 0                       | 0    | 0     | 0 | 0                       | 1    | 0     | 0 | 4     | 36            |
| 10:20 AM                        | 0                          | 0    | 0     | 0 | 0                          | 0    | 0     | 0 | 0                       | 0    | 0     | 0 | 0                       | 0    | 0     | 0 | 0     | 33            |
| 10:25 AM                        | 0                          | 0    | 3     | 0 | 0                          | 0    | 0     | 0 | 0                       | 0    | 1     | 0 | 0                       | 0    | 0     | 0 | 4     | 30            |
| 10:30 AM                        | 0                          | 0    | 1     | 0 | 0                          | 0    | 0     | 0 | 0                       | 0    | 0     | 1 | 0                       | 2    | 0     | 1 | 5     | 33            |
| 10:35 AM                        | 0                          | 0    | 1     | 0 | 0                          | 0    | 1     | 0 | 0                       | 0    | 0     | 0 | 0                       | 0    | 0     | 0 | 2     | 33            |
| 10:40 AM                        | 0                          | 0    | 1     | 0 | 0                          | 0    | 0     | 0 | 0                       | 0    | 1     | 0 | 0                       | 1    | 0     | 0 | 3     | 31            |
| 10:45 AM                        | 0                          | 0    | 1     | 0 | 1                          | 0    | 0     | 0 | 0                       | 0    | 0     | 0 | 0                       | 0    | 1     | 0 | 3     | 34            |
| 10:50 AM                        | 0                          | 0    | 0     | 0 | 0                          | 1    | 0     | 0 | 0                       | 0    | 2     | 1 | 0                       | 0    | 1     | 1 | 6     | 38            |
| 10:55 AM                        | 1                          | 1    | 0     | 0 | 0                          | 1    | 0     | 0 | 0                       | 0    | 0     | 0 | 0                       | 0    | 0     | 0 | 3     | 38            |
| 11:00 AM                        | 0                          | 0    | 1     | 0 | 0                          | 0    | 0     | 0 | 0                       | 0    | 0     | 0 | 0                       | 0    | 0     | 0 | 1     | 35            |
| 11:05 AM                        | 0                          | 2    | 1     | 0 | 0                          | 0    | 0     | 0 | 0                       | 0    | 0     | 1 | 0                       | 1    | 0     | 0 | 5     | 37            |
| 11:10 AM                        | 0                          | 0    | 0     | 0 | 0                          | 0    | 0     | 0 | 0                       | 0    | 0     | 0 | 0                       | 0    | 0     | 0 | 0     | 36            |
| 11:15 AM                        | 0                          | 0    | 2     | 0 | 0                          | 0    | 0     | 0 | 0                       | 0    | 0     | 1 | 0                       | 2    | 0     | 0 | 5     | 37            |
| 11:20 AM                        | 0                          | 1    | 0     | 0 | 0                          | 1    | 0     | 0 | 0                       | 0    | 0     | 0 | 0                       | 2    | 0     | 0 | 4     | 41            |
| 11:25 AM                        | 0                          | 1    | 0     | 0 | 0                          | 1    | 0     | 0 | 0                       | 0    | 0     | 0 | 0                       | 2    | 0     | 0 | 4     | 41            |
| 11:30 AM                        | 0                          | 0    | 2     | 0 | 0                          | 0    | 0     | 0 | 0                       | 0    | 0     | 1 | 0                       | 0    | 1     | 0 | 4     | 40            |
| 11:35 AM                        | 0                          | 0    | 1     | 0 | 0                          | 1    | 0     | 0 | 0                       | 0    | 0     | 0 | 0                       | 1    | 0     | 0 | 3     | 41            |
| 11:40 AM                        | 1                          | 0    | 0     | 0 | 0                          | 0    | 0     | 0 | 0                       | 0    | 0     | 0 | 0                       | 1    | 1     | 0 | 3     | 41            |
| 11:45 AM                        | 0                          | 0    | 0     | 0 | 0                          | 0    | 0     | 0 | 0                       | 0    | 0     | 0 | 0                       | 1    | 0     | 0 | 1     | 39            |
| 11:50 AM                        | 0                          | 0    | 1     | 0 | 0                          | 0    | 0     | 0 | 0                       | 0    | 1     | 0 | 0                       | 1    | 0     | 0 | 3     | 36            |
| 11:55 AM                        | 0                          | 1    | 2     | 0 | 1                          | 0    | 1     | 0 | 0                       | 0    | 0     | 0 | 0                       | 0    | 1     | 0 | 6     | 39            |
| 12:00 PM                        | 0                          | 0    | 1     | 0 | 1                          | 0    | 0     | 0 | 0                       | 0    | 0     | 0 | 0                       | 0    | 0     | 1 | 3     | 41            |
| 12:05 PM                        | 0                          | 0    | 0     | 0 | 0                          | 0    | 0     | 0 | 0                       | 0    | 1     | 0 | 0                       | 1    | 0     | 0 | 2     | 38            |
| 12:10 PM                        | 0                          | 1    | 1     | 0 | 0                          | 1    | 0     | 0 | 0                       | 0    | 0     | 0 | 0                       | 1    | 0     | 0 | 4     | 42            |
| 12:15 PM                        | 0                          | 1    | 1     | 0 | 0                          | 0    | 0     | 0 | 0                       | 0    | 0     | 0 | 0                       | 1    | 0     | 0 | 3     | 40            |
| 12:20 PM                        | 3                          | 0    | 0     | 0 | 0                          | 0    | 0     | 0 | 0                       | 0    | 0     | 0 | 0                       | 2    | 0     | 3 | 8     | 44            |
| 12:25 PM                        | 0                          | 0    | 0     | 0 | 1                          | 1    | 0     | 0 | 0                       | 0    | 0     | 0 | 0                       | 1    | 0     | 1 | 4     | 44            |
| 12:30 PM                        | 0                          | 0    | 1     | 0 | 1                          | 0    | 0     | 0 | 0                       | 0    | 0     | 1 | 0                       | 1    | 1     | 0 | 5     | 45            |
| 12:35 PM                        | 0                          | 0    | 2     | 0 | 0                          | 2    | 0     | 0 | 0                       | 0    | 2     | 1 | 0                       | 1    | 0     | 0 | 8     | 50            |
| 12:40 PM                        | 0                          | 0    | 0     | 0 | 0                          | 0    | 0     | 0 | 0                       | 0    | 1     | 0 | 0                       | 1    | 0     | 1 | 3     | 50            |
| 12:45 PM                        | 0                          | 0    | 2     | 0 | 0                          | 3    | 1     | 0 | 0                       | 0    | 0     | 0 | 0                       | 2    | 1     | 2 | 11    | 60            |
| 12:50 PM                        | 1                          | 0    | 0     | 0 | 1                          | 0    | 0     | 0 | 0                       | 0    | 3     | 0 | 0                       | 7    | 0     | 0 | 12    | 69            |
| 12:55 PM                        | 0                          | 0    | 0     | 0 | 0                          | 1    | 0     | 0 | 0                       | 0    | 1     | 0 | 0                       | 4    | 0     | 0 | 6     | 69            |
| 1:00 PM                         | 0                          | 0    | 0     | 0 | 3                          | 3    | 0     | 0 | 0                       | 0    | 1     | 1 | 0                       | 3    | 0     | 0 | 11    | 77            |
| 1:05 PM                         | 1                          | 2    | 1     | 0 | 0                          | 1    | 0     | 0 | 0                       | 0    | 0     | 2 | 0                       | 4    | 0     | 0 | 11    | 86            |
| 1:10 PM                         | 0                          | 1    | 1     | 0 | 0                          | 2    | 0     | 0 | 0                       | 0    | 5     | 1 | 0                       | 3    | 1     | 1 | 15    | 97            |
| 1:15 PM                         | 3                          | 1    | 4     | 0 | 1                          | 2    | 0     | 0 | 0                       | 0    | 6     | 2 | 0                       | 6    | 1     | 1 | 27    | 121           |
| 1:20 PM                         | 1                          | 1    | 6     | 0 | 2                          | 0    | 1     | 0 | 0                       | 0    | 3     | 3 | 0                       | 5    | 0     | 0 | 22    | 135           |
| 1:25 PM                         | 4                          | 6    | 6     | 0 | 2                          | 0    | 1     | 0 | 0                       | 0    | 7     | 0 | 0                       | 2    | 1     | 1 | 30    | 161           |
| 1:30 PM                         | 3                          | 11   | 8     | 0 | 1                          | 0    | 0     | 0 | 0                       | 1    | 3     | 2 | 0                       | 3    | 3     | 3 | 38    | 194           |
| 1:35 PM                         | 3                          | 6    | 8     | 0 | 0                          | 0    | 0     | 0 | 0                       | 0    | 2     | 0 | 0                       | 2    | 1     | 0 | 22    | 208           |
| 1:40 PM                         | 2                          | 2    | 5     | 0 | 1                          | 1    | 1     | 0 | 0                       | 0    | 0     | 0 | 0                       | 0    | 0     | 1 | 13    | 218           |
| 1:45 PM                         | 1                          | 0    | 3     | 0 | 0                          | 0    | 0     | 0 | 0                       | 0    | 1     | 0 | 0                       | 1    | 1     | 0 | 7     | 214           |
| 1:50 PM                         | 0                          | 2    | 3     | 0 | 0                          | 0    | 0     | 0 | 0                       | 0    | 0     | 0 | 0                       | 0    | 0     | 0 | 5     | 207           |
| 1:55 PM                         | 1                          | 0    | 2     | 0 | 0                          | 0    | 0     | 0 | 0                       | 1    | 1     | 1 | 0                       | 1    | 0     | 1 | 8     | 209           |
| 2:00 PM                         | 1                          | 3    | 2     | 0 | 1                          | 2    | 0     | 0 | 0                       | 0    | 0     | 0 | 0                       | 1    | 1     | 0 | 11    | 209           |
| 2:05 PM                         | 0                          | 2    | 1     | 0 | 0                          | 1    | 0     | 0 | 0                       | 0    | 0     | 0 | 0                       | 1    | 0     | 0 | 5     | 203           |
| 2:10 PM                         | 0                          | 0    | 2     | 0 | 1                          | 0    | 0     | 0 | 0                       | 0    | 0     | 1 | 0                       | 1    | 0     | 0 | 5     | 193           |
| 2:15 PM                         | 1                          | 1    | 0     | 0 | 0                          | 0    | 1     | 0 | 0                       | 0    | 0     | 1 | 0                       | 0    | 0     | 1 | 5     | 171           |
| 2:20 PM                         | 0                          | 1    | 2     | 0 | 0                          | 0    | 0     | 0 | 0                       | 1    | 0     | 0 | 0                       | 2    | 0     | 0 | 6     | 155           |
| 2:25 PM                         | 1                          | 1    | 1     | 0 | 0                          | 0    | 0     | 0 | 0                       | 0    | 0     | 0 | 0                       | 2    | 0     | 0 | 5     | 130           |
| 2:30 PM                         | 2                          | 1    | 3     | 0 | 0                          | 2    | 0     | 0 | 0                       | 0    | 0     | 0 | 0                       | 1    | 2     | 0 | 11    | 103           |
| 2:35 PM                         | 2                          | 1    | 5     | 0 | 0                          | 2    | 0     | 0 | 0                       | 1    | 1     | 3 | 0                       | 4    | 0     | 0 | 19    | 100           |
| 2:40 PM                         | 2                          | 0    | 1     | 0 | 1                          | 0    | 0     | 0 | 0                       | 0    | 1     | 2 | 0                       | 3    | 1     | 0 | 11    | 98            |
| 2:45 PM                         | 0                          | 0    | 6     | 0 | 0                          | 4    | 0     | 0 | 0                       | 0    | 1     | 0 | 0                       | 3    | 1     | 0 | 15    | 106           |
| 2:50 PM                         | 2                          | 4    | 8     | 0 | 0                          | 0    | 0     | 0 | 0                       | 0    | 0     | 3 | 0                       | 1    | 0     | 0 | 18    | 119           |
| 2:55 PM                         | 3                          | 4    | 5     | 0 | 0                          | 0    | 0     | 0 | 0                       | 0    | 1     | 4 | 0                       | 0    | 0     | 1 | 18    | 129           |
| 3:00 PM                         | 1                          | 1    | 2     | 0 | 0                          | 0    | 0     | 0 | 0                       | 0    | 0     | 0 | 0                       | 0    | 0     | 0 | 4     | 122           |
| 3:05 PM                         | 1                          | 2    | 6     | 0 | 0                          | 1    | 0     | 0 | 0                       | 0    | 1     | 0 | 0                       | 3    | 0     | 0 | 14    | 131           |
| 3:10 PM                         | 0                          | 0    | 4     | 0 | 1                          | 0    | 0     | 0 | 0                       | 0    | 1     | 1 | 0                       | 0    | 1     | 0 | 8     | 134           |
| 3:15 PM                         | 0                          | 0    | 5     | 0 | 0                          | 0    | 0     | 0 | 0                       | 0    | 0     | 0 | 0                       | 0    | 2     | 0 | 7     | 136           |
| 3:20 PM                         | 0                          | 1    | 3     | 0 | 0                          | 0    | 0     | 0 | 0                       | 0    | 0     | 0 | 0                       | 0    | 0     | 1 | 5     | 135           |
| 3:25 PM                         | 0                          | 0    | 0     | 0 | 0                          | 1    | 0     | 0 | 0                       | 0    | 0     | 1 | 0                       | 0    | 0     | 0 | 2     | 132           |
| 3:30 PM                         | 0                          | 0    | 1     | 0 | 1                          | 1    | 0     | 0 | 0                       | 0    | 0     | 0 | 0                       | 0    | 2     | 0 | 5     | 126           |
| 3:35 PM                         | 0                          | 2    | 2     | 0 | 0                          | 0    | 1     | 0 | 0                       | 0    | 0     | 0 | 0                       | 0    | 0     | 0 | 5     | 112           |
| 3:40 PM                         | 0                          | 0    | 0     | 0 | 0                          | 0    | 0     | 0 | 0                       | 0    | 0     | 1 | 0                       | 2    | 1     | 0 | 4     | 105           |
| 3:45 PM                         | 1                          | 1    | 1     | 0 | 1                          | 0    | 0     | 0 | 0                       | 0    | 0     | 0 | 0                       | 3    | 0     | 0 | 7     | 97            |
| 3:50 PM                         | 0                          | 1    | 2     | 0 | 0                          | 3    | 1     | 0 | 0                       | 0    | 0     | 0 | 0                       | 2    | 0     | 0 | 9     | 88            |
| 3:55 PM                         | 1                          | 0    | 4     | 0 | 1                          | 0    | 0     | 0 | 0                       | 0    | 1     | 1 | 0                       | 2    | 0     | 0 | 10    | 80            |
| 4:00 PM                         | 1                          | 0    | 3     | 0 | 1                          | 0    | 0     | 0 | 0                       | 0    | 0     | 2 | 0                       | 1    | 0     | 2 | 10    | 86            |
| 4:05 PM                         | 0                          | 0    | 7     | 0 | 0                          | 1    | 0     | 0 | 0                       | 0    | 0     | 0 | 0                       | 2    | 0     | 0 | 10    | 82            |
| 4:10 PM                         | 0                          | 1    | 3     | 0 | 1                          | 0    | 0     | 0 | 0                       | 0    | 0     | 0 | 0                       | 0    | 1     | 0 | 6     | 80            |
| 4:15 PM                         | 0                          | 0    | 1     | 0 | 2                          | 1    | 0     | 0 | 0                       | 0    | 0     | 0 | 0                       | 1    | 1     | 0 | 6     | 79            |
| 4:20 PM                         | 0                          | 1    | 3     | 0 | 0                          | 0    | 0     | 0 | 0                       | 0    | 0     | 0 | 0                       | 3    | 1     | 3 | 11    | 85            |
| 4:25 PM                         | 0                          | 2    | 1     | 0 | 0                          | 0    | 1     | 0 | 0                       | 0    | 0     | 1 | 0                       | 0    | 0     | 0 | 5     | 88            |
| 4:30 PM                         | 0                          | 0    | 0     | 0 | 1                          | 0    | 0     | 0 | 0                       | 0    | 0     | 0 | 0                       | 2    | 0     | 0 | 3     | 86            |

**Attachment B**

| 5-Min Count Period Beginning At | Kensington Rd (Northbound) |      |       |   | Kensington Rd (Southbound) |      |       |   | Gertrude Dr (Eastbound) |      |       |   | Gertrude Dr (Westbound) |      |       |   | Total | Hourly Totals |
|---------------------------------|----------------------------|------|-------|---|----------------------------|------|-------|---|-------------------------|------|-------|---|-------------------------|------|-------|---|-------|---------------|
|                                 | Left                       | Thru | Right | U | Left                       | Thru | Right | U | Left                    | Thru | Right | U | Left                    | Thru | Right | U |       |               |
| 4:35 PM                         | 0                          | 2    | 5     | 0 | 0                          | 0    | 0     | 0 | 0                       | 0    | 0     | 0 | 4                       | 0    | 0     | 0 | 11    | 92            |
| 4:40 PM                         | 0                          | 0    | 2     | 0 | 0                          | 0    | 0     | 0 | 0                       | 0    | 1     | 0 | 0                       | 0    | 1     | 0 | 4     | 92            |
| 4:45 PM                         | 0                          | 0    | 3     | 0 | 0                          | 0    | 0     | 0 | 1                       | 0    | 0     | 0 | 3                       | 1    | 0     | 0 | 8     | 93            |
| 4:50 PM                         | 0                          | 0    | 1     | 0 | 1                          | 0    | 0     | 0 | 0                       | 1    | 1     | 0 | 1                       | 0    | 0     | 0 | 5     | 89            |
| 4:55 PM                         | 2                          | 1    | 3     | 0 | 0                          | 0    | 0     | 0 | 0                       | 1    | 0     | 0 | 3                       | 0    | 0     | 0 | 10    | 89            |
| 5:00 PM                         | 0                          | 0    | 4     | 0 | 0                          | 0    | 0     | 0 | 1                       | 0    | 0     | 0 | 1                       | 0    | 0     | 0 | 6     | 85            |
| 5:05 PM                         | 0                          | 0    | 1     | 0 | 0                          | 0    | 0     | 0 | 0                       | 1    | 0     | 0 | 0                       | 1    | 0     | 0 | 3     | 78            |
| 5:10 PM                         | 0                          | 1    | 2     | 0 | 0                          | 0    | 0     | 0 | 0                       | 0    | 0     | 0 | 0                       | 0    | 0     | 0 | 3     | 75            |
| 5:15 PM                         | 0                          | 0    | 1     | 0 | 0                          | 2    | 0     | 0 | 0                       | 0    | 0     | 0 | 0                       | 0    | 0     | 0 | 3     | 72            |
| 5:20 PM                         | 1                          | 0    | 0     | 0 | 0                          | 0    | 0     | 0 | 0                       | 0    | 0     | 0 | 1                       | 0    | 1     | 0 | 3     | 64            |
| 5:25 PM                         | 1                          | 0    | 2     | 0 | 0                          | 0    | 0     | 0 | 0                       | 0    | 0     | 0 | 1                       | 0    | 1     | 0 | 5     | 64            |
| 5:30 PM                         | 0                          | 0    | 0     | 0 | 0                          | 0    | 0     | 0 | 0                       | 1    | 0     | 0 | 1                       | 2    | 1     | 0 | 5     | 66            |
| 5:35 PM                         | 0                          | 1    | 0     | 0 | 0                          | 0    | 0     | 0 | 0                       | 0    | 0     | 0 | 0                       | 2    | 0     | 0 | 3     | 58            |
| 5:40 PM                         | 1                          | 0    | 0     | 0 | 0                          | 0    | 0     | 0 | 0                       | 0    | 0     | 0 | 0                       | 0    | 0     | 0 | 1     | 55            |
| 5:45 PM                         | 0                          | 1    | 0     | 0 | 0                          | 0    | 0     | 0 | 0                       | 0    | 1     | 0 | 0                       | 0    | 0     | 0 | 2     | 49            |
| 5:50 PM                         | 0                          | 2    | 2     | 0 | 0                          | 0    | 0     | 0 | 0                       | 1    | 0     | 0 | 0                       | 0    | 0     | 0 | 5     | 49            |
| 5:55 PM                         | 0                          | 0    | 1     | 0 | 0                          | 0    | 0     | 0 | 0                       | 0    | 0     | 0 | 0                       | 0    | 0     | 0 | 1     | 40            |
| 6:00 PM                         | 0                          | 1    | 1     | 0 | 0                          | 0    | 0     | 0 | 0                       | 1    | 0     | 0 | 1                       | 1    | 0     | 0 | 5     | 39            |
| 6:05 PM                         | 1                          | 0    | 0     | 0 | 0                          | 0    | 0     | 0 | 1                       | 0    | 1     | 0 | 0                       | 0    | 0     | 0 | 3     | 39            |
| 6:10 PM                         | 0                          | 0    | 0     | 0 | 1                          | 0    | 0     | 0 | 0                       | 0    | 0     | 0 | 1                       | 0    | 0     | 0 | 2     | 38            |
| 6:15 PM                         | 0                          | 0    | 0     | 0 | 0                          | 0    | 0     | 0 | 0                       | 2    | 0     | 0 | 0                       | 0    | 0     | 0 | 2     | 37            |
| 6:20 PM                         | 0                          | 1    | 0     | 0 | 0                          | 0    | 0     | 0 | 0                       | 0    | 0     | 0 | 0                       | 0    | 0     | 0 | 1     | 35            |
| 6:25 PM                         | 1                          | 0    | 0     | 0 | 0                          | 0    | 0     | 0 | 0                       | 0    | 0     | 0 | 0                       | 1    | 0     | 0 | 2     | 32            |
| 6:30 PM                         | 0                          | 0    | 0     | 0 | 0                          | 0    | 0     | 0 | 0                       | 0    | 0     | 0 | 0                       | 0    | 0     | 0 | 0     | 27            |
| 6:35 PM                         | 0                          | 0    | 0     | 0 | 1                          | 0    | 0     | 0 | 0                       | 1    | 0     | 0 | 0                       | 0    | 0     | 0 | 2     | 26            |
| 6:40 PM                         | 0                          | 0    | 0     | 0 | 0                          | 0    | 0     | 0 | 0                       | 1    | 0     | 0 | 0                       | 0    | 1     | 0 | 2     | 27            |
| 6:45 PM                         | 0                          | 0    | 0     | 0 | 0                          | 0    | 0     | 0 | 0                       | 0    | 0     | 0 | 1                       | 0    | 0     | 0 | 1     | 26            |
| 6:50 PM                         | 0                          | 0    | 0     | 0 | 0                          | 0    | 0     | 0 | 0                       | 1    | 0     | 0 | 0                       | 0    | 0     | 0 | 1     | 22            |
| 6:55 PM                         | 0                          | 0    | 0     | 0 | 0                          | 0    | 0     | 0 | 0                       | 0    | 0     | 0 | 0                       | 1    | 0     | 0 | 1     | 22            |
| 7:00 PM                         | 0                          | 0    | 0     | 0 | 0                          | 0    | 0     | 0 | 0                       | 0    | 0     | 0 | 0                       | 2    | 0     | 0 | 2     | 19            |
| 7:05 PM                         | 1                          | 0    | 0     | 0 | 0                          | 0    | 0     | 0 | 0                       | 1    | 0     | 0 | 1                       | 1    | 0     | 0 | 4     | 20            |
| 7:10 PM                         | 0                          | 0    | 0     | 0 | 0                          | 0    | 0     | 0 | 0                       | 1    | 0     | 0 | 0                       | 0    | 0     | 0 | 1     | 19            |
| 7:15 PM                         | 0                          | 0    | 0     | 0 | 0                          | 1    | 0     | 0 | 0                       | 1    | 0     | 0 | 0                       | 0    | 0     | 0 | 2     | 19            |
| 7:20 PM                         | 0                          | 0    | 0     | 0 | 0                          | 0    | 0     | 0 | 1                       | 0    | 0     | 0 | 0                       | 1    | 0     | 0 | 2     | 20            |
| 7:25 PM                         | 0                          | 0    | 1     | 0 | 0                          | 0    | 0     | 0 | 0                       | 0    | 0     | 0 | 0                       | 0    | 0     | 0 | 1     | 19            |
| 7:30 PM                         | 0                          | 0    | 0     | 0 | 0                          | 0    | 0     | 0 | 0                       | 1    | 0     | 0 | 0                       | 1    | 0     | 0 | 2     | 21            |
| 7:35 PM                         | 0                          | 0    | 0     | 0 | 0                          | 0    | 0     | 0 | 0                       | 0    | 1     | 0 | 0                       | 0    | 1     | 0 | 2     | 21            |
| 7:40 PM                         | 1                          | 0    | 0     | 0 | 0                          | 0    | 0     | 0 | 0                       | 0    | 0     | 0 | 0                       | 0    | 0     | 0 | 1     | 20            |
| 7:45 PM                         | 0                          | 0    | 0     | 0 | 0                          | 0    | 0     | 0 | 0                       | 0    | 0     | 0 | 0                       | 2    | 0     | 0 | 2     | 21            |
| 7:50 PM                         | 0                          | 0    | 0     | 0 | 0                          | 1    | 0     | 0 | 0                       | 0    | 0     | 0 | 0                       | 0    | 0     | 0 | 1     | 21            |
| 7:55 PM                         | 0                          | 0    | 0     | 0 | 0                          | 0    | 0     | 0 | 0                       | 0    | 0     | 0 | 0                       | 0    | 0     | 0 | 0     | 20            |
| 8:00 PM                         | 0                          | 0    | 0     | 0 | 0                          | 0    | 0     | 0 | 0                       | 0    | 0     | 0 | 0                       | 0    | 0     | 0 | 0     | 18            |
| 8:05 PM                         | 0                          | 0    | 0     | 0 | 0                          | 0    | 0     | 0 | 0                       | 1    | 0     | 0 | 0                       | 0    | 0     | 0 | 1     | 15            |
| 8:10 PM                         | 0                          | 0    | 1     | 0 | 0                          | 0    | 0     | 0 | 0                       | 0    | 0     | 0 | 0                       | 0    | 0     | 0 | 1     | 15            |
| 8:15 PM                         | 0                          | 0    | 0     | 0 | 0                          | 0    | 0     | 0 | 0                       | 0    | 0     | 0 | 1                       | 0    | 0     | 0 | 1     | 14            |
| 8:20 PM                         | 0                          | 0    | 0     | 0 | 0                          | 0    | 0     | 0 | 0                       | 0    | 0     | 0 | 0                       | 0    | 0     | 0 | 0     | 12            |
| 8:25 PM                         | 0                          | 0    | 0     | 0 | 0                          | 0    | 0     | 0 | 0                       | 0    | 0     | 0 | 0                       | 0    | 0     | 0 | 0     | 11            |
| 8:30 PM                         | 0                          | 0    | 0     | 0 | 0                          | 0    | 0     | 0 | 0                       | 0    | 0     | 0 | 0                       | 0    | 0     | 0 | 0     | 9             |
| 8:35 PM                         | 0                          | 0    | 0     | 0 | 0                          | 0    | 0     | 0 | 0                       | 0    | 0     | 0 | 0                       | 1    | 0     | 0 | 1     | 8             |
| 8:40 PM                         | 0                          | 0    | 0     | 0 | 0                          | 0    | 0     | 0 | 0                       | 0    | 0     | 0 | 0                       | 0    | 1     | 0 | 1     | 8             |
| 8:45 PM                         | 0                          | 0    | 0     | 0 | 0                          | 0    | 0     | 0 | 0                       | 1    | 0     | 0 | 0                       | 0    | 0     | 0 | 1     | 7             |
| 8:50 PM                         | 0                          | 0    | 0     | 0 | 0                          | 0    | 0     | 0 | 0                       | 1    | 0     | 0 | 0                       | 0    | 0     | 0 | 1     | 7             |
| 8:55 PM                         | 0                          | 0    | 0     | 0 | 0                          | 0    | 0     | 0 | 0                       | 0    | 0     | 0 | 0                       | 0    | 1     | 0 | 1     | 8             |
| 9:00 PM                         | 0                          | 0    | 0     | 0 | 0                          | 0    | 0     | 0 | 0                       | 0    | 0     | 0 | 0                       | 0    | 1     | 0 | 1     | 9             |
| 9:05 PM                         | 0                          | 0    | 0     | 0 | 0                          | 0    | 0     | 0 | 0                       | 0    | 0     | 0 | 0                       | 0    | 0     | 0 | 0     | 8             |
| 9:10 PM                         | 0                          | 0    | 0     | 0 | 0                          | 0    | 0     | 0 | 0                       | 0    | 0     | 0 | 0                       | 1    | 0     | 0 | 1     | 8             |
| 9:15 PM                         | 0                          | 0    | 0     | 0 | 0                          | 0    | 0     | 0 | 0                       | 0    | 0     | 0 | 0                       | 0    | 0     | 0 | 0     | 7             |
| 9:20 PM                         | 0                          | 0    | 0     | 0 | 0                          | 0    | 0     | 0 | 0                       | 0    | 0     | 0 | 0                       | 0    | 0     | 0 | 0     | 7             |
| 9:25 PM                         | 0                          | 0    | 0     | 0 | 0                          | 0    | 0     | 0 | 0                       | 1    | 0     | 0 | 0                       | 1    | 0     | 0 | 2     | 9             |
| 9:30 PM                         | 0                          | 0    | 0     | 0 | 0                          | 0    | 0     | 0 | 0                       | 0    | 0     | 0 | 0                       | 0    | 0     | 0 | 0     | 9             |
| 9:35 PM                         | 0                          | 0    | 0     | 0 | 0                          | 0    | 0     | 0 | 0                       | 0    | 0     | 0 | 0                       | 1    | 0     | 0 | 1     | 9             |
| 9:40 PM                         | 0                          | 0    | 0     | 0 | 0                          | 0    | 0     | 0 | 0                       | 0    | 1     | 0 | 0                       | 0    | 0     | 0 | 1     | 9             |
| 9:45 PM                         | 0                          | 0    | 0     | 0 | 1                          | 0    | 0     | 0 | 0                       | 0    | 0     | 0 | 0                       | 0    | 0     | 0 | 1     | 9             |
| 9:50 PM                         | 0                          | 0    | 0     | 0 | 0                          | 0    | 0     | 0 | 0                       | 0    | 0     | 0 | 0                       | 0    | 1     | 0 | 1     | 9             |
| 9:55 PM                         | 0                          | 0    | 0     | 0 | 0                          | 0    | 0     | 0 | 0                       | 0    | 0     | 0 | 0                       | 0    | 0     | 0 | 0     | 8             |
| Peak 15-Min Flowrates           | Northbound                 |      |       |   | Southbound                 |      |       |   | Eastbound               |      |       |   | Westbound               |      |       |   | Total |               |
|                                 | Left                       | Thru | Right | U | Left                       | Thru | Right | U | Left                    | Thru | Right | U | Left                    | Thru | Right | U |       |               |
| All Vehicles                    | 48                         | 92   | 132   | 0 | 44                         | 52   | 0     | 0 | 12                      | 84   | 72    | 0 | 96                      | 20   | 24    | 0 | 676   |               |
| Heavy Trucks                    | 0                          | 4    | 0     |   | 0                          | 4    | 0     |   | 0                       | 4    | 0     |   | 0                       | 0    | 0     |   | 12    |               |
| Buses                           |                            | 96   |       |   |                            | 24   |       |   |                         | 0    |       |   |                         | 68   |       |   | 188   |               |
| Pedestrians                     |                            |      | 4     |   | 12                         | 0    | 0     |   | 0                       | 0    | 0     |   | 4                       | 0    | 0     |   | 20    |               |
| Bicycles                        |                            |      |       |   |                            |      |       |   |                         |      |       |   |                         |      |       |   |       |               |
| Scoters                         |                            |      |       |   |                            |      |       |   |                         |      |       |   |                         |      |       |   |       |               |

Comments:

LOCATION: Wembley Rd -- Piedmont Ave  
 CITY/STATE: Rossmoor, CA

QC JOB #: 16966411  
 DATE: Wed, Apr 9 2025

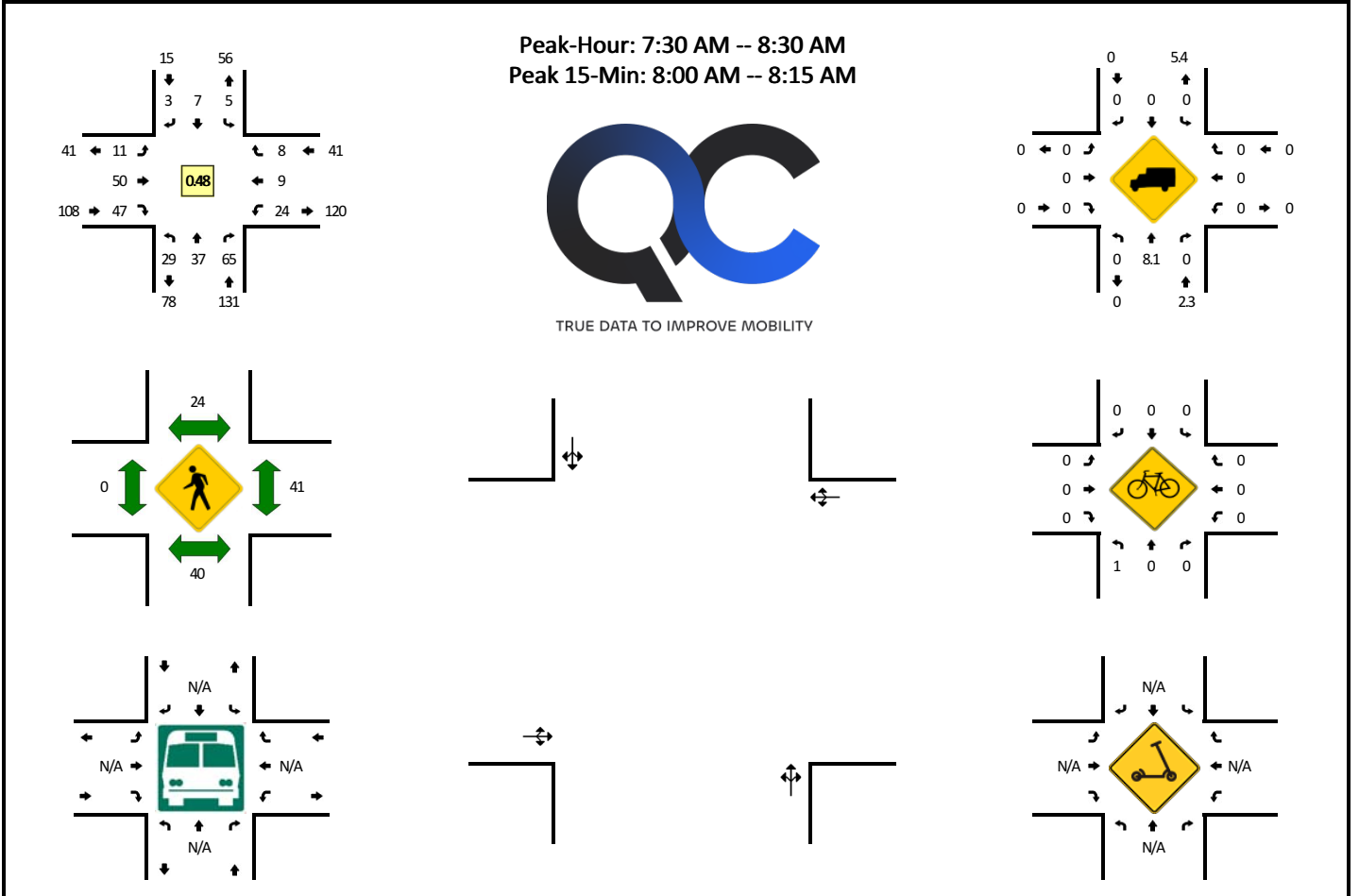

| 5-Min Count Period Beginning At | Wembley Rd (Northbound) |      |       |   | Wembley Rd (Southbound) |      |       |   | Piedmont Ave (Eastbound) |      |       |   | Piedmont Ave (Westbound) |      |       |   | Total | Hourly Totals |
|---------------------------------|-------------------------|------|-------|---|-------------------------|------|-------|---|--------------------------|------|-------|---|--------------------------|------|-------|---|-------|---------------|
|                                 | Left                    | Thru | Right | U | Left                    | Thru | Right | U | Left                     | Thru | Right | U | Left                     | Thru | Right | U |       |               |
| 6:00 AM                         | 0                       | 0    | 0     | 0 | 0                       | 0    | 0     | 0 | 0                        | 0    | 0     | 0 | 0                        | 0    | 0     | 0 | 0     |               |
| 6:05 AM                         | 0                       | 0    | 0     | 0 | 0                       | 0    | 1     | 0 | 0                        | 0    | 1     | 0 | 0                        | 0    | 0     | 0 | 2     |               |
| 6:10 AM                         | 0                       | 0    | 0     | 0 | 0                       | 0    | 0     | 0 | 0                        | 0    | 0     | 0 | 0                        | 0    | 0     | 0 | 0     |               |
| 6:15 AM                         | 0                       | 0    | 0     | 0 | 0                       | 0    | 0     | 0 | 0                        | 0    | 0     | 1 | 0                        | 0    | 0     | 0 | 2     |               |
| 6:20 AM                         | 1                       | 0    | 0     | 0 | 0                       | 0    | 0     | 0 | 0                        | 0    | 0     | 0 | 0                        | 0    | 0     | 0 | 1     |               |
| 6:25 AM                         | 0                       | 0    | 0     | 0 | 0                       | 0    | 0     | 0 | 0                        | 0    | 1     | 0 | 0                        | 0    | 0     | 0 | 1     |               |
| 6:30 AM                         | 0                       | 1    | 0     | 0 | 0                       | 0    | 0     | 0 | 0                        | 0    | 1     | 1 | 0                        | 0    | 0     | 0 | 3     |               |
| 6:35 AM                         | 0                       | 0    | 0     | 0 | 0                       | 0    | 0     | 0 | 0                        | 0    | 0     | 0 | 0                        | 1    | 0     | 0 | 1     |               |
| 6:40 AM                         | 0                       | 0    | 0     | 0 | 0                       | 0    | 0     | 0 | 0                        | 0    | 2     | 0 | 0                        | 2    | 0     | 0 | 4     |               |
| 6:45 AM                         | 0                       | 0    | 0     | 0 | 0                       | 0    | 0     | 0 | 0                        | 0    | 0     | 0 | 0                        | 1    | 0     | 0 | 1     |               |
| 6:50 AM                         | 0                       | 0    | 0     | 0 | 0                       | 0    | 0     | 0 | 0                        | 0    | 2     | 0 | 0                        | 0    | 1     | 0 | 3     |               |
| 6:55 AM                         | 0                       | 0    | 0     | 0 | 0                       | 0    | 0     | 0 | 0                        | 0    | 1     | 0 | 0                        | 0    | 0     | 0 | 1     |               |
| 7:00 AM                         | 0                       | 0    | 0     | 0 | 0                       | 0    | 0     | 0 | 0                        | 0    | 1     | 0 | 0                        | 2    | 0     | 0 | 3     |               |
| 7:05 AM                         | 0                       | 0    | 1     | 0 | 0                       | 0    | 0     | 0 | 0                        | 0    | 2     | 2 | 0                        | 1    | 0     | 0 | 6     |               |
| 7:10 AM                         | 0                       | 0    | 4     | 0 | 0                       | 1    | 1     | 0 | 0                        | 0    | 0     | 0 | 0                        | 2    | 2     | 1 | 11    |               |
| 7:15 AM                         | 0                       | 0    | 1     | 0 | 0                       | 0    | 0     | 0 | 0                        | 0    | 0     | 0 | 0                        | 2    | 0     | 0 | 3     |               |
| 7:20 AM                         | 0                       | 0    | 3     | 0 | 0                       | 0    | 0     | 0 | 0                        | 0    | 0     | 0 | 0                        | 1    | 0     | 0 | 4     |               |
| 7:25 AM                         | 0                       | 1    | 2     | 0 | 0                       | 0    | 0     | 0 | 0                        | 0    | 0     | 0 | 0                        | 0    | 0     | 0 | 3     |               |
| 7:30 AM                         | 0                       | 0    | 1     | 0 | 1                       | 0    | 0     | 0 | 0                        | 0    | 1     | 4 | 0                        | 2    | 0     | 0 | 9     |               |
| 7:35 AM                         | 1                       | 1    | 1     | 0 | 1                       | 1    | 0     | 0 | 0                        | 0    | 1     | 3 | 0                        | 0    | 0     | 0 | 9     |               |
| 7:40 AM                         | 0                       | 1    | 4     | 0 | 0                       | 1    | 0     | 0 | 0                        | 0    | 3     | 3 | 0                        | 2    | 0     | 0 | 14    |               |
| 7:45 AM                         | 0                       | 1    | 1     | 0 | 1                       | 1    | 0     | 0 | 0                        | 0    | 4     | 8 | 0                        | 0    | 0     | 0 | 16    |               |
| 7:50 AM                         | 1                       | 2    | 4     | 0 | 0                       | 0    | 0     | 0 | 0                        | 0    | 6     | 5 | 0                        | 4    | 2     | 0 | 24    |               |
| 7:55 AM                         | 8                       | 3    | 5     | 0 | 0                       | 0    | 0     | 0 | 0                        | 0    | 9     | 7 | 0                        | 4    | 2     | 0 | 38    |               |
| 8:00 AM                         | 6                       | 7    | 9     | 0 | 0                       | 0    | 0     | 0 | 4                        | 11   | 5     | 0 | 3                        | 0    | 2     | 0 | 47    |               |
| 8:05 AM                         | 8                       | 11   | 8     | 0 | 1                       | 3    | 1     | 0 | 5                        | 8    | 8     | 0 | 2                        | 2    | 5     | 0 | 62    |               |
| 8:10 AM                         | 4                       | 6    | 20    | 0 | 1                       | 1    | 1     | 0 | 0                        | 3    | 3     | 0 | 4                        | 1    | 0     | 0 | 44    |               |
| 8:15 AM                         | 0                       | 3    | 6     | 0 | 0                       | 0    | 0     | 0 | 2                        | 0    | 1     | 0 | 3                        | 1    | 1     | 0 | 17    |               |
| 8:20 AM                         | 0                       | 1    | 3     | 0 | 0                       | 0    | 0     | 0 | 0                        | 1    | 0     | 0 | 0                        | 0    | 0     | 0 | 5     |               |
| 8:25 AM                         | 1                       | 1    | 3     | 0 | 0                       | 0    | 1     | 0 | 0                        | 3    | 0     | 0 | 0                        | 1    | 0     | 0 | 10    |               |
| 8:30 AM                         | 0                       | 1    | 3     | 0 | 0                       | 0    | 1     | 0 | 0                        | 0    | 0     | 0 | 0                        | 0    | 0     | 0 | 5     |               |
| 8:35 AM                         | 0                       | 0    | 0     | 0 | 0                       | 0    | 0     | 0 | 0                        | 0    | 1     | 0 | 3                        | 0    | 0     | 0 | 4     |               |
| 8:40 AM                         | 0                       | 0    | 2     | 0 | 0                       | 0    | 0     | 0 | 0                        | 0    | 0     | 0 | 1                        | 0    | 0     | 0 | 3     |               |
| 8:45 AM                         | 0                       | 0    | 1     | 0 | 0                       | 0    | 0     | 0 | 0                        | 0    | 0     | 0 | 1                        | 1    | 0     | 0 | 3     |               |
| 8:50 AM                         | 0                       | 0    | 2     | 0 | 0                       | 0    | 0     | 0 | 0                        | 0    | 0     | 0 | 1                        | 0    | 0     | 0 | 3     |               |
| 8:55 AM                         | 0                       | 0    | 0     | 0 | 1                       | 0    | 0     | 0 | 0                        | 3    | 0     | 0 | 1                        | 1    | 0     | 0 | 6     |               |
| 9:00 AM                         | 0                       | 0    | 0     | 0 | 0                       | 1    | 0     | 0 | 0                        | 1    | 0     | 0 | 0                        | 0    | 0     | 0 | 2     |               |
| 9:05 AM                         | 0                       | 0    | 1     | 0 | 0                       | 0    | 0     | 0 | 0                        | 0    | 0     | 0 | 0                        | 0    | 0     | 0 | 1     |               |



## Attachment B

| 5-Min Count Period Beginning At | Wembley Rd (Northbound) |      |       |   | Wembley Rd (Southbound) |      |       |   | Piedmont Ave (Eastbound) |      |       |   | Piedmont Ave (Westbound) |      |       |   | Total | Hourly Totals |
|---------------------------------|-------------------------|------|-------|---|-------------------------|------|-------|---|--------------------------|------|-------|---|--------------------------|------|-------|---|-------|---------------|
|                                 | Left                    | Thru | Right | U | Left                    | Thru | Right | U | Left                     | Thru | Right | U | Left                     | Thru | Right | U |       |               |
| 4:35 PM                         | 0                       | 0    | 1     | 0 | 0                       | 0    | 0     | 0 | 0                        | 1    | 0     | 0 | 5                        | 1    | 0     | 0 | 8     | 128           |
| 4:40 PM                         | 0                       | 1    | 5     | 0 | 0                       | 0    | 0     | 0 | 0                        | 2    | 1     | 0 | 1                        | 0    | 0     | 0 | 10    | 125           |
| 4:45 PM                         | 0                       | 0    | 3     | 0 | 0                       | 0    | 0     | 0 | 0                        | 0    | 3     | 0 | 3                        | 0    | 0     | 0 | 9     | 122           |
| 4:50 PM                         | 0                       | 0    | 2     | 0 | 0                       | 1    | 0     | 0 | 0                        | 1    | 1     | 0 | 0                        | 1    | 1     | 0 | 7     | 117           |
| 4:55 PM                         | 1                       | 0    | 0     | 0 | 0                       | 0    | 0     | 0 | 0                        | 1    | 3     | 0 | 4                        | 1    | 0     | 0 | 10    | 115           |
| 5:00 PM                         | 0                       | 2    | 2     | 0 | 0                       | 0    | 0     | 0 | 0                        | 1    | 0     | 0 | 3                        | 0    | 1     | 0 | 9     | 109           |
| 5:05 PM                         | 2                       | 0    | 3     | 0 | 0                       | 1    | 0     | 0 | 0                        | 1    | 2     | 0 | 2                        | 1    | 0     | 0 | 12    | 112           |
| 5:10 PM                         | 0                       | 0    | 3     | 0 | 0                       | 0    | 0     | 0 | 0                        | 1    | 1     | 0 | 0                        | 0    | 0     | 0 | 5     | 109           |
| 5:15 PM                         | 1                       | 1    | 4     | 0 | 2                       | 0    | 0     | 0 | 0                        | 1    | 0     | 0 | 3                        | 1    | 0     | 0 | 13    | 111           |
| 5:20 PM                         | 1                       | 0    | 2     | 0 | 1                       | 0    | 0     | 0 | 0                        | 0    | 0     | 0 | 1                        | 0    | 0     | 0 | 5     | 105           |
| 5:25 PM                         | 0                       | 0    | 1     | 0 | 0                       | 0    | 0     | 0 | 0                        | 1    | 1     | 0 | 0                        | 0    | 2     | 0 | 5     | 103           |
| 5:30 PM                         | 0                       | 0    | 1     | 0 | 0                       | 0    | 0     | 0 | 0                        | 1    | 0     | 0 | 0                        | 0    | 0     | 0 | 2     | 95            |
| 5:35 PM                         | 1                       | 0    | 1     | 0 | 0                       | 0    | 0     | 0 | 0                        | 0    | 0     | 0 | 0                        | 1    | 1     | 0 | 4     | 91            |
| 5:40 PM                         | 0                       | 0    | 1     | 0 | 0                       | 0    | 0     | 0 | 0                        | 2    | 0     | 0 | 2                        | 0    | 1     | 0 | 6     | 87            |
| 5:45 PM                         | 0                       | 0    | 3     | 0 | 1                       | 0    | 0     | 0 | 0                        | 1    | 0     | 0 | 1                        | 0    | 0     | 0 | 6     | 84            |
| 5:50 PM                         | 0                       | 0    | 0     | 0 | 0                       | 0    | 0     | 0 | 0                        | 0    | 0     | 0 | 2                        | 0    | 0     | 0 | 2     | 79            |
| 5:55 PM                         | 1                       | 0    | 6     | 0 | 1                       | 0    | 0     | 0 | 0                        | 1    | 0     | 0 | 0                        | 2    | 0     | 0 | 11    | 80            |
| 6:00 PM                         | 1                       | 0    | 6     | 0 | 1                       | 0    | 0     | 0 | 0                        | 0    | 0     | 0 | 0                        | 0    | 0     | 0 | 8     | 79            |
| 6:05 PM                         | 0                       | 0    | 3     | 0 | 1                       | 1    | 0     | 0 | 0                        | 3    | 0     | 0 | 1                        | 1    | 2     | 0 | 12    | 79            |
| 6:10 PM                         | 0                       | 0    | 4     | 0 | 0                       | 0    | 0     | 0 | 0                        | 1    | 0     | 0 | 0                        | 1    | 0     | 0 | 6     | 80            |
| 6:15 PM                         | 0                       | 0    | 3     | 0 | 0                       | 0    | 0     | 0 | 0                        | 2    | 0     | 0 | 0                        | 0    | 0     | 0 | 5     | 72            |
| 6:20 PM                         | 0                       | 0    | 0     | 0 | 0                       | 0    | 0     | 0 | 0                        | 0    | 0     | 0 | 0                        | 1    | 1     | 0 | 2     | 69            |
| 6:25 PM                         | 0                       | 0    | 0     | 0 | 2                       | 1    | 0     | 0 | 0                        | 2    | 0     | 0 | 0                        | 0    | 1     | 0 | 6     | 70            |
| 6:30 PM                         | 0                       | 0    | 0     | 0 | 0                       | 0    | 0     | 0 | 0                        | 1    | 1     | 0 | 0                        | 0    | 0     | 0 | 2     | 70            |
| 6:35 PM                         | 0                       | 0    | 1     | 0 | 1                       | 0    | 0     | 0 | 0                        | 1    | 0     | 0 | 1                        | 3    | 0     | 0 | 7     | 73            |
| 6:40 PM                         | 0                       | 0    | 0     | 0 | 0                       | 0    | 0     | 0 | 0                        | 1    | 0     | 0 | 1                        | 1    | 0     | 0 | 3     | 70            |
| 6:45 PM                         | 0                       | 0    | 1     | 0 | 0                       | 0    | 0     | 0 | 0                        | 1    | 0     | 0 | 0                        | 0    | 0     | 0 | 2     | 66            |
| 6:50 PM                         | 0                       | 0    | 0     | 0 | 0                       | 0    | 0     | 0 | 0                        | 0    | 0     | 0 | 0                        | 1    | 0     | 0 | 1     | 65            |
| 6:55 PM                         | 0                       | 0    | 0     | 0 | 0                       | 0    | 0     | 0 | 0                        | 1    | 0     | 0 | 0                        | 1    | 0     | 0 | 2     | 56            |
| 7:00 PM                         | 0                       | 0    | 0     | 0 | 0                       | 0    | 0     | 0 | 0                        | 0    | 0     | 0 | 0                        | 1    | 0     | 0 | 1     | 49            |
| 7:05 PM                         | 0                       | 0    | 1     | 0 | 0                       | 0    | 0     | 0 | 0                        | 0    | 0     | 0 | 0                        | 1    | 0     | 0 | 2     | 39            |
| 7:10 PM                         | 0                       | 0    | 0     | 0 | 1                       | 0    | 0     | 0 | 0                        | 1    | 0     | 0 | 1                        | 1    | 0     | 0 | 4     | 37            |
| 7:15 PM                         | 0                       | 0    | 0     | 0 | 0                       | 0    | 0     | 0 | 0                        | 0    | 1     | 0 | 0                        | 0    | 0     | 0 | 1     | 33            |
| 7:20 PM                         | 0                       | 0    | 0     | 0 | 0                       | 0    | 0     | 0 | 0                        | 0    | 0     | 0 | 0                        | 1    | 1     | 0 | 2     | 33            |
| 7:25 PM                         | 0                       | 0    | 1     | 0 | 0                       | 0    | 0     | 0 | 0                        | 0    | 0     | 0 | 0                        | 0    | 0     | 0 | 1     | 28            |
| 7:30 PM                         | 0                       | 0    | 0     | 0 | 0                       | 0    | 0     | 0 | 0                        | 0    | 0     | 0 | 0                        | 0    | 0     | 0 | 0     | 26            |
| 7:35 PM                         | 0                       | 0    | 0     | 0 | 0                       | 0    | 0     | 0 | 0                        | 0    | 1     | 0 | 0                        | 0    | 0     | 0 | 1     | 20            |
| 7:40 PM                         | 0                       | 0    | 1     | 0 | 0                       | 0    | 0     | 0 | 0                        | 0    | 0     | 0 | 0                        | 2    | 1     | 0 | 4     | 21            |
| 7:45 PM                         | 0                       | 0    | 0     | 0 | 0                       | 1    | 0     | 0 | 0                        | 0    | 0     | 0 | 0                        | 0    | 0     | 0 | 1     | 20            |
| 7:50 PM                         | 0                       | 1    | 0     | 0 | 0                       | 0    | 0     | 0 | 0                        | 0    | 0     | 0 | 0                        | 0    | 0     | 0 | 1     | 20            |
| 7:55 PM                         | 0                       | 0    | 0     | 0 | 1                       | 0    | 1     | 0 | 0                        | 0    | 0     | 0 | 1                        | 0    | 0     | 0 | 3     | 21            |
| 8:00 PM                         | 0                       | 0    | 0     | 0 | 0                       | 0    | 0     | 0 | 0                        | 0    | 0     | 0 | 0                        | 0    | 0     | 0 | 0     | 20            |
| 8:05 PM                         | 0                       | 0    | 0     | 0 | 0                       | 0    | 0     | 0 | 0                        | 0    | 0     | 0 | 0                        | 1    | 0     | 0 | 1     | 19            |
| 8:10 PM                         | 0                       | 0    | 0     | 0 | 0                       | 0    | 0     | 0 | 0                        | 0    | 0     | 0 | 0                        | 1    | 0     | 0 | 1     | 16            |
| 8:15 PM                         | 0                       | 0    | 0     | 0 | 0                       | 0    | 1     | 0 | 0                        | 0    | 0     | 0 | 0                        | 0    | 0     | 0 | 1     | 16            |
| 8:20 PM                         | 0                       | 0    | 0     | 0 | 0                       | 0    | 0     | 0 | 0                        | 0    | 0     | 0 | 0                        | 0    | 0     | 0 | 0     | 14            |
| 8:25 PM                         | 0                       | 0    | 0     | 0 | 0                       | 0    | 0     | 0 | 0                        | 0    | 0     | 0 | 0                        | 0    | 0     | 0 | 0     | 13            |
| 8:30 PM                         | 0                       | 0    | 0     | 0 | 0                       | 0    | 0     | 0 | 0                        | 0    | 0     | 0 | 0                        | 0    | 1     | 0 | 1     | 14            |
| 8:35 PM                         | 0                       | 0    | 0     | 0 | 0                       | 0    | 0     | 0 | 0                        | 0    | 0     | 0 | 0                        | 0    | 0     | 0 | 0     | 13            |
| 8:40 PM                         | 0                       | 0    | 0     | 0 | 0                       | 0    | 0     | 0 | 0                        | 0    | 0     | 0 | 0                        | 0    | 0     | 0 | 0     | 9             |
| 8:45 PM                         | 0                       | 0    | 0     | 0 | 0                       | 0    | 0     | 0 | 0                        | 0    | 0     | 0 | 0                        | 1    | 0     | 0 | 1     | 9             |
| 8:50 PM                         | 0                       | 0    | 0     | 0 | 0                       | 0    | 0     | 0 | 0                        | 1    | 0     | 0 | 0                        | 0    | 0     | 0 | 1     | 9             |
| 8:55 PM                         | 0                       | 0    | 0     | 0 | 0                       | 0    | 0     | 0 | 0                        | 0    | 0     | 0 | 0                        | 0    | 0     | 0 | 0     | 6             |
| 9:00 PM                         | 0                       | 1    | 0     | 0 | 0                       | 0    | 0     | 0 | 0                        | 1    | 0     | 0 | 0                        | 0    | 0     | 0 | 2     | 8             |
| 9:05 PM                         | 1                       | 0    | 0     | 0 | 0                       | 1    | 0     | 0 | 0                        | 0    | 0     | 0 | 0                        | 0    | 0     | 0 | 2     | 9             |
| 9:10 PM                         | 0                       | 0    | 0     | 0 | 0                       | 0    | 0     | 0 | 0                        | 0    | 0     | 0 | 0                        | 1    | 0     | 0 | 1     | 9             |
| 9:15 PM                         | 0                       | 0    | 0     | 0 | 0                       | 0    | 0     | 0 | 0                        | 1    | 0     | 0 | 0                        | 0    | 0     | 0 | 1     | 9             |
| 9:20 PM                         | 0                       | 0    | 0     | 0 | 0                       | 0    | 0     | 0 | 0                        | 0    | 0     | 0 | 0                        | 0    | 0     | 0 | 0     | 9             |
| 9:25 PM                         | 0                       | 0    | 0     | 0 | 0                       | 0    | 0     | 0 | 0                        | 0    | 0     | 0 | 0                        | 0    | 0     | 0 | 0     | 9             |
| 9:30 PM                         | 0                       | 0    | 0     | 0 | 0                       | 0    | 0     | 0 | 0                        | 0    | 0     | 0 | 0                        | 0    | 0     | 0 | 0     | 8             |
| 9:35 PM                         | 0                       | 0    | 0     | 0 | 0                       | 0    | 0     | 0 | 0                        | 0    | 0     | 0 | 0                        | 0    | 0     | 0 | 0     | 8             |
| 9:40 PM                         | 0                       | 0    | 0     | 0 | 0                       | 0    | 0     | 0 | 0                        | 0    | 0     | 0 | 0                        | 0    | 0     | 0 | 0     | 8             |
| 9:45 PM                         | 0                       | 0    | 0     | 0 | 1                       | 1    | 0     | 0 | 0                        | 0    | 0     | 0 | 0                        | 0    | 0     | 0 | 2     | 9             |
| 9:50 PM                         | 0                       | 0    | 0     | 0 | 0                       | 0    | 0     | 0 | 0                        | 1    | 0     | 0 | 0                        | 0    | 0     | 0 | 1     | 9             |
| 9:55 PM                         | 0                       | 0    | 1     | 0 | 0                       | 0    | 0     | 0 | 0                        | 1    | 0     | 0 | 0                        | 0    | 0     | 0 | 2     | 11            |
| Peak 15-Min Flowrates           | Northbound              |      |       |   | Southbound              |      |       |   | Eastbound                |      |       |   | Westbound                |      |       |   | Total |               |
|                                 | Left                    | Thru | Right | U | Left                    | Thru | Right | U | Left                     | Thru | Right | U | Left                     | Thru | Right | U |       |               |
| All Vehicles                    | 72                      | 96   | 148   | 0 | 8                       | 16   | 8     | 0 | 36                       | 88   | 64    | 0 | 36                       | 12   | 28    | 0 | 612   |               |
| Heavy Trucks                    | 0                       | 8    | 0     |   | 0                       | 0    | 0     |   | 0                        | 0    | 0     |   | 0                        | 0    | 0     |   | 8     |               |
| Buses                           |                         | 92   |       |   |                         | 76   |       |   |                          | 0    |       |   |                          | 156  |       |   | 324   |               |
| Pedestrians                     |                         |      |       |   |                         |      |       |   |                          |      |       |   |                          |      |       |   | 4     |               |
| Bicycles                        | 4                       | 0    | 0     |   | 0                       | 0    | 0     |   | 0                        | 0    | 0     |   | 0                        | 0    | 0     |   |       |               |
| Scoters                         |                         |      |       |   |                         |      |       |   |                          |      |       |   |                          |      |       |   |       |               |

Comments:

Type of peak hour being reported: Intersection Peak

Method for determining peak hour: Total Entering Volume

LOCATION: Wembley Rd -- Shakespeare Dr  
 CITY/STATE: Rossmore, CA

QC JOB #: 16966412  
 DATE: Wed, Apr 9 2025

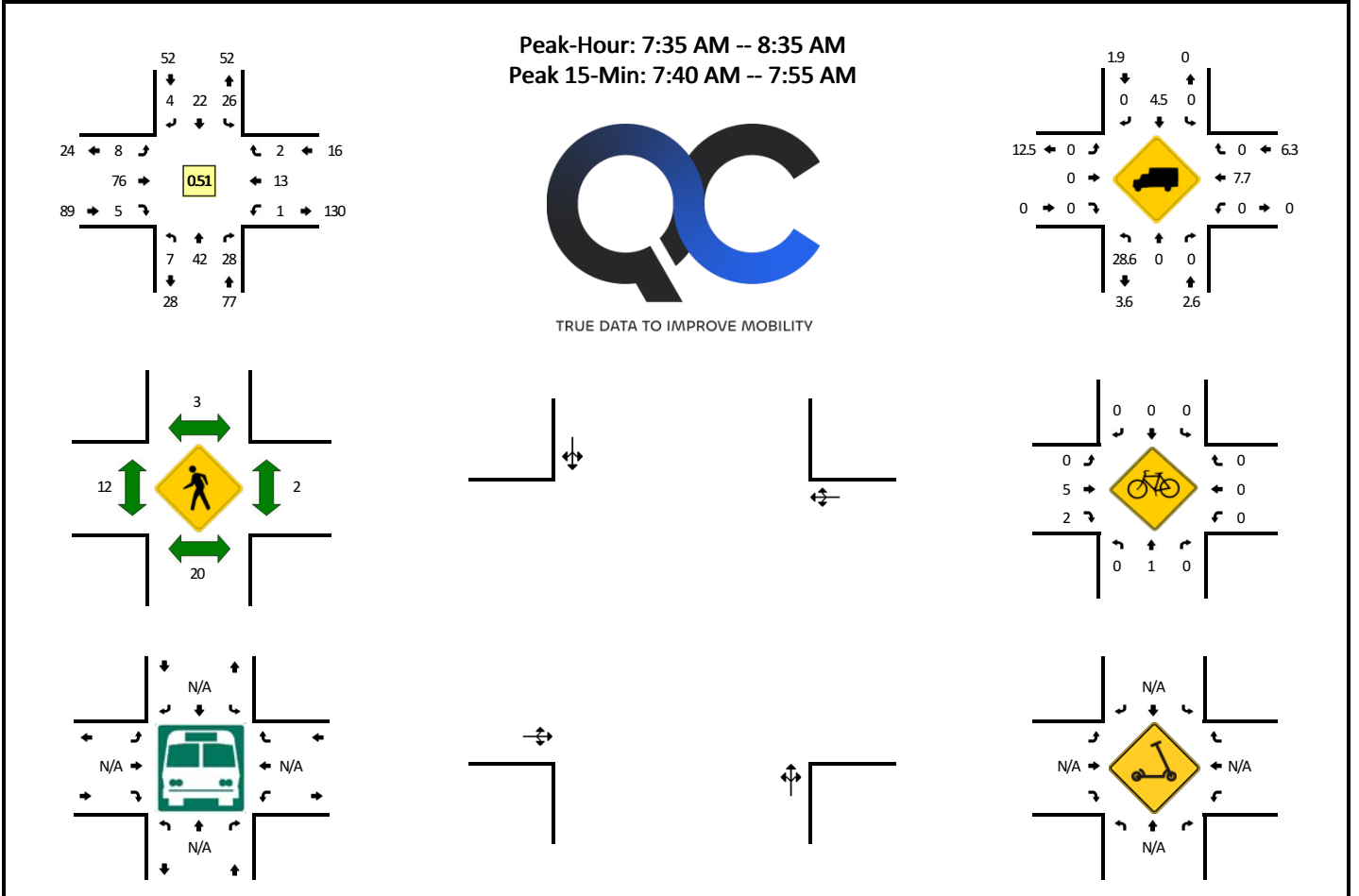

| 5-Min Count Period Beginning At | Wembley Rd (Northbound) |      |       |   | Wembley Rd (Southbound) |      |       |   | Shakespeare Dr (Eastbound) |      |       |   | Shakespeare Dr (Westbound) |      |       |   | Total | Hourly Totals |     |
|---------------------------------|-------------------------|------|-------|---|-------------------------|------|-------|---|----------------------------|------|-------|---|----------------------------|------|-------|---|-------|---------------|-----|
|                                 | Left                    | Thru | Right | U | Left                    | Thru | Right | U | Left                       | Thru | Right | U | Left                       | Thru | Right | U |       |               |     |
| 6:00 AM                         | 0                       | 0    | 0     | 0 | 0                       | 0    | 0     | 0 | 0                          | 2    | 0     | 0 | 0                          | 0    | 0     | 0 | 2     |               |     |
| 6:05 AM                         | 0                       | 0    | 0     | 0 | 0                       | 0    | 0     | 0 | 0                          | 0    | 1     | 0 | 0                          | 0    | 0     | 1 | 0     | 2             |     |
| 6:10 AM                         | 0                       | 0    | 0     | 0 | 0                       | 0    | 0     | 0 | 0                          | 0    | 0     | 0 | 0                          | 0    | 0     | 0 | 0     | 0             |     |
| 6:15 AM                         | 0                       | 0    | 0     | 0 | 0                       | 0    | 1     | 0 | 0                          | 0    | 1     | 0 | 0                          | 0    | 0     | 0 | 0     | 2             |     |
| 6:20 AM                         | 0                       | 0    | 0     | 0 | 0                       | 0    | 0     | 0 | 0                          | 0    | 0     | 0 | 0                          | 0    | 0     | 0 | 0     | 0             |     |
| 6:25 AM                         | 0                       | 0    | 0     | 0 | 0                       | 0    | 0     | 0 | 0                          | 0    | 1     | 0 | 0                          | 0    | 0     | 0 | 0     | 1             |     |
| 6:30 AM                         | 0                       | 0    | 0     | 0 | 0                       | 0    | 0     | 0 | 0                          | 0    | 1     | 0 | 0                          | 0    | 0     | 0 | 0     | 1             |     |
| 6:35 AM                         | 0                       | 0    | 0     | 0 | 0                       | 0    | 0     | 0 | 0                          | 0    | 0     | 0 | 0                          | 0    | 0     | 0 | 0     | 0             |     |
| 6:40 AM                         | 0                       | 0    | 0     | 0 | 0                       | 0    | 0     | 0 | 0                          | 0    | 0     | 0 | 0                          | 0    | 0     | 0 | 0     | 0             |     |
| 6:45 AM                         | 0                       | 0    | 0     | 0 | 0                       | 0    | 0     | 0 | 0                          | 1    | 0     | 0 | 0                          | 0    | 1     | 0 | 0     | 2             |     |
| 6:50 AM                         | 0                       | 0    | 1     | 0 | 1                       | 0    | 0     | 0 | 0                          | 1    | 3     | 0 | 0                          | 0    | 2     | 0 | 0     | 8             |     |
| 6:55 AM                         | 0                       | 0    | 0     | 0 | 1                       | 0    | 0     | 0 | 0                          | 0    | 3     | 0 | 0                          | 0    | 1     | 0 | 0     | 5             | 23  |
| 7:00 AM                         | 0                       | 0    | 0     | 0 | 0                       | 0    | 0     | 0 | 0                          | 0    | 0     | 1 | 0                          | 0    | 0     | 0 | 0     | 1             | 22  |
| 7:05 AM                         | 0                       | 0    | 0     | 0 | 0                       | 0    | 0     | 0 | 0                          | 0    | 0     | 0 | 0                          | 0    | 1     | 0 | 0     | 1             | 21  |
| 7:10 AM                         | 0                       | 0    | 1     | 0 | 0                       | 0    | 0     | 0 | 0                          | 0    | 5     | 0 | 0                          | 0    | 1     | 0 | 0     | 7             | 28  |
| 7:15 AM                         | 0                       | 1    | 1     | 0 | 0                       | 1    | 0     | 0 | 0                          | 0    | 0     | 0 | 0                          | 0    | 0     | 0 | 0     | 3             | 29  |
| 7:20 AM                         | 0                       | 0    | 0     | 0 | 2                       | 0    | 0     | 0 | 0                          | 0    | 0     | 0 | 0                          | 0    | 0     | 0 | 0     | 2             | 31  |
| 7:25 AM                         | 0                       | 0    | 0     | 0 | 0                       | 0    | 0     | 0 | 0                          | 0    | 3     | 0 | 0                          | 0    | 0     | 0 | 0     | 3             | 33  |
| 7:30 AM                         | 0                       | 0    | 0     | 0 | 1                       | 0    | 0     | 0 | 0                          | 0    | 2     | 0 | 0                          | 0    | 0     | 0 | 0     | 3             | 35  |
| 7:35 AM                         | 1                       | 0    | 2     | 0 | 1                       | 1    | 0     | 0 | 0                          | 0    | 3     | 0 | 0                          | 0    | 1     | 0 | 0     | 9             | 44  |
| 7:40 AM                         | 2                       | 6    | 3     | 0 | 5                       | 5    | 0     | 0 | 0                          | 0    | 9     | 1 | 0                          | 0    | 0     | 0 | 0     | 31            | 75  |
| 7:45 AM                         | 1                       | 7    | 5     | 0 | 7                       | 7    | 0     | 0 | 0                          | 1    | 11    | 1 | 0                          | 0    | 0     | 0 | 0     | 40            | 113 |
| 7:50 AM                         | 2                       | 11   | 3     | 0 | 5                       | 5    | 2     | 0 | 0                          | 2    | 11    | 1 | 0                          | 1    | 0     | 0 | 0     | 43            | 148 |
| 7:55 AM                         | 1                       | 6    | 2     | 0 | 5                       | 1    | 1     | 0 | 0                          | 0    | 14    | 0 | 0                          | 0    | 1     | 0 | 0     | 31            | 174 |
| 8:00 AM                         | 0                       | 4    | 2     | 0 | 1                       | 1    | 1     | 0 | 0                          | 3    | 7     | 2 | 0                          | 0    | 1     | 1 | 0     | 23            | 196 |
| 8:05 AM                         | 0                       | 4    | 3     | 0 | 1                       | 0    | 0     | 0 | 0                          | 1    | 2     | 0 | 0                          | 0    | 4     | 1 | 0     | 16            | 211 |
| 8:10 AM                         | 0                       | 1    | 2     | 0 | 0                       | 1    | 0     | 0 | 0                          | 1    | 6     | 0 | 0                          | 0    | 1     | 0 | 0     | 12            | 216 |
| 8:15 AM                         | 0                       | 1    | 3     | 0 | 0                       | 0    | 0     | 0 | 0                          | 0    | 3     | 0 | 0                          | 0    | 0     | 0 | 0     | 7             | 220 |
| 8:20 AM                         | 0                       | 0    | 0     | 0 | 1                       | 0    | 0     | 0 | 0                          | 0    | 3     | 0 | 0                          | 0    | 1     | 0 | 0     | 5             | 223 |
| 8:25 AM                         | 0                       | 0    | 1     | 0 | 0                       | 1    | 0     | 0 | 0                          | 0    | 4     | 0 | 0                          | 0    | 2     | 0 | 0     | 8             | 228 |
| 8:30 AM                         | 0                       | 2    | 2     | 0 | 0                       | 0    | 0     | 0 | 0                          | 0    | 3     | 0 | 0                          | 0    | 2     | 0 | 0     | 9             | 234 |
| 8:35 AM                         | 0                       | 0    | 0     | 0 | 0                       | 0    | 0     | 0 | 0                          | 0    | 3     | 0 | 0                          | 0    | 0     | 0 | 0     | 3             | 228 |
| 8:40 AM                         | 0                       | 0    | 2     | 0 | 0                       | 0    | 0     | 0 | 0                          | 0    | 1     | 0 | 0                          | 0    | 1     | 2 | 0     | 6             | 203 |
| 8:45 AM                         | 0                       | 0    | 1     | 0 | 0                       | 0    | 0     | 0 | 0                          | 0    | 1     | 0 | 0                          | 0    | 1     | 0 | 0     | 3             | 166 |
| 8:50 AM                         | 0                       | 1    | 0     | 0 | 0                       | 0    | 0     | 0 | 0                          | 1    | 0     | 0 | 0                          | 1    | 0     | 0 | 0     | 3             | 126 |
| 8:55 AM                         | 0                       | 1    | 0     | 0 | 0                       | 0    | 0     | 0 | 0                          | 0    | 1     | 1 | 0                          | 0    | 1     | 1 | 0     | 5             | 100 |
| 9:00 AM                         | 0                       | 0    | 1     | 0 | 0                       | 0    | 0     | 0 | 0                          | 0    | 0     | 0 | 0                          | 0    | 0     | 0 | 0     | 1             | 78  |
| 9:05 AM                         | 0                       | 0    | 2     | 0 | 0                       | 1    | 0     | 0 | 0                          | 0    | 2     | 0 | 0                          | 0    | 0     | 0 | 0     | 5             | 67  |

Attachment B

| 5-Min Count Period Beginning At | Wembley Rd (Northbound) |      |       |   | Wembley Rd (Southbound) |      |       |   | Shakespeare Dr (Eastbound) |      |       |   | Shakespeare Dr (Westbound) |      |       |   | Total | Hourly Totals |
|---------------------------------|-------------------------|------|-------|---|-------------------------|------|-------|---|----------------------------|------|-------|---|----------------------------|------|-------|---|-------|---------------|
|                                 | Left                    | Thru | Right | U | Left                    | Thru | Right | U | Left                       | Thru | Right | U | Left                       | Thru | Right | U |       |               |
| 9:10 AM                         | 0                       | 0    | 1     | 0 | 0                       | 0    | 0     | 0 | 0                          | 1    | 0     | 0 | 0                          | 0    | 0     | 0 | 2     | 57            |
| 9:15 AM                         | 0                       | 0    | 2     | 0 | 0                       | 0    | 0     | 0 | 0                          | 0    | 0     | 0 | 0                          | 0    | 0     | 0 | 2     | 52            |
| 9:20 AM                         | 0                       | 0    | 1     | 0 | 0                       | 0    | 0     | 0 | 0                          | 0    | 3     | 0 | 0                          | 0    | 1     | 0 | 5     | 52            |
| 9:25 AM                         | 0                       | 0    | 0     | 0 | 0                       | 0    | 0     | 0 | 1                          | 1    | 1     | 0 | 0                          | 1    | 0     | 0 | 4     | 48            |
| 9:30 AM                         | 0                       | 1    | 0     | 0 | 1                       | 0    | 0     | 0 | 0                          | 0    | 0     | 0 | 0                          | 2    | 0     | 0 | 4     | 43            |
| 9:35 AM                         | 0                       | 0    | 1     | 0 | 0                       | 0    | 0     | 0 | 0                          | 2    | 0     | 0 | 0                          | 0    | 3     | 0 | 6     | 46            |
| 9:40 AM                         | 0                       | 0    | 1     | 0 | 0                       | 0    | 0     | 0 | 0                          | 3    | 0     | 0 | 0                          | 2    | 0     | 0 | 6     | 46            |
| 9:45 AM                         | 0                       | 0    | 0     | 0 | 0                       | 0    | 1     | 0 | 0                          | 0    | 0     | 0 | 2                          | 1    | 0     | 0 | 4     | 47            |
| 9:50 AM                         | 0                       | 0    | 0     | 0 | 0                       | 0    | 0     | 0 | 0                          | 0    | 0     | 0 | 0                          | 1    | 0     | 0 | 1     | 45            |
| 9:55 AM                         | 0                       | 1    | 0     | 0 | 1                       | 0    | 0     | 0 | 0                          | 1    | 0     | 0 | 0                          | 0    | 0     | 0 | 3     | 43            |
| 10:00 AM                        | 0                       | 0    | 0     | 0 | 0                       | 0    | 0     | 0 | 0                          | 3    | 1     | 0 | 0                          | 1    | 1     | 0 | 6     | 48            |
| 10:05 AM                        | 0                       | 0    | 0     | 0 | 0                       | 0    | 0     | 0 | 0                          | 1    | 0     | 0 | 0                          | 1    | 0     | 0 | 2     | 45            |
| 10:10 AM                        | 0                       | 0    | 1     | 0 | 0                       | 0    | 0     | 0 | 0                          | 0    | 0     | 0 | 0                          | 1    | 0     | 0 | 2     | 45            |
| 10:15 AM                        | 0                       | 0    | 0     | 0 | 0                       | 0    | 0     | 0 | 0                          | 0    | 0     | 0 | 0                          | 1    | 0     | 0 | 1     | 44            |
| 10:20 AM                        | 0                       | 0    | 0     | 0 | 0                       | 0    | 0     | 0 | 0                          | 2    | 0     | 0 | 0                          | 1    | 0     | 0 | 3     | 42            |
| 10:25 AM                        | 0                       | 0    | 1     | 0 | 0                       | 0    | 0     | 0 | 0                          | 0    | 0     | 0 | 1                          | 1    | 0     | 0 | 3     | 41            |
| 10:30 AM                        | 0                       | 0    | 0     | 0 | 0                       | 0    | 0     | 0 | 0                          | 0    | 0     | 0 | 0                          | 0    | 0     | 0 | 0     | 37            |
| 10:35 AM                        | 0                       | 0    | 0     | 0 | 0                       | 0    | 0     | 0 | 0                          | 4    | 0     | 0 | 1                          | 2    | 0     | 0 | 7     | 38            |
| 10:40 AM                        | 0                       | 0    | 0     | 0 | 0                       | 0    | 1     | 0 | 0                          | 0    | 0     | 0 | 0                          | 1    | 0     | 0 | 2     | 34            |
| 10:45 AM                        | 0                       | 0    | 1     | 0 | 0                       | 0    | 1     | 0 | 0                          | 2    | 1     | 0 | 1                          | 1    | 0     | 0 | 7     | 37            |
| 10:50 AM                        | 0                       | 0    | 0     | 0 | 0                       | 0    | 0     | 0 | 0                          | 1    | 0     | 0 | 0                          | 1    | 0     | 0 | 2     | 38            |
| 10:55 AM                        | 0                       | 1    | 0     | 0 | 0                       | 0    | 0     | 0 | 0                          | 1    | 0     | 0 | 0                          | 2    | 0     | 0 | 4     | 39            |
| 11:00 AM                        | 0                       | 0    | 2     | 0 | 0                       | 0    | 0     | 0 | 0                          | 0    | 0     | 0 | 0                          | 0    | 0     | 0 | 2     | 35            |
| 11:05 AM                        | 0                       | 1    | 0     | 0 | 0                       | 0    | 0     | 0 | 0                          | 2    | 1     | 0 | 0                          | 1    | 0     | 0 | 5     | 38            |
| 11:10 AM                        | 0                       | 0    | 1     | 0 | 0                       | 0    | 0     | 0 | 0                          | 0    | 0     | 0 | 2                          | 0    | 0     | 0 | 3     | 39            |
| 11:15 AM                        | 0                       | 0    | 0     | 0 | 0                       | 0    | 1     | 0 | 0                          | 2    | 0     | 0 | 1                          | 2    | 0     | 0 | 6     | 44            |
| 11:20 AM                        | 0                       | 0    | 0     | 0 | 0                       | 0    | 0     | 0 | 0                          | 1    | 0     | 0 | 0                          | 0    | 0     | 0 | 1     | 42            |
| 11:25 AM                        | 0                       | 0    | 0     | 0 | 0                       | 0    | 0     | 0 | 0                          | 0    | 0     | 0 | 2                          | 0    | 0     | 0 | 2     | 41            |
| 11:30 AM                        | 0                       | 2    | 0     | 0 | 0                       | 0    | 0     | 0 | 0                          | 0    | 0     | 0 | 0                          | 2    | 0     | 0 | 4     | 45            |
| 11:35 AM                        | 0                       | 0    | 1     | 0 | 1                       | 1    | 0     | 0 | 0                          | 2    | 0     | 0 | 0                          | 0    | 0     | 0 | 5     | 43            |
| 11:40 AM                        | 0                       | 1    | 0     | 0 | 1                       | 0    | 0     | 0 | 1                          | 0    | 0     | 0 | 1                          | 1    | 0     | 0 | 5     | 46            |
| 11:45 AM                        | 0                       | 0    | 0     | 0 | 0                       | 0    | 0     | 0 | 1                          | 1    | 0     | 0 | 0                          | 1    | 0     | 0 | 3     | 42            |
| 11:50 AM                        | 0                       | 0    | 1     | 0 | 0                       | 0    | 1     | 0 | 1                          | 1    | 0     | 0 | 0                          | 1    | 0     | 0 | 5     | 45            |
| 11:55 AM                        | 0                       | 0    | 0     | 0 | 0                       | 0    | 0     | 0 | 0                          | 2    | 0     | 0 | 0                          | 2    | 0     | 0 | 4     | 45            |
| 12:00 PM                        | 0                       | 0    | 1     | 0 | 0                       | 0    | 0     | 0 | 0                          | 1    | 0     | 0 | 2                          | 1    | 0     | 0 | 5     | 48            |
| 12:05 PM                        | 0                       | 0    | 1     | 0 | 0                       | 1    | 0     | 0 | 0                          | 1    | 0     | 0 | 0                          | 0    | 1     | 0 | 4     | 47            |
| 12:10 PM                        | 0                       | 0    | 0     | 0 | 0                       | 0    | 0     | 0 | 0                          | 1    | 0     | 0 | 0                          | 1    | 0     | 0 | 2     | 46            |
| 12:15 PM                        | 0                       | 1    | 0     | 0 | 0                       | 0    | 0     | 0 | 0                          | 0    | 0     | 0 | 0                          | 1    | 0     | 0 | 2     | 42            |
| 12:20 PM                        | 0                       | 0    | 0     | 0 | 0                       | 0    | 0     | 0 | 0                          | 2    | 0     | 0 | 1                          | 2    | 0     | 0 | 5     | 46            |
| 12:25 PM                        | 0                       | 0    | 0     | 0 | 0                       | 0    | 0     | 0 | 0                          | 0    | 0     | 0 | 0                          | 0    | 1     | 0 | 1     | 45            |
| 12:30 PM                        | 0                       | 0    | 0     | 0 | 0                       | 0    | 0     | 0 | 0                          | 1    | 0     | 0 | 1                          | 2    | 0     | 0 | 4     | 45            |
| 12:35 PM                        | 0                       | 0    | 0     | 0 | 1                       | 0    | 0     | 0 | 0                          | 0    | 0     | 0 | 0                          | 1    | 0     | 0 | 2     | 42            |
| 12:40 PM                        | 0                       | 0    | 0     | 0 | 0                       | 0    | 0     | 0 | 0                          | 0    | 0     | 0 | 0                          | 1    | 1     | 0 | 2     | 39            |
| 12:45 PM                        | 0                       | 0    | 0     | 0 | 0                       | 0    | 0     | 0 | 0                          | 3    | 0     | 0 | 0                          | 1    | 1     | 0 | 5     | 41            |
| 12:50 PM                        | 0                       | 0    | 0     | 0 | 0                       | 2    | 1     | 0 | 0                          | 0    | 0     | 0 | 0                          | 2    | 0     | 0 | 5     | 41            |
| 12:55 PM                        | 0                       | 0    | 1     | 0 | 0                       | 0    | 0     | 0 | 0                          | 0    | 0     | 0 | 0                          | 2    | 0     | 0 | 3     | 40            |
| 1:00 PM                         | 0                       | 0    | 0     | 0 | 0                       | 0    | 0     | 0 | 0                          | 0    | 0     | 0 | 2                          | 2    | 0     | 0 | 4     | 39            |
| 1:05 PM                         | 0                       | 0    | 1     | 0 | 0                       | 0    | 0     | 0 | 0                          | 1    | 0     | 0 | 0                          | 0    | 0     | 0 | 2     | 37            |
| 1:10 PM                         | 0                       | 0    | 0     | 0 | 0                       | 0    | 0     | 0 | 0                          | 1    | 0     | 0 | 0                          | 2    | 0     | 0 | 3     | 38            |
| 1:15 PM                         | 0                       | 0    | 2     | 0 | 3                       | 1    | 0     | 0 | 0                          | 1    | 0     | 0 | 0                          | 3    | 2     | 0 | 12    | 48            |
| 1:20 PM                         | 0                       | 0    | 4     | 0 | 1                       | 2    | 0     | 0 | 0                          | 3    | 0     | 0 | 1                          | 1    | 1     | 0 | 13    | 56            |
| 1:25 PM                         | 0                       | 0    | 0     | 0 | 3                       | 4    | 2     | 0 | 1                          | 4    | 0     | 0 | 1                          | 1    | 0     | 0 | 16    | 71            |
| 1:30 PM                         | 0                       | 6    | 3     | 0 | 0                       | 5    | 0     | 0 | 0                          | 2    | 0     | 0 | 1                          | 2    | 2     | 0 | 21    | 88            |
| 1:35 PM                         | 3                       | 12   | 6     | 0 | 1                       | 1    | 0     | 0 | 0                          | 4    | 1     | 0 | 2                          | 4    | 0     | 0 | 34    | 120           |
| 1:40 PM                         | 0                       | 6    | 3     | 0 | 0                       | 0    | 0     | 0 | 0                          | 1    | 0     | 0 | 1                          | 0    | 2     | 0 | 13    | 131           |
| 1:45 PM                         | 1                       | 0    | 1     | 0 | 1                       | 0    | 0     | 0 | 0                          | 1    | 0     | 0 | 1                          | 2    | 0     | 0 | 7     | 133           |
| 1:50 PM                         | 0                       | 2    | 1     | 0 | 0                       | 0    | 0     | 0 | 0                          | 1    | 0     | 0 | 0                          | 2    | 1     | 0 | 7     | 135           |
| 1:55 PM                         | 0                       | 1    | 0     | 0 | 0                       | 0    | 0     | 0 | 0                          | 2    | 0     | 0 | 0                          | 3    | 0     | 0 | 6     | 138           |
| 2:00 PM                         | 0                       | 1    | 1     | 0 | 0                       | 0    | 0     | 0 | 0                          | 0    | 0     | 0 | 1                          | 3    | 0     | 0 | 6     | 140           |
| 2:05 PM                         | 0                       | 0    | 0     | 0 | 0                       | 0    | 0     | 0 | 0                          | 2    | 1     | 0 | 0                          | 3    | 0     | 0 | 6     | 144           |
| 2:10 PM                         | 0                       | 1    | 1     | 0 | 1                       | 0    | 0     | 0 | 0                          | 1    | 0     | 0 | 1                          | 4    | 0     | 0 | 9     | 150           |
| 2:15 PM                         | 0                       | 2    | 1     | 0 | 1                       | 0    | 0     | 0 | 0                          | 1    | 0     | 0 | 0                          | 2    | 1     | 0 | 8     | 146           |
| 2:20 PM                         | 0                       | 1    | 0     | 0 | 0                       | 0    | 0     | 0 | 0                          | 2    | 1     | 0 | 0                          | 2    | 0     | 0 | 6     | 139           |
| 2:25 PM                         | 0                       | 1    | 1     | 0 | 0                       | 0    | 0     | 0 | 0                          | 0    | 1     | 0 | 2                          | 1    | 0     | 0 | 6     | 129           |
| 2:30 PM                         | 0                       | 0    | 0     | 0 | 3                       | 0    | 0     | 0 | 0                          | 1    | 0     | 0 | 0                          | 4    | 1     | 0 | 9     | 117           |
| 2:35 PM                         | 0                       | 3    | 0     | 0 | 1                       | 0    | 0     | 0 | 0                          | 1    | 0     | 0 | 0                          | 4    | 0     | 0 | 9     | 92            |
| 2:40 PM                         | 0                       | 1    | 0     | 0 | 0                       | 0    | 2     | 0 | 0                          | 2    | 0     | 0 | 0                          | 1    | 1     | 0 | 7     | 86            |
| 2:45 PM                         | 0                       | 1    | 1     | 0 | 1                       | 1    | 0     | 0 | 0                          | 1    | 0     | 0 | 0                          | 4    | 0     | 0 | 9     | 88            |
| 2:50 PM                         | 1                       | 0    | 0     | 0 | 0                       | 0    | 0     | 0 | 0                          | 2    | 0     | 0 | 0                          | 2    | 1     | 0 | 6     | 87            |
| 2:55 PM                         | 0                       | 2    | 0     | 0 | 3                       | 1    | 0     | 0 | 0                          | 1    | 0     | 0 | 0                          | 5    | 0     | 0 | 12    | 93            |
| 3:00 PM                         | 0                       | 1    | 1     | 0 | 0                       | 0    | 0     | 0 | 0                          | 1    | 0     | 0 | 0                          | 0    | 0     | 0 | 3     | 90            |
| 3:05 PM                         | 0                       | 1    | 0     | 0 | 0                       | 0    | 0     | 0 | 0                          | 1    | 0     | 0 | 0                          | 3    | 1     | 0 | 6     | 90            |
| 3:10 PM                         | 0                       | 0    | 0     | 0 | 0                       | 0    | 0     | 0 | 0                          | 1    | 0     | 0 | 0                          | 1    | 0     | 0 | 2     | 83            |
| 3:15 PM                         | 0                       | 0    | 0     | 0 | 0                       | 1    | 0     | 0 | 0                          | 1    | 0     | 0 | 0                          | 3    | 1     | 0 | 6     | 81            |
| 3:20 PM                         | 0                       | 0    | 0     | 0 | 0                       | 0    | 0     | 0 | 0                          | 2    | 0     | 0 | 1                          | 0    | 0     | 0 | 3     | 78            |
| 3:25 PM                         | 0                       | 0    | 2     | 0 | 0                       | 0    | 0     | 0 | 0                          | 2    | 0     | 0 | 0                          | 2    | 1     | 0 | 7     | 79            |
| 3:30 PM                         | 1                       | 0    | 0     | 0 | 0                       | 0    | 0     | 0 | 0                          | 0    | 0     | 0 | 0                          | 3    | 1     | 0 | 5     | 75            |
| 3:35 PM                         | 0                       | 0    | 1     | 0 | 1                       | 0    | 0     | 0 | 0                          | 0    | 0     | 0 | 0                          | 2    | 0     | 0 | 4     | 70            |
| 3:40 PM                         | 0                       | 0    | 1     | 0 | 1                       | 0    | 0     | 0 | 0                          | 0    | 0     | 0 | 0                          | 1    | 0     | 0 | 3     | 66            |
| 3:45 PM                         | 0                       | 1    | 1     | 0 | 0                       | 0    | 0     | 0 | 0                          | 0    | 0     | 0 | 0                          | 4    | 1     | 0 | 7     | 64            |
| 3:50 PM                         | 0                       | 0    | 1     | 0 | 1                       | 0    | 0     | 0 | 0                          | 4    | 0     | 0 | 3                          | 2    | 2     | 0 | 13    | 71            |
| 3:55 PM                         | 0                       | 1    | 1     | 0 | 0                       | 0    | 0     | 0 | 0                          | 2    | 0     | 0 | 0                          | 1    | 0     | 0 | 5     | 64            |
| 4:00 PM                         | 0                       | 0    | 2     | 0 | 1                       | 1    | 0     | 0 | 0                          | 4    | 0     | 0 | 1                          | 0    | 1     | 0 | 10    | 71            |
| 4:05 PM                         | 0                       | 0    | 0     | 0 | 1                       | 0    | 0     | 0 | 0                          | 1    | 0     | 0 | 0                          | 0    | 0     | 0 | 2     | 67            |
| 4:10 PM                         | 0                       | 3    | 0     | 0 | 1                       | 0    | 0     | 0 | 0                          | 2    | 0     | 0 | 0                          | 2    | 0     | 0 | 8     | 73            |
| 4:15 PM                         | 0                       | 0    | 0     | 0 | 0                       | 0    | 0     | 0 | 0                          | 0    | 0     | 0 | 0                          | 2    | 0     | 0 | 2     | 69            |
| 4:20 PM                         | 0                       | 0    | 0     | 0 | 0                       | 0    | 1     | 0 | 2                          | 0    | 0     | 0 | 0                          | 2    | 0     | 0 | 5     | 71            |
| 4:25 PM                         | 0                       | 1    | 3     | 0 | 1                       | 0    | 0     | 0 | 1                          | 3    | 0     | 0 | 1                          | 6    | 0     | 0 | 16    | 80            |
| 4:30 PM                         | 0                       | 2    | 0     | 0 | 2                       | 1    | 0     | 0 | 0                          | 1    | 0     | 0 | 1                          | 1    | 1     | 0 | 9     | 84            |

## Attachment B

| 5-Min Count Period Beginning At | Wembley Rd (Northbound) |      |       |   | Wembley Rd (Southbound) |      |       |   | Shakespeare Dr (Eastbound) |      |       |   | Shakespeare Dr (Westbound) |      |       |   | Total | Hourly Totals |    |    |
|---------------------------------|-------------------------|------|-------|---|-------------------------|------|-------|---|----------------------------|------|-------|---|----------------------------|------|-------|---|-------|---------------|----|----|
|                                 | Left                    | Thru | Right | U | Left                    | Thru | Right | U | Left                       | Thru | Right | U | Left                       | Thru | Right | U |       |               |    |    |
| 4:35 PM                         | 0                       | 0    | 1     | 0 | 1                       | 0    | 0     | 0 | 0                          | 0    | 0     | 0 | 0                          | 1    | 2     | 0 | 0     | 5             | 85 |    |
| 4:40 PM                         | 0                       | 0    | 0     | 0 | 1                       | 1    | 0     | 0 | 0                          | 0    | 1     | 0 | 0                          | 0    | 2     | 1 | 0     | 0             | 6  | 88 |
| 4:45 PM                         | 0                       | 2    | 1     | 0 | 1                       | 0    | 0     | 0 | 0                          | 0    | 4     | 0 | 0                          | 0    | 1     | 0 | 0     | 0             | 9  | 90 |
| 4:50 PM                         | 0                       | 1    | 0     | 0 | 0                       | 2    | 0     | 0 | 0                          | 0    | 4     | 0 | 0                          | 0    | 0     | 1 | 0     | 0             | 8  | 85 |
| 4:55 PM                         | 0                       | 0    | 0     | 0 | 0                       | 0    | 0     | 0 | 0                          | 0    | 2     | 0 | 0                          | 0    | 2     | 0 | 0     | 0             | 4  | 84 |
| 5:00 PM                         | 0                       | 2    | 0     | 0 | 0                       | 1    | 0     | 0 | 0                          | 0    | 1     | 0 | 0                          | 1    | 4     | 0 | 0     | 0             | 9  | 83 |
| 5:05 PM                         | 0                       | 0    | 0     | 0 | 0                       | 0    | 0     | 0 | 0                          | 0    | 0     | 0 | 0                          | 1    | 2     | 0 | 0     | 0             | 3  | 84 |
| 5:10 PM                         | 0                       | 0    | 0     | 0 | 0                       | 0    | 0     | 0 | 0                          | 0    | 1     | 0 | 0                          | 1    | 2     | 0 | 0     | 0             | 4  | 80 |
| 5:15 PM                         | 0                       | 1    | 1     | 0 | 0                       | 0    | 0     | 0 | 0                          | 0    | 2     | 0 | 0                          | 0    | 1     | 0 | 0     | 0             | 5  | 83 |
| 5:20 PM                         | 0                       | 0    | 0     | 0 | 1                       | 0    | 0     | 0 | 0                          | 0    | 1     | 0 | 0                          | 0    | 2     | 0 | 0     | 0             | 4  | 82 |
| 5:25 PM                         | 0                       | 2    | 0     | 0 | 0                       | 0    | 0     | 0 | 0                          | 0    | 2     | 0 | 0                          | 0    | 2     | 2 | 0     | 0             | 8  | 74 |
| 5:30 PM                         | 0                       | 0    | 1     | 0 | 1                       | 0    | 1     | 0 | 0                          | 0    | 0     | 0 | 0                          | 0    | 0     | 1 | 0     | 0             | 4  | 69 |
| 5:35 PM                         | 0                       | 0    | 3     | 0 | 0                       | 2    | 0     | 0 | 0                          | 1    | 2     | 0 | 0                          | 0    | 3     | 0 | 0     | 0             | 11 | 75 |
| 5:40 PM                         | 0                       | 1    | 1     | 0 | 0                       | 0    | 0     | 0 | 0                          | 0    | 0     | 0 | 0                          | 0    | 2     | 0 | 0     | 0             | 4  | 73 |
| 5:45 PM                         | 0                       | 0    | 1     | 0 | 0                       | 0    | 0     | 0 | 0                          | 0    | 1     | 0 | 0                          | 0    | 3     | 0 | 0     | 0             | 5  | 69 |
| 5:50 PM                         | 0                       | 0    | 0     | 0 | 0                       | 0    | 0     | 0 | 0                          | 0    | 0     | 2 | 0                          | 1    | 2     | 0 | 0     | 0             | 5  | 66 |
| 5:55 PM                         | 0                       | 0    | 0     | 0 | 0                       | 0    | 0     | 0 | 0                          | 0    | 2     | 0 | 0                          | 0    | 1     | 1 | 0     | 0             | 4  | 66 |
| 6:00 PM                         | 0                       | 0    | 0     | 0 | 1                       | 0    | 0     | 0 | 0                          | 0    | 0     | 1 | 0                          | 1    | 2     | 0 | 0     | 0             | 5  | 62 |
| 6:05 PM                         | 0                       | 0    | 0     | 0 | 0                       | 0    | 0     | 0 | 0                          | 0    | 4     | 0 | 0                          | 1    | 0     | 0 | 0     | 0             | 5  | 64 |
| 6:10 PM                         | 0                       | 0    | 0     | 0 | 0                       | 0    | 0     | 0 | 0                          | 0    | 2     | 0 | 0                          | 0    | 1     | 1 | 0     | 0             | 4  | 64 |
| 6:15 PM                         | 0                       | 0    | 0     | 0 | 1                       | 0    | 0     | 0 | 0                          | 0    | 2     | 0 | 0                          | 1    | 0     | 0 | 0     | 0             | 4  | 63 |
| 6:20 PM                         | 0                       | 0    | 0     | 0 | 1                       | 0    | 0     | 0 | 0                          | 0    | 0     | 0 | 0                          | 0    | 1     | 0 | 0     | 0             | 2  | 61 |
| 6:25 PM                         | 0                       | 3    | 0     | 0 | 0                       | 0    | 0     | 0 | 0                          | 0    | 1     | 0 | 0                          | 0    | 3     | 0 | 0     | 0             | 7  | 60 |
| 6:30 PM                         | 0                       | 0    | 0     | 0 | 0                       | 0    | 0     | 0 | 0                          | 1    | 2     | 0 | 0                          | 0    | 1     | 0 | 0     | 0             | 4  | 60 |
| 6:35 PM                         | 0                       | 0    | 0     | 0 | 1                       | 1    | 0     | 0 | 0                          | 0    | 1     | 0 | 0                          | 0    | 1     | 0 | 0     | 0             | 4  | 53 |
| 6:40 PM                         | 0                       | 0    | 0     | 0 | 0                       | 0    | 0     | 0 | 0                          | 0    | 0     | 0 | 0                          | 2    | 2     | 0 | 0     | 0             | 4  | 53 |
| 6:45 PM                         | 0                       | 0    | 0     | 0 | 0                       | 0    | 0     | 0 | 0                          | 0    | 0     | 0 | 0                          | 0    | 4     | 0 | 0     | 0             | 4  | 52 |
| 6:50 PM                         | 0                       | 1    | 0     | 0 | 0                       | 0    | 0     | 0 | 0                          | 0    | 1     | 0 | 0                          | 0    | 0     | 0 | 0     | 0             | 2  | 49 |
| 6:55 PM                         | 0                       | 0    | 0     | 0 | 0                       | 0    | 0     | 0 | 0                          | 0    | 2     | 0 | 0                          | 0    | 0     | 0 | 0     | 0             | 2  | 47 |
| 7:00 PM                         | 0                       | 0    | 0     | 0 | 0                       | 0    | 0     | 0 | 0                          | 0    | 0     | 0 | 0                          | 1    | 1     | 0 | 0     | 0             | 2  | 44 |
| 7:05 PM                         | 0                       | 0    | 0     | 0 | 0                       | 0    | 0     | 0 | 0                          | 0    | 1     | 0 | 0                          | 0    | 1     | 0 | 0     | 0             | 2  | 41 |
| 7:10 PM                         | 0                       | 0    | 0     | 0 | 0                       | 0    | 0     | 0 | 0                          | 0    | 1     | 0 | 0                          | 0    | 2     | 1 | 0     | 0             | 4  | 41 |
| 7:15 PM                         | 0                       | 0    | 0     | 0 | 0                       | 0    | 0     | 0 | 0                          | 0    | 0     | 0 | 0                          | 0    | 3     | 0 | 0     | 0             | 3  | 40 |
| 7:20 PM                         | 0                       | 0    | 0     | 0 | 1                       | 0    | 0     | 0 | 0                          | 0    | 0     | 0 | 0                          | 0    | 1     | 0 | 0     | 0             | 2  | 40 |
| 7:25 PM                         | 0                       | 0    | 0     | 0 | 0                       | 0    | 0     | 0 | 0                          | 0    | 0     | 0 | 0                          | 1    | 2     | 1 | 0     | 0             | 4  | 37 |
| 7:30 PM                         | 0                       | 0    | 0     | 0 | 0                       | 0    | 0     | 0 | 0                          | 0    | 1     | 0 | 0                          | 2    | 5     | 1 | 0     | 0             | 9  | 42 |
| 7:35 PM                         | 0                       | 0    | 0     | 0 | 0                       | 0    | 0     | 0 | 0                          | 0    | 2     | 0 | 0                          | 1    | 0     | 0 | 0     | 0             | 3  | 41 |
| 7:40 PM                         | 0                       | 0    | 1     | 0 | 0                       | 0    | 0     | 0 | 0                          | 1    | 0     | 0 | 0                          | 0    | 2     | 0 | 0     | 0             | 4  | 41 |
| 7:45 PM                         | 0                       | 0    | 0     | 0 | 1                       | 0    | 0     | 0 | 0                          | 0    | 3     | 0 | 0                          | 1    | 0     | 1 | 0     | 0             | 6  | 43 |
| 7:50 PM                         | 0                       | 0    | 0     | 0 | 1                       | 0    | 0     | 0 | 0                          | 0    | 0     | 0 | 0                          | 0    | 1     | 0 | 0     | 0             | 2  | 43 |
| 7:55 PM                         | 0                       | 0    | 0     | 0 | 0                       | 0    | 0     | 0 | 0                          | 0    | 0     | 0 | 0                          | 0    | 0     | 0 | 0     | 0             | 0  | 41 |
| 8:00 PM                         | 0                       | 0    | 0     | 0 | 0                       | 0    | 0     | 0 | 0                          | 0    | 1     | 0 | 0                          | 0    | 2     | 0 | 0     | 0             | 3  | 42 |
| 8:05 PM                         | 0                       | 0    | 0     | 0 | 0                       | 0    | 0     | 0 | 0                          | 0    | 0     | 0 | 0                          | 0    | 1     | 0 | 0     | 0             | 1  | 41 |
| 8:10 PM                         | 0                       | 0    | 0     | 0 | 0                       | 0    | 0     | 0 | 0                          | 0    | 1     | 0 | 0                          | 0    | 0     | 2 | 0     | 0             | 3  | 40 |
| 8:15 PM                         | 0                       | 0    | 0     | 0 | 0                       | 0    | 0     | 0 | 0                          | 0    | 1     | 0 | 0                          | 0    | 0     | 0 | 0     | 0             | 1  | 38 |
| 8:20 PM                         | 0                       | 0    | 0     | 0 | 0                       | 0    | 0     | 0 | 0                          | 0    | 0     | 0 | 0                          | 0    | 0     | 1 | 0     | 0             | 1  | 37 |
| 8:25 PM                         | 0                       | 0    | 0     | 0 | 0                       | 0    | 0     | 0 | 0                          | 0    | 1     | 0 | 0                          | 1    | 0     | 1 | 0     | 0             | 3  | 36 |
| 8:30 PM                         | 0                       | 0    | 0     | 0 | 0                       | 0    | 0     | 0 | 0                          | 0    | 1     | 0 | 0                          | 0    | 0     | 2 | 0     | 0             | 3  | 30 |
| 8:35 PM                         | 0                       | 0    | 0     | 0 | 0                       | 1    | 0     | 0 | 0                          | 0    | 0     | 0 | 0                          | 0    | 2     | 0 | 0     | 0             | 3  | 30 |
| 8:40 PM                         | 0                       | 1    | 0     | 0 | 0                       | 0    | 0     | 0 | 0                          | 0    | 0     | 0 | 0                          | 0    | 0     | 1 | 0     | 0             | 2  | 28 |
| 8:45 PM                         | 0                       | 0    | 0     | 0 | 0                       | 0    | 0     | 0 | 0                          | 0    | 0     | 0 | 0                          | 0    | 1     | 1 | 0     | 0             | 2  | 24 |
| 8:50 PM                         | 0                       | 0    | 0     | 0 | 0                       | 1    | 0     | 0 | 0                          | 0    | 0     | 0 | 0                          | 0    | 2     | 1 | 0     | 0             | 4  | 26 |
| 8:55 PM                         | 0                       | 0    | 0     | 0 | 0                       | 0    | 0     | 0 | 0                          | 0    | 1     | 0 | 0                          | 0    | 1     | 0 | 0     | 0             | 2  | 28 |
| 9:00 PM                         | 0                       | 0    | 2     | 0 | 0                       | 0    | 0     | 0 | 0                          | 0    | 0     | 0 | 0                          | 0    | 1     | 0 | 0     | 0             | 3  | 28 |
| 9:05 PM                         | 0                       | 0    | 0     | 0 | 0                       | 0    | 0     | 0 | 0                          | 0    | 0     | 0 | 0                          | 0    | 2     | 0 | 0     | 0             | 2  | 29 |
| 9:10 PM                         | 0                       | 0    | 0     | 0 | 0                       | 1    | 0     | 0 | 0                          | 0    | 0     | 0 | 0                          | 0    | 1     | 0 | 0     | 0             | 2  | 28 |
| 9:15 PM                         | 0                       | 0    | 0     | 0 | 0                       | 0    | 0     | 0 | 0                          | 0    | 0     | 0 | 0                          | 0    | 1     | 0 | 0     | 0             | 1  | 28 |
| 9:20 PM                         | 0                       | 0    | 0     | 0 | 0                       | 0    | 0     | 0 | 0                          | 0    | 0     | 0 | 0                          | 0    | 0     | 0 | 0     | 0             | 0  | 27 |
| 9:25 PM                         | 0                       | 0    | 0     | 0 | 0                       | 0    | 0     | 0 | 0                          | 0    | 1     | 0 | 0                          | 0    | 3     | 0 | 0     | 0             | 4  | 28 |
| 9:30 PM                         | 0                       | 0    | 0     | 0 | 0                       | 0    | 0     | 0 | 0                          | 0    | 0     | 0 | 0                          | 0    | 0     | 0 | 0     | 0             | 0  | 25 |
| 9:35 PM                         | 0                       | 0    | 0     | 0 | 0                       | 0    | 0     | 0 | 0                          | 0    | 0     | 0 | 0                          | 0    | 1     | 0 | 0     | 0             | 1  | 23 |
| 9:40 PM                         | 0                       | 0    | 0     | 0 | 0                       | 0    | 0     | 0 | 0                          | 0    | 0     | 0 | 0                          | 0    | 0     | 0 | 0     | 0             | 0  | 21 |
| 9:45 PM                         | 0                       | 0    | 0     | 0 | 0                       | 0    | 0     | 0 | 0                          | 0    | 0     | 0 | 0                          | 0    | 0     | 0 | 0     | 0             | 0  | 19 |
| 9:50 PM                         | 0                       | 0    | 0     | 0 | 0                       | 0    | 0     | 0 | 0                          | 0    | 0     | 0 | 0                          | 0    | 0     | 0 | 0     | 0             | 0  | 15 |
| 9:55 PM                         | 0                       | 0    | 0     | 0 | 0                       | 0    | 0     | 0 | 0                          | 0    | 1     | 0 | 0                          | 0    | 1     | 0 | 0     | 0             | 2  | 15 |
| Peak 15-Min Flowrates           | Northbound              |      |       |   | Southbound              |      |       |   | Eastbound                  |      |       |   | Westbound                  |      |       |   | Total |               |    |    |
|                                 | Left                    | Thru | Right | U | Left                    | Thru | Right | U | Left                       | Thru | Right | U | Left                       | Thru | Right | U |       |               |    |    |
| All Vehicles                    | 20                      | 96   | 44    | 0 | 68                      | 68   | 8     | 0 | 12                         | 124  | 12    | 0 | 4                          | 0    | 0     | 0 | 0     | 456           |    |    |
| Heavy Trucks                    | 4                       | 0    | 0     | 0 | 0                       | 0    | 0     | 0 | 0                          | 0    | 0     | 0 | 0                          | 0    | 0     | 0 | 0     | 4             |    |    |
| Buses                           |                         | 52   |       |   |                         | 0    |       |   |                            | 20   |       |   |                            | 0    |       |   |       | 72            |    |    |
| Pedestrians                     | 0                       | 0    | 0     | 0 | 0                       | 0    | 0     | 0 | 0                          | 12   | 4     | 0 | 0                          | 0    | 0     | 0 | 0     | 16            |    |    |
| Bicycles                        |                         |      |       |   |                         |      |       |   |                            |      |       |   |                            |      |       |   |       |               |    |    |
| Scoters                         |                         |      |       |   |                         |      |       |   |                            |      |       |   |                            |      |       |   |       |               |    |    |

Comments:

LOCATION: Silver Fox Rd -- Druid Ln  
 CITY/STATE: Rossmoor, CA

QC JOB #: 16966413  
 DATE: Wed, Apr 9 2025

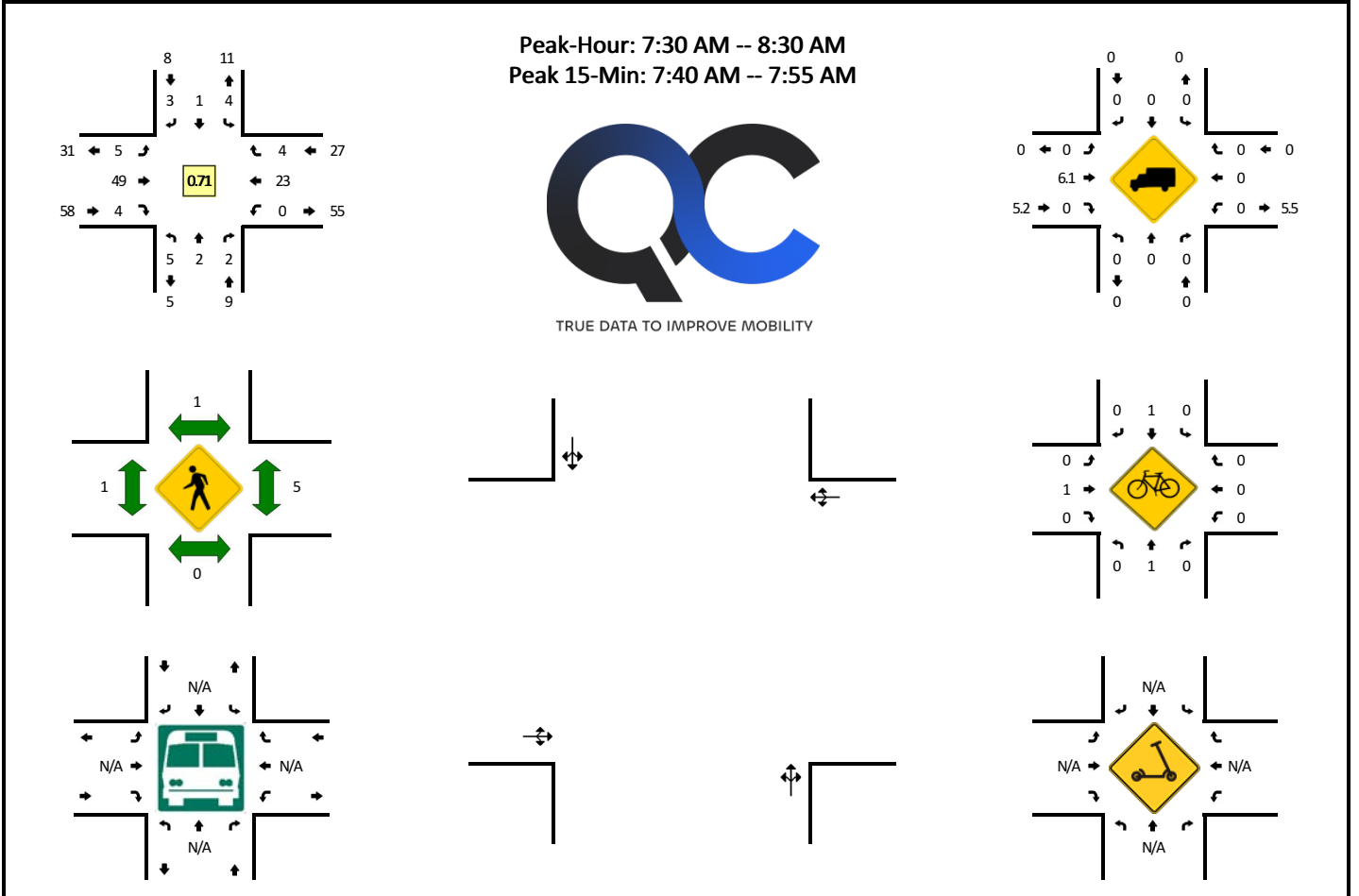

| 5-Min Count Period Beginning At | Silver Fox Rd (Northbound) |      |       |   | Silver Fox Rd (Southbound) |      |       |   | Druid Ln (Eastbound) |      |       |   | Druid Ln (Westbound) |      |       |   | Total | Hourly Totals |
|---------------------------------|----------------------------|------|-------|---|----------------------------|------|-------|---|----------------------|------|-------|---|----------------------|------|-------|---|-------|---------------|
|                                 | Left                       | Thru | Right | U | Left                       | Thru | Right | U | Left                 | Thru | Right | U | Left                 | Thru | Right | U |       |               |
| 6:00 AM                         | 0                          | 0    | 0     | 0 | 0                          | 0    | 0     | 0 | 0                    | 0    | 0     | 0 | 0                    | 0    | 0     | 0 | 0     | 0             |
| 6:05 AM                         | 0                          | 0    | 0     | 0 | 0                          | 0    | 0     | 0 | 0                    | 0    | 1     | 0 | 0                    | 0    | 0     | 0 | 0     | 0             |
| 6:10 AM                         | 0                          | 0    | 0     | 0 | 0                          | 0    | 0     | 0 | 0                    | 0    | 0     | 0 | 0                    | 0    | 0     | 0 | 0     | 0             |
| 6:15 AM                         | 0                          | 0    | 0     | 0 | 0                          | 0    | 0     | 0 | 0                    | 0    | 0     | 0 | 0                    | 0    | 0     | 0 | 0     | 0             |
| 6:20 AM                         | 0                          | 0    | 0     | 0 | 0                          | 0    | 0     | 0 | 0                    | 0    | 1     | 1 | 0                    | 0    | 1     | 0 | 0     | 3             |
| 6:25 AM                         | 0                          | 0    | 0     | 0 | 0                          | 0    | 0     | 0 | 0                    | 0    | 1     | 0 | 0                    | 0    | 1     | 0 | 0     | 2             |
| 6:30 AM                         | 0                          | 0    | 0     | 0 | 1                          | 0    | 0     | 0 | 0                    | 0    | 3     | 0 | 0                    | 0    | 0     | 0 | 0     | 4             |
| 6:35 AM                         | 0                          | 0    | 0     | 0 | 1                          | 0    | 0     | 0 | 0                    | 0    | 2     | 0 | 0                    | 0    | 0     | 0 | 0     | 3             |
| 6:40 AM                         | 0                          | 0    | 0     | 0 | 0                          | 0    | 0     | 0 | 0                    | 0    | 2     | 0 | 0                    | 0    | 0     | 0 | 0     | 2             |
| 6:45 AM                         | 0                          | 0    | 0     | 0 | 0                          | 1    | 1     | 0 | 0                    | 0    | 2     | 0 | 0                    | 0    | 1     | 0 | 0     | 5             |
| 6:50 AM                         | 0                          | 0    | 0     | 0 | 0                          | 0    | 0     | 0 | 0                    | 0    | 0     | 0 | 0                    | 0    | 0     | 0 | 0     | 0             |
| 6:55 AM                         | 1                          | 0    | 0     | 0 | 0                          | 0    | 0     | 0 | 0                    | 0    | 0     | 0 | 0                    | 0    | 0     | 0 | 0     | 1             |
| 7:00 AM                         | 0                          | 0    | 0     | 0 | 0                          | 0    | 0     | 0 | 0                    | 0    | 2     | 0 | 0                    | 0    | 0     | 0 | 0     | 2             |
| 7:05 AM                         | 0                          | 0    | 0     | 0 | 0                          | 0    | 0     | 0 | 0                    | 0    | 1     | 0 | 0                    | 0    | 1     | 0 | 0     | 2             |
| 7:10 AM                         | 0                          | 0    | 0     | 0 | 0                          | 1    | 0     | 0 | 0                    | 0    | 3     | 0 | 0                    | 0    | 3     | 0 | 0     | 7             |
| 7:15 AM                         | 0                          | 1    | 0     | 0 | 0                          | 1    | 0     | 0 | 0                    | 0    | 1     | 0 | 0                    | 0    | 1     | 1 | 0     | 5             |
| 7:20 AM                         | 0                          | 0    | 1     | 0 | 0                          | 0    | 0     | 0 | 0                    | 0    | 3     | 0 | 0                    | 0    | 0     | 0 | 0     | 4             |
| 7:25 AM                         | 0                          | 0    | 0     | 0 | 0                          | 0    | 0     | 0 | 0                    | 0    | 0     | 0 | 0                    | 0    | 1     | 1 | 0     | 2             |
| 7:30 AM                         | 0                          | 0    | 0     | 0 | 0                          | 0    | 0     | 0 | 0                    | 1    | 4     | 0 | 0                    | 0    | 3     | 0 | 0     | 8             |
| 7:35 AM                         | 0                          | 0    | 0     | 0 | 0                          | 0    | 0     | 0 | 0                    | 0    | 4     | 0 | 0                    | 0    | 0     | 0 | 0     | 4             |
| 7:40 AM                         | 1                          | 0    | 0     | 0 | 1                          | 0    | 1     | 0 | 0                    | 1    | 3     | 0 | 0                    | 0    | 1     | 1 | 0     | 9             |
| 7:45 AM                         | 2                          | 0    | 0     | 0 | 0                          | 0    | 0     | 0 | 0                    | 0    | 4     | 1 | 0                    | 0    | 1     | 0 | 0     | 8             |
| 7:50 AM                         | 1                          | 1    | 0     | 0 | 0                          | 0    | 0     | 0 | 0                    | 0    | 8     | 0 | 0                    | 0    | 8     | 1 | 0     | 19            |
| 7:55 AM                         | 0                          | 0    | 0     | 0 | 0                          | 0    | 1     | 0 | 0                    | 0    | 2     | 0 | 0                    | 0    | 1     | 0 | 0     | 4             |
| 8:00 AM                         | 1                          | 0    | 0     | 0 | 1                          | 0    | 0     | 0 | 0                    | 1    | 6     | 0 | 0                    | 0    | 3     | 1 | 0     | 13            |
| 8:05 AM                         | 0                          | 0    | 1     | 0 | 1                          | 0    | 1     | 0 | 0                    | 0    | 4     | 0 | 0                    | 0    | 1     | 0 | 0     | 8             |
| 8:10 AM                         | 0                          | 0    | 1     | 0 | 1                          | 0    | 0     | 0 | 0                    | 1    | 4     | 1 | 0                    | 0    | 0     | 0 | 0     | 8             |
| 8:15 AM                         | 0                          | 1    | 0     | 0 | 0                          | 1    | 0     | 0 | 0                    | 0    | 4     | 2 | 0                    | 0    | 2     | 0 | 0     | 10            |
| 8:20 AM                         | 0                          | 0    | 0     | 0 | 0                          | 0    | 0     | 0 | 0                    | 0    | 4     | 0 | 0                    | 0    | 1     | 1 | 0     | 6             |
| 8:25 AM                         | 0                          | 0    | 0     | 0 | 0                          | 0    | 0     | 0 | 0                    | 1    | 2     | 0 | 0                    | 0    | 2     | 0 | 0     | 5             |
| 8:30 AM                         | 0                          | 0    | 0     | 0 | 0                          | 0    | 0     | 0 | 0                    | 0    | 2     | 0 | 0                    | 0    | 2     | 1 | 0     | 5             |
| 8:35 AM                         | 0                          | 0    | 0     | 0 | 1                          | 0    | 0     | 0 | 0                    | 0    | 4     | 0 | 0                    | 0    | 0     | 0 | 0     | 5             |
| 8:40 AM                         | 0                          | 0    | 1     | 0 | 1                          | 0    | 0     | 0 | 0                    | 0    | 1     | 0 | 0                    | 0    | 1     | 0 | 0     | 4             |
| 8:45 AM                         | 0                          | 0    | 0     | 0 | 0                          | 0    | 0     | 0 | 0                    | 0    | 2     | 0 | 0                    | 0    | 1     | 0 | 0     | 3             |
| 8:50 AM                         | 1                          | 0    | 0     | 0 | 0                          | 0    | 1     | 0 | 0                    | 0    | 1     | 0 | 0                    | 0    | 3     | 0 | 0     | 6             |
| 8:55 AM                         | 0                          | 0    | 0     | 0 | 0                          | 0    | 0     | 0 | 0                    | 0    | 3     | 0 | 0                    | 0    | 0     | 0 | 0     | 3             |
| 9:00 AM                         | 0                          | 0    | 0     | 0 | 2                          | 0    | 0     | 0 | 0                    | 0    | 2     | 0 | 0                    | 0    | 1     | 0 | 0     | 5             |
| 9:05 AM                         | 0                          | 0    | 0     | 0 | 0                          | 0    | 0     | 0 | 0                    | 0    | 2     | 0 | 0                    | 0    | 0     | 0 | 0     | 2             |

**Attachment B**

| 5-Min Count Period Beginning At | Silver Fox Rd (Northbound) |      |       |   | Silver Fox Rd (Southbound) |      |       |   | Druid Ln (Eastbound) |      |       |   | Druid Ln (Westbound) |      |       |   | Total | Hourly Totals |    |
|---------------------------------|----------------------------|------|-------|---|----------------------------|------|-------|---|----------------------|------|-------|---|----------------------|------|-------|---|-------|---------------|----|
|                                 | Left                       | Thru | Right | U | Left                       | Thru | Right | U | Left                 | Thru | Right | U | Left                 | Thru | Right | U |       |               |    |
| 9:10 AM                         | 0                          | 0    | 0     | 0 | 0                          | 0    | 0     | 0 | 0                    | 4    | 0     | 0 | 0                    | 0    | 0     | 0 | 4     | 58            |    |
| 9:15 AM                         | 0                          | 0    | 0     | 0 | 0                          | 1    | 1     | 0 | 0                    | 4    | 0     | 0 | 0                    | 0    | 1     | 1 | 0     | 8             | 56 |
| 9:20 AM                         | 0                          | 2    | 0     | 0 | 0                          | 0    | 0     | 0 | 0                    | 0    | 0     | 0 | 0                    | 0    | 0     | 0 | 2     | 52            |    |
| 9:25 AM                         | 0                          | 0    | 0     | 0 | 0                          | 0    | 0     | 0 | 0                    | 0    | 0     | 0 | 0                    | 1    | 0     | 0 | 1     | 48            |    |
| 9:30 AM                         | 0                          | 0    | 0     | 0 | 0                          | 0    | 0     | 0 | 0                    | 3    | 0     | 0 | 0                    | 0    | 1     | 0 | 4     | 47            |    |
| 9:35 AM                         | 0                          | 0    | 0     | 0 | 0                          | 0    | 1     | 0 | 0                    | 4    | 0     | 0 | 0                    | 1    | 1     | 0 | 7     | 49            |    |
| 9:40 AM                         | 0                          | 0    | 0     | 0 | 0                          | 0    | 0     | 0 | 0                    | 2    | 0     | 0 | 0                    | 0    | 1     | 0 | 3     | 48            |    |
| 9:45 AM                         | 0                          | 1    | 0     | 0 | 0                          | 0    | 0     | 0 | 0                    | 2    | 0     | 0 | 0                    | 1    | 1     | 0 | 5     | 50            |    |
| 9:50 AM                         | 0                          | 0    | 0     | 0 | 0                          | 0    | 0     | 0 | 0                    | 2    | 0     | 0 | 0                    | 0    | 0     | 0 | 2     | 46            |    |
| 9:55 AM                         | 1                          | 0    | 0     | 0 | 0                          | 0    | 0     | 0 | 0                    | 1    | 0     | 0 | 0                    | 0    | 0     | 0 | 2     | 45            |    |
| 10:00 AM                        | 0                          | 0    | 1     | 0 | 0                          | 0    | 0     | 0 | 0                    | 1    | 0     | 0 | 0                    | 0    | 0     | 0 | 2     | 42            |    |
| 10:05 AM                        | 0                          | 0    | 0     | 0 | 0                          | 0    | 0     | 0 | 0                    | 2    | 0     | 0 | 0                    | 0    | 1     | 0 | 3     | 43            |    |
| 10:10 AM                        | 0                          | 0    | 0     | 0 | 0                          | 1    | 1     | 0 | 0                    | 2    | 0     | 0 | 0                    | 0    | 1     | 0 | 5     | 44            |    |
| 10:15 AM                        | 0                          | 1    | 0     | 0 | 0                          | 1    | 0     | 0 | 0                    | 2    | 0     | 0 | 1                    | 0    | 0     | 0 | 5     | 41            |    |
| 10:20 AM                        | 0                          | 0    | 0     | 0 | 0                          | 0    | 0     | 0 | 0                    | 2    | 0     | 0 | 0                    | 0    | 0     | 0 | 2     | 41            |    |
| 10:25 AM                        | 0                          | 0    | 0     | 0 | 0                          | 0    | 0     | 0 | 0                    | 1    | 1     | 0 | 0                    | 0    | 0     | 0 | 2     | 42            |    |
| 10:30 AM                        | 0                          | 0    | 0     | 0 | 0                          | 2    | 0     | 0 | 0                    | 1    | 0     | 0 | 1                    | 1    | 0     | 0 | 5     | 43            |    |
| 10:35 AM                        | 0                          | 0    | 0     | 0 | 0                          | 0    | 0     | 0 | 0                    | 0    | 0     | 0 | 0                    | 1    | 2     | 0 | 3     | 39            |    |
| 10:40 AM                        | 0                          | 0    | 0     | 0 | 0                          | 0    | 0     | 0 | 0                    | 4    | 0     | 0 | 0                    | 2    | 0     | 0 | 6     | 42            |    |
| 10:45 AM                        | 0                          | 0    | 1     | 0 | 0                          | 0    | 0     | 0 | 0                    | 1    | 0     | 0 | 0                    | 2    | 0     | 0 | 4     | 41            |    |
| 10:50 AM                        | 0                          | 0    | 1     | 0 | 0                          | 0    | 1     | 0 | 0                    | 0    | 0     | 0 | 0                    | 1    | 1     | 0 | 4     | 43            |    |
| 10:55 AM                        | 0                          | 0    | 0     | 0 | 0                          | 0    | 0     | 0 | 0                    | 2    | 0     | 0 | 0                    | 1    | 0     | 0 | 3     | 44            |    |
| 11:00 AM                        | 0                          | 2    | 0     | 0 | 0                          | 0    | 0     | 0 | 0                    | 3    | 0     | 0 | 0                    | 1    | 0     | 0 | 6     | 48            |    |
| 11:05 AM                        | 0                          | 0    | 0     | 0 | 0                          | 0    | 0     | 0 | 0                    | 1    | 0     | 0 | 0                    | 0    | 0     | 0 | 1     | 46            |    |
| 11:10 AM                        | 0                          | 0    | 0     | 0 | 0                          | 0    | 0     | 0 | 0                    | 0    | 0     | 0 | 0                    | 0    | 0     | 0 | 0     | 41            |    |
| 11:15 AM                        | 0                          | 1    | 0     | 0 | 1                          | 0    | 0     | 0 | 0                    | 2    | 0     | 0 | 0                    | 2    | 0     | 0 | 6     | 42            |    |
| 11:20 AM                        | 0                          | 1    | 0     | 0 | 0                          | 0    | 0     | 0 | 0                    | 4    | 0     | 0 | 1                    | 3    | 0     | 0 | 9     | 49            |    |
| 11:25 AM                        | 1                          | 1    | 0     | 0 | 0                          | 0    | 2     | 0 | 0                    | 1    | 0     | 0 | 0                    | 0    | 1     | 0 | 6     | 53            |    |
| 11:30 AM                        | 0                          | 0    | 0     | 0 | 0                          | 0    | 0     | 0 | 0                    | 3    | 0     | 0 | 0                    | 1    | 0     | 0 | 4     | 52            |    |
| 11:35 AM                        | 0                          | 1    | 0     | 0 | 0                          | 0    | 0     | 0 | 0                    | 2    | 0     | 0 | 0                    | 5    | 0     | 0 | 8     | 57            |    |
| 11:40 AM                        | 0                          | 0    | 0     | 0 | 1                          | 0    | 0     | 0 | 0                    | 2    | 0     | 0 | 0                    | 0    | 0     | 0 | 3     | 54            |    |
| 11:45 AM                        | 0                          | 0    | 0     | 0 | 0                          | 0    | 0     | 0 | 0                    | 2    | 0     | 0 | 0                    | 2    | 0     | 0 | 4     | 54            |    |
| 11:50 AM                        | 0                          | 0    | 0     | 0 | 0                          | 0    | 0     | 0 | 0                    | 2    | 0     | 0 | 0                    | 2    | 0     | 0 | 4     | 54            |    |
| 11:55 AM                        | 0                          | 0    | 0     | 0 | 0                          | 0    | 0     | 0 | 0                    | 0    | 0     | 0 | 0                    | 0    | 0     | 0 | 0     | 51            |    |
| 12:00 PM                        | 0                          | 0    | 1     | 0 | 0                          | 0    | 0     | 0 | 0                    | 2    | 0     | 0 | 0                    | 0    | 0     | 0 | 3     | 48            |    |
| 12:05 PM                        | 0                          | 0    | 0     | 0 | 0                          | 0    | 0     | 0 | 0                    | 1    | 0     | 0 | 0                    | 1    | 0     | 0 | 2     | 49            |    |
| 12:10 PM                        | 0                          | 0    | 1     | 0 | 0                          | 1    | 0     | 0 | 0                    | 3    | 0     | 0 | 0                    | 0    | 0     | 0 | 5     | 54            |    |
| 12:15 PM                        | 0                          | 0    | 0     | 0 | 0                          | 0    | 0     | 0 | 0                    | 3    | 0     | 0 | 0                    | 1    | 0     | 0 | 4     | 52            |    |
| 12:20 PM                        | 0                          | 0    | 0     | 0 | 0                          | 0    | 1     | 0 | 0                    | 0    | 0     | 0 | 0                    | 2    | 0     | 0 | 3     | 46            |    |
| 12:25 PM                        | 0                          | 0    | 0     | 0 | 0                          | 0    | 0     | 0 | 1                    | 0    | 0     | 0 | 0                    | 0    | 0     | 0 | 1     | 41            |    |
| 12:30 PM                        | 0                          | 0    | 0     | 0 | 0                          | 0    | 0     | 0 | 0                    | 1    | 0     | 0 | 0                    | 1    | 0     | 0 | 2     | 39            |    |
| 12:35 PM                        | 0                          | 0    | 0     | 0 | 0                          | 0    | 0     | 0 | 0                    | 2    | 0     | 0 | 0                    | 1    | 0     | 0 | 3     | 34            |    |
| 12:40 PM                        | 0                          | 0    | 0     | 0 | 0                          | 0    | 0     | 0 | 0                    | 4    | 0     | 0 | 0                    | 1    | 0     | 0 | 5     | 36            |    |
| 12:45 PM                        | 1                          | 0    | 0     | 0 | 0                          | 0    | 0     | 0 | 0                    | 2    | 0     | 0 | 0                    | 0    | 0     | 0 | 3     | 35            |    |
| 12:50 PM                        | 0                          | 1    | 0     | 0 | 0                          | 0    | 0     | 0 | 0                    | 2    | 0     | 0 | 0                    | 2    | 0     | 0 | 5     | 36            |    |
| 12:55 PM                        | 0                          | 0    | 0     | 0 | 0                          | 0    | 0     | 0 | 0                    | 1    | 0     | 0 | 0                    | 1    | 0     | 0 | 2     | 38            |    |
| 1:00 PM                         | 0                          | 0    | 0     | 0 | 0                          | 0    | 0     | 0 | 0                    | 2    | 0     | 0 | 0                    | 1    | 0     | 0 | 3     | 38            |    |
| 1:05 PM                         | 0                          | 0    | 0     | 0 | 0                          | 0    | 1     | 0 | 0                    | 0    | 1     | 0 | 0                    | 2    | 0     | 0 | 4     | 40            |    |
| 1:10 PM                         | 0                          | 0    | 0     | 0 | 1                          | 0    | 0     | 0 | 1                    | 0    | 0     | 0 | 0                    | 3    | 1     | 0 | 6     | 41            |    |
| 1:15 PM                         | 0                          | 0    | 0     | 0 | 0                          | 0    | 0     | 0 | 0                    | 1    | 0     | 0 | 0                    | 1    | 1     | 0 | 3     | 40            |    |
| 1:20 PM                         | 0                          | 0    | 0     | 0 | 0                          | 0    | 0     | 0 | 1                    | 3    | 1     | 0 | 0                    | 3    | 0     | 0 | 8     | 45            |    |
| 1:25 PM                         | 0                          | 0    | 0     | 0 | 0                          | 1    | 0     | 0 | 0                    | 1    | 0     | 0 | 1                    | 0    | 0     | 0 | 3     | 47            |    |
| 1:30 PM                         | 0                          | 0    | 0     | 0 | 0                          | 0    | 0     | 0 | 0                    | 4    | 2     | 0 | 0                    | 3    | 1     | 0 | 10    | 55            |    |
| 1:35 PM                         | 0                          | 1    | 0     | 0 | 0                          | 0    | 0     | 0 | 0                    | 5    | 0     | 0 | 0                    | 3    | 1     | 0 | 10    | 62            |    |
| 1:40 PM                         | 0                          | 0    | 0     | 0 | 1                          | 0    | 0     | 0 | 0                    | 6    | 0     | 0 | 0                    | 1    | 0     | 0 | 8     | 65            |    |
| 1:45 PM                         | 1                          | 0    | 0     | 0 | 0                          | 0    | 0     | 0 | 1                    | 3    | 0     | 0 | 0                    | 1    | 1     | 0 | 7     | 69            |    |
| 1:50 PM                         | 0                          | 1    | 0     | 0 | 0                          | 0    | 0     | 0 | 0                    | 3    | 0     | 0 | 1                    | 2    | 0     | 0 | 7     | 71            |    |
| 1:55 PM                         | 0                          | 1    | 0     | 0 | 0                          | 1    | 1     | 0 | 0                    | 0    | 1     | 0 | 0                    | 1    | 0     | 0 | 5     | 74            |    |
| 2:00 PM                         | 0                          | 0    | 1     | 0 | 0                          | 0    | 0     | 0 | 0                    | 2    | 0     | 0 | 1                    | 2    | 0     | 0 | 6     | 77            |    |
| 2:05 PM                         | 0                          | 0    | 0     | 0 | 1                          | 0    | 0     | 0 | 0                    | 5    | 0     | 0 | 0                    | 2    | 0     | 0 | 8     | 81            |    |
| 2:10 PM                         | 0                          | 0    | 0     | 0 | 0                          | 0    | 0     | 0 | 0                    | 1    | 0     | 0 | 0                    | 2    | 0     | 0 | 3     | 78            |    |
| 2:15 PM                         | 0                          | 0    | 0     | 0 | 0                          | 0    | 0     | 0 | 0                    | 3    | 0     | 0 | 0                    | 1    | 0     | 0 | 4     | 79            |    |
| 2:20 PM                         | 1                          | 0    | 0     | 0 | 1                          | 1    | 0     | 0 | 0                    | 1    | 0     | 0 | 0                    | 0    | 1     | 0 | 5     | 76            |    |
| 2:25 PM                         | 0                          | 1    | 0     | 0 | 0                          | 0    | 0     | 0 | 0                    | 1    | 0     | 0 | 0                    | 3    | 0     | 0 | 5     | 78            |    |
| 2:30 PM                         | 1                          | 0    | 0     | 0 | 0                          | 1    | 0     | 0 | 0                    | 3    | 0     | 0 | 0                    | 2    | 0     | 0 | 7     | 75            |    |
| 2:35 PM                         | 0                          | 0    | 0     | 0 | 0                          | 0    | 1     | 0 | 0                    | 4    | 0     | 0 | 0                    | 2    | 2     | 0 | 9     | 74            |    |
| 2:40 PM                         | 0                          | 0    | 0     | 0 | 0                          | 0    | 0     | 0 | 0                    | 3    | 0     | 0 | 0                    | 4    | 0     | 0 | 7     | 73            |    |
| 2:45 PM                         | 0                          | 0    | 0     | 0 | 0                          | 2    | 0     | 0 | 0                    | 1    | 0     | 0 | 0                    | 3    | 0     | 0 | 6     | 72            |    |
| 2:50 PM                         | 1                          | 0    | 0     | 0 | 0                          | 0    | 0     | 0 | 0                    | 1    | 0     | 0 | 0                    | 1    | 0     | 0 | 3     | 68            |    |
| 2:55 PM                         | 0                          | 0    | 0     | 0 | 0                          | 0    | 0     | 0 | 0                    | 1    | 0     | 0 | 0                    | 3    | 1     | 0 | 5     | 68            |    |
| 3:00 PM                         | 0                          | 0    | 0     | 0 | 1                          | 1    | 0     | 0 | 0                    | 3    | 0     | 0 | 0                    | 3    | 0     | 0 | 8     | 70            |    |
| 3:05 PM                         | 0                          | 1    | 0     | 0 | 0                          | 0    | 0     | 0 | 0                    | 2    | 1     | 0 | 0                    | 0    | 0     | 0 | 4     | 66            |    |
| 3:10 PM                         | 0                          | 1    | 0     | 0 | 0                          | 0    | 0     | 0 | 0                    | 3    | 0     | 0 | 0                    | 3    | 0     | 0 | 7     | 70            |    |
| 3:15 PM                         | 0                          | 0    | 0     | 0 | 0                          | 0    | 1     | 0 | 0                    | 3    | 0     | 0 | 0                    | 2    | 0     | 0 | 6     | 72            |    |
| 3:20 PM                         | 0                          | 0    | 1     | 0 | 1                          | 0    | 0     | 0 | 0                    | 0    | 1     | 0 | 0                    | 0    | 0     | 0 | 3     | 70            |    |
| 3:25 PM                         | 0                          | 0    | 0     | 0 | 0                          | 0    | 0     | 0 | 0                    | 3    | 0     | 0 | 0                    | 2    | 0     | 0 | 5     | 70            |    |
| 3:30 PM                         | 0                          | 0    | 0     | 0 | 0                          | 0    | 0     | 0 | 0                    | 2    | 0     | 0 | 1                    | 1    | 0     | 0 | 4     | 67            |    |
| 3:35 PM                         | 0                          | 0    | 0     | 0 | 0                          | 0    | 0     | 0 | 0                    | 1    | 0     | 0 | 0                    | 4    | 0     | 0 | 5     | 63            |    |
| 3:40 PM                         | 0                          | 0    | 0     | 0 | 0                          | 0    | 1     | 0 | 1                    | 2    | 0     | 0 | 0                    | 1    | 0     | 0 | 5     | 61            |    |
| 3:45 PM                         | 0                          | 0    | 0     | 0 | 0                          | 0    | 0     | 0 | 0                    | 2    | 0     | 0 | 0                    | 3    | 0     | 0 | 5     | 60            |    |
| 3:50 PM                         | 0                          | 0    | 1     | 0 | 0                          | 1    | 1     | 0 | 1                    | 2    | 0     | 0 | 0                    | 1    | 0     | 0 | 7     | 64            |    |
| 3:55 PM                         | 0                          | 0    | 0     | 0 | 0                          | 0    | 0     | 0 | 0                    | 2    | 0     | 0 | 0                    | 1    | 0     | 0 | 3     | 62            |    |
| 4:00 PM                         | 0                          | 0    | 0     | 0 | 0                          | 0    | 0     | 0 | 0                    | 5    | 0     | 0 | 0                    | 1    | 1     | 0 | 7     | 61            |    |
| 4:05 PM                         | 2                          | 1    | 0     | 0 | 0                          | 0    | 0     | 0 | 0                    | 3    | 0     | 0 | 0                    | 1    | 2     | 0 | 9     | 66            |    |
| 4:10 PM                         | 0                          | 0    | 0     | 0 | 0                          | 2    | 0     | 0 | 1                    | 2    | 1     | 0 | 1                    | 0    | 3     | 0 | 10    | 69            |    |
| 4:15 PM                         | 0                          | 1    | 0     | 0 | 0                          | 0    | 0     | 0 | 0                    | 3    | 0     | 0 | 0                    | 0    | 0     | 0 | 4     | 67            |    |
| 4:20 PM                         | 0                          | 0    | 0     | 0 | 1                          | 0    | 0     | 0 | 3                    | 1    | 0     | 0 | 0                    | 2    | 0     | 0 | 7     | 71            |    |
| 4:25 PM                         | 0                          | 0    | 0     | 0 | 0                          | 1    | 0     | 0 | 0                    | 4    | 0     | 0 | 0                    | 2    | 0     | 0 | 7     | 73            |    |
| 4:30 PM                         | 0                          | 0    | 0     | 0 | 1                          | 0    | 0     | 0 | 0                    | 1    | 0     | 0 | 1                    | 4    | 0     | 0 | 7     | 76            |    |

## Attachment B

| 5-Min Count Period Beginning At | Silver Fox Rd (Northbound) |      |       |   | Silver Fox Rd (Southbound) |      |       |   | Druid Ln (Eastbound) |      |       |   | Druid Ln (Westbound) |      |       |   | Total | Hourly Totals |
|---------------------------------|----------------------------|------|-------|---|----------------------------|------|-------|---|----------------------|------|-------|---|----------------------|------|-------|---|-------|---------------|
|                                 | Left                       | Thru | Right | U | Left                       | Thru | Right | U | Left                 | Thru | Right | U | Left                 | Thru | Right | U |       |               |
| 4:35 PM                         | 0                          | 0    | 0     | 0 | 1                          | 0    | 1     | 0 | 0                    | 1    | 0     | 0 | 0                    | 4    | 0     | 0 | 7     | 78            |
| 4:40 PM                         | 0                          | 0    | 0     | 0 | 0                          | 0    | 1     | 0 | 0                    | 1    | 0     | 0 | 0                    | 2    | 0     | 0 | 4     | 77            |
| 4:45 PM                         | 0                          | 0    | 0     | 0 | 1                          | 0    | 1     | 0 | 0                    | 3    | 0     | 0 | 0                    | 3    | 0     | 0 | 8     | 80            |
| 4:50 PM                         | 0                          | 0    | 0     | 0 | 0                          | 0    | 0     | 0 | 0                    | 2    | 0     | 0 | 0                    | 1    | 0     | 0 | 3     | 76            |
| 4:55 PM                         | 0                          | 0    | 0     | 0 | 0                          | 1    | 0     | 0 | 0                    | 2    | 0     | 0 | 0                    | 0    | 0     | 0 | 3     | 76            |
| 5:00 PM                         | 1                          | 0    | 0     | 0 | 0                          | 0    | 0     | 0 | 1                    | 1    | 0     | 0 | 0                    | 0    | 0     | 0 | 3     | 72            |
| 5:05 PM                         | 1                          | 0    | 0     | 0 | 0                          | 1    | 0     | 0 | 0                    | 3    | 0     | 0 | 0                    | 1    | 0     | 0 | 6     | 69            |
| 5:10 PM                         | 0                          | 0    | 0     | 0 | 0                          | 0    | 0     | 0 | 0                    | 2    | 0     | 0 | 0                    | 4    | 0     | 0 | 6     | 65            |
| 5:15 PM                         | 0                          | 0    | 0     | 0 | 0                          | 0    | 0     | 0 | 0                    | 2    | 0     | 0 | 0                    | 1    | 1     | 0 | 4     | 65            |
| 5:20 PM                         | 1                          | 0    | 0     | 0 | 0                          | 0    | 0     | 0 | 0                    | 0    | 0     | 0 | 0                    | 1    | 0     | 0 | 2     | 60            |
| 5:25 PM                         | 0                          | 0    | 0     | 0 | 0                          | 0    | 0     | 0 | 0                    | 2    | 1     | 0 | 0                    | 1    | 0     | 0 | 4     | 57            |
| 5:30 PM                         | 1                          | 1    | 0     | 0 | 1                          | 0    | 0     | 0 | 0                    | 1    | 0     | 0 | 0                    | 3    | 0     | 0 | 7     | 57            |
| 5:35 PM                         | 0                          | 0    | 0     | 0 | 1                          | 0    | 0     | 0 | 0                    | 1    | 0     | 0 | 0                    | 0    | 0     | 0 | 2     | 52            |
| 5:40 PM                         | 0                          | 1    | 0     | 0 | 1                          | 1    | 0     | 0 | 1                    | 2    | 0     | 0 | 0                    | 0    | 2     | 0 | 8     | 56            |
| 5:45 PM                         | 0                          | 0    | 0     | 0 | 0                          | 0    | 0     | 0 | 0                    | 3    | 0     | 0 | 1                    | 1    | 0     | 0 | 5     | 53            |
| 5:50 PM                         | 0                          | 0    | 0     | 0 | 0                          | 0    | 1     | 0 | 0                    | 1    | 0     | 0 | 0                    | 2    | 0     | 0 | 4     | 54            |
| 5:55 PM                         | 0                          | 0    | 0     | 0 | 0                          | 0    | 0     | 0 | 0                    | 1    | 0     | 0 | 0                    | 2    | 0     | 0 | 3     | 54            |
| 6:00 PM                         | 1                          | 0    | 0     | 0 | 0                          | 0    | 0     | 0 | 0                    | 4    | 0     | 0 | 0                    | 2    | 0     | 0 | 7     | 58            |
| 6:05 PM                         | 0                          | 0    | 0     | 0 | 0                          | 0    | 0     | 0 | 0                    | 1    | 0     | 0 | 0                    | 3    | 0     | 0 | 4     | 56            |
| 6:10 PM                         | 0                          | 0    | 0     | 0 | 0                          | 0    | 0     | 0 | 0                    | 0    | 0     | 0 | 0                    | 1    | 0     | 0 | 1     | 51            |
| 6:15 PM                         | 0                          | 1    | 1     | 0 | 0                          | 0    | 1     | 0 | 0                    | 1    | 0     | 0 | 0                    | 3    | 0     | 0 | 7     | 54            |
| 6:20 PM                         | 0                          | 0    | 0     | 0 | 0                          | 0    | 0     | 0 | 0                    | 1    | 0     | 0 | 0                    | 1    | 0     | 0 | 2     | 54            |
| 6:25 PM                         | 0                          | 0    | 0     | 0 | 0                          | 0    | 0     | 0 | 0                    | 0    | 0     | 0 | 0                    | 0    | 0     | 0 | 0     | 50            |
| 6:30 PM                         | 0                          | 0    | 0     | 0 | 0                          | 0    | 0     | 0 | 0                    | 1    | 0     | 0 | 0                    | 4    | 1     | 0 | 6     | 49            |
| 6:35 PM                         | 0                          | 1    | 0     | 0 | 0                          | 0    | 0     | 0 | 0                    | 6    | 0     | 0 | 0                    | 4    | 0     | 0 | 11    | 58            |
| 6:40 PM                         | 0                          | 0    | 0     | 0 | 1                          | 0    | 0     | 0 | 1                    | 4    | 0     | 0 | 0                    | 2    | 0     | 0 | 8     | 58            |
| 6:45 PM                         | 0                          | 1    | 0     | 0 | 0                          | 1    | 0     | 0 | 0                    | 2    | 0     | 0 | 0                    | 0    | 1     | 0 | 5     | 58            |
| 6:50 PM                         | 0                          | 0    | 0     | 0 | 1                          | 0    | 1     | 0 | 0                    | 2    | 0     | 0 | 0                    | 4    | 0     | 0 | 8     | 62            |
| 6:55 PM                         | 0                          | 1    | 0     | 0 | 0                          | 0    | 0     | 0 | 0                    | 1    | 0     | 0 | 0                    | 0    | 0     | 0 | 2     | 61            |
| 7:00 PM                         | 0                          | 0    | 0     | 0 | 0                          | 0    | 0     | 0 | 0                    | 1    | 0     | 0 | 0                    | 1    | 1     | 0 | 3     | 57            |
| 7:05 PM                         | 0                          | 0    | 0     | 0 | 0                          | 0    | 0     | 0 | 0                    | 0    | 0     | 0 | 0                    | 2    | 0     | 0 | 2     | 55            |
| 7:10 PM                         | 0                          | 0    | 0     | 0 | 0                          | 0    | 0     | 0 | 0                    | 4    | 0     | 0 | 0                    | 2    | 1     | 0 | 7     | 61            |
| 7:15 PM                         | 0                          | 0    | 0     | 0 | 0                          | 0    | 0     | 0 | 0                    | 2    | 0     | 0 | 0                    | 4    | 0     | 0 | 6     | 60            |
| 7:20 PM                         | 0                          | 0    | 0     | 0 | 0                          | 0    | 0     | 0 | 0                    | 4    | 0     | 0 | 0                    | 2    | 0     | 0 | 6     | 64            |
| 7:25 PM                         | 0                          | 0    | 0     | 0 | 0                          | 0    | 0     | 0 | 0                    | 0    | 0     | 0 | 0                    | 4    | 0     | 0 | 4     | 68            |
| 7:30 PM                         | 0                          | 0    | 0     | 0 | 0                          | 0    | 0     | 0 | 0                    | 0    | 0     | 0 | 0                    | 2    | 0     | 0 | 2     | 64            |
| 7:35 PM                         | 1                          | 0    | 0     | 0 | 0                          | 0    | 0     | 0 | 0                    | 2    | 0     | 0 | 0                    | 0    | 0     | 0 | 3     | 56            |
| 7:40 PM                         | 0                          | 0    | 0     | 0 | 0                          | 0    | 0     | 0 | 0                    | 2    | 0     | 0 | 0                    | 0    | 0     | 0 | 2     | 50            |
| 7:45 PM                         | 0                          | 0    | 0     | 0 | 0                          | 1    | 1     | 0 | 0                    | 1    | 0     | 0 | 1                    | 5    | 0     | 0 | 9     | 54            |
| 7:50 PM                         | 0                          | 0    | 0     | 0 | 0                          | 0    | 0     | 0 | 1                    | 0    | 0     | 0 | 0                    | 0    | 0     | 0 | 1     | 47            |
| 7:55 PM                         | 1                          | 1    | 0     | 0 | 0                          | 0    | 0     | 0 | 0                    | 0    | 0     | 0 | 1                    | 2    | 0     | 0 | 5     | 50            |
| 8:00 PM                         | 0                          | 0    | 0     | 0 | 0                          | 0    | 0     | 0 | 0                    | 0    | 0     | 0 | 0                    | 1    | 0     | 0 | 1     | 48            |
| 8:05 PM                         | 0                          | 0    | 0     | 0 | 0                          | 0    | 0     | 0 | 0                    | 1    | 0     | 0 | 0                    | 6    | 0     | 0 | 7     | 53            |
| 8:10 PM                         | 0                          | 0    | 0     | 0 | 0                          | 0    | 0     | 0 | 1                    | 0    | 0     | 0 | 0                    | 0    | 0     | 0 | 1     | 47            |
| 8:15 PM                         | 0                          | 0    | 0     | 0 | 1                          | 0    | 0     | 0 | 0                    | 0    | 0     | 0 | 0                    | 1    | 0     | 0 | 2     | 43            |
| 8:20 PM                         | 0                          | 0    | 0     | 0 | 0                          | 0    | 0     | 0 | 0                    | 1    | 0     | 0 | 0                    | 3    | 0     | 0 | 4     | 41            |
| 8:25 PM                         | 1                          | 1    | 0     | 0 | 1                          | 0    | 0     | 0 | 0                    | 0    | 0     | 0 | 0                    | 2    | 0     | 0 | 5     | 42            |
| 8:30 PM                         | 0                          | 0    | 0     | 0 | 0                          | 0    | 0     | 0 | 0                    | 0    | 0     | 0 | 0                    | 1    | 0     | 0 | 1     | 41            |
| 8:35 PM                         | 0                          | 1    | 0     | 0 | 0                          | 0    | 0     | 0 | 0                    | 0    | 0     | 0 | 1                    | 0    | 0     | 0 | 2     | 40            |
| 8:40 PM                         | 0                          | 0    | 0     | 0 | 2                          | 0    | 0     | 0 | 0                    | 0    | 0     | 0 | 0                    | 0    | 0     | 0 | 2     | 40            |
| 8:45 PM                         | 1                          | 0    | 0     | 0 | 0                          | 0    | 0     | 0 | 0                    | 1    | 0     | 0 | 0                    | 1    | 0     | 0 | 3     | 34            |
| 8:50 PM                         | 0                          | 0    | 0     | 0 | 0                          | 0    | 0     | 0 | 0                    | 0    | 0     | 0 | 0                    | 2    | 0     | 0 | 2     | 35            |
| 8:55 PM                         | 0                          | 1    | 0     | 0 | 0                          | 1    | 0     | 0 | 0                    | 0    | 0     | 0 | 0                    | 0    | 0     | 0 | 2     | 32            |
| 9:00 PM                         | 0                          | 0    | 0     | 0 | 0                          | 0    | 0     | 0 | 0                    | 1    | 0     | 0 | 0                    | 0    | 0     | 0 | 1     | 32            |
| 9:05 PM                         | 0                          | 0    | 0     | 0 | 2                          | 0    | 0     | 0 | 1                    | 2    | 0     | 0 | 0                    | 1    | 0     | 0 | 6     | 31            |
| 9:10 PM                         | 0                          | 0    | 0     | 0 | 0                          | 0    | 0     | 0 | 0                    | 0    | 0     | 0 | 0                    | 1    | 0     | 0 | 1     | 31            |
| 9:15 PM                         | 0                          | 0    | 0     | 0 | 1                          | 0    | 0     | 0 | 0                    | 0    | 0     | 0 | 0                    | 0    | 0     | 0 | 1     | 30            |
| 9:20 PM                         | 0                          | 0    | 0     | 0 | 0                          | 0    | 0     | 0 | 0                    | 0    | 0     | 0 | 0                    | 1    | 0     | 0 | 1     | 27            |
| 9:25 PM                         | 0                          | 0    | 0     | 0 | 0                          | 0    | 0     | 0 | 0                    | 0    | 0     | 0 | 0                    | 2    | 1     | 0 | 3     | 25            |
| 9:30 PM                         | 0                          | 0    | 0     | 0 | 0                          | 0    | 0     | 0 | 0                    | 0    | 0     | 0 | 0                    | 0    | 0     | 0 | 0     | 24            |
| 9:35 PM                         | 0                          | 0    | 0     | 0 | 0                          | 0    | 1     | 0 | 0                    | 1    | 0     | 0 | 0                    | 0    | 0     | 0 | 2     | 24            |
| 9:40 PM                         | 0                          | 0    | 1     | 0 | 1                          | 0    | 0     | 0 | 0                    | 0    | 0     | 0 | 0                    | 0    | 0     | 0 | 2     | 24            |
| 9:45 PM                         | 0                          | 0    | 0     | 0 | 0                          | 0    | 0     | 0 | 0                    | 1    | 0     | 0 | 0                    | 0    | 0     | 0 | 1     | 22            |
| 9:50 PM                         | 0                          | 0    | 0     | 0 | 0                          | 0    | 0     | 0 | 0                    | 1    | 1     | 0 | 0                    | 1    | 0     | 0 | 3     | 23            |
| 9:55 PM                         | 0                          | 0    | 0     | 0 | 0                          | 0    | 0     | 0 | 0                    | 0    | 0     | 0 | 0                    | 0    | 0     | 0 | 0     | 21            |
| Peak 15-Min Flowrates           | Northbound                 |      |       |   | Southbound                 |      |       |   | Eastbound            |      |       |   | Westbound            |      |       |   | Total |               |
|                                 | Left                       | Thru | Right | U | Left                       | Thru | Right | U | Left                 | Thru | Right | U | Left                 | Thru | Right | U |       |               |
| All Vehicles                    | 16                         | 4    | 0     | 0 | 4                          | 0    | 4     | 0 | 4                    | 60   | 4     | 0 | 0                    | 40   | 8     | 0 | 144   |               |
| Heavy Trucks                    | 0                          | 0    | 0     | 0 | 0                          | 0    | 0     | 0 | 0                    | 8    | 0     | 0 | 0                    | 0    | 0     | 0 | 8     |               |
| Buses                           |                            |      |       |   |                            |      |       |   |                      |      |       |   |                      |      |       |   |       |               |
| Pedestrians                     |                            | 0    |       |   |                            | 0    |       |   |                      | 0    |       |   |                      | 0    |       |   | 0     |               |
| Bicycles                        | 0                          | 0    | 0     |   | 0                          | 0    | 0     |   | 0                    | 0    | 0     |   | 0                    | 0    | 0     |   | 0     |               |
| Scoters                         |                            |      |       |   |                            |      |       |   |                      |      |       |   |                      |      |       |   |       |               |
| <i>Comments:</i>                |                            |      |       |   |                            |      |       |   |                      |      |       |   |                      |      |       |   |       |               |

Report generated on 4/25/2025 4:02 PM

SOURCE: Quality Counts, LLC (<http://www.qualitycounts.net>) 1-877-580-2212

LOCATION: Bellwood Rd -- Walker Lee Dr  
 CITY/STATE: Rossmore, CA

QC JOB #: 16966414  
 DATE: Wed, Apr 9 2025

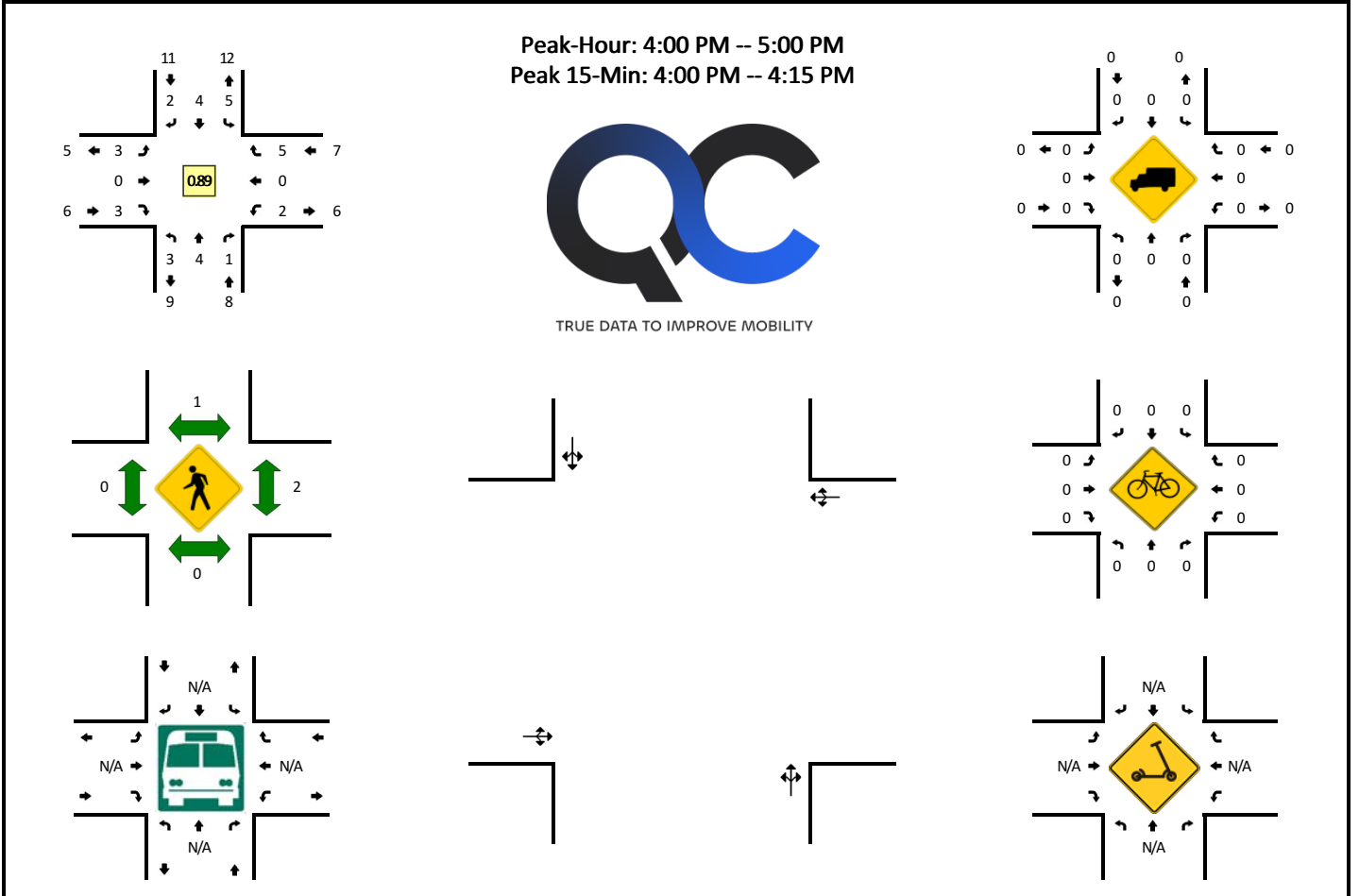

| 5-Min Count Period Beginning At | Bellwood Rd (Northbound) |      |       |   | Bellwood Rd (Southbound) |      |       |   | Walker Lee Dr (Eastbound) |      |       |   | Walker Lee Dr (Westbound) |      |       |   | Total | Hourly Totals |    |
|---------------------------------|--------------------------|------|-------|---|--------------------------|------|-------|---|---------------------------|------|-------|---|---------------------------|------|-------|---|-------|---------------|----|
|                                 | Left                     | Thru | Right | U | Left                     | Thru | Right | U | Left                      | Thru | Right | U | Left                      | Thru | Right | U |       |               |    |
| 6:00 AM                         | 0                        | 0    | 0     | 0 | 0                        | 0    | 0     | 0 | 0                         | 0    | 0     | 1 | 0                         | 0    | 0     | 0 | 0     | 1             |    |
| 6:05 AM                         | 0                        | 0    | 0     | 0 | 0                        | 0    | 0     | 0 | 0                         | 0    | 0     | 0 | 0                         | 0    | 0     | 0 | 0     | 0             |    |
| 6:10 AM                         | 0                        | 0    | 0     | 0 | 0                        | 0    | 0     | 0 | 0                         | 1    | 0     | 0 | 0                         | 0    | 0     | 0 | 0     | 1             |    |
| 6:15 AM                         | 0                        | 0    | 0     | 0 | 0                        | 1    | 0     | 0 | 0                         | 0    | 0     | 0 | 0                         | 0    | 0     | 0 | 0     | 1             |    |
| 6:20 AM                         | 0                        | 0    | 0     | 0 | 0                        | 0    | 0     | 0 | 0                         | 0    | 0     | 0 | 0                         | 0    | 0     | 0 | 0     | 0             |    |
| 6:25 AM                         | 0                        | 1    | 0     | 0 | 0                        | 0    | 0     | 0 | 0                         | 0    | 0     | 0 | 0                         | 0    | 0     | 0 | 0     | 1             |    |
| 6:30 AM                         | 0                        | 0    | 0     | 0 | 0                        | 0    | 0     | 0 | 0                         | 0    | 0     | 0 | 0                         | 0    | 0     | 0 | 0     | 0             |    |
| 6:35 AM                         | 0                        | 0    | 0     | 0 | 0                        | 0    | 0     | 0 | 0                         | 0    | 0     | 1 | 0                         | 0    | 0     | 0 | 0     | 1             |    |
| 6:40 AM                         | 0                        | 0    | 0     | 0 | 0                        | 0    | 0     | 0 | 0                         | 0    | 0     | 0 | 0                         | 0    | 0     | 0 | 0     | 0             |    |
| 6:45 AM                         | 0                        | 0    | 0     | 0 | 0                        | 0    | 0     | 0 | 0                         | 0    | 0     | 1 | 0                         | 0    | 0     | 0 | 0     | 1             |    |
| 6:50 AM                         | 0                        | 0    | 1     | 0 | 0                        | 0    | 0     | 0 | 0                         | 0    | 0     | 0 | 0                         | 0    | 0     | 0 | 0     | 1             |    |
| 6:55 AM                         | 0                        | 0    | 0     | 0 | 1                        | 0    | 0     | 0 | 0                         | 0    | 0     | 0 | 0                         | 0    | 0     | 0 | 0     | 1             | 8  |
| 7:00 AM                         | 0                        | 1    | 0     | 0 | 1                        | 0    | 0     | 0 | 0                         | 0    | 0     | 0 | 0                         | 0    | 0     | 0 | 0     | 2             | 9  |
| 7:05 AM                         | 0                        | 0    | 0     | 0 | 0                        | 0    | 0     | 0 | 0                         | 0    | 0     | 0 | 0                         | 1    | 0     | 0 | 1     | 10            | 10 |
| 7:10 AM                         | 0                        | 0    | 0     | 0 | 0                        | 0    | 0     | 0 | 0                         | 0    | 0     | 0 | 1                         | 0    | 0     | 0 | 1     | 10            | 10 |
| 7:15 AM                         | 0                        | 1    | 0     | 0 | 0                        | 0    | 0     | 0 | 0                         | 0    | 0     | 1 | 0                         | 0    | 0     | 0 | 2     | 11            | 11 |
| 7:20 AM                         | 0                        | 0    | 0     | 0 | 0                        | 0    | 0     | 0 | 0                         | 0    | 0     | 0 | 0                         | 0    | 0     | 0 | 0     | 0             |    |
| 7:25 AM                         | 0                        | 1    | 0     | 0 | 1                        | 0    | 1     | 0 | 0                         | 0    | 0     | 0 | 0                         | 0    | 1     | 0 | 3     | 13            | 13 |
| 7:30 AM                         | 1                        | 0    | 0     | 0 | 0                        | 0    | 0     | 0 | 0                         | 0    | 0     | 1 | 0                         | 0    | 1     | 0 | 3     | 16            | 16 |
| 7:35 AM                         | 0                        | 0    | 0     | 0 | 0                        | 0    | 0     | 0 | 0                         | 0    | 0     | 0 | 0                         | 0    | 0     | 0 | 0     | 15            | 15 |
| 7:40 AM                         | 0                        | 1    | 0     | 0 | 0                        | 0    | 0     | 0 | 0                         | 0    | 0     | 0 | 0                         | 1    | 0     | 0 | 2     | 17            | 17 |
| 7:45 AM                         | 0                        | 1    | 0     | 0 | 0                        | 0    | 0     | 0 | 0                         | 1    | 0     | 0 | 0                         | 0    | 0     | 0 | 2     | 18            | 18 |
| 7:50 AM                         | 0                        | 0    | 0     | 0 | 1                        | 0    | 0     | 0 | 0                         | 0    | 0     | 1 | 0                         | 0    | 0     | 0 | 2     | 19            | 19 |
| 7:55 AM                         | 0                        | 0    | 0     | 0 | 0                        | 0    | 0     | 0 | 0                         | 0    | 0     | 1 | 0                         | 0    | 1     | 0 | 2     | 20            | 20 |
| 8:00 AM                         | 0                        | 0    | 0     | 0 | 0                        | 0    | 0     | 0 | 0                         | 0    | 0     | 0 | 0                         | 1    | 0     | 0 | 1     | 19            | 19 |
| 8:05 AM                         | 0                        | 0    | 1     | 0 | 0                        | 1    | 0     | 0 | 0                         | 0    | 0     | 0 | 0                         | 2    | 0     | 0 | 4     | 22            | 22 |
| 8:10 AM                         | 1                        | 1    | 0     | 0 | 0                        | 0    | 0     | 0 | 0                         | 0    | 0     | 0 | 0                         | 0    | 0     | 0 | 2     | 23            | 23 |
| 8:15 AM                         | 0                        | 0    | 0     | 0 | 0                        | 0    | 0     | 0 | 0                         | 0    | 0     | 1 | 0                         | 0    | 1     | 0 | 2     | 23            | 23 |
| 8:20 AM                         | 0                        | 0    | 0     | 0 | 0                        | 0    | 0     | 0 | 0                         | 0    | 0     | 2 | 0                         | 0    | 0     | 0 | 2     | 25            | 25 |
| 8:25 AM                         | 1                        | 0    | 0     | 0 | 0                        | 1    | 0     | 0 | 0                         | 0    | 0     | 0 | 0                         | 1    | 0     | 0 | 3     | 25            | 25 |
| 8:30 AM                         | 0                        | 2    | 0     | 0 | 0                        | 0    | 0     | 0 | 0                         | 0    | 0     | 0 | 0                         | 0    | 0     | 0 | 2     | 24            | 24 |
| 8:35 AM                         | 1                        | 0    | 0     | 0 | 1                        | 0    | 0     | 0 | 0                         | 0    | 0     | 1 | 0                         | 0    | 0     | 0 | 3     | 27            | 27 |
| 8:40 AM                         | 0                        | 0    | 0     | 0 | 1                        | 0    | 0     | 0 | 0                         | 0    | 0     | 0 | 0                         | 0    | 0     | 0 | 1     | 26            | 26 |
| 8:45 AM                         | 0                        | 0    | 0     | 0 | 0                        | 0    | 0     | 0 | 0                         | 0    | 0     | 0 | 0                         | 0    | 0     | 0 | 0     | 24            | 24 |
| 8:50 AM                         | 0                        | 0    | 0     | 0 | 0                        | 0    | 0     | 0 | 0                         | 0    | 0     | 0 | 0                         | 0    | 0     | 0 | 0     | 22            | 22 |
| 8:55 AM                         | 0                        | 0    | 0     | 0 | 0                        | 0    | 0     | 0 | 0                         | 0    | 0     | 0 | 0                         | 0    | 0     | 0 | 0     | 20            | 20 |
| 9:00 AM                         | 0                        | 0    | 0     | 0 | 0                        | 0    | 0     | 0 | 0                         | 0    | 0     | 0 | 0                         | 0    | 0     | 0 | 0     | 19            | 19 |
| 9:05 AM                         | 0                        | 0    | 0     | 0 | 0                        | 1    | 0     | 0 | 0                         | 0    | 0     | 0 | 0                         | 0    | 0     | 0 | 1     | 16            | 16 |

Attachment B

Table with columns: 5-Min Count Period Beginning At, Bellwood Rd (Northbound), Bellwood Rd (Southbound), Walker Lee Dr (Eastbound), Walker Lee Dr (Westbound), Total, Hourly Totals. Rows list time intervals from 9:10 AM to 4:25 PM.

**Attachment B**

| 5-Min Count Period Beginning At | Bellwood Rd (Northbound) |      |       |   | Bellwood Rd (Southbound) |      |       |   | Walker Lee Dr (Eastbound) |      |       |   | Walker Lee Dr (Westbound) |      |       |   | Total | Hourly Totals |
|---------------------------------|--------------------------|------|-------|---|--------------------------|------|-------|---|---------------------------|------|-------|---|---------------------------|------|-------|---|-------|---------------|
|                                 | Left                     | Thru | Right | U | Left                     | Thru | Right | U | Left                      | Thru | Right | U | Left                      | Thru | Right | U |       |               |
| 4:30 PM                         | 1                        | 0    | 0     | 0 | 0                        | 0    | 0     | 0 | 1                         | 0    | 0     | 0 | 0                         | 0    | 0     | 0 | 2     | 26            |
| 4:35 PM                         | 0                        | 0    | 0     | 0 | 1                        | 1    | 0     | 0 | 0                         | 0    | 0     | 0 | 0                         | 0    | 0     | 0 | 2     | 26            |
| 4:40 PM                         | 1                        | 0    | 0     | 0 | 0                        | 0    | 1     | 0 | 0                         | 0    | 0     | 0 | 0                         | 1    | 0     | 0 | 3     | 29            |
| 4:45 PM                         | 0                        | 1    | 0     | 0 | 0                        | 0    | 1     | 0 | 0                         | 0    | 0     | 0 | 0                         | 0    | 0     | 0 | 2     | 30            |
| 4:50 PM                         | 1                        | 0    | 0     | 0 | 0                        | 0    | 0     | 0 | 0                         | 0    | 0     | 0 | 0                         | 0    | 1     | 0 | 2     | 31            |
| 4:55 PM                         | 0                        | 1    | 0     | 0 | 0                        | 1    | 0     | 0 | 0                         | 0    | 1     | 0 | 0                         | 0    | 0     | 0 | 3     | 32            |
| 5:00 PM                         | 0                        | 0    | 0     | 0 | 0                        | 0    | 0     | 0 | 0                         | 0    | 0     | 0 | 0                         | 0    | 0     | 0 | 0     | 30            |
| 5:05 PM                         | 0                        | 0    | 0     | 0 | 0                        | 0    | 1     | 0 | 0                         | 0    | 0     | 0 | 0                         | 0    | 1     | 0 | 2     | 27            |
| 5:10 PM                         | 1                        | 0    | 0     | 0 | 0                        | 1    | 0     | 0 | 0                         | 0    | 0     | 0 | 0                         | 0    | 0     | 0 | 2     | 27            |
| 5:15 PM                         | 0                        | 0    | 0     | 0 | 0                        | 0    | 0     | 0 | 0                         | 0    | 0     | 0 | 0                         | 0    | 0     | 0 | 0     | 25            |
| 5:20 PM                         | 0                        | 0    | 0     | 0 | 1                        | 0    | 0     | 0 | 0                         | 0    | 0     | 0 | 1                         | 0    | 0     | 0 | 2     | 23            |
| 5:25 PM                         | 0                        | 2    | 0     | 0 | 0                        | 0    | 0     | 0 | 0                         | 0    | 0     | 0 | 1                         | 0    | 0     | 0 | 3     | 23            |
| 5:30 PM                         | 0                        | 0    | 0     | 0 | 0                        | 1    | 1     | 0 | 0                         | 0    | 0     | 0 | 0                         | 0    | 0     | 0 | 2     | 23            |
| 5:35 PM                         | 0                        | 2    | 0     | 0 | 1                        | 1    | 0     | 0 | 0                         | 0    | 0     | 0 | 0                         | 0    | 1     | 0 | 5     | 26            |
| 5:40 PM                         | 1                        | 1    | 0     | 0 | 1                        | 0    | 1     | 0 | 1                         | 0    | 0     | 0 | 0                         | 0    | 0     | 0 | 5     | 28            |
| 5:45 PM                         | 0                        | 0    | 0     | 0 | 0                        | 0    | 0     | 0 | 0                         | 0    | 0     | 0 | 0                         | 0    | 0     | 0 | 0     | 26            |
| 5:50 PM                         | 0                        | 0    | 1     | 0 | 0                        | 0    | 0     | 0 | 0                         | 0    | 0     | 0 | 0                         | 0    | 0     | 0 | 1     | 25            |
| 5:55 PM                         | 0                        | 1    | 0     | 0 | 0                        | 1    | 0     | 0 | 0                         | 0    | 1     | 0 | 0                         | 0    | 0     | 0 | 3     | 25            |
| 6:00 PM                         | 0                        | 0    | 0     | 0 | 1                        | 0    | 0     | 0 | 0                         | 0    | 0     | 0 | 0                         | 0    | 0     | 0 | 1     | 26            |
| 6:05 PM                         | 0                        | 0    | 0     | 0 | 0                        | 0    | 0     | 0 | 0                         | 0    | 0     | 0 | 0                         | 0    | 0     | 0 | 0     | 24            |
| 6:10 PM                         | 0                        | 0    | 0     | 0 | 0                        | 0    | 0     | 0 | 0                         | 0    | 0     | 0 | 0                         | 0    | 0     | 0 | 0     | 22            |
| 6:15 PM                         | 0                        | 0    | 0     | 0 | 0                        | 0    | 1     | 0 | 0                         | 0    | 0     | 0 | 0                         | 0    | 0     | 0 | 1     | 23            |
| 6:20 PM                         | 0                        | 0    | 0     | 0 | 0                        | 0    | 0     | 0 | 0                         | 1    | 0     | 0 | 0                         | 0    | 0     | 0 | 1     | 22            |
| 6:25 PM                         | 0                        | 0    | 0     | 0 | 1                        | 0    | 0     | 0 | 0                         | 0    | 0     | 0 | 0                         | 1    | 0     | 0 | 2     | 21            |
| 6:30 PM                         | 0                        | 0    | 0     | 0 | 1                        | 0    | 0     | 0 | 0                         | 0    | 0     | 0 | 0                         | 0    | 0     | 0 | 1     | 20            |
| 6:35 PM                         | 1                        | 0    | 0     | 0 | 0                        | 0    | 0     | 0 | 0                         | 0    | 0     | 0 | 0                         | 0    | 1     | 0 | 2     | 17            |
| 6:40 PM                         | 0                        | 1    | 0     | 0 | 0                        | 0    | 0     | 0 | 0                         | 0    | 0     | 0 | 0                         | 0    | 1     | 0 | 2     | 14            |
| 6:45 PM                         | 1                        | 0    | 0     | 0 | 0                        | 0    | 0     | 0 | 0                         | 0    | 0     | 0 | 0                         | 0    | 0     | 0 | 1     | 15            |
| 6:50 PM                         | 2                        | 0    | 0     | 0 | 0                        | 0    | 0     | 0 | 0                         | 0    | 0     | 0 | 2                         | 0    | 0     | 0 | 4     | 18            |
| 6:55 PM                         | 0                        | 0    | 0     | 0 | 0                        | 1    | 0     | 0 | 0                         | 0    | 0     | 0 | 0                         | 0    | 1     | 0 | 2     | 17            |
| 7:00 PM                         | 0                        | 0    | 1     | 0 | 0                        | 0    | 0     | 0 | 0                         | 0    | 0     | 0 | 0                         | 0    | 0     | 0 | 1     | 17            |
| 7:05 PM                         | 0                        | 0    | 1     | 0 | 0                        | 0    | 0     | 0 | 0                         | 0    | 0     | 0 | 0                         | 0    | 0     | 0 | 1     | 18            |
| 7:10 PM                         | 0                        | 0    | 0     | 0 | 0                        | 0    | 0     | 0 | 0                         | 0    | 0     | 0 | 0                         | 0    | 0     | 0 | 0     | 18            |
| 7:15 PM                         | 0                        | 0    | 0     | 0 | 0                        | 0    | 0     | 0 | 0                         | 0    | 0     | 0 | 0                         | 0    | 0     | 0 | 0     | 17            |
| 7:20 PM                         | 0                        | 1    | 0     | 0 | 1                        | 0    | 1     | 0 | 0                         | 0    | 0     | 0 | 0                         | 0    | 1     | 0 | 4     | 20            |
| 7:25 PM                         | 0                        | 0    | 0     | 0 | 0                        | 0    | 0     | 0 | 0                         | 0    | 0     | 0 | 0                         | 0    | 0     | 0 | 0     | 18            |
| 7:30 PM                         | 0                        | 0    | 0     | 0 | 0                        | 1    | 1     | 0 | 1                         | 0    | 0     | 0 | 0                         | 0    | 0     | 0 | 3     | 20            |
| 7:35 PM                         | 0                        | 0    | 0     | 0 | 0                        | 1    | 0     | 0 | 0                         | 0    | 1     | 0 | 0                         | 0    | 0     | 0 | 2     | 20            |
| 7:40 PM                         | 0                        | 0    | 0     | 0 | 0                        | 1    | 0     | 0 | 0                         | 0    | 0     | 0 | 0                         | 0    | 0     | 0 | 1     | 19            |
| 7:45 PM                         | 1                        | 0    | 0     | 0 | 1                        | 2    | 0     | 0 | 0                         | 0    | 0     | 0 | 0                         | 0    | 0     | 0 | 4     | 22            |
| 7:50 PM                         | 0                        | 1    | 0     | 0 | 0                        | 0    | 0     | 0 | 0                         | 0    | 0     | 0 | 0                         | 0    | 0     | 0 | 1     | 19            |
| 7:55 PM                         | 0                        | 0    | 0     | 0 | 0                        | 0    | 0     | 0 | 0                         | 0    | 0     | 0 | 0                         | 0    | 0     | 0 | 0     | 17            |
| 8:00 PM                         | 0                        | 1    | 0     | 0 | 0                        | 0    | 0     | 0 | 1                         | 0    | 0     | 0 | 0                         | 0    | 0     | 0 | 2     | 18            |
| 8:05 PM                         | 0                        | 1    | 0     | 0 | 0                        | 0    | 0     | 0 | 0                         | 0    | 0     | 0 | 0                         | 0    | 0     | 0 | 1     | 18            |
| 8:10 PM                         | 0                        | 0    | 1     | 0 | 0                        | 0    | 0     | 0 | 0                         | 0    | 0     | 0 | 0                         | 0    | 0     | 0 | 1     | 19            |
| 8:15 PM                         | 0                        | 0    | 0     | 0 | 0                        | 0    | 0     | 0 | 0                         | 0    | 1     | 0 | 0                         | 0    | 0     | 0 | 1     | 20            |
| 8:20 PM                         | 0                        | 1    | 0     | 0 | 0                        | 0    | 0     | 0 | 0                         | 0    | 0     | 0 | 0                         | 0    | 0     | 0 | 1     | 17            |
| 8:25 PM                         | 0                        | 0    | 0     | 0 | 0                        | 0    | 0     | 0 | 0                         | 0    | 0     | 0 | 0                         | 0    | 0     | 0 | 0     | 17            |
| 8:30 PM                         | 0                        | 0    | 0     | 0 | 0                        | 0    | 0     | 0 | 0                         | 0    | 0     | 0 | 0                         | 0    | 0     | 0 | 0     | 14            |
| 8:35 PM                         | 0                        | 0    | 0     | 0 | 0                        | 0    | 0     | 0 | 0                         | 0    | 0     | 0 | 0                         | 0    | 0     | 0 | 0     | 12            |
| 8:40 PM                         | 0                        | 0    | 0     | 0 | 0                        | 0    | 0     | 0 | 0                         | 0    | 0     | 0 | 0                         | 0    | 0     | 0 | 0     | 11            |
| 8:45 PM                         | 0                        | 1    | 0     | 0 | 0                        | 0    | 0     | 0 | 0                         | 0    | 0     | 0 | 0                         | 0    | 0     | 0 | 1     | 8             |
| 8:50 PM                         | 1                        | 0    | 0     | 0 | 0                        | 0    | 0     | 0 | 0                         | 0    | 0     | 0 | 0                         | 0    | 0     | 0 | 1     | 8             |
| 8:55 PM                         | 0                        | 0    | 0     | 0 | 0                        | 0    | 0     | 0 | 0                         | 0    | 0     | 0 | 0                         | 0    | 0     | 0 | 0     | 8             |
| 9:00 PM                         | 0                        | 0    | 0     | 0 | 0                        | 1    | 0     | 0 | 0                         | 0    | 0     | 0 | 0                         | 0    | 0     | 0 | 1     | 7             |
| 9:05 PM                         | 0                        | 0    | 0     | 0 | 0                        | 1    | 0     | 0 | 0                         | 0    | 0     | 0 | 0                         | 0    | 0     | 0 | 1     | 7             |
| 9:10 PM                         | 0                        | 0    | 0     | 0 | 0                        | 0    | 0     | 0 | 0                         | 0    | 0     | 0 | 0                         | 0    | 0     | 0 | 0     | 6             |
| 9:15 PM                         | 0                        | 0    | 0     | 0 | 0                        | 0    | 0     | 0 | 0                         | 0    | 0     | 0 | 0                         | 0    | 0     | 0 | 0     | 5             |
| 9:20 PM                         | 0                        | 0    | 0     | 0 | 0                        | 0    | 0     | 0 | 0                         | 0    | 0     | 0 | 0                         | 0    | 0     | 0 | 0     | 4             |
| 9:25 PM                         | 0                        | 0    | 1     | 0 | 0                        | 0    | 0     | 0 | 0                         | 0    | 0     | 0 | 0                         | 1    | 0     | 0 | 2     | 6             |
| 9:30 PM                         | 0                        | 0    | 0     | 0 | 0                        | 0    | 0     | 0 | 0                         | 0    | 0     | 0 | 0                         | 0    | 0     | 0 | 0     | 6             |
| 9:35 PM                         | 0                        | 0    | 0     | 0 | 0                        | 0    | 0     | 0 | 0                         | 0    | 0     | 0 | 0                         | 0    | 0     | 0 | 0     | 6             |
| 9:40 PM                         | 0                        | 0    | 0     | 0 | 0                        | 0    | 0     | 0 | 0                         | 0    | 0     | 0 | 0                         | 1    | 0     | 0 | 1     | 7             |
| 9:45 PM                         | 0                        | 1    | 0     | 0 | 0                        | 1    | 0     | 0 | 0                         | 0    | 0     | 0 | 0                         | 0    | 0     | 0 | 2     | 8             |
| 9:50 PM                         | 0                        | 0    | 0     | 0 | 0                        | 0    | 0     | 0 | 0                         | 0    | 0     | 0 | 0                         | 0    | 0     | 0 | 0     | 7             |
| 9:55 PM                         | 0                        | 0    | 0     | 0 | 0                        | 0    | 0     | 0 | 0                         | 0    | 0     | 0 | 0                         | 0    | 0     | 0 | 0     | 7             |
| Peak 15-Min Flowrates           | Northbound               |      |       |   | Southbound               |      |       |   | Eastbound                 |      |       |   | Westbound                 |      |       |   | Total |               |
|                                 | Left                     | Thru | Right | U | Left                     | Thru | Right | U | Left                      | Thru | Right | U | Left                      | Thru | Right | U |       |               |
| All Vehicles                    | 0                        | 4    | 4     | 0 | 12                       | 0    | 0     | 0 | 4                         | 0    | 4     | 0 | 4                         | 0    | 4     | 0 | 36    |               |
| Heavy Trucks                    | 0                        | 0    | 0     | 0 | 0                        | 0    | 0     | 0 | 0                         | 0    | 0     | 0 | 0                         | 0    | 0     | 0 | 0     |               |
| Buses                           |                          |      |       |   |                          |      |       |   |                           |      |       |   |                           |      |       |   |       |               |
| Pedestrians                     |                          | 0    |       |   |                          | 0    |       |   |                           | 0    |       |   |                           | 8    |       |   | 8     |               |
| Bicycles                        | 0                        | 0    | 0     |   | 0                        | 0    | 0     |   | 0                         | 0    | 0     |   | 0                         | 0    | 0     |   | 0     |               |
| Scoters                         |                          |      |       |   |                          |      |       |   |                           |      |       |   |                           |      |       |   |       |               |
| <i>Comments:</i>                |                          |      |       |   |                          |      |       |   |                           |      |       |   |                           |      |       |   |       |               |

LOCATION: Silver Fox Rd -- St Albans Dr  
 CITY/STATE: Rossmore, CA

QC JOB #: 16966415  
 DATE: Wed, Apr 9 2025

Peak-Hour: 7:30 AM -- 8:30 AM  
 Peak 15-Min: 7:55 AM -- 8:10 AM

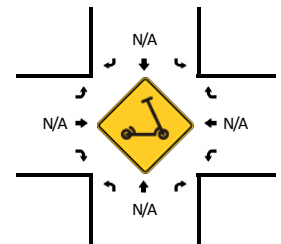
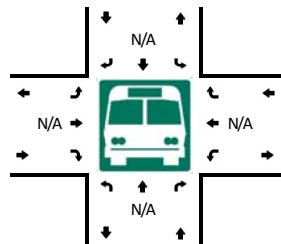
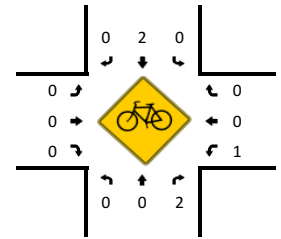
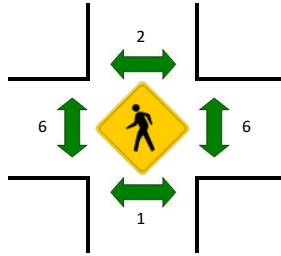
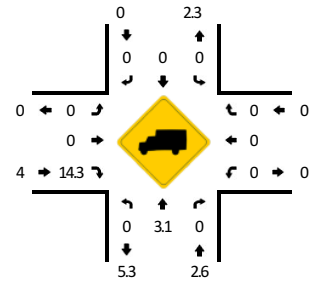
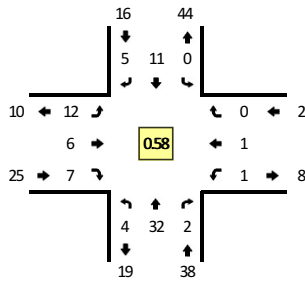

| 5-Min Count Period Beginning At | Silver Fox Rd (Northbound) |      |       |   | Silver Fox Rd (Southbound) |      |       |   | St Albans Dr (Eastbound) |      |       |   | St Albans Dr (Westbound) |      |       |   | Total | Hourly Totals |
|---------------------------------|----------------------------|------|-------|---|----------------------------|------|-------|---|--------------------------|------|-------|---|--------------------------|------|-------|---|-------|---------------|
|                                 | Left                       | Thru | Right | U | Left                       | Thru | Right | U | Left                     | Thru | Right | U | Left                     | Thru | Right | U |       |               |
| 6:00 AM                         | 0                          | 0    | 0     | 0 | 0                          | 0    | 1     | 0 | 0                        | 0    | 1     | 0 | 0                        | 0    | 0     | 0 | 2     |               |
| 6:05 AM                         | 0                          | 1    | 0     | 0 | 0                          | 0    | 0     | 0 | 0                        | 0    | 0     | 0 | 0                        | 0    | 0     | 0 | 1     |               |
| 6:10 AM                         | 0                          | 0    | 1     | 0 | 0                          | 0    | 0     | 0 | 0                        | 0    | 0     | 0 | 0                        | 0    | 0     | 0 | 1     |               |
| 6:15 AM                         | 0                          | 1    | 0     | 0 | 0                          | 0    | 1     | 0 | 0                        | 0    | 0     | 0 | 0                        | 0    | 0     | 0 | 2     |               |
| 6:20 AM                         | 0                          | 0    | 0     | 0 | 0                          | 0    | 1     | 0 | 0                        | 0    | 0     | 0 | 0                        | 0    | 0     | 0 | 1     |               |
| 6:25 AM                         | 0                          | 1    | 0     | 0 | 0                          | 0    | 0     | 0 | 0                        | 0    | 0     | 0 | 0                        | 0    | 0     | 0 | 1     |               |
| 6:30 AM                         | 0                          | 0    | 0     | 0 | 0                          | 0    | 0     | 0 | 0                        | 0    | 0     | 0 | 0                        | 0    | 0     | 0 | 0     |               |
| 6:35 AM                         | 0                          | 1    | 0     | 0 | 0                          | 0    | 0     | 0 | 0                        | 2    | 0     | 0 | 0                        | 0    | 0     | 0 | 3     |               |
| 6:40 AM                         | 0                          | 0    | 0     | 0 | 0                          | 1    | 0     | 0 | 0                        | 1    | 0     | 0 | 0                        | 0    | 1     | 0 | 3     |               |
| 6:45 AM                         | 0                          | 0    | 0     | 0 | 0                          | 3    | 0     | 0 | 0                        | 0    | 0     | 0 | 0                        | 0    | 0     | 0 | 3     |               |
| 6:50 AM                         | 0                          | 1    | 0     | 0 | 0                          | 1    | 0     | 0 | 0                        | 1    | 0     | 0 | 0                        | 0    | 0     | 0 | 3     |               |
| 6:55 AM                         | 0                          | 0    | 0     | 0 | 0                          | 0    | 0     | 0 | 0                        | 0    | 0     | 0 | 0                        | 0    | 0     | 0 | 0     | 20            |
| 7:00 AM                         | 0                          | 1    | 0     | 0 | 0                          | 1    | 0     | 0 | 0                        | 0    | 0     | 0 | 0                        | 1    | 0     | 0 | 3     | 21            |
| 7:05 AM                         | 0                          | 0    | 0     | 0 | 0                          | 0    | 0     | 0 | 0                        | 1    | 0     | 0 | 0                        | 0    | 1     | 0 | 2     | 22            |
| 7:10 AM                         | 0                          | 2    | 0     | 0 | 0                          | 1    | 0     | 0 | 0                        | 1    | 3     | 0 | 0                        | 0    | 0     | 0 | 7     | 28            |
| 7:15 AM                         | 0                          | 3    | 0     | 0 | 0                          | 0    | 0     | 0 | 0                        | 1    | 1     | 0 | 0                        | 0    | 0     | 0 | 5     | 31            |
| 7:20 AM                         | 0                          | 1    | 0     | 0 | 0                          | 0    | 0     | 0 | 0                        | 0    | 0     | 0 | 0                        | 1    | 0     | 0 | 2     | 32            |
| 7:25 AM                         | 0                          | 1    | 0     | 0 | 0                          | 0    | 1     | 0 | 0                        | 1    | 0     | 0 | 0                        | 0    | 0     | 0 | 3     | 34            |
| 7:30 AM                         | 1                          | 4    | 0     | 0 | 0                          | 1    | 0     | 0 | 0                        | 0    | 1     | 0 | 0                        | 0    | 0     | 0 | 7     | 41            |
| 7:35 AM                         | 0                          | 1    | 0     | 0 | 0                          | 0    | 1     | 0 | 0                        | 1    | 0     | 1 | 0                        | 0    | 0     | 0 | 4     | 42            |
| 7:40 AM                         | 0                          | 2    | 0     | 0 | 0                          | 1    | 0     | 0 | 0                        | 0    | 1     | 0 | 0                        | 0    | 0     | 0 | 4     | 43            |
| 7:45 AM                         | 1                          | 3    | 0     | 0 | 0                          | 0    | 0     | 0 | 0                        | 0    | 1     | 0 | 0                        | 0    | 0     | 0 | 5     | 45            |
| 7:50 AM                         | 0                          | 1    | 0     | 0 | 0                          | 1    | 0     | 0 | 0                        | 0    | 1     | 4 | 0                        | 1    | 0     | 0 | 8     | 50            |
| 7:55 AM                         | 2                          | 7    | 0     | 0 | 0                          | 1    | 2     | 0 | 0                        | 0    | 0     | 0 | 0                        | 0    | 1     | 0 | 13    | 63            |
| 8:00 AM                         | 0                          | 3    | 0     | 0 | 0                          | 1    | 0     | 0 | 0                        | 5    | 0     | 1 | 0                        | 0    | 0     | 0 | 10    | 70            |
| 8:05 AM                         | 0                          | 4    | 1     | 0 | 0                          | 2    | 1     | 0 | 0                        | 3    | 1     | 0 | 0                        | 0    | 0     | 0 | 12    | 80            |
| 8:10 AM                         | 0                          | 0    | 0     | 0 | 0                          | 1    | 0     | 0 | 0                        | 0    | 1     | 0 | 0                        | 0    | 0     | 0 | 2     | 75            |
| 8:15 AM                         | 0                          | 2    | 0     | 0 | 0                          | 2    | 0     | 0 | 0                        | 2    | 0     | 0 | 0                        | 0    | 0     | 0 | 6     | 76            |
| 8:20 AM                         | 0                          | 1    | 1     | 0 | 0                          | 1    | 1     | 0 | 0                        | 1    | 0     | 0 | 0                        | 0    | 0     | 0 | 5     | 79            |
| 8:25 AM                         | 0                          | 4    | 0     | 0 | 0                          | 0    | 0     | 0 | 0                        | 0    | 1     | 0 | 0                        | 0    | 0     | 0 | 5     | 81            |
| 8:30 AM                         | 0                          | 1    | 0     | 0 | 0                          | 1    | 1     | 0 | 0                        | 0    | 0     | 0 | 0                        | 0    | 0     | 0 | 3     | 77            |
| 8:35 AM                         | 0                          | 0    | 0     | 0 | 0                          | 1    | 0     | 0 | 0                        | 2    | 0     | 0 | 0                        | 0    | 0     | 0 | 3     | 76            |
| 8:40 AM                         | 0                          | 1    | 0     | 0 | 0                          | 1    | 0     | 0 | 0                        | 1    | 0     | 0 | 0                        | 0    | 0     | 0 | 3     | 75            |
| 8:45 AM                         | 0                          | 0    | 0     | 0 | 0                          | 0    | 1     | 0 | 0                        | 0    | 1     | 2 | 0                        | 0    | 0     | 0 | 4     | 74            |
| 8:50 AM                         | 0                          | 1    | 0     | 0 | 0                          | 1    | 1     | 0 | 0                        | 0    | 0     | 0 | 0                        | 0    | 0     | 0 | 3     | 69            |
| 8:55 AM                         | 0                          | 0    | 0     | 0 | 0                          | 2    | 1     | 0 | 0                        | 0    | 0     | 0 | 0                        | 0    | 0     | 0 | 3     | 59            |
| 9:00 AM                         | 0                          | 0    | 0     | 0 | 0                          | 0    | 0     | 0 | 0                        | 0    | 0     | 1 | 0                        | 0    | 0     | 0 | 1     | 50            |
| 9:05 AM                         | 0                          | 2    | 0     | 0 | 0                          | 2    | 0     | 0 | 0                        | 0    | 0     | 0 | 0                        | 0    | 0     | 0 | 4     | 42            |

Attachment B

| 5-Min Count Period Beginning At | Silver Fox Rd (Northbound) |      |       |   | Silver Fox Rd (Southbound) |      |       |   | St Albans Dr (Eastbound) |      |       |   | St Albans Dr (Westbound) |      |       |   | Total | Hourly Totals |
|---------------------------------|----------------------------|------|-------|---|----------------------------|------|-------|---|--------------------------|------|-------|---|--------------------------|------|-------|---|-------|---------------|
|                                 | Left                       | Thru | Right | U | Left                       | Thru | Right | U | Left                     | Thru | Right | U | Left                     | Thru | Right | U |       |               |
| 9:10 AM                         | 0                          | 0    | 0     | 0 | 0                          | 0    | 1     | 0 | 0                        | 0    | 0     | 0 | 0                        | 0    | 0     | 0 | 1     | 41            |
| 9:15 AM                         | 0                          | 0    | 0     | 0 | 0                          | 0    | 2     | 0 | 0                        | 0    | 0     | 0 | 0                        | 0    | 0     | 0 | 2     | 37            |
| 9:20 AM                         | 0                          | 1    | 0     | 0 | 0                          | 0    | 0     | 0 | 1                        | 0    | 0     | 0 | 0                        | 0    | 0     | 0 | 2     | 34            |
| 9:25 AM                         | 0                          | 0    | 0     | 0 | 0                          | 0    | 1     | 0 | 1                        | 0    | 1     | 0 | 0                        | 0    | 0     | 0 | 3     | 32            |
| 9:30 AM                         | 0                          | 0    | 0     | 0 | 0                          | 0    | 1     | 0 | 0                        | 0    | 1     | 0 | 0                        | 0    | 0     | 0 | 2     | 31            |
| 9:35 AM                         | 0                          | 0    | 0     | 0 | 0                          | 0    | 0     | 0 | 0                        | 0    | 0     | 0 | 0                        | 0    | 0     | 0 | 0     | 28            |
| 9:40 AM                         | 0                          | 2    | 0     | 0 | 0                          | 0    | 0     | 0 | 0                        | 0    | 0     | 0 | 0                        | 0    | 0     | 0 | 2     | 27            |
| 9:45 AM                         | 0                          | 0    | 0     | 0 | 0                          | 0    | 0     | 0 | 1                        | 0    | 0     | 0 | 0                        | 0    | 0     | 0 | 1     | 24            |
| 9:50 AM                         | 0                          | 1    | 0     | 0 | 0                          | 4    | 0     | 0 | 0                        | 0    | 0     | 0 | 0                        | 0    | 0     | 0 | 5     | 26            |
| 9:55 AM                         | 0                          | 0    | 0     | 0 | 0                          | 0    | 0     | 0 | 1                        | 0    | 0     | 0 | 0                        | 0    | 0     | 0 | 1     | 24            |
| 10:00 AM                        | 0                          | 0    | 0     | 0 | 0                          | 1    | 1     | 0 | 0                        | 0    | 0     | 0 | 0                        | 0    | 0     | 0 | 2     | 25            |
| 10:05 AM                        | 0                          | 0    | 1     | 0 | 0                          | 1    | 0     | 0 | 0                        | 0    | 0     | 0 | 1                        | 0    | 0     | 0 | 3     | 24            |
| 10:10 AM                        | 0                          | 0    | 0     | 0 | 0                          | 1    | 0     | 0 | 1                        | 1    | 0     | 0 | 0                        | 1    | 0     | 0 | 4     | 27            |
| 10:15 AM                        | 0                          | 0    | 0     | 0 | 0                          | 1    | 1     | 0 | 0                        | 1    | 0     | 0 | 0                        | 0    | 0     | 0 | 3     | 28            |
| 10:20 AM                        | 1                          | 2    | 0     | 0 | 0                          | 1    | 1     | 0 | 0                        | 0    | 0     | 0 | 0                        | 0    | 0     | 0 | 5     | 31            |
| 10:25 AM                        | 0                          | 1    | 0     | 0 | 0                          | 2    | 0     | 0 | 0                        | 0    | 0     | 0 | 0                        | 0    | 0     | 0 | 3     | 31            |
| 10:30 AM                        | 0                          | 0    | 0     | 0 | 0                          | 0    | 1     | 0 | 0                        | 0    | 0     | 0 | 0                        | 0    | 0     | 0 | 1     | 30            |
| 10:35 AM                        | 0                          | 1    | 0     | 0 | 0                          | 1    | 0     | 0 | 0                        | 0    | 1     | 0 | 0                        | 0    | 0     | 0 | 3     | 33            |
| 10:40 AM                        | 0                          | 0    | 0     | 0 | 0                          | 0    | 1     | 0 | 0                        | 1    | 0     | 0 | 0                        | 0    | 0     | 0 | 2     | 33            |
| 10:45 AM                        | 0                          | 4    | 0     | 0 | 0                          | 1    | 0     | 0 | 0                        | 0    | 0     | 0 | 0                        | 0    | 0     | 0 | 5     | 37            |
| 10:50 AM                        | 0                          | 0    | 0     | 0 | 0                          | 1    | 0     | 0 | 0                        | 0    | 0     | 0 | 0                        | 0    | 0     | 0 | 1     | 33            |
| 10:55 AM                        | 0                          | 0    | 0     | 0 | 0                          | 3    | 0     | 0 | 0                        | 0    | 1     | 0 | 0                        | 0    | 0     | 0 | 4     | 36            |
| 11:00 AM                        | 0                          | 0    | 0     | 0 | 0                          | 0    | 1     | 0 | 0                        | 2    | 2     | 0 | 0                        | 0    | 0     | 0 | 5     | 39            |
| 11:05 AM                        | 0                          | 1    | 0     | 0 | 0                          | 2    | 0     | 0 | 1                        | 0    | 0     | 0 | 0                        | 0    | 0     | 0 | 4     | 40            |
| 11:10 AM                        | 0                          | 1    | 0     | 0 | 0                          | 0    | 0     | 0 | 0                        | 0    | 0     | 0 | 0                        | 0    | 0     | 0 | 1     | 37            |
| 11:15 AM                        | 0                          | 1    | 1     | 0 | 0                          | 2    | 2     | 0 | 0                        | 0    | 0     | 0 | 1                        | 0    | 0     | 0 | 7     | 41            |
| 11:20 AM                        | 0                          | 0    | 1     | 0 | 0                          | 0    | 0     | 0 | 1                        | 0    | 2     | 0 | 0                        | 0    | 0     | 0 | 4     | 40            |
| 11:25 AM                        | 0                          | 0    | 0     | 0 | 0                          | 0    | 0     | 0 | 0                        | 0    | 1     | 0 | 0                        | 0    | 0     | 0 | 1     | 38            |
| 11:30 AM                        | 1                          | 1    | 0     | 0 | 0                          | 0    | 0     | 0 | 1                        | 0    | 0     | 0 | 0                        | 0    | 0     | 0 | 3     | 40            |
| 11:35 AM                        | 0                          | 0    | 0     | 0 | 0                          | 0    | 1     | 0 | 0                        | 0    | 1     | 0 | 0                        | 0    | 0     | 0 | 2     | 39            |
| 11:40 AM                        | 1                          | 2    | 0     | 0 | 0                          | 0    | 0     | 0 | 0                        | 1    | 1     | 0 | 0                        | 0    | 0     | 0 | 5     | 42            |
| 11:45 AM                        | 0                          | 0    | 0     | 0 | 0                          | 1    | 0     | 0 | 0                        | 1    | 0     | 0 | 0                        | 0    | 0     | 0 | 2     | 39            |
| 11:50 AM                        | 0                          | 1    | 1     | 0 | 0                          | 1    | 0     | 0 | 1                        | 0    | 0     | 0 | 0                        | 0    | 0     | 0 | 4     | 42            |
| 11:55 AM                        | 0                          | 1    | 0     | 0 | 0                          | 1    | 2     | 0 | 0                        | 0    | 0     | 0 | 1                        | 0    | 0     | 0 | 5     | 43            |
| 12:00 PM                        | 0                          | 1    | 0     | 0 | 0                          | 0    | 0     | 0 | 2                        | 0    | 1     | 0 | 0                        | 0    | 0     | 0 | 4     | 42            |
| 12:05 PM                        | 0                          | 0    | 0     | 0 | 1                          | 1    | 0     | 0 | 0                        | 1    | 0     | 0 | 0                        | 0    | 0     | 0 | 3     | 41            |
| 12:10 PM                        | 0                          | 0    | 1     | 0 | 0                          | 1    | 0     | 0 | 0                        | 0    | 1     | 0 | 0                        | 0    | 1     | 0 | 4     | 44            |
| 12:15 PM                        | 0                          | 0    | 1     | 0 | 0                          | 5    | 0     | 0 | 1                        | 0    | 0     | 0 | 1                        | 0    | 0     | 0 | 8     | 45            |
| 12:20 PM                        | 0                          | 1    | 0     | 0 | 0                          | 0    | 1     | 0 | 0                        | 0    | 0     | 0 | 0                        | 0    | 0     | 0 | 2     | 43            |
| 12:25 PM                        | 0                          | 1    | 0     | 0 | 0                          | 0    | 0     | 0 | 0                        | 0    | 0     | 0 | 0                        | 0    | 0     | 0 | 1     | 43            |
| 12:30 PM                        | 0                          | 1    | 0     | 0 | 0                          | 0    | 0     | 0 | 0                        | 0    | 1     | 0 | 0                        | 0    | 0     | 0 | 2     | 42            |
| 12:35 PM                        | 0                          | 3    | 0     | 0 | 1                          | 1    | 0     | 0 | 0                        | 0    | 0     | 0 | 0                        | 1    | 0     | 0 | 6     | 46            |
| 12:40 PM                        | 0                          | 0    | 0     | 0 | 0                          | 2    | 1     | 0 | 0                        | 0    | 1     | 0 | 0                        | 0    | 0     | 0 | 4     | 45            |
| 12:45 PM                        | 0                          | 1    | 0     | 0 | 1                          | 1    | 0     | 0 | 0                        | 0    | 0     | 0 | 0                        | 0    | 0     | 0 | 3     | 46            |
| 12:50 PM                        | 0                          | 1    | 0     | 0 | 0                          | 0    | 1     | 0 | 0                        | 2    | 2     | 0 | 0                        | 0    | 0     | 0 | 6     | 48            |
| 12:55 PM                        | 0                          | 2    | 0     | 0 | 0                          | 3    | 0     | 0 | 0                        | 0    | 0     | 0 | 0                        | 0    | 0     | 0 | 5     | 48            |
| 1:00 PM                         | 0                          | 1    | 0     | 0 | 1                          | 0    | 1     | 0 | 1                        | 0    | 0     | 0 | 0                        | 0    | 0     | 0 | 4     | 48            |
| 1:05 PM                         | 0                          | 0    | 0     | 0 | 0                          | 1    | 0     | 0 | 0                        | 0    | 0     | 0 | 0                        | 0    | 0     | 0 | 1     | 46            |
| 1:10 PM                         | 0                          | 1    | 0     | 0 | 0                          | 0    | 1     | 0 | 0                        | 0    | 1     | 0 | 1                        | 0    | 0     | 0 | 4     | 46            |
| 1:15 PM                         | 0                          | 2    | 0     | 0 | 0                          | 0    | 0     | 0 | 1                        | 0    | 3     | 0 | 0                        | 1    | 0     | 0 | 7     | 45            |
| 1:20 PM                         | 0                          | 1    | 0     | 0 | 0                          | 3    | 0     | 0 | 0                        | 0    | 0     | 0 | 0                        | 0    | 0     | 0 | 4     | 47            |
| 1:25 PM                         | 0                          | 2    | 0     | 0 | 0                          | 5    | 1     | 0 | 1                        | 0    | 0     | 0 | 0                        | 0    | 0     | 0 | 9     | 55            |
| 1:30 PM                         | 0                          | 1    | 0     | 0 | 0                          | 0    | 0     | 0 | 0                        | 0    | 1     | 0 | 0                        | 0    | 0     | 0 | 2     | 55            |
| 1:35 PM                         | 0                          | 1    | 0     | 0 | 0                          | 2    | 0     | 0 | 0                        | 1    | 0     | 0 | 0                        | 0    | 0     | 0 | 4     | 53            |
| 1:40 PM                         | 0                          | 0    | 0     | 0 | 0                          | 0    | 1     | 0 | 0                        | 0    | 0     | 0 | 0                        | 0    | 0     | 0 | 1     | 50            |
| 1:45 PM                         | 0                          | 2    | 0     | 0 | 1                          | 4    | 0     | 0 | 0                        | 1    | 1     | 0 | 0                        | 0    | 0     | 0 | 9     | 56            |
| 1:50 PM                         | 0                          | 0    | 0     | 0 | 0                          | 2    | 0     | 0 | 0                        | 0    | 0     | 0 | 0                        | 0    | 0     | 0 | 2     | 52            |
| 1:55 PM                         | 0                          | 1    | 0     | 0 | 0                          | 3    | 0     | 0 | 0                        | 0    | 1     | 0 | 0                        | 0    | 0     | 0 | 5     | 52            |
| 2:00 PM                         | 0                          | 0    | 1     | 0 | 1                          | 1    | 0     | 0 | 0                        | 1    | 0     | 0 | 1                        | 0    | 0     | 0 | 5     | 53            |
| 2:05 PM                         | 0                          | 1    | 0     | 0 | 0                          | 1    | 0     | 0 | 0                        | 2    | 1     | 0 | 1                        | 0    | 0     | 0 | 6     | 58            |
| 2:10 PM                         | 0                          | 4    | 0     | 0 | 0                          | 2    | 0     | 0 | 1                        | 1    | 1     | 0 | 0                        | 0    | 0     | 0 | 9     | 63            |
| 2:15 PM                         | 1                          | 0    | 0     | 0 | 0                          | 3    | 0     | 0 | 1                        | 2    | 0     | 0 | 0                        | 0    | 1     | 0 | 8     | 64            |
| 2:20 PM                         | 0                          | 1    | 1     | 0 | 0                          | 1    | 0     | 0 | 1                        | 0    | 0     | 0 | 0                        | 0    | 0     | 0 | 4     | 64            |
| 2:25 PM                         | 0                          | 0    | 0     | 0 | 0                          | 0    | 2     | 0 | 0                        | 0    | 1     | 0 | 0                        | 0    | 0     | 0 | 3     | 58            |
| 2:30 PM                         | 0                          | 1    | 0     | 0 | 0                          | 1    | 1     | 0 | 0                        | 1    | 0     | 0 | 1                        | 0    | 0     | 0 | 5     | 61            |
| 2:35 PM                         | 1                          | 0    | 2     | 0 | 1                          | 2    | 0     | 0 | 2                        | 0    | 0     | 0 | 0                        | 2    | 0     | 0 | 10    | 67            |
| 2:40 PM                         | 0                          | 3    | 0     | 0 | 0                          | 1    | 0     | 0 | 1                        | 1    | 1     | 0 | 0                        | 0    | 0     | 0 | 7     | 73            |
| 2:45 PM                         | 0                          | 2    | 1     | 0 | 0                          | 3    | 0     | 0 | 0                        | 0    | 2     | 0 | 0                        | 0    | 0     | 0 | 8     | 72            |
| 2:50 PM                         | 0                          | 2    | 0     | 0 | 0                          | 2    | 0     | 0 | 0                        | 0    | 0     | 0 | 0                        | 0    | 0     | 0 | 4     | 74            |
| 2:55 PM                         | 1                          | 1    | 0     | 0 | 0                          | 0    | 0     | 0 | 0                        | 1    | 0     | 0 | 0                        | 0    | 0     | 0 | 3     | 72            |
| 3:00 PM                         | 0                          | 2    | 0     | 0 | 0                          | 2    | 0     | 0 | 1                        | 0    | 0     | 0 | 0                        | 0    | 0     | 0 | 5     | 72            |
| 3:05 PM                         | 1                          | 1    | 0     | 0 | 0                          | 0    | 0     | 0 | 0                        | 0    | 0     | 0 | 0                        | 0    | 1     | 0 | 3     | 69            |
| 3:10 PM                         | 0                          | 2    | 0     | 0 | 0                          | 0    | 1     | 0 | 0                        | 1    | 1     | 0 | 0                        | 0    | 0     | 0 | 5     | 65            |
| 3:15 PM                         | 1                          | 1    | 0     | 0 | 0                          | 3    | 2     | 0 | 1                        | 0    | 0     | 0 | 0                        | 0    | 0     | 0 | 8     | 65            |
| 3:20 PM                         | 1                          | 0    | 0     | 0 | 0                          | 0    | 1     | 0 | 1                        | 0    | 0     | 0 | 0                        | 0    | 0     | 0 | 3     | 64            |
| 3:25 PM                         | 0                          | 2    | 0     | 0 | 0                          | 1    | 2     | 0 | 1                        | 0    | 0     | 0 | 0                        | 0    | 0     | 0 | 6     | 67            |
| 3:30 PM                         | 0                          | 1    | 0     | 0 | 0                          | 2    | 1     | 0 | 0                        | 0    | 1     | 0 | 0                        | 0    | 0     | 0 | 5     | 67            |
| 3:35 PM                         | 0                          | 3    | 0     | 0 | 0                          | 1    | 0     | 0 | 0                        | 0    | 0     | 0 | 0                        | 0    | 0     | 0 | 4     | 61            |
| 3:40 PM                         | 1                          | 0    | 0     | 0 | 0                          | 1    | 2     | 0 | 0                        | 0    | 0     | 0 | 0                        | 0    | 0     | 0 | 4     | 58            |
| 3:45 PM                         | 0                          | 2    | 0     | 0 | 0                          | 1    | 0     | 0 | 0                        | 0    | 0     | 0 | 1                        | 0    | 0     | 0 | 4     | 54            |
| 3:50 PM                         | 0                          | 3    | 0     | 0 | 0                          | 0    | 0     | 0 | 0                        | 1    | 0     | 0 | 0                        | 0    | 0     | 0 | 4     | 54            |
| 3:55 PM                         | 0                          | 1    | 0     | 0 | 0                          | 3    | 2     | 0 | 0                        | 0    | 0     | 0 | 0                        | 0    | 0     | 0 | 6     | 57            |
| 4:00 PM                         | 0                          | 0    | 0     | 0 | 0                          | 0    | 0     | 0 | 1                        | 1    | 1     | 0 | 0                        | 0    | 0     | 0 | 3     | 55            |
| 4:05 PM                         | 0                          | 5    | 0     | 0 | 0                          | 3    | 0     | 0 | 2                        | 2    | 0     | 0 | 0                        | 0    | 0     | 0 | 12    | 64            |
| 4:10 PM                         | 0                          | 1    | 1     | 0 | 0                          | 0    | 0     | 0 | 1                        | 0    | 0     | 0 | 1                        | 0    | 0     | 0 | 4     | 63            |
| 4:15 PM                         | 0                          | 4    | 1     | 0 | 0                          | 1    | 0     | 0 | 0                        | 0    | 0     | 0 | 0                        | 0    | 0     | 0 | 6     | 61            |
| 4:20 PM                         | 0                          | 4    | 0     | 0 | 0                          | 0    | 0     | 0 | 0                        | 0    | 0     | 0 | 0                        | 0    | 0     | 0 | 4     | 62            |
| 4:25 PM                         | 0                          | 1    | 0     | 0 | 0                          | 4    | 0     | 0 | 3                        | 0    | 0     | 0 | 0                        | 0    | 0     | 0 | 8     | 64            |
| 4:30 PM                         | 0                          | 3    | 0     | 0 | 0                          | 5    | 2     | 0 | 1                        | 0    | 0     | 0 | 0                        | 2    | 1     | 0 | 14    | 73            |

**Attachment B**

| 5-Min Count Period Beginning At | Silver Fox Rd (Northbound) |      |       |   | Silver Fox Rd (Southbound) |      |       |   | St Albans Dr (Eastbound) |      |       |   | St Albans Dr (Westbound) |      |       |   | Total | Hourly Totals |    |
|---------------------------------|----------------------------|------|-------|---|----------------------------|------|-------|---|--------------------------|------|-------|---|--------------------------|------|-------|---|-------|---------------|----|
|                                 | Left                       | Thru | Right | U | Left                       | Thru | Right | U | Left                     | Thru | Right | U | Left                     | Thru | Right | U |       |               |    |
| 4:35 PM                         | 0                          | 1    | 0     | 0 | 0                          | 1    | 0     | 0 | 0                        | 1    | 1     | 1 | 0                        | 0    | 0     | 0 | 0     | 4             | 73 |
| 4:40 PM                         | 0                          | 3    | 0     | 0 | 0                          | 1    | 0     | 0 | 0                        | 1    | 0     | 1 | 0                        | 0    | 0     | 0 | 0     | 6             | 75 |
| 4:45 PM                         | 1                          | 1    | 0     | 0 | 0                          | 1    | 0     | 0 | 0                        | 0    | 1     | 0 | 0                        | 0    | 0     | 0 | 0     | 4             | 75 |
| 4:50 PM                         | 0                          | 0    | 0     | 0 | 0                          | 3    | 1     | 0 | 0                        | 0    | 0     | 1 | 0                        | 0    | 0     | 0 | 0     | 5             | 76 |
| 4:55 PM                         | 0                          | 3    | 0     | 0 | 0                          | 1    | 1     | 0 | 0                        | 0    | 0     | 0 | 0                        | 0    | 0     | 0 | 0     | 5             | 75 |
| 5:00 PM                         | 0                          | 3    | 0     | 0 | 0                          | 1    | 2     | 0 | 0                        | 1    | 0     | 1 | 0                        | 0    | 0     | 0 | 0     | 8             | 80 |
| 5:05 PM                         | 0                          | 0    | 0     | 0 | 0                          | 1    | 1     | 0 | 0                        | 1    | 0     | 0 | 0                        | 0    | 0     | 0 | 0     | 3             | 71 |
| 5:10 PM                         | 0                          | 2    | 0     | 0 | 0                          | 1    | 0     | 0 | 0                        | 1    | 1     | 0 | 0                        | 0    | 0     | 0 | 0     | 5             | 72 |
| 5:15 PM                         | 0                          | 1    | 0     | 0 | 0                          | 5    | 0     | 0 | 0                        | 1    | 0     | 1 | 0                        | 0    | 0     | 0 | 0     | 8             | 74 |
| 5:20 PM                         | 0                          | 0    | 0     | 0 | 0                          | 1    | 1     | 0 | 0                        | 1    | 0     | 0 | 0                        | 0    | 0     | 0 | 0     | 3             | 73 |
| 5:25 PM                         | 0                          | 1    | 0     | 0 | 0                          | 0    | 0     | 0 | 0                        | 1    | 0     | 0 | 0                        | 0    | 0     | 0 | 0     | 2             | 67 |
| 5:30 PM                         | 0                          | 3    | 0     | 0 | 0                          | 3    | 1     | 0 | 0                        | 0    | 1     | 1 | 0                        | 0    | 0     | 1 | 0     | 10            | 63 |
| 5:35 PM                         | 0                          | 5    | 0     | 0 | 0                          | 1    | 1     | 0 | 0                        | 0    | 0     | 0 | 0                        | 0    | 0     | 0 | 0     | 7             | 66 |
| 5:40 PM                         | 1                          | 3    | 0     | 0 | 0                          | 1    | 0     | 0 | 0                        | 0    | 0     | 1 | 0                        | 0    | 0     | 0 | 0     | 6             | 66 |
| 5:45 PM                         | 0                          | 1    | 0     | 0 | 0                          | 0    | 0     | 0 | 0                        | 2    | 1     | 0 | 0                        | 1    | 0     | 0 | 0     | 5             | 67 |
| 5:50 PM                         | 0                          | 1    | 0     | 0 | 0                          | 1    | 1     | 0 | 0                        | 1    | 0     | 0 | 0                        | 0    | 0     | 0 | 0     | 4             | 66 |
| 5:55 PM                         | 1                          | 0    | 0     | 0 | 0                          | 0    | 1     | 0 | 0                        | 0    | 0     | 0 | 0                        | 0    | 0     | 0 | 0     | 2             | 63 |
| 6:00 PM                         | 0                          | 1    | 1     | 0 | 0                          | 1    | 1     | 0 | 0                        | 1    | 0     | 0 | 0                        | 0    | 0     | 0 | 0     | 5             | 60 |
| 6:05 PM                         | 0                          | 1    | 0     | 0 | 0                          | 3    | 1     | 0 | 0                        | 1    | 0     | 1 | 0                        | 0    | 0     | 0 | 0     | 7             | 64 |
| 6:10 PM                         | 1                          | 2    | 0     | 0 | 0                          | 1    | 1     | 0 | 0                        | 0    | 0     | 0 | 0                        | 0    | 0     | 0 | 0     | 5             | 64 |
| 6:15 PM                         | 0                          | 1    | 0     | 0 | 0                          | 0    | 2     | 0 | 0                        | 1    | 0     | 0 | 0                        | 0    | 0     | 0 | 0     | 4             | 60 |
| 6:20 PM                         | 1                          | 1    | 0     | 0 | 0                          | 1    | 1     | 0 | 0                        | 0    | 0     | 0 | 0                        | 0    | 1     | 0 | 0     | 5             | 62 |
| 6:25 PM                         | 0                          | 1    | 0     | 0 | 0                          | 1    | 0     | 0 | 0                        | 0    | 0     | 0 | 0                        | 0    | 0     | 0 | 0     | 2             | 62 |
| 6:30 PM                         | 0                          | 3    | 0     | 0 | 0                          | 1    | 2     | 0 | 0                        | 1    | 0     | 0 | 0                        | 0    | 0     | 0 | 0     | 7             | 59 |
| 6:35 PM                         | 0                          | 2    | 0     | 0 | 0                          | 1    | 0     | 0 | 0                        | 1    | 0     | 0 | 0                        | 0    | 0     | 0 | 0     | 4             | 56 |
| 6:40 PM                         | 0                          | 2    | 0     | 0 | 0                          | 2    | 1     | 0 | 0                        | 1    | 0     | 0 | 0                        | 0    | 0     | 0 | 0     | 6             | 56 |
| 6:45 PM                         | 0                          | 0    | 0     | 0 | 0                          | 1    | 1     | 0 | 0                        | 1    | 1     | 0 | 0                        | 0    | 0     | 0 | 0     | 4             | 55 |
| 6:50 PM                         | 0                          | 0    | 0     | 0 | 0                          | 0    | 2     | 0 | 0                        | 0    | 0     | 0 | 0                        | 0    | 0     | 0 | 0     | 2             | 53 |
| 6:55 PM                         | 0                          | 0    | 0     | 0 | 0                          | 1    | 0     | 0 | 0                        | 0    | 0     | 2 | 0                        | 0    | 0     | 0 | 0     | 3             | 54 |
| 7:00 PM                         | 1                          | 2    | 0     | 0 | 0                          | 3    | 0     | 0 | 0                        | 0    | 1     | 0 | 0                        | 0    | 0     | 0 | 0     | 7             | 56 |
| 7:05 PM                         | 0                          | 0    | 0     | 0 | 0                          | 1    | 0     | 0 | 0                        | 0    | 1     | 1 | 0                        | 0    | 0     | 0 | 0     | 3             | 52 |
| 7:10 PM                         | 0                          | 1    | 0     | 0 | 0                          | 0    | 1     | 0 | 0                        | 1    | 0     | 0 | 0                        | 0    | 0     | 0 | 0     | 3             | 50 |
| 7:15 PM                         | 1                          | 0    | 0     | 0 | 0                          | 1    | 1     | 0 | 0                        | 1    | 0     | 1 | 0                        | 1    | 0     | 0 | 0     | 6             | 52 |
| 7:20 PM                         | 0                          | 0    | 0     | 0 | 0                          | 1    | 1     | 0 | 0                        | 0    | 1     | 0 | 0                        | 1    | 0     | 0 | 0     | 4             | 51 |
| 7:25 PM                         | 0                          | 2    | 0     | 0 | 0                          | 0    | 1     | 0 | 0                        | 0    | 0     | 1 | 0                        | 0    | 0     | 1 | 0     | 5             | 54 |
| 7:30 PM                         | 0                          | 1    | 0     | 0 | 0                          | 0    | 0     | 0 | 0                        | 0    | 0     | 0 | 0                        | 0    | 0     | 0 | 0     | 1             | 48 |
| 7:35 PM                         | 1                          | 1    | 0     | 0 | 1                          | 1    | 0     | 0 | 0                        | 0    | 0     | 0 | 0                        | 0    | 0     | 0 | 0     | 4             | 48 |
| 7:40 PM                         | 1                          | 0    | 0     | 0 | 0                          | 0    | 0     | 0 | 0                        | 2    | 0     | 0 | 0                        | 0    | 0     | 0 | 0     | 3             | 45 |
| 7:45 PM                         | 0                          | 0    | 0     | 0 | 0                          | 2    | 0     | 0 | 0                        | 0    | 0     | 0 | 0                        | 0    | 0     | 0 | 0     | 2             | 43 |
| 7:50 PM                         | 0                          | 3    | 0     | 0 | 0                          | 2    | 0     | 0 | 0                        | 0    | 0     | 0 | 0                        | 0    | 0     | 0 | 0     | 5             | 46 |
| 7:55 PM                         | 0                          | 0    | 0     | 0 | 0                          | 0    | 1     | 0 | 0                        | 1    | 0     | 0 | 0                        | 0    | 0     | 0 | 0     | 2             | 45 |
| 8:00 PM                         | 2                          | 0    | 0     | 0 | 0                          | 1    | 0     | 0 | 0                        | 0    | 1     | 0 | 0                        | 0    | 0     | 0 | 0     | 4             | 42 |
| 8:05 PM                         | 0                          | 0    | 0     | 0 | 0                          | 3    | 0     | 0 | 0                        | 1    | 0     | 1 | 0                        | 0    | 0     | 0 | 0     | 5             | 44 |
| 8:10 PM                         | 0                          | 1    | 0     | 0 | 0                          | 4    | 0     | 0 | 0                        | 1    | 0     | 0 | 0                        | 0    | 0     | 0 | 0     | 6             | 47 |
| 8:15 PM                         | 0                          | 0    | 0     | 0 | 0                          | 1    | 1     | 0 | 0                        | 0    | 0     | 1 | 0                        | 0    | 0     | 0 | 0     | 3             | 44 |
| 8:20 PM                         | 0                          | 0    | 0     | 0 | 0                          | 1    | 0     | 0 | 0                        | 0    | 0     | 0 | 0                        | 0    | 0     | 0 | 0     | 1             | 41 |
| 8:25 PM                         | 0                          | 0    | 0     | 0 | 0                          | 0    | 2     | 0 | 0                        | 0    | 0     | 0 | 0                        | 0    | 0     | 0 | 0     | 2             | 38 |
| 8:30 PM                         | 0                          | 1    | 0     | 0 | 0                          | 1    | 1     | 0 | 0                        | 0    | 0     | 0 | 0                        | 0    | 0     | 0 | 0     | 3             | 40 |
| 8:35 PM                         | 0                          | 1    | 0     | 0 | 0                          | 0    | 1     | 0 | 0                        | 0    | 1     | 0 | 0                        | 0    | 0     | 0 | 0     | 3             | 39 |
| 8:40 PM                         | 0                          | 0    | 0     | 0 | 0                          | 0    | 0     | 0 | 0                        | 0    | 0     | 0 | 0                        | 0    | 0     | 0 | 0     | 0             | 36 |
| 8:45 PM                         | 0                          | 0    | 0     | 0 | 0                          | 0    | 1     | 0 | 0                        | 0    | 0     | 0 | 0                        | 0    | 0     | 0 | 0     | 1             | 35 |
| 8:50 PM                         | 0                          | 0    | 0     | 0 | 0                          | 0    | 1     | 0 | 0                        | 0    | 0     | 0 | 0                        | 0    | 0     | 0 | 0     | 1             | 31 |
| 8:55 PM                         | 0                          | 0    | 0     | 0 | 0                          | 0    | 1     | 0 | 0                        | 0    | 0     | 0 | 0                        | 0    | 0     | 0 | 0     | 1             | 30 |
| 9:00 PM                         | 0                          | 0    | 0     | 0 | 0                          | 0    | 1     | 0 | 0                        | 0    | 0     | 0 | 0                        | 0    | 0     | 0 | 0     | 1             | 27 |
| 9:05 PM                         | 0                          | 0    | 0     | 0 | 0                          | 0    | 0     | 0 | 0                        | 0    | 0     | 0 | 0                        | 0    | 0     | 0 | 0     | 0             | 22 |
| 9:10 PM                         | 0                          | 0    | 0     | 0 | 0                          | 0    | 1     | 0 | 0                        | 0    | 0     | 0 | 0                        | 0    | 0     | 0 | 0     | 1             | 17 |
| 9:15 PM                         | 0                          | 0    | 0     | 0 | 0                          | 0    | 0     | 0 | 0                        | 0    | 0     | 0 | 0                        | 0    | 0     | 0 | 0     | 0             | 14 |
| 9:20 PM                         | 0                          | 1    | 0     | 0 | 0                          | 0    | 0     | 0 | 0                        | 0    | 0     | 0 | 0                        | 0    | 0     | 0 | 0     | 1             | 14 |
| 9:25 PM                         | 0                          | 0    | 0     | 0 | 0                          | 2    | 0     | 0 | 0                        | 0    | 0     | 0 | 0                        | 0    | 0     | 0 | 0     | 2             | 14 |
| 9:30 PM                         | 0                          | 1    | 0     | 0 | 0                          | 0    | 0     | 0 | 0                        | 0    | 0     | 0 | 0                        | 0    | 0     | 0 | 0     | 1             | 12 |
| 9:35 PM                         | 0                          | 0    | 0     | 0 | 0                          | 0    | 0     | 0 | 0                        | 1    | 0     | 0 | 0                        | 0    | 0     | 0 | 0     | 1             | 10 |
| 9:40 PM                         | 0                          | 1    | 0     | 0 | 0                          | 0    | 0     | 0 | 0                        | 0    | 0     | 0 | 0                        | 0    | 0     | 0 | 0     | 1             | 11 |
| 9:45 PM                         | 0                          | 0    | 0     | 0 | 0                          | 1    | 0     | 0 | 0                        | 0    | 0     | 0 | 0                        | 0    | 0     | 0 | 0     | 1             | 11 |
| 9:50 PM                         | 1                          | 0    | 0     | 0 | 0                          | 0    | 0     | 0 | 0                        | 0    | 0     | 0 | 0                        | 0    | 0     | 0 | 0     | 1             | 11 |
| 9:55 PM                         | 0                          | 0    | 0     | 0 | 0                          | 1    | 0     | 0 | 0                        | 0    | 0     | 0 | 0                        | 0    | 0     | 0 | 0     | 1             | 11 |
| Peak 15-Min Flowrates           | Northbound                 |      |       |   | Southbound                 |      |       |   | Eastbound                |      |       |   | Westbound                |      |       |   | Total |               |    |
|                                 | Left                       | Thru | Right | U | Left                       | Thru | Right | U | Left                     | Thru | Right | U | Left                     | Thru | Right | U |       |               |    |
| All Vehicles                    | 8                          | 56   | 4     | 0 | 0                          | 16   | 12    | 0 | 32                       | 4    | 4     | 0 | 0                        | 4    | 0     | 0 | 0     | 140           |    |
| Heavy Trucks                    | 0                          | 0    | 0     | 0 | 0                          | 0    | 0     | 0 | 0                        | 0    | 0     | 0 | 0                        | 0    | 0     | 0 | 0     | 0             |    |
| Buses                           |                            |      |       |   |                            |      |       |   |                          |      |       |   |                          |      |       |   |       |               |    |
| Pedestrians                     |                            | 0    |       |   |                            | 0    |       |   |                          | 8    |       |   |                          | 8    |       |   |       | 16            |    |
| Bicycles                        | 0                          | 0    | 0     |   | 0                          | 0    | 0     |   | 0                        | 0    | 0     |   | 0                        | 0    | 0     |   |       | 0             |    |
| Scoters                         |                            |      |       |   |                            |      |       |   |                          |      |       |   |                          |      |       |   |       |               |    |
| <i>Comments:</i>                |                            |      |       |   |                            |      |       |   |                          |      |       |   |                          |      |       |   |       |               |    |

LOCATION: Kensington Rd -- Shakespeare Dr  
 CITY/STATE: Rossmore, CA

QC JOB #: 16966416  
 DATE: Wed, Apr 9 2025

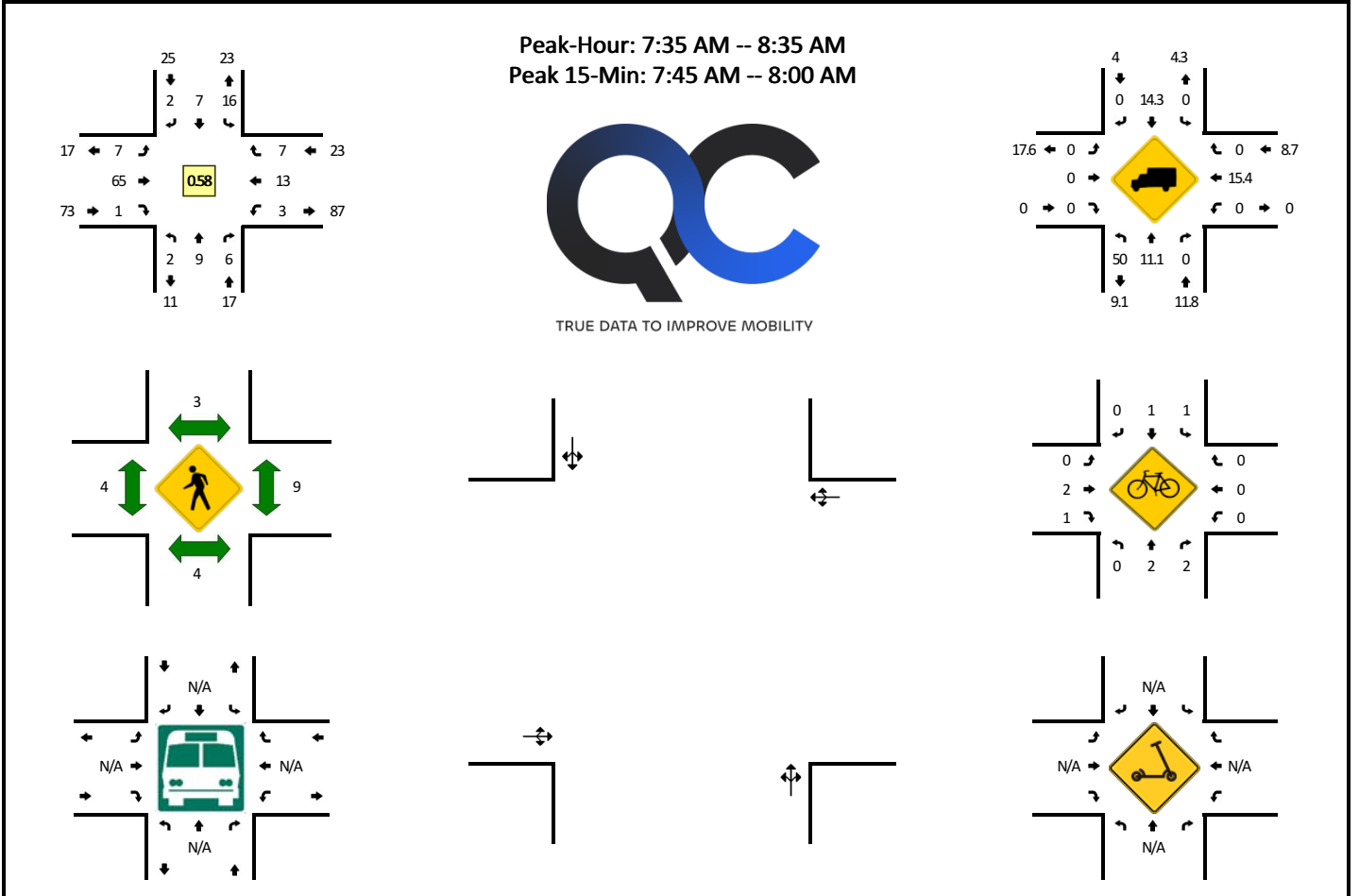

| 5-Min Count Period Beginning At | Kensington Rd (Northbound) |      |       |   | Kensington Rd (Southbound) |      |       |   | Shakespeare Dr (Eastbound) |      |       |   | Shakespeare Dr (Westbound) |      |       |   | Total | Hourly Totals |     |
|---------------------------------|----------------------------|------|-------|---|----------------------------|------|-------|---|----------------------------|------|-------|---|----------------------------|------|-------|---|-------|---------------|-----|
|                                 | Left                       | Thru | Right | U | Left                       | Thru | Right | U | Left                       | Thru | Right | U | Left                       | Thru | Right | U |       |               |     |
| 6:00 AM                         | 0                          | 0    | 1     | 0 | 1                          | 0    | 0     | 0 | 0                          | 1    | 0     | 0 | 0                          | 0    | 0     | 0 | 0     | 3             |     |
| 6:05 AM                         | 0                          | 0    | 1     | 0 | 0                          | 1    | 0     | 0 | 0                          | 0    | 0     | 0 | 0                          | 0    | 0     | 0 | 0     | 2             |     |
| 6:10 AM                         | 0                          | 1    | 0     | 0 | 0                          | 0    | 0     | 0 | 0                          | 0    | 0     | 0 | 0                          | 0    | 0     | 0 | 0     | 1             |     |
| 6:15 AM                         | 0                          | 0    | 0     | 0 | 0                          | 0    | 0     | 0 | 0                          | 0    | 1     | 0 | 0                          | 0    | 1     | 0 | 0     | 2             |     |
| 6:20 AM                         | 0                          | 0    | 0     | 0 | 0                          | 0    | 0     | 0 | 0                          | 1    | 0     | 0 | 0                          | 0    | 0     | 0 | 0     | 1             |     |
| 6:25 AM                         | 0                          | 0    | 0     | 0 | 0                          | 0    | 0     | 0 | 0                          | 0    | 1     | 0 | 0                          | 0    | 0     | 0 | 0     | 1             |     |
| 6:30 AM                         | 0                          | 0    | 1     | 0 | 0                          | 0    | 0     | 0 | 0                          | 0    | 0     | 1 | 0                          | 0    | 0     | 0 | 0     | 2             |     |
| 6:35 AM                         | 0                          | 1    | 0     | 0 | 0                          | 0    | 0     | 0 | 0                          | 1    | 0     | 0 | 0                          | 0    | 0     | 0 | 0     | 2             |     |
| 6:40 AM                         | 0                          | 0    | 0     | 0 | 0                          | 0    | 0     | 0 | 0                          | 0    | 0     | 0 | 0                          | 0    | 0     | 0 | 0     | 0             |     |
| 6:45 AM                         | 0                          | 0    | 0     | 0 | 0                          | 0    | 0     | 0 | 0                          | 0    | 0     | 0 | 0                          | 1    | 0     | 0 | 0     | 1             |     |
| 6:50 AM                         | 0                          | 0    | 0     | 0 | 0                          | 0    | 0     | 0 | 0                          | 0    | 3     | 0 | 0                          | 2    | 0     | 0 | 0     | 5             |     |
| 6:55 AM                         | 0                          | 0    | 0     | 0 | 1                          | 0    | 0     | 0 | 0                          | 0    | 1     | 0 | 0                          | 1    | 0     | 0 | 0     | 3             | 23  |
| 7:00 AM                         | 0                          | 0    | 1     | 0 | 0                          | 0    | 1     | 0 | 0                          | 0    | 0     | 0 | 0                          | 0    | 0     | 0 | 0     | 2             | 22  |
| 7:05 AM                         | 0                          | 1    | 0     | 0 | 0                          | 0    | 0     | 0 | 0                          | 0    | 0     | 1 | 0                          | 1    | 0     | 0 | 0     | 3             | 23  |
| 7:10 AM                         | 0                          | 0    | 1     | 0 | 1                          | 0    | 0     | 0 | 0                          | 0    | 3     | 0 | 0                          | 1    | 0     | 0 | 0     | 6             | 28  |
| 7:15 AM                         | 0                          | 1    | 0     | 0 | 0                          | 0    | 0     | 0 | 0                          | 0    | 0     | 0 | 0                          | 0    | 0     | 0 | 0     | 1             | 27  |
| 7:20 AM                         | 0                          | 1    | 0     | 0 | 0                          | 0    | 0     | 0 | 0                          | 0    | 0     | 0 | 0                          | 0    | 0     | 0 | 0     | 1             | 27  |
| 7:25 AM                         | 0                          | 1    | 1     | 0 | 0                          | 0    | 0     | 0 | 0                          | 2    | 0     | 0 | 0                          | 0    | 0     | 0 | 0     | 4             | 30  |
| 7:30 AM                         | 0                          | 0    | 0     | 0 | 0                          | 1    | 0     | 0 | 0                          | 0    | 4     | 0 | 0                          | 0    | 0     | 0 | 0     | 5             | 33  |
| 7:35 AM                         | 0                          | 0    | 0     | 0 | 1                          | 1    | 0     | 0 | 0                          | 0    | 2     | 1 | 0                          | 0    | 2     | 0 | 0     | 7             | 38  |
| 7:40 AM                         | 0                          | 0    | 0     | 0 | 1                          | 0    | 0     | 0 | 0                          | 0    | 9     | 0 | 0                          | 1    | 1     | 0 | 0     | 12            | 50  |
| 7:45 AM                         | 0                          | 1    | 2     | 0 | 2                          | 3    | 0     | 0 | 0                          | 0    | 9     | 0 | 0                          | 0    | 1     | 0 | 0     | 18            | 67  |
| 7:50 AM                         | 0                          | 0    | 0     | 0 | 3                          | 0    | 1     | 0 | 0                          | 1    | 10    | 0 | 0                          | 1    | 3     | 1 | 0     | 20            | 82  |
| 7:55 AM                         | 0                          | 3    | 0     | 0 | 4                          | 1    | 0     | 0 | 0                          | 2    | 10    | 0 | 0                          | 0    | 0     | 2 | 0     | 22            | 101 |
| 8:00 AM                         | 1                          | 1    | 2     | 0 | 2                          | 0    | 0     | 0 | 0                          | 0    | 8     | 0 | 0                          | 0    | 2     | 0 | 0     | 16            | 115 |
| 8:05 AM                         | 1                          | 0    | 0     | 0 | 0                          | 0    | 0     | 0 | 0                          | 1    | 2     | 0 | 0                          | 0    | 2     | 2 | 0     | 8             | 120 |
| 8:10 AM                         | 0                          | 1    | 1     | 0 | 0                          | 0    | 1     | 0 | 0                          | 2    | 6     | 0 | 0                          | 1    | 0     | 0 | 0     | 12            | 126 |
| 8:15 AM                         | 0                          | 1    | 0     | 0 | 1                          | 0    | 0     | 0 | 0                          | 0    | 2     | 0 | 0                          | 0    | 0     | 0 | 0     | 4             | 129 |
| 8:20 AM                         | 0                          | 1    | 0     | 0 | 0                          | 1    | 0     | 0 | 0                          | 0    | 3     | 0 | 0                          | 0    | 0     | 1 | 0     | 6             | 134 |
| 8:25 AM                         | 0                          | 0    | 1     | 0 | 1                          | 0    | 0     | 0 | 0                          | 0    | 2     | 0 | 0                          | 0    | 0     | 1 | 0     | 5             | 135 |
| 8:30 AM                         | 0                          | 1    | 0     | 0 | 1                          | 1    | 0     | 0 | 0                          | 1    | 2     | 0 | 0                          | 1    | 1     | 0 | 0     | 8             | 138 |
| 8:35 AM                         | 0                          | 0    | 0     | 0 | 0                          | 0    | 0     | 0 | 0                          | 0    | 3     | 0 | 0                          | 0    | 0     | 0 | 0     | 3             | 134 |
| 8:40 AM                         | 0                          | 1    | 1     | 0 | 0                          | 1    | 0     | 0 | 0                          | 0    | 0     | 0 | 0                          | 0    | 0     | 1 | 0     | 4             | 126 |
| 8:45 AM                         | 0                          | 0    | 0     | 0 | 0                          | 0    | 0     | 0 | 0                          | 0    | 1     | 0 | 0                          | 1    | 0     | 0 | 0     | 2             | 110 |
| 8:50 AM                         | 0                          | 0    | 0     | 0 | 1                          | 1    | 0     | 0 | 0                          | 0    | 0     | 0 | 0                          | 0    | 0     | 0 | 0     | 2             | 92  |
| 8:55 AM                         | 0                          | 0    | 1     | 0 | 0                          | 0    | 2     | 0 | 0                          | 0    | 1     | 0 | 0                          | 0    | 1     | 0 | 0     | 5             | 75  |
| 9:00 AM                         | 0                          | 0    | 1     | 0 | 0                          | 0    | 0     | 0 | 0                          | 0    | 0     | 0 | 0                          | 0    | 0     | 0 | 0     | 1             | 60  |
| 9:05 AM                         | 0                          | 1    | 0     | 0 | 0                          | 0    | 0     | 0 | 0                          | 0    | 1     | 0 | 0                          | 0    | 0     | 0 | 0     | 2             | 54  |

### Attachment B

| 5-Min Count Period Beginning At | Kensington Rd (Northbound) |      |       |   | Kensington Rd (Southbound) |      |       |   | Shakespeare Dr (Eastbound) |      |       |   | Shakespeare Dr (Westbound) |      |       |   | Total | Hourly Totals |
|---------------------------------|----------------------------|------|-------|---|----------------------------|------|-------|---|----------------------------|------|-------|---|----------------------------|------|-------|---|-------|---------------|
|                                 | Left                       | Thru | Right | U | Left                       | Thru | Right | U | Left                       | Thru | Right | U | Left                       | Thru | Right | U |       |               |
| 9:10 AM                         | 0                          | 0    | 1     | 0 | 0                          | 0    | 0     | 0 | 0                          | 0    | 0     | 0 | 0                          | 0    | 0     | 0 | 1     | 43            |
| 9:15 AM                         | 0                          | 1    | 0     | 0 | 0                          | 0    | 0     | 0 | 0                          | 0    | 0     | 0 | 0                          | 0    | 0     | 0 | 1     | 40            |
| 9:20 AM                         | 0                          | 0    | 1     | 0 | 0                          | 0    | 0     | 0 | 0                          | 0    | 1     | 0 | 0                          | 0    | 0     | 0 | 2     | 36            |
| 9:25 AM                         | 0                          | 0    | 0     | 0 | 1                          | 0    | 0     | 0 | 0                          | 0    | 2     | 0 | 0                          | 0    | 2     | 0 | 5     | 36            |
| 9:30 AM                         | 0                          | 0    | 0     | 0 | 1                          | 0    | 0     | 0 | 0                          | 0    | 0     | 0 | 0                          | 0    | 1     | 1 | 3     | 31            |
| 9:35 AM                         | 0                          | 0    | 0     | 0 | 0                          | 0    | 0     | 0 | 0                          | 0    | 1     | 0 | 0                          | 0    | 0     | 0 | 1     | 29            |
| 9:40 AM                         | 0                          | 0    | 1     | 0 | 0                          | 3    | 0     | 0 | 0                          | 1    | 2     | 0 | 0                          | 0    | 2     | 0 | 9     | 34            |
| 9:45 AM                         | 0                          | 0    | 0     | 0 | 0                          | 0    | 0     | 0 | 0                          | 0    | 0     | 0 | 0                          | 1    | 1     | 0 | 2     | 34            |
| 9:50 AM                         | 0                          | 0    | 0     | 0 | 0                          | 0    | 0     | 0 | 0                          | 0    | 0     | 0 | 0                          | 0    | 0     | 1 | 1     | 33            |
| 9:55 AM                         | 0                          | 1    | 0     | 0 | 0                          | 1    | 0     | 0 | 0                          | 0    | 1     | 0 | 0                          | 0    | 0     | 0 | 3     | 31            |
| 10:00 AM                        | 0                          | 1    | 0     | 0 | 1                          | 0    | 1     | 0 | 0                          | 0    | 3     | 0 | 0                          | 1    | 0     | 0 | 7     | 37            |
| 10:05 AM                        | 0                          | 0    | 0     | 0 | 0                          | 0    | 0     | 0 | 0                          | 0    | 1     | 0 | 0                          | 0    | 0     | 1 | 2     | 37            |
| 10:10 AM                        | 0                          | 0    | 0     | 0 | 0                          | 0    | 0     | 0 | 0                          | 0    | 0     | 0 | 0                          | 0    | 0     | 0 | 0     | 36            |
| 10:15 AM                        | 0                          | 0    | 0     | 0 | 0                          | 0    | 0     | 0 | 0                          | 0    | 0     | 0 | 0                          | 0    | 2     | 0 | 2     | 37            |
| 10:20 AM                        | 0                          | 0    | 0     | 0 | 0                          | 0    | 0     | 0 | 0                          | 0    | 2     | 0 | 0                          | 1    | 0     | 0 | 3     | 38            |
| 10:25 AM                        | 0                          | 0    | 0     | 0 | 0                          | 0    | 0     | 0 | 0                          | 0    | 0     | 0 | 0                          | 0    | 1     | 0 | 1     | 34            |
| 10:30 AM                        | 0                          | 0    | 0     | 0 | 0                          | 0    | 1     | 0 | 0                          | 0    | 0     | 0 | 0                          | 0    | 0     | 0 | 1     | 32            |
| 10:35 AM                        | 0                          | 0    | 0     | 0 | 1                          | 0    | 1     | 0 | 0                          | 0    | 3     | 0 | 0                          | 0    | 2     | 0 | 7     | 38            |
| 10:40 AM                        | 0                          | 0    | 0     | 0 | 0                          | 0    | 0     | 0 | 0                          | 0    | 0     | 0 | 0                          | 0    | 2     | 0 | 2     | 31            |
| 10:45 AM                        | 0                          | 0    | 0     | 0 | 1                          | 1    | 0     | 0 | 0                          | 1    | 2     | 0 | 0                          | 0    | 2     | 0 | 7     | 36            |
| 10:50 AM                        | 0                          | 0    | 0     | 0 | 0                          | 0    | 0     | 0 | 0                          | 1    | 1     | 0 | 0                          | 0    | 1     | 0 | 3     | 38            |
| 10:55 AM                        | 0                          | 0    | 0     | 0 | 0                          | 0    | 0     | 0 | 0                          | 0    | 1     | 0 | 0                          | 0    | 1     | 1 | 3     | 38            |
| 11:00 AM                        | 0                          | 2    | 0     | 0 | 0                          | 1    | 0     | 0 | 0                          | 0    | 0     | 0 | 0                          | 0    | 0     | 0 | 3     | 34            |
| 11:05 AM                        | 0                          | 1    | 0     | 0 | 0                          | 0    | 0     | 0 | 0                          | 0    | 3     | 0 | 0                          | 1    | 0     | 0 | 5     | 37            |
| 11:10 AM                        | 1                          | 0    | 0     | 0 | 0                          | 0    | 0     | 0 | 0                          | 0    | 0     | 0 | 0                          | 0    | 0     | 0 | 1     | 38            |
| 11:15 AM                        | 0                          | 1    | 0     | 0 | 1                          | 0    | 0     | 0 | 0                          | 0    | 1     | 0 | 0                          | 0    | 2     | 1 | 6     | 42            |
| 11:20 AM                        | 0                          | 1    | 0     | 0 | 0                          | 0    | 0     | 0 | 0                          | 0    | 1     | 0 | 0                          | 0    | 0     | 0 | 2     | 41            |
| 11:25 AM                        | 0                          | 0    | 0     | 0 | 0                          | 0    | 0     | 0 | 0                          | 0    | 0     | 0 | 0                          | 0    | 0     | 0 | 0     | 40            |
| 11:30 AM                        | 0                          | 1    | 0     | 0 | 0                          | 0    | 2     | 0 | 0                          | 1    | 0     | 0 | 0                          | 0    | 0     | 2 | 6     | 45            |
| 11:35 AM                        | 0                          | 2    | 0     | 0 | 0                          | 1    | 0     | 0 | 0                          | 0    | 2     | 0 | 0                          | 0    | 0     | 0 | 5     | 43            |
| 11:40 AM                        | 0                          | 2    | 0     | 0 | 0                          | 0    | 0     | 0 | 0                          | 0    | 1     | 0 | 0                          | 0    | 1     | 0 | 4     | 45            |
| 11:45 AM                        | 0                          | 0    | 0     | 0 | 1                          | 0    | 0     | 0 | 0                          | 0    | 0     | 0 | 0                          | 1    | 0     | 0 | 2     | 40            |
| 11:50 AM                        | 0                          | 1    | 0     | 0 | 0                          | 0    | 0     | 0 | 0                          | 0    | 2     | 0 | 0                          | 0    | 0     | 1 | 4     | 41            |
| 11:55 AM                        | 0                          | 0    | 1     | 0 | 0                          | 0    | 0     | 0 | 0                          | 1    | 0     | 0 | 0                          | 0    | 0     | 2 | 4     | 42            |
| 12:00 PM                        | 0                          | 0    | 0     | 0 | 0                          | 1    | 0     | 0 | 0                          | 0    | 1     | 0 | 0                          | 0    | 1     | 0 | 3     | 42            |
| 12:05 PM                        | 0                          | 1    | 1     | 0 | 0                          | 1    | 0     | 0 | 0                          | 0    | 0     | 0 | 0                          | 0    | 0     | 0 | 3     | 40            |
| 12:10 PM                        | 0                          | 1    | 0     | 0 | 0                          | 0    | 0     | 0 | 0                          | 0    | 1     | 0 | 0                          | 0    | 1     | 0 | 3     | 42            |
| 12:15 PM                        | 0                          | 0    | 0     | 0 | 0                          | 0    | 0     | 0 | 0                          | 2    | 1     | 0 | 0                          | 0    | 1     | 0 | 4     | 40            |
| 12:20 PM                        | 0                          | 0    | 0     | 0 | 0                          | 1    | 0     | 0 | 0                          | 0    | 1     | 0 | 0                          | 0    | 1     | 1 | 4     | 42            |
| 12:25 PM                        | 0                          | 1    | 0     | 0 | 0                          | 0    | 0     | 0 | 0                          | 0    | 0     | 0 | 0                          | 0    | 0     | 0 | 1     | 43            |
| 12:30 PM                        | 0                          | 0    | 0     | 0 | 0                          | 0    | 0     | 0 | 0                          | 0    | 1     | 1 | 0                          | 0    | 2     | 0 | 4     | 41            |
| 12:35 PM                        | 0                          | 0    | 0     | 0 | 0                          | 1    | 1     | 0 | 0                          | 1    | 0     | 1 | 0                          | 0    | 1     | 0 | 5     | 41            |
| 12:40 PM                        | 0                          | 1    | 0     | 0 | 0                          | 0    | 0     | 0 | 0                          | 0    | 0     | 0 | 0                          | 0    | 1     | 0 | 2     | 39            |
| 12:45 PM                        | 0                          | 1    | 0     | 0 | 1                          | 0    | 0     | 0 | 0                          | 0    | 2     | 0 | 0                          | 0    | 1     | 0 | 5     | 42            |
| 12:50 PM                        | 0                          | 0    | 0     | 0 | 0                          | 1    | 0     | 0 | 0                          | 0    | 0     | 0 | 0                          | 0    | 2     | 0 | 3     | 41            |
| 12:55 PM                        | 1                          | 1    | 0     | 0 | 0                          | 0    | 0     | 0 | 0                          | 0    | 0     | 0 | 0                          | 1    | 0     | 1 | 4     | 41            |
| 1:00 PM                         | 0                          | 0    | 0     | 0 | 0                          | 0    | 0     | 0 | 0                          | 0    | 0     | 0 | 0                          | 0    | 2     | 0 | 2     | 40            |
| 1:05 PM                         | 0                          | 0    | 0     | 0 | 0                          | 0    | 0     | 0 | 0                          | 0    | 1     | 0 | 0                          | 0    | 0     | 0 | 1     | 38            |
| 1:10 PM                         | 0                          | 0    | 0     | 0 | 1                          | 0    | 0     | 0 | 0                          | 0    | 0     | 0 | 0                          | 0    | 1     | 1 | 3     | 38            |
| 1:15 PM                         | 0                          | 0    | 0     | 0 | 0                          | 0    | 1     | 0 | 0                          | 0    | 2     | 0 | 0                          | 0    | 2     | 0 | 5     | 39            |
| 1:20 PM                         | 0                          | 0    | 0     | 0 | 0                          | 0    | 0     | 0 | 0                          | 0    | 2     | 1 | 0                          | 0    | 1     | 0 | 4     | 39            |
| 1:25 PM                         | 0                          | 1    | 0     | 0 | 1                          | 1    | 0     | 0 | 0                          | 0    | 4     | 0 | 0                          | 1    | 1     | 0 | 9     | 47            |
| 1:30 PM                         | 0                          | 2    | 0     | 0 | 0                          | 2    | 0     | 0 | 0                          | 1    | 2     | 1 | 0                          | 1    | 1     | 0 | 10    | 53            |
| 1:35 PM                         | 0                          | 4    | 0     | 0 | 0                          | 0    | 0     | 0 | 0                          | 1    | 1     | 0 | 0                          | 0    | 7     | 0 | 13    | 61            |
| 1:40 PM                         | 0                          | 0    | 0     | 0 | 0                          | 0    | 0     | 0 | 0                          | 0    | 1     | 0 | 0                          | 0    | 0     | 0 | 1     | 60            |
| 1:45 PM                         | 0                          | 0    | 0     | 0 | 0                          | 0    | 0     | 0 | 0                          | 0    | 1     | 0 | 0                          | 1    | 2     | 0 | 4     | 59            |
| 1:50 PM                         | 0                          | 0    | 0     | 0 | 0                          | 0    | 0     | 0 | 0                          | 0    | 1     | 1 | 0                          | 0    | 2     | 0 | 4     | 60            |
| 1:55 PM                         | 0                          | 0    | 0     | 0 | 1                          | 0    | 0     | 0 | 0                          | 0    | 1     | 0 | 0                          | 0    | 3     | 0 | 5     | 61            |
| 2:00 PM                         | 0                          | 0    | 1     | 0 | 0                          | 0    | 0     | 0 | 0                          | 0    | 0     | 1 | 0                          | 0    | 2     | 0 | 4     | 63            |
| 2:05 PM                         | 0                          | 0    | 0     | 0 | 0                          | 0    | 0     | 0 | 0                          | 1    | 3     | 0 | 0                          | 0    | 4     | 0 | 8     | 70            |
| 2:10 PM                         | 0                          | 2    | 1     | 0 | 0                          | 0    | 0     | 0 | 0                          | 0    | 0     | 0 | 0                          | 0    | 3     | 1 | 7     | 74            |
| 2:15 PM                         | 0                          | 1    | 0     | 0 | 0                          | 0    | 1     | 0 | 0                          | 0    | 1     | 0 | 0                          | 0    | 2     | 0 | 5     | 74            |
| 2:20 PM                         | 0                          | 0    | 0     | 0 | 1                          | 1    | 1     | 0 | 0                          | 0    | 2     | 1 | 0                          | 0    | 0     | 2 | 8     | 78            |
| 2:25 PM                         | 0                          | 2    | 0     | 0 | 0                          | 1    | 1     | 0 | 0                          | 0    | 1     | 0 | 0                          | 0    | 1     | 0 | 6     | 75            |
| 2:30 PM                         | 0                          | 0    | 0     | 0 | 0                          | 0    | 2     | 0 | 0                          | 0    | 1     | 0 | 0                          | 0    | 2     | 1 | 6     | 71            |
| 2:35 PM                         | 0                          | 0    | 0     | 0 | 0                          | 1    | 2     | 0 | 0                          | 0    | 1     | 0 | 0                          | 1    | 1     | 2 | 8     | 66            |
| 2:40 PM                         | 0                          | 1    | 0     | 0 | 1                          | 1    | 0     | 0 | 0                          | 0    | 1     | 0 | 0                          | 0    | 2     | 2 | 8     | 73            |
| 2:45 PM                         | 0                          | 3    | 0     | 0 | 0                          | 2    | 0     | 0 | 0                          | 1    | 1     | 0 | 0                          | 2    | 1     | 0 | 10    | 79            |
| 2:50 PM                         | 0                          | 1    | 1     | 0 | 0                          | 1    | 0     | 0 | 0                          | 0    | 1     | 0 | 0                          | 0    | 3     | 1 | 8     | 83            |
| 2:55 PM                         | 0                          | 1    | 0     | 0 | 0                          | 0    | 0     | 0 | 0                          | 0    | 1     | 0 | 0                          | 0    | 5     | 0 | 7     | 85            |
| 3:00 PM                         | 0                          | 2    | 0     | 0 | 1                          | 0    | 0     | 0 | 0                          | 0    | 0     | 0 | 0                          | 0    | 0     | 0 | 3     | 84            |
| 3:05 PM                         | 0                          | 0    | 0     | 0 | 0                          | 0    | 1     | 0 | 0                          | 1    | 1     | 0 | 0                          | 0    | 2     | 1 | 6     | 82            |
| 3:10 PM                         | 0                          | 0    | 0     | 0 | 0                          | 1    | 0     | 0 | 0                          | 0    | 1     | 0 | 0                          | 0    | 1     | 0 | 3     | 78            |
| 3:15 PM                         | 0                          | 1    | 0     | 0 | 1                          | 0    | 0     | 0 | 0                          | 0    | 0     | 0 | 0                          | 0    | 3     | 0 | 5     | 78            |
| 3:20 PM                         | 0                          | 0    | 0     | 0 | 0                          | 0    | 0     | 0 | 0                          | 0    | 2     | 0 | 0                          | 0    | 0     | 0 | 2     | 72            |
| 3:25 PM                         | 0                          | 0    | 0     | 0 | 0                          | 1    | 0     | 0 | 0                          | 0    | 2     | 0 | 0                          | 0    | 2     | 0 | 5     | 71            |
| 3:30 PM                         | 0                          | 0    | 0     | 0 | 0                          | 2    | 0     | 0 | 0                          | 0    | 0     | 0 | 0                          | 0    | 4     | 0 | 6     | 71            |
| 3:35 PM                         | 0                          | 0    | 0     | 0 | 0                          | 0    | 0     | 0 | 0                          | 0    | 0     | 0 | 0                          | 0    | 2     | 0 | 2     | 65            |
| 3:40 PM                         | 0                          | 0    | 0     | 0 | 0                          | 1    | 0     | 0 | 0                          | 0    | 0     | 0 | 0                          | 0    | 0     | 1 | 2     | 59            |
| 3:45 PM                         | 0                          | 0    | 0     | 0 | 0                          | 0    | 0     | 0 | 0                          | 1    | 0     | 1 | 0                          | 0    | 3     | 0 | 5     | 54            |
| 3:50 PM                         | 1                          | 0    | 0     | 0 | 1                          | 2    | 0     | 0 | 0                          | 0    | 3     | 0 | 0                          | 0    | 2     | 1 | 10    | 56            |
| 3:55 PM                         | 0                          | 0    | 0     | 0 | 1                          | 1    | 0     | 0 | 0                          | 0    | 1     | 0 | 0                          | 1    | 0     | 0 | 4     | 53            |
| 4:00 PM                         | 0                          | 0    | 1     | 0 | 2                          | 2    | 0     | 0 | 0                          | 2    | 1     | 0 | 0                          | 0    | 0     | 0 | 8     | 58            |
| 4:05 PM                         | 0                          | 0    | 0     | 0 | 0                          | 1    | 0     | 0 | 0                          | 0    | 1     | 0 | 0                          | 0    | 0     | 0 | 2     | 54            |
| 4:10 PM                         | 0                          | 0    | 0     | 0 | 1                          | 1    | 0     | 0 | 0                          | 2    | 1     | 0 | 0                          | 0    | 2     | 0 | 7     | 58            |
| 4:15 PM                         | 0                          | 0    | 0     | 0 | 0                          | 1    | 0     | 0 | 0                          | 0    | 0     | 0 | 0                          | 0    | 1     | 1 | 3     | 56            |
| 4:20 PM                         | 0                          | 1    | 1     | 0 | 0                          | 0    | 0     | 0 | 0                          | 0    | 1     | 1 | 0                          | 0    | 3     | 0 | 7     | 61            |
| 4:25 PM                         | 0                          | 0    | 1     | 0 | 1                          | 2    | 0     | 0 | 0                          | 0    | 2     | 1 | 0                          | 0    | 3     | 3 | 13    | 69            |
| 4:30 PM                         | 0                          | 1    | 1     | 0 | 0                          | 0    | 0     | 0 | 0                          | 0    | 0     | 0 | 0                          | 1    | 0     | 0 | 3     | 66            |

**Attachment B**

| 5-Min Count Period Beginning At | Kensington Rd (Northbound) |      |       |   | Kensington Rd (Southbound) |      |       |   | Shakespeare Dr (Eastbound) |      |       |   | Shakespeare Dr (Westbound) |      |       |   | Total | Hourly Totals |
|---------------------------------|----------------------------|------|-------|---|----------------------------|------|-------|---|----------------------------|------|-------|---|----------------------------|------|-------|---|-------|---------------|
|                                 | Left                       | Thru | Right | U | Left                       | Thru | Right | U | Left                       | Thru | Right | U | Left                       | Thru | Right | U |       |               |
| 4:35 PM                         | 0                          | 0    | 0     | 0 | 0                          | 1    | 1     | 0 | 1                          | 0    | 1     | 0 | 0                          | 0    | 0     | 0 | 4     | 68            |
| 4:40 PM                         | 0                          | 1    | 1     | 0 | 0                          | 2    | 0     | 0 | 0                          | 0    | 0     | 0 | 1                          | 1    | 1     | 0 | 7     | 73            |
| 4:45 PM                         | 0                          | 0    | 1     | 0 | 0                          | 2    | 0     | 0 | 1                          | 3    | 0     | 0 | 1                          | 0    | 0     | 0 | 8     | 76            |
| 4:50 PM                         | 0                          | 0    | 0     | 0 | 2                          | 0    | 0     | 0 | 1                          | 2    | 0     | 0 | 0                          | 0    | 0     | 0 | 5     | 71            |
| 4:55 PM                         | 0                          | 0    | 0     | 0 | 1                          | 1    | 0     | 0 | 0                          | 1    | 0     | 0 | 1                          | 1    | 0     | 0 | 5     | 72            |
| 5:00 PM                         | 0                          | 1    | 0     | 0 | 0                          | 0    | 0     | 0 | 0                          | 1    | 0     | 0 | 1                          | 3    | 0     | 0 | 6     | 70            |
| 5:05 PM                         | 0                          | 0    | 0     | 0 | 0                          | 0    | 0     | 0 | 0                          | 1    | 0     | 0 | 0                          | 2    | 0     | 0 | 3     | 71            |
| 5:10 PM                         | 0                          | 0    | 0     | 0 | 0                          | 2    | 0     | 0 | 0                          | 0    | 0     | 0 | 0                          | 1    | 1     | 0 | 4     | 68            |
| 5:15 PM                         | 0                          | 0    | 0     | 0 | 1                          | 0    | 0     | 0 | 0                          | 1    | 0     | 0 | 0                          | 1    | 0     | 0 | 3     | 68            |
| 5:20 PM                         | 0                          | 0    | 0     | 0 | 0                          | 0    | 0     | 0 | 0                          | 1    | 1     | 0 | 0                          | 1    | 0     | 0 | 3     | 64            |
| 5:25 PM                         | 0                          | 0    | 0     | 0 | 2                          | 1    | 0     | 0 | 0                          | 0    | 0     | 0 | 1                          | 1    | 0     | 0 | 5     | 56            |
| 5:30 PM                         | 0                          | 0    | 0     | 0 | 0                          | 0    | 0     | 0 | 0                          | 0    | 0     | 0 | 0                          | 1    | 0     | 0 | 1     | 54            |
| 5:35 PM                         | 0                          | 0    | 0     | 0 | 0                          | 3    | 0     | 0 | 0                          | 2    | 0     | 0 | 0                          | 3    | 0     | 0 | 8     | 58            |
| 5:40 PM                         | 0                          | 0    | 0     | 0 | 0                          | 0    | 0     | 0 | 0                          | 0    | 0     | 0 | 0                          | 1    | 1     | 0 | 2     | 53            |
| 5:45 PM                         | 0                          | 0    | 0     | 0 | 1                          | 0    | 0     | 0 | 0                          | 0    | 0     | 0 | 1                          | 1    | 1     | 0 | 4     | 49            |
| 5:50 PM                         | 0                          | 0    | 0     | 0 | 1                          | 3    | 0     | 0 | 0                          | 1    | 0     | 0 | 1                          | 1    | 0     | 0 | 7     | 51            |
| 5:55 PM                         | 0                          | 0    | 0     | 0 | 1                          | 0    | 0     | 0 | 0                          | 1    | 0     | 0 | 0                          | 1    | 0     | 0 | 3     | 49            |
| 6:00 PM                         | 0                          | 0    | 0     | 0 | 0                          | 0    | 0     | 0 | 0                          | 1    | 0     | 0 | 0                          | 1    | 1     | 0 | 3     | 46            |
| 6:05 PM                         | 0                          | 0    | 0     | 0 | 0                          | 1    | 0     | 0 | 1                          | 4    | 0     | 0 | 0                          | 0    | 0     | 0 | 6     | 49            |
| 6:10 PM                         | 0                          | 0    | 0     | 0 | 1                          | 1    | 0     | 0 | 0                          | 1    | 0     | 0 | 0                          | 1    | 0     | 0 | 4     | 49            |
| 6:15 PM                         | 0                          | 0    | 0     | 0 | 1                          | 1    | 0     | 0 | 0                          | 1    | 0     | 0 | 0                          | 0    | 0     | 0 | 3     | 49            |
| 6:20 PM                         | 0                          | 1    | 0     | 0 | 0                          | 0    | 1     | 0 | 0                          | 0    | 0     | 0 | 0                          | 1    | 0     | 0 | 3     | 49            |
| 6:25 PM                         | 0                          | 0    | 0     | 0 | 0                          | 0    | 0     | 0 | 0                          | 2    | 0     | 0 | 0                          | 3    | 0     | 0 | 5     | 49            |
| 6:30 PM                         | 0                          | 0    | 1     | 0 | 1                          | 2    | 0     | 0 | 0                          | 1    | 0     | 0 | 0                          | 1    | 0     | 0 | 6     | 54            |
| 6:35 PM                         | 0                          | 0    | 0     | 0 | 0                          | 0    | 0     | 0 | 1                          | 1    | 0     | 0 | 0                          | 1    | 0     | 0 | 3     | 49            |
| 6:40 PM                         | 0                          | 0    | 0     | 0 | 0                          | 0    | 0     | 0 | 1                          | 0    | 0     | 0 | 1                          | 0    | 0     | 0 | 2     | 49            |
| 6:45 PM                         | 0                          | 0    | 0     | 0 | 0                          | 2    | 0     | 0 | 0                          | 0    | 0     | 0 | 1                          | 1    | 2     | 0 | 6     | 51            |
| 6:50 PM                         | 0                          | 0    | 0     | 0 | 1                          | 0    | 0     | 0 | 0                          | 0    | 0     | 0 | 0                          | 0    | 0     | 0 | 1     | 45            |
| 6:55 PM                         | 0                          | 0    | 1     | 0 | 0                          | 0    | 0     | 0 | 0                          | 1    | 0     | 0 | 0                          | 0    | 0     | 0 | 2     | 44            |
| 7:00 PM                         | 0                          | 0    | 0     | 0 | 0                          | 0    | 1     | 0 | 0                          | 0    | 0     | 0 | 0                          | 1    | 0     | 0 | 2     | 43            |
| 7:05 PM                         | 0                          | 0    | 0     | 0 | 0                          | 1    | 0     | 0 | 0                          | 1    | 0     | 0 | 1                          | 0    | 0     | 0 | 3     | 40            |
| 7:10 PM                         | 0                          | 0    | 0     | 0 | 0                          | 1    | 0     | 0 | 0                          | 1    | 0     | 0 | 1                          | 0    | 1     | 0 | 4     | 40            |
| 7:15 PM                         | 0                          | 2    | 0     | 0 | 0                          | 0    | 0     | 0 | 0                          | 0    | 0     | 0 | 0                          | 2    | 0     | 0 | 4     | 41            |
| 7:20 PM                         | 0                          | 0    | 0     | 0 | 0                          | 0    | 0     | 0 | 0                          | 0    | 0     | 0 | 0                          | 2    | 0     | 0 | 2     | 40            |
| 7:25 PM                         | 0                          | 0    | 0     | 0 | 0                          | 1    | 0     | 0 | 0                          | 0    | 0     | 0 | 0                          | 2    | 0     | 0 | 3     | 38            |
| 7:30 PM                         | 0                          | 0    | 1     | 0 | 0                          | 0    | 0     | 0 | 0                          | 0    | 0     | 0 | 2                          | 2    | 0     | 0 | 5     | 37            |
| 7:35 PM                         | 0                          | 0    | 0     | 0 | 1                          | 1    | 0     | 0 | 1                          | 1    | 1     | 0 | 0                          | 0    | 0     | 0 | 5     | 39            |
| 7:40 PM                         | 0                          | 0    | 1     | 0 | 0                          | 0    | 1     | 0 | 0                          | 0    | 0     | 0 | 0                          | 1    | 1     | 0 | 4     | 41            |
| 7:45 PM                         | 0                          | 0    | 0     | 0 | 1                          | 0    | 1     | 0 | 0                          | 2    | 0     | 0 | 0                          | 0    | 0     | 0 | 4     | 39            |
| 7:50 PM                         | 0                          | 0    | 0     | 0 | 0                          | 0    | 0     | 0 | 0                          | 0    | 0     | 0 | 0                          | 1    | 0     | 0 | 1     | 39            |
| 7:55 PM                         | 0                          | 0    | 0     | 0 | 0                          | 0    | 0     | 0 | 0                          | 0    | 0     | 0 | 0                          | 0    | 0     | 0 | 0     | 37            |
| 8:00 PM                         | 0                          | 0    | 0     | 0 | 1                          | 0    | 0     | 0 | 0                          | 0    | 0     | 0 | 0                          | 2    | 0     | 0 | 3     | 38            |
| 8:05 PM                         | 0                          | 0    | 0     | 0 | 0                          | 0    | 0     | 0 | 0                          | 0    | 0     | 0 | 1                          | 0    | 0     | 0 | 1     | 36            |
| 8:10 PM                         | 0                          | 0    | 0     | 0 | 1                          | 0    | 0     | 0 | 0                          | 0    | 0     | 0 | 0                          | 0    | 0     | 0 | 1     | 33            |
| 8:15 PM                         | 0                          | 0    | 0     | 0 | 1                          | 0    | 0     | 0 | 0                          | 0    | 0     | 0 | 0                          | 0    | 0     | 0 | 1     | 30            |
| 8:20 PM                         | 0                          | 0    | 0     | 0 | 0                          | 1    | 0     | 0 | 0                          | 0    | 0     | 0 | 0                          | 0    | 0     | 0 | 1     | 29            |
| 8:25 PM                         | 0                          | 0    | 1     | 0 | 0                          | 0    | 0     | 0 | 1                          | 0    | 0     | 0 | 0                          | 0    | 0     | 0 | 2     | 28            |
| 8:30 PM                         | 0                          | 0    | 1     | 0 | 0                          | 0    | 0     | 0 | 0                          | 0    | 0     | 0 | 0                          | 0    | 0     | 0 | 1     | 24            |
| 8:35 PM                         | 0                          | 0    | 0     | 0 | 0                          | 1    | 0     | 0 | 0                          | 0    | 0     | 0 | 1                          | 1    | 1     | 0 | 4     | 23            |
| 8:40 PM                         | 0                          | 0    | 0     | 0 | 0                          | 1    | 0     | 0 | 0                          | 0    | 0     | 0 | 0                          | 0    | 0     | 0 | 1     | 20            |
| 8:45 PM                         | 0                          | 0    | 0     | 0 | 0                          | 0    | 0     | 0 | 0                          | 0    | 0     | 0 | 0                          | 1    | 0     | 0 | 1     | 17            |
| 8:50 PM                         | 0                          | 0    | 0     | 0 | 0                          | 1    | 0     | 0 | 0                          | 0    | 0     | 0 | 1                          | 1    | 0     | 0 | 3     | 19            |
| 8:55 PM                         | 0                          | 0    | 0     | 0 | 0                          | 0    | 0     | 0 | 0                          | 1    | 0     | 0 | 0                          | 1    | 0     | 0 | 2     | 21            |
| 9:00 PM                         | 0                          | 0    | 0     | 0 | 0                          | 0    | 0     | 0 | 0                          | 0    | 0     | 0 | 0                          | 0    | 1     | 0 | 1     | 19            |
| 9:05 PM                         | 0                          | 1    | 0     | 0 | 0                          | 0    | 0     | 0 | 0                          | 0    | 0     | 0 | 0                          | 1    | 0     | 0 | 2     | 20            |
| 9:10 PM                         | 0                          | 0    | 0     | 0 | 0                          | 0    | 0     | 0 | 0                          | 0    | 0     | 0 | 0                          | 0    | 1     | 0 | 1     | 20            |
| 9:15 PM                         | 0                          | 0    | 0     | 0 | 0                          | 0    | 0     | 0 | 0                          | 0    | 0     | 0 | 0                          | 0    | 1     | 0 | 1     | 20            |
| 9:20 PM                         | 0                          | 0    | 0     | 0 | 0                          | 0    | 0     | 0 | 0                          | 0    | 0     | 0 | 0                          | 0    | 0     | 0 | 0     | 19            |
| 9:25 PM                         | 0                          | 0    | 0     | 0 | 1                          | 0    | 0     | 0 | 1                          | 0    | 0     | 0 | 0                          | 2    | 1     | 0 | 5     | 22            |
| 9:30 PM                         | 0                          | 0    | 0     | 0 | 0                          | 0    | 0     | 0 | 0                          | 0    | 0     | 0 | 0                          | 0    | 0     | 0 | 0     | 21            |
| 9:35 PM                         | 0                          | 0    | 0     | 0 | 0                          | 0    | 0     | 0 | 0                          | 0    | 0     | 0 | 0                          | 1    | 0     | 0 | 1     | 18            |
| 9:40 PM                         | 0                          | 0    | 0     | 0 | 0                          | 0    | 0     | 0 | 0                          | 0    | 0     | 0 | 0                          | 0    | 0     | 0 | 0     | 17            |
| 9:45 PM                         | 0                          | 0    | 0     | 0 | 0                          | 1    | 0     | 0 | 0                          | 0    | 0     | 0 | 0                          | 0    | 0     | 0 | 1     | 17            |
| 9:50 PM                         | 0                          | 0    | 0     | 0 | 0                          | 0    | 0     | 0 | 0                          | 0    | 0     | 0 | 0                          | 0    | 0     | 0 | 0     | 14            |
| 9:55 PM                         | 0                          | 0    | 0     | 0 | 0                          | 1    | 0     | 0 | 0                          | 1    | 0     | 0 | 0                          | 1    | 0     | 0 | 3     | 15            |
| Peak 15-Min Flowrates           | Northbound                 |      |       |   | Southbound                 |      |       |   | Eastbound                  |      |       |   | Westbound                  |      |       |   | Total |               |
|                                 | Left                       | Thru | Right | U | Left                       | Thru | Right | U | Left                       | Thru | Right | U | Left                       | Thru | Right | U |       |               |
| All Vehicles                    | 0                          | 16   | 8     | 0 | 36                         | 16   | 4     | 0 | 12                         | 116  | 0     | 0 | 4                          | 16   | 12    | 0 | 240   |               |
| Heavy Trucks                    | 0                          | 4    | 0     |   | 0                          | 4    | 0     |   | 0                          | 0    | 0     |   | 0                          | 0    | 0     |   | 8     |               |
| Buses                           |                            |      |       |   |                            |      |       |   |                            |      |       |   |                            |      |       |   |       |               |
| Pedestrians                     |                            | 12   |       |   |                            | 8    |       |   |                            | 0    |       |   |                            | 8    |       |   | 28    |               |
| Bicycles                        | 0                          | 4    | 0     |   | 4                          | 4    | 0     |   | 0                          | 0    | 4     |   | 0                          | 0    | 0     |   | 16    |               |
| Scoters                         |                            |      |       |   |                            |      |       |   |                            |      |       |   |                            |      |       |   |       |               |
| <i>Comments:</i>                |                            |      |       |   |                            |      |       |   |                            |      |       |   |                            |      |       |   |       |               |

LOCATION: Kensington Rd -- Chesney Dr  
 CITY/STATE: Rossmore, CA

QC JOB #: 16966417  
 DATE: Wed, Apr 9 2025

Peak-Hour: 7:45 AM -- 8:45 AM  
 Peak 15-Min: 7:55 AM -- 8:10 AM

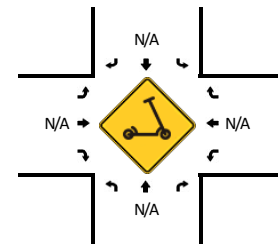
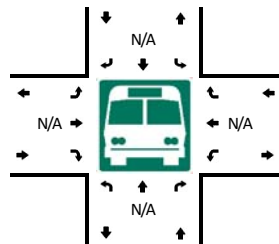
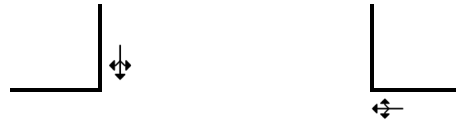
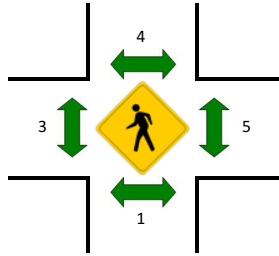
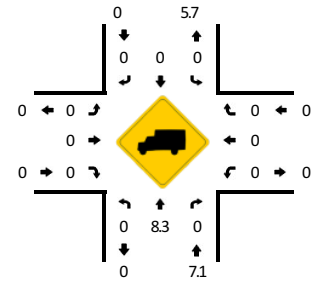
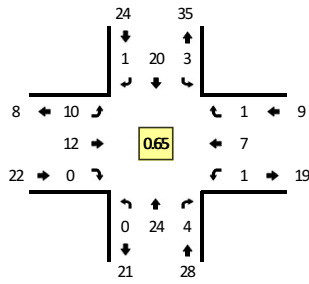

| 5-Min Count Period Beginning At | Kensington Rd (Northbound) |      |       |   | Kensington Rd (Southbound) |      |       |   | Chesney Dr (Eastbound) |      |       |   | Chesney Dr (Westbound) |      |       |   | Total | Hourly Totals |
|---------------------------------|----------------------------|------|-------|---|----------------------------|------|-------|---|------------------------|------|-------|---|------------------------|------|-------|---|-------|---------------|
|                                 | Left                       | Thru | Right | U | Left                       | Thru | Right | U | Left                   | Thru | Right | U | Left                   | Thru | Right | U |       |               |
| 6:00 AM                         | 0                          | 1    | 0     | 0 | 0                          | 0    | 0     | 0 | 0                      | 0    | 0     | 0 | 0                      | 0    | 0     | 0 | 1     |               |
| 6:05 AM                         | 0                          | 1    | 0     | 0 | 0                          | 1    | 0     | 0 | 0                      | 1    | 0     | 0 | 0                      | 0    | 0     | 0 | 3     |               |
| 6:10 AM                         | 0                          | 1    | 0     | 0 | 0                          | 0    | 0     | 0 | 0                      | 0    | 0     | 0 | 0                      | 0    | 0     | 0 | 1     |               |
| 6:15 AM                         | 0                          | 0    | 0     | 0 | 0                          | 1    | 0     | 0 | 0                      | 0    | 1     | 0 | 0                      | 0    | 0     | 0 | 2     |               |
| 6:20 AM                         | 0                          | 1    | 0     | 0 | 0                          | 0    | 0     | 0 | 0                      | 0    | 0     | 0 | 0                      | 0    | 0     | 0 | 1     |               |
| 6:25 AM                         | 0                          | 0    | 0     | 0 | 0                          | 0    | 0     | 0 | 0                      | 0    | 0     | 0 | 0                      | 0    | 0     | 0 | 0     |               |
| 6:30 AM                         | 0                          | 0    | 0     | 0 | 0                          | 0    | 0     | 0 | 0                      | 0    | 0     | 0 | 0                      | 0    | 0     | 0 | 0     |               |
| 6:35 AM                         | 0                          | 1    | 0     | 0 | 0                          | 0    | 0     | 0 | 0                      | 0    | 0     | 0 | 0                      | 0    | 1     | 0 | 2     |               |
| 6:40 AM                         | 0                          | 0    | 0     | 0 | 0                          | 0    | 0     | 0 | 0                      | 0    | 0     | 0 | 0                      | 0    | 0     | 0 | 0     |               |
| 6:45 AM                         | 0                          | 1    | 0     | 0 | 0                          | 0    | 0     | 0 | 0                      | 0    | 0     | 0 | 0                      | 0    | 0     | 0 | 1     |               |
| 6:50 AM                         | 0                          | 0    | 0     | 0 | 0                          | 0    | 0     | 0 | 0                      | 0    | 0     | 0 | 0                      | 0    | 0     | 0 | 0     |               |
| 6:55 AM                         | 0                          | 0    | 0     | 0 | 0                          | 1    | 0     | 0 | 0                      | 0    | 0     | 0 | 0                      | 1    | 0     | 0 | 2     | 13            |
| 7:00 AM                         | 0                          | 1    | 0     | 0 | 0                          | 0    | 1     | 0 | 0                      | 1    | 0     | 0 | 0                      | 0    | 0     | 0 | 3     | 15            |
| 7:05 AM                         | 0                          | 1    | 0     | 0 | 0                          | 0    | 0     | 0 | 0                      | 0    | 0     | 0 | 0                      | 0    | 0     | 0 | 1     | 13            |
| 7:10 AM                         | 0                          | 1    | 0     | 0 | 0                          | 0    | 0     | 0 | 0                      | 0    | 0     | 1 | 0                      | 0    | 0     | 0 | 2     | 14            |
| 7:15 AM                         | 0                          | 2    | 0     | 0 | 0                          | 0    | 0     | 0 | 0                      | 0    | 1     | 0 | 0                      | 0    | 0     | 0 | 3     | 15            |
| 7:20 AM                         | 0                          | 2    | 0     | 0 | 0                          | 0    | 0     | 0 | 0                      | 1    | 0     | 0 | 0                      | 0    | 0     | 0 | 3     | 17            |
| 7:25 AM                         | 0                          | 1    | 0     | 0 | 0                          | 0    | 1     | 0 | 0                      | 0    | 0     | 0 | 0                      | 0    | 0     | 0 | 2     | 19            |
| 7:30 AM                         | 0                          | 1    | 0     | 0 | 0                          | 1    | 0     | 0 | 0                      | 1    | 0     | 0 | 0                      | 0    | 0     | 0 | 3     | 22            |
| 7:35 AM                         | 0                          | 0    | 0     | 0 | 0                          | 1    | 0     | 0 | 0                      | 1    | 0     | 0 | 0                      | 0    | 0     | 0 | 2     | 22            |
| 7:40 AM                         | 0                          | 2    | 0     | 0 | 0                          | 1    | 0     | 0 | 0                      | 1    | 0     | 0 | 0                      | 0    | 0     | 0 | 4     | 26            |
| 7:45 AM                         | 0                          | 1    | 0     | 0 | 0                          | 3    | 0     | 0 | 0                      | 2    | 0     | 0 | 0                      | 1    | 1     | 0 | 8     | 33            |
| 7:50 AM                         | 0                          | 1    | 0     | 0 | 0                          | 4    | 0     | 0 | 0                      | 0    | 2     | 0 | 0                      | 0    | 1     | 0 | 8     | 41            |
| 7:55 AM                         | 0                          | 3    | 2     | 0 | 0                          | 4    | 0     | 0 | 0                      | 0    | 0     | 0 | 0                      | 0    | 2     | 0 | 11    | 50            |
| 8:00 AM                         | 0                          | 2    | 0     | 0 | 0                          | 2    | 0     | 0 | 0                      | 2    | 1     | 0 | 0                      | 0    | 2     | 0 | 9     | 56            |
| 8:05 AM                         | 0                          | 3    | 0     | 0 | 1                          | 0    | 0     | 0 | 0                      | 2    | 5     | 0 | 0                      | 0    | 0     | 1 | 12    | 67            |
| 8:10 AM                         | 0                          | 2    | 2     | 0 | 0                          | 1    | 0     | 0 | 0                      | 0    | 1     | 0 | 0                      | 0    | 0     | 0 | 6     | 71            |
| 8:15 AM                         | 0                          | 2    | 0     | 0 | 0                          | 0    | 0     | 0 | 0                      | 1    | 2     | 0 | 0                      | 0    | 0     | 0 | 5     | 73            |
| 8:20 AM                         | 0                          | 2    | 0     | 0 | 1                          | 1    | 0     | 0 | 0                      | 0    | 0     | 0 | 0                      | 0    | 0     | 0 | 4     | 74            |
| 8:25 AM                         | 0                          | 1    | 0     | 0 | 0                          | 2    | 0     | 0 | 0                      | 0    | 0     | 0 | 0                      | 1    | 0     | 0 | 4     | 76            |
| 8:30 AM                         | 0                          | 4    | 0     | 0 | 1                          | 0    | 0     | 0 | 0                      | 1    | 1     | 0 | 0                      | 0    | 0     | 0 | 7     | 80            |
| 8:35 AM                         | 0                          | 0    | 0     | 0 | 0                          | 1    | 0     | 0 | 0                      | 2    | 0     | 0 | 0                      | 0    | 0     | 0 | 3     | 81            |
| 8:40 AM                         | 0                          | 3    | 0     | 0 | 0                          | 2    | 1     | 0 | 0                      | 0    | 0     | 0 | 0                      | 0    | 0     | 0 | 6     | 83            |
| 8:45 AM                         | 0                          | 0    | 0     | 0 | 0                          | 0    | 2     | 0 | 0                      | 1    | 0     | 0 | 0                      | 0    | 0     | 0 | 3     | 78            |
| 8:50 AM                         | 0                          | 0    | 0     | 0 | 0                          | 2    | 0     | 0 | 0                      | 0    | 0     | 0 | 0                      | 0    | 1     | 0 | 3     | 73            |
| 8:55 AM                         | 0                          | 0    | 0     | 0 | 0                          | 1    | 0     | 0 | 0                      | 1    | 1     | 0 | 0                      | 0    | 1     | 0 | 4     | 66            |
| 9:00 AM                         | 0                          | 0    | 0     | 0 | 0                          | 0    | 0     | 0 | 0                      | 0    | 0     | 0 | 0                      | 0    | 0     | 0 | 0     | 57            |
| 9:05 AM                         | 0                          | 1    | 0     | 0 | 0                          | 0    | 0     | 0 | 0                      | 0    | 0     | 0 | 0                      | 0    | 0     | 0 | 1     | 46            |

Attachment B

| 5-Min Count Period Beginning At | Kensington Rd (Northbound) |      |       |   | Kensington Rd (Southbound) |      |       |   | Chesney Dr (Eastbound) |      |       |   | Chesney Dr (Westbound) |      |       |   | Total | Hourly Totals |
|---------------------------------|----------------------------|------|-------|---|----------------------------|------|-------|---|------------------------|------|-------|---|------------------------|------|-------|---|-------|---------------|
|                                 | Left                       | Thru | Right | U | Left                       | Thru | Right | U | Left                   | Thru | Right | U | Left                   | Thru | Right | U |       |               |
| 9:10 AM                         | 0                          | 0    | 0     | 0 | 0                          | 0    | 0     | 0 | 0                      | 1    | 0     | 0 | 0                      | 0    | 0     | 0 | 1     | 41            |
| 9:15 AM                         | 0                          | 1    | 0     | 0 | 0                          | 0    | 0     | 0 | 0                      | 0    | 1     | 0 | 0                      | 0    | 2     | 0 | 4     | 40            |
| 9:20 AM                         | 0                          | 1    | 0     | 0 | 0                          | 0    | 0     | 0 | 0                      | 0    | 0     | 0 | 0                      | 0    | 0     | 0 | 1     | 37            |
| 9:25 AM                         | 0                          | 1    | 0     | 0 | 0                          | 1    | 0     | 0 | 0                      | 0    | 0     | 0 | 0                      | 0    | 0     | 0 | 2     | 35            |
| 9:30 AM                         | 0                          | 1    | 0     | 0 | 0                          | 0    | 0     | 0 | 0                      | 1    | 0     | 0 | 0                      | 0    | 0     | 0 | 2     | 30            |
| 9:35 AM                         | 0                          | 0    | 0     | 0 | 0                          | 0    | 0     | 0 | 0                      | 0    | 0     | 0 | 0                      | 1    | 0     | 0 | 1     | 28            |
| 9:40 AM                         | 0                          | 1    | 0     | 0 | 0                          | 2    | 0     | 0 | 0                      | 0    | 0     | 0 | 0                      | 0    | 0     | 0 | 3     | 25            |
| 9:45 AM                         | 0                          | 1    | 0     | 0 | 0                          | 0    | 0     | 0 | 0                      | 0    | 0     | 0 | 0                      | 0    | 0     | 0 | 1     | 23            |
| 9:50 AM                         | 0                          | 0    | 0     | 0 | 0                          | 0    | 0     | 0 | 0                      | 0    | 0     | 0 | 0                      | 0    | 0     | 0 | 0     | 20            |
| 9:55 AM                         | 0                          | 1    | 0     | 0 | 0                          | 1    | 1     | 0 | 0                      | 0    | 0     | 0 | 0                      | 0    | 0     | 0 | 3     | 19            |
| 10:00 AM                        | 0                          | 4    | 0     | 0 | 0                          | 1    | 0     | 0 | 0                      | 0    | 0     | 1 | 0                      | 0    | 0     | 0 | 6     | 25            |
| 10:05 AM                        | 0                          | 0    | 0     | 0 | 0                          | 0    | 0     | 0 | 0                      | 0    | 0     | 0 | 0                      | 0    | 0     | 0 | 0     | 24            |
| 10:10 AM                        | 0                          | 0    | 0     | 0 | 0                          | 0    | 0     | 0 | 0                      | 0    | 0     | 0 | 0                      | 0    | 0     | 0 | 0     | 23            |
| 10:15 AM                        | 0                          | 1    | 1     | 0 | 1                          | 1    | 0     | 0 | 0                      | 1    | 1     | 0 | 0                      | 1    | 0     | 0 | 7     | 26            |
| 10:20 AM                        | 0                          | 0    | 0     | 0 | 0                          | 0    | 0     | 0 | 0                      | 0    | 0     | 0 | 0                      | 0    | 0     | 0 | 0     | 25            |
| 10:25 AM                        | 0                          | 1    | 0     | 0 | 0                          | 1    | 0     | 0 | 0                      | 0    | 1     | 0 | 0                      | 0    | 0     | 0 | 3     | 26            |
| 10:30 AM                        | 0                          | 0    | 0     | 0 | 0                          | 2    | 0     | 0 | 0                      | 1    | 1     | 0 | 0                      | 1    | 0     | 0 | 5     | 29            |
| 10:35 AM                        | 0                          | 1    | 1     | 0 | 0                          | 1    | 0     | 0 | 0                      | 0    | 0     | 0 | 0                      | 0    | 0     | 0 | 3     | 31            |
| 10:40 AM                        | 0                          | 0    | 0     | 0 | 0                          | 1    | 0     | 0 | 0                      | 0    | 0     | 0 | 0                      | 0    | 0     | 0 | 1     | 29            |
| 10:45 AM                        | 0                          | 3    | 0     | 0 | 0                          | 1    | 0     | 0 | 0                      | 0    | 0     | 0 | 0                      | 0    | 1     | 0 | 5     | 33            |
| 10:50 AM                        | 0                          | 3    | 0     | 0 | 0                          | 0    | 0     | 0 | 0                      | 0    | 0     | 0 | 0                      | 0    | 0     | 0 | 3     | 36            |
| 10:55 AM                        | 0                          | 1    | 0     | 0 | 1                          | 0    | 0     | 0 | 0                      | 0    | 0     | 0 | 0                      | 0    | 0     | 0 | 2     | 35            |
| 11:00 AM                        | 0                          | 2    | 0     | 0 | 0                          | 1    | 0     | 0 | 0                      | 0    | 0     | 0 | 0                      | 0    | 0     | 0 | 3     | 32            |
| 11:05 AM                        | 0                          | 1    | 0     | 0 | 0                          | 0    | 0     | 0 | 0                      | 0    | 1     | 0 | 0                      | 0    | 1     | 0 | 3     | 35            |
| 11:10 AM                        | 0                          | 0    | 0     | 0 | 0                          | 1    | 0     | 0 | 0                      | 0    | 0     | 0 | 0                      | 1    | 0     | 0 | 2     | 37            |
| 11:15 AM                        | 1                          | 2    | 0     | 0 | 0                          | 2    | 0     | 0 | 0                      | 1    | 0     | 0 | 0                      | 0    | 0     | 0 | 6     | 36            |
| 11:20 AM                        | 0                          | 1    | 0     | 0 | 0                          | 0    | 1     | 0 | 0                      | 0    | 0     | 0 | 0                      | 0    | 0     | 0 | 2     | 38            |
| 11:25 AM                        | 0                          | 0    | 0     | 0 | 0                          | 0    | 0     | 0 | 0                      | 0    | 0     | 0 | 0                      | 0    | 0     | 0 | 0     | 35            |
| 11:30 AM                        | 0                          | 2    | 0     | 0 | 0                          | 1    | 0     | 0 | 0                      | 0    | 0     | 0 | 0                      | 0    | 0     | 0 | 3     | 33            |
| 11:35 AM                        | 0                          | 1    | 1     | 0 | 0                          | 1    | 0     | 0 | 0                      | 0    | 0     | 1 | 0                      | 1    | 0     | 0 | 5     | 35            |
| 11:40 AM                        | 0                          | 2    | 0     | 0 | 0                          | 0    | 0     | 0 | 0                      | 0    | 1     | 0 | 0                      | 0    | 1     | 0 | 4     | 38            |
| 11:45 AM                        | 0                          | 0    | 0     | 0 | 0                          | 1    | 0     | 0 | 0                      | 0    | 0     | 0 | 0                      | 0    | 0     | 0 | 1     | 34            |
| 11:50 AM                        | 0                          | 1    | 0     | 0 | 0                          | 0    | 0     | 0 | 0                      | 0    | 0     | 0 | 0                      | 0    | 0     | 0 | 1     | 32            |
| 11:55 AM                        | 0                          | 0    | 1     | 0 | 1                          | 0    | 0     | 0 | 0                      | 0    | 0     | 0 | 0                      | 0    | 0     | 0 | 2     | 32            |
| 12:00 PM                        | 0                          | 1    | 0     | 0 | 0                          | 5    | 1     | 0 | 0                      | 1    | 0     | 0 | 0                      | 0    | 0     | 0 | 8     | 37            |
| 12:05 PM                        | 0                          | 0    | 0     | 0 | 1                          | 2    | 0     | 0 | 0                      | 0    | 0     | 0 | 0                      | 0    | 0     | 0 | 3     | 37            |
| 12:10 PM                        | 0                          | 2    | 0     | 0 | 0                          | 0    | 0     | 0 | 0                      | 0    | 0     | 0 | 0                      | 0    | 0     | 0 | 2     | 37            |
| 12:15 PM                        | 0                          | 2    | 0     | 0 | 0                          | 0    | 0     | 0 | 0                      | 1    | 1     | 0 | 0                      | 0    | 0     | 0 | 4     | 35            |
| 12:20 PM                        | 0                          | 1    | 0     | 0 | 1                          | 0    | 0     | 0 | 0                      | 1    | 0     | 0 | 0                      | 0    | 0     | 0 | 3     | 36            |
| 12:25 PM                        | 0                          | 1    | 0     | 0 | 0                          | 0    | 0     | 0 | 0                      | 0    | 0     | 0 | 0                      | 0    | 1     | 0 | 2     | 38            |
| 12:30 PM                        | 0                          | 0    | 0     | 0 | 0                          | 0    | 0     | 0 | 0                      | 0    | 0     | 0 | 0                      | 1    | 0     | 0 | 1     | 36            |
| 12:35 PM                        | 0                          | 2    | 0     | 0 | 1                          | 3    | 0     | 0 | 0                      | 0    | 0     | 0 | 0                      | 0    | 1     | 0 | 7     | 38            |
| 12:40 PM                        | 0                          | 1    | 0     | 0 | 0                          | 1    | 0     | 0 | 0                      | 1    | 1     | 0 | 0                      | 0    | 0     | 0 | 4     | 38            |
| 12:45 PM                        | 0                          | 1    | 0     | 0 | 0                          | 1    | 0     | 0 | 0                      | 0    | 0     | 0 | 0                      | 0    | 0     | 0 | 2     | 39            |
| 12:50 PM                        | 0                          | 1    | 0     | 0 | 1                          | 1    | 0     | 0 | 0                      | 0    | 0     | 0 | 0                      | 0    | 0     | 0 | 3     | 41            |
| 12:55 PM                        | 0                          | 0    | 0     | 0 | 0                          | 0    | 0     | 0 | 0                      | 0    | 2     | 0 | 0                      | 1    | 0     | 0 | 3     | 42            |
| 1:00 PM                         | 0                          | 1    | 0     | 0 | 0                          | 0    | 0     | 0 | 0                      | 0    | 0     | 0 | 0                      | 1    | 0     | 0 | 2     | 36            |
| 1:05 PM                         | 0                          | 1    | 0     | 0 | 0                          | 0    | 1     | 0 | 0                      | 0    | 0     | 0 | 0                      | 0    | 0     | 0 | 2     | 35            |
| 1:10 PM                         | 0                          | 1    | 0     | 0 | 0                          | 2    | 0     | 0 | 0                      | 0    | 0     | 0 | 0                      | 0    | 0     | 0 | 3     | 36            |
| 1:15 PM                         | 0                          | 0    | 0     | 0 | 0                          | 0    | 0     | 0 | 0                      | 0    | 0     | 0 | 1                      | 1    | 0     | 0 | 2     | 34            |
| 1:20 PM                         | 0                          | 0    | 1     | 0 | 0                          | 0    | 2     | 0 | 0                      | 2    | 1     | 0 | 0                      | 0    | 1     | 0 | 7     | 38            |
| 1:25 PM                         | 0                          | 1    | 0     | 0 | 0                          | 1    | 0     | 0 | 0                      | 1    | 1     | 0 | 0                      | 1    | 0     | 1 | 6     | 42            |
| 1:30 PM                         | 0                          | 1    | 0     | 0 | 0                          | 2    | 0     | 0 | 0                      | 1    | 0     | 0 | 0                      | 0    | 2     | 1 | 7     | 48            |
| 1:35 PM                         | 0                          | 4    | 2     | 0 | 0                          | 0    | 0     | 0 | 0                      | 0    | 0     | 0 | 0                      | 1    | 0     | 0 | 7     | 48            |
| 1:40 PM                         | 0                          | 0    | 0     | 0 | 0                          | 0    | 0     | 0 | 0                      | 0    | 1     | 0 | 0                      | 0    | 0     | 0 | 1     | 45            |
| 1:45 PM                         | 0                          | 0    | 0     | 0 | 0                          | 0    | 0     | 0 | 0                      | 0    | 0     | 0 | 0                      | 1    | 0     | 0 | 1     | 44            |
| 1:50 PM                         | 0                          | 0    | 0     | 0 | 0                          | 0    | 0     | 0 | 0                      | 0    | 0     | 0 | 0                      | 0    | 0     | 0 | 0     | 41            |
| 1:55 PM                         | 0                          | 1    | 0     | 0 | 0                          | 1    | 0     | 0 | 0                      | 0    | 0     | 0 | 0                      | 0    | 0     | 0 | 2     | 40            |
| 2:00 PM                         | 0                          | 0    | 0     | 0 | 0                          | 0    | 0     | 0 | 0                      | 0    | 0     | 0 | 0                      | 0    | 0     | 0 | 0     | 38            |
| 2:05 PM                         | 0                          | 2    | 0     | 0 | 1                          | 0    | 0     | 0 | 0                      | 0    | 0     | 0 | 0                      | 0    | 0     | 0 | 3     | 39            |
| 2:10 PM                         | 0                          | 4    | 0     | 0 | 0                          | 0    | 0     | 0 | 0                      | 0    | 0     | 0 | 0                      | 1    | 0     | 0 | 5     | 41            |
| 2:15 PM                         | 0                          | 1    | 0     | 0 | 0                          | 1    | 0     | 0 | 0                      | 2    | 0     | 0 | 0                      | 0    | 0     | 0 | 4     | 43            |
| 2:20 PM                         | 0                          | 0    | 0     | 0 | 0                          | 3    | 0     | 0 | 0                      | 0    | 0     | 0 | 0                      | 1    | 0     | 0 | 4     | 40            |
| 2:25 PM                         | 1                          | 3    | 0     | 0 | 0                          | 2    | 1     | 0 | 0                      | 0    | 1     | 0 | 0                      | 0    | 0     | 0 | 8     | 42            |
| 2:30 PM                         | 0                          | 2    | 0     | 0 | 0                          | 2    | 0     | 0 | 0                      | 0    | 0     | 0 | 0                      | 0    | 1     | 0 | 5     | 40            |
| 2:35 PM                         | 0                          | 1    | 0     | 0 | 0                          | 1    | 0     | 0 | 0                      | 1    | 1     | 1 | 0                      | 0    | 0     | 0 | 5     | 38            |
| 2:40 PM                         | 0                          | 4    | 1     | 0 | 0                          | 2    | 1     | 0 | 0                      | 1    | 0     | 0 | 0                      | 1    | 0     | 0 | 10    | 47            |
| 2:45 PM                         | 0                          | 3    | 1     | 0 | 0                          | 2    | 1     | 0 | 0                      | 0    | 0     | 0 | 0                      | 0    | 0     | 0 | 7     | 53            |
| 2:50 PM                         | 0                          | 3    | 0     | 0 | 0                          | 2    | 0     | 0 | 0                      | 0    | 0     | 0 | 0                      | 1    | 0     | 0 | 6     | 59            |
| 2:55 PM                         | 0                          | 1    | 0     | 0 | 1                          | 1    | 0     | 0 | 0                      | 0    | 0     | 0 | 0                      | 0    | 0     | 0 | 3     | 60            |
| 3:00 PM                         | 0                          | 2    | 0     | 0 | 0                          | 0    | 0     | 0 | 0                      | 0    | 0     | 0 | 0                      | 0    | 0     | 0 | 2     | 62            |
| 3:05 PM                         | 0                          | 1    | 0     | 0 | 0                          | 1    | 0     | 0 | 0                      | 1    | 0     | 0 | 0                      | 1    | 0     | 0 | 4     | 63            |
| 3:10 PM                         | 0                          | 0    | 0     | 0 | 0                          | 2    | 0     | 0 | 0                      | 1    | 0     | 0 | 0                      | 0    | 0     | 0 | 3     | 61            |
| 3:15 PM                         | 0                          | 1    | 0     | 0 | 0                          | 2    | 0     | 0 | 0                      | 1    | 0     | 0 | 0                      | 1    | 1     | 1 | 7     | 64            |
| 3:20 PM                         | 0                          | 1    | 0     | 0 | 0                          | 1    | 0     | 0 | 0                      | 0    | 0     | 0 | 0                      | 0    | 0     | 0 | 2     | 62            |
| 3:25 PM                         | 0                          | 0    | 0     | 0 | 0                          | 0    | 0     | 0 | 0                      | 0    | 1     | 0 | 0                      | 0    | 0     | 0 | 1     | 55            |
| 3:30 PM                         | 0                          | 0    | 0     | 0 | 0                          | 3    | 0     | 0 | 0                      | 0    | 0     | 0 | 0                      | 0    | 0     | 0 | 3     | 53            |
| 3:35 PM                         | 0                          | 0    | 0     | 0 | 0                          | 2    | 0     | 0 | 0                      | 1    | 1     | 0 | 0                      | 0    | 0     | 0 | 4     | 52            |
| 3:40 PM                         | 0                          | 1    | 0     | 0 | 0                          | 1    | 1     | 0 | 0                      | 0    | 2     | 0 | 0                      | 0    | 0     | 0 | 5     | 47            |
| 3:45 PM                         | 0                          | 1    | 1     | 0 | 0                          | 0    | 0     | 0 | 0                      | 0    | 0     | 0 | 0                      | 0    | 0     | 0 | 2     | 42            |
| 3:50 PM                         | 0                          | 0    | 0     | 0 | 0                          | 3    | 0     | 0 | 0                      | 1    | 0     | 0 | 0                      | 2    | 0     | 0 | 6     | 42            |
| 3:55 PM                         | 0                          | 0    | 0     | 0 | 0                          | 2    | 0     | 0 | 0                      | 0    | 1     | 0 | 0                      | 0    | 0     | 0 | 3     | 42            |
| 4:00 PM                         | 0                          | 1    | 0     | 0 | 0                          | 3    | 1     | 0 | 0                      | 0    | 0     | 0 | 0                      | 0    | 0     | 0 | 5     | 45            |
| 4:05 PM                         | 0                          | 1    | 1     | 0 | 0                          | 1    | 0     | 0 | 0                      | 1    | 0     | 0 | 0                      | 0    | 0     | 0 | 4     | 45            |
| 4:10 PM                         | 0                          | 2    | 0     | 0 | 0                          | 1    | 0     | 0 | 0                      | 0    | 0     | 0 | 0                      | 1    | 0     | 0 | 4     | 46            |
| 4:15 PM                         | 0                          | 1    | 0     | 0 | 0                          | 1    | 0     | 0 | 0                      | 0    | 1     | 0 | 0                      | 0    | 0     | 0 | 3     | 42            |
| 4:20 PM                         | 0                          | 2    | 0     | 0 | 0                          | 0    | 0     | 0 | 0                      | 0    | 0     | 0 | 0                      | 1    | 0     | 0 | 3     | 43            |
| 4:25 PM                         | 0                          | 3    | 0     | 0 | 0                          | 3    | 0     | 0 | 0                      | 0    | 0     | 0 | 0                      | 0    | 0     | 0 | 6     | 48            |
| 4:30 PM                         | 0                          | 1    | 0     | 0 | 1                          | 0    | 0     | 0 | 0                      | 0    | 2     | 0 | 0                      | 0    | 1     | 0 | 5     | 50            |

**Attachment B**

| 5-Min Count Period Beginning At | Kensington Rd (Northbound) |      |       |   | Kensington Rd (Southbound) |      |       |   | Chesney Dr (Eastbound) |      |       |   | Chesney Dr (Westbound) |      |       |   | Total | Hourly Totals |
|---------------------------------|----------------------------|------|-------|---|----------------------------|------|-------|---|------------------------|------|-------|---|------------------------|------|-------|---|-------|---------------|
|                                 | Left                       | Thru | Right | U | Left                       | Thru | Right | U | Left                   | Thru | Right | U | Left                   | Thru | Right | U |       |               |
| 4:35 PM                         | 0                          | 1    | 0     | 0 | 0                          | 2    | 0     | 0 | 1                      | 0    | 1     | 0 | 1                      | 0    | 0     | 0 | 6     | 52            |
| 4:40 PM                         | 0                          | 1    | 1     | 0 | 0                          | 2    | 1     | 0 | 0                      | 1    | 1     | 0 | 0                      | 0    | 0     | 0 | 6     | 53            |
| 4:45 PM                         | 0                          | 0    | 0     | 0 | 1                          | 2    | 0     | 0 | 1                      | 0    | 0     | 0 | 0                      | 1    | 0     | 0 | 5     | 56            |
| 4:50 PM                         | 0                          | 1    | 1     | 0 | 1                          | 1    | 0     | 0 | 1                      | 0    | 0     | 0 | 0                      | 1    | 0     | 0 | 6     | 56            |
| 4:55 PM                         | 0                          | 0    | 0     | 0 | 0                          | 2    | 0     | 0 | 0                      | 2    | 0     | 0 | 0                      | 0    | 0     | 0 | 4     | 57            |
| 5:00 PM                         | 0                          | 1    | 0     | 0 | 0                          | 1    | 0     | 0 | 0                      | 0    | 0     | 0 | 1                      | 0    | 1     | 0 | 4     | 56            |
| 5:05 PM                         | 0                          | 0    | 0     | 0 | 0                          | 2    | 0     | 0 | 1                      | 0    | 0     | 0 | 0                      | 0    | 0     | 0 | 3     | 55            |
| 5:10 PM                         | 0                          | 0    | 0     | 0 | 0                          | 1    | 0     | 0 | 0                      | 0    | 0     | 0 | 0                      | 0    | 0     | 0 | 1     | 52            |
| 5:15 PM                         | 0                          | 0    | 0     | 0 | 0                          | 1    | 0     | 0 | 0                      | 0    | 0     | 0 | 1                      | 0    | 0     | 0 | 2     | 51            |
| 5:20 PM                         | 0                          | 3    | 0     | 0 | 0                          | 0    | 0     | 0 | 0                      | 2    | 0     | 0 | 0                      | 0    | 0     | 0 | 5     | 53            |
| 5:25 PM                         | 0                          | 0    | 0     | 0 | 0                          | 4    | 0     | 0 | 1                      | 0    | 0     | 0 | 0                      | 0    | 0     | 0 | 5     | 52            |
| 5:30 PM                         | 0                          | 1    | 0     | 0 | 0                          | 0    | 0     | 0 | 0                      | 0    | 0     | 0 | 0                      | 1    | 0     | 0 | 2     | 49            |
| 5:35 PM                         | 0                          | 1    | 1     | 0 | 0                          | 3    | 1     | 0 | 0                      | 0    | 0     | 0 | 0                      | 1    | 0     | 0 | 7     | 50            |
| 5:40 PM                         | 0                          | 0    | 0     | 0 | 0                          | 0    | 0     | 0 | 0                      | 1    | 0     | 0 | 0                      | 0    | 0     | 0 | 1     | 45            |
| 5:45 PM                         | 0                          | 0    | 1     | 0 | 0                          | 1    | 0     | 0 | 0                      | 0    | 0     | 0 | 0                      | 0    | 0     | 0 | 2     | 42            |
| 5:50 PM                         | 0                          | 0    | 0     | 0 | 0                          | 5    | 0     | 0 | 1                      | 1    | 0     | 0 | 0                      | 0    | 0     | 0 | 7     | 43            |
| 5:55 PM                         | 0                          | 0    | 0     | 0 | 0                          | 2    | 0     | 0 | 0                      | 0    | 0     | 0 | 0                      | 0    | 0     | 0 | 2     | 41            |
| 6:00 PM                         | 0                          | 2    | 0     | 0 | 0                          | 1    | 0     | 0 | 0                      | 0    | 0     | 0 | 0                      | 1    | 0     | 0 | 4     | 41            |
| 6:05 PM                         | 0                          | 3    | 0     | 0 | 0                          | 3    | 0     | 0 | 1                      | 0    | 0     | 0 | 0                      | 0    | 1     | 0 | 8     | 46            |
| 6:10 PM                         | 0                          | 0    | 0     | 0 | 0                          | 3    | 0     | 0 | 0                      | 1    | 0     | 0 | 0                      | 0    | 0     | 0 | 4     | 49            |
| 6:15 PM                         | 0                          | 0    | 0     | 0 | 0                          | 2    | 0     | 0 | 0                      | 0    | 0     | 0 | 0                      | 2    | 0     | 0 | 4     | 51            |
| 6:20 PM                         | 0                          | 2    | 0     | 0 | 1                          | 1    | 0     | 0 | 0                      | 0    | 0     | 0 | 0                      | 1    | 1     | 0 | 6     | 52            |
| 6:25 PM                         | 0                          | 1    | 0     | 0 | 0                          | 1    | 0     | 0 | 0                      | 0    | 0     | 0 | 0                      | 0    | 0     | 0 | 2     | 49            |
| 6:30 PM                         | 0                          | 0    | 0     | 0 | 1                          | 3    | 0     | 0 | 1                      | 0    | 0     | 0 | 0                      | 0    | 0     | 0 | 5     | 52            |
| 6:35 PM                         | 0                          | 1    | 0     | 0 | 0                          | 1    | 0     | 0 | 0                      | 0    | 0     | 0 | 0                      | 1    | 0     | 0 | 3     | 48            |
| 6:40 PM                         | 0                          | 1    | 1     | 0 | 0                          | 0    | 1     | 0 | 0                      | 0    | 0     | 0 | 0                      | 0    | 2     | 0 | 5     | 52            |
| 6:45 PM                         | 0                          | 1    | 0     | 0 | 0                          | 2    | 0     | 0 | 0                      | 1    | 0     | 0 | 0                      | 0    | 0     | 0 | 4     | 54            |
| 6:50 PM                         | 0                          | 0    | 0     | 0 | 0                          | 1    | 0     | 0 | 0                      | 0    | 0     | 0 | 0                      | 0    | 0     | 0 | 1     | 48            |
| 6:55 PM                         | 0                          | 0    | 0     | 0 | 0                          | 0    | 1     | 0 | 0                      | 1    | 0     | 0 | 0                      | 0    | 0     | 0 | 2     | 48            |
| 7:00 PM                         | 0                          | 1    | 0     | 0 | 0                          | 1    | 0     | 0 | 0                      | 0    | 0     | 0 | 0                      | 1    | 0     | 0 | 3     | 47            |
| 7:05 PM                         | 0                          | 0    | 0     | 0 | 0                          | 2    | 0     | 0 | 2                      | 0    | 0     | 0 | 0                      | 0    | 0     | 0 | 4     | 43            |
| 7:10 PM                         | 0                          | 0    | 0     | 0 | 0                          | 1    | 0     | 0 | 2                      | 0    | 0     | 0 | 0                      | 1    | 0     | 0 | 4     | 43            |
| 7:15 PM                         | 0                          | 2    | 0     | 0 | 0                          | 2    | 1     | 0 | 0                      | 0    | 0     | 0 | 0                      | 0    | 0     | 0 | 5     | 44            |
| 7:20 PM                         | 0                          | 0    | 0     | 0 | 0                          | 0    | 0     | 0 | 0                      | 0    | 0     | 0 | 0                      | 0    | 0     | 0 | 0     | 38            |
| 7:25 PM                         | 0                          | 0    | 1     | 0 | 0                          | 1    | 0     | 0 | 0                      | 0    | 0     | 0 | 0                      | 0    | 0     | 0 | 2     | 38            |
| 7:30 PM                         | 0                          | 1    | 0     | 0 | 0                          | 0    | 0     | 0 | 0                      | 0    | 0     | 0 | 0                      | 0    | 0     | 0 | 1     | 34            |
| 7:35 PM                         | 0                          | 2    | 0     | 0 | 0                          | 2    | 0     | 0 | 0                      | 0    | 0     | 0 | 0                      | 0    | 0     | 0 | 4     | 35            |
| 7:40 PM                         | 0                          | 0    | 0     | 0 | 0                          | 1    | 0     | 0 | 0                      | 0    | 0     | 0 | 0                      | 0    | 0     | 0 | 1     | 31            |
| 7:45 PM                         | 0                          | 0    | 0     | 0 | 0                          | 2    | 0     | 0 | 0                      | 0    | 0     | 0 | 0                      | 0    | 1     | 0 | 3     | 30            |
| 7:50 PM                         | 0                          | 0    | 0     | 0 | 0                          | 1    | 0     | 0 | 0                      | 0    | 0     | 0 | 0                      | 0    | 0     | 0 | 1     | 30            |
| 7:55 PM                         | 0                          | 0    | 0     | 0 | 0                          | 0    | 0     | 0 | 0                      | 0    | 0     | 0 | 0                      | 0    | 0     | 0 | 0     | 28            |
| 8:00 PM                         | 0                          | 0    | 0     | 0 | 0                          | 1    | 0     | 0 | 0                      | 0    | 0     | 0 | 0                      | 0    | 0     | 0 | 1     | 26            |
| 8:05 PM                         | 0                          | 0    | 0     | 0 | 0                          | 0    | 0     | 0 | 0                      | 0    | 0     | 0 | 0                      | 0    | 0     | 0 | 0     | 22            |
| 8:10 PM                         | 0                          | 0    | 0     | 0 | 0                          | 1    | 0     | 0 | 0                      | 0    | 0     | 0 | 0                      | 0    | 0     | 0 | 1     | 19            |
| 8:15 PM                         | 0                          | 0    | 0     | 0 | 0                          | 0    | 0     | 0 | 0                      | 0    | 0     | 0 | 0                      | 1    | 0     | 0 | 1     | 15            |
| 8:20 PM                         | 0                          | 0    | 0     | 0 | 0                          | 3    | 0     | 0 | 0                      | 0    | 0     | 0 | 1                      | 0    | 0     | 0 | 4     | 19            |
| 8:25 PM                         | 0                          | 1    | 0     | 0 | 0                          | 0    | 0     | 0 | 0                      | 0    | 0     | 0 | 0                      | 0    | 0     | 0 | 1     | 18            |
| 8:30 PM                         | 0                          | 0    | 0     | 0 | 0                          | 1    | 0     | 0 | 0                      | 0    | 0     | 0 | 0                      | 0    | 0     | 0 | 1     | 18            |
| 8:35 PM                         | 0                          | 1    | 0     | 0 | 0                          | 3    | 0     | 0 | 0                      | 0    | 0     | 0 | 0                      | 0    | 0     | 0 | 4     | 18            |
| 8:40 PM                         | 0                          | 0    | 0     | 0 | 0                          | 0    | 0     | 0 | 0                      | 0    | 0     | 0 | 0                      | 0    | 0     | 0 | 0     | 17            |
| 8:45 PM                         | 0                          | 1    | 0     | 0 | 0                          | 0    | 0     | 0 | 0                      | 0    | 0     | 0 | 0                      | 0    | 0     | 0 | 1     | 15            |
| 8:50 PM                         | 0                          | 0    | 0     | 0 | 0                          | 1    | 0     | 0 | 1                      | 0    | 0     | 0 | 0                      | 1    | 1     | 0 | 4     | 18            |
| 8:55 PM                         | 0                          | 0    | 0     | 0 | 0                          | 0    | 0     | 0 | 0                      | 0    | 0     | 0 | 0                      | 0    | 0     | 0 | 0     | 18            |
| 9:00 PM                         | 0                          | 0    | 0     | 0 | 0                          | 0    | 0     | 0 | 0                      | 0    | 0     | 0 | 0                      | 0    | 0     | 0 | 0     | 17            |
| 9:05 PM                         | 0                          | 1    | 0     | 0 | 0                          | 0    | 0     | 0 | 0                      | 0    | 0     | 0 | 0                      | 0    | 0     | 0 | 1     | 18            |
| 9:10 PM                         | 0                          | 1    | 0     | 0 | 0                          | 0    | 0     | 0 | 0                      | 0    | 0     | 0 | 0                      | 0    | 0     | 0 | 1     | 18            |
| 9:15 PM                         | 0                          | 0    | 0     | 0 | 0                          | 1    | 0     | 0 | 0                      | 0    | 0     | 0 | 0                      | 1    | 0     | 0 | 2     | 19            |
| 9:20 PM                         | 0                          | 0    | 0     | 0 | 0                          | 1    | 0     | 0 | 0                      | 0    | 0     | 0 | 1                      | 0    | 0     | 0 | 2     | 17            |
| 9:25 PM                         | 1                          | 0    | 0     | 0 | 0                          | 0    | 0     | 0 | 0                      | 0    | 0     | 0 | 0                      | 0    | 0     | 0 | 1     | 17            |
| 9:30 PM                         | 0                          | 0    | 0     | 0 | 0                          | 0    | 0     | 0 | 0                      | 0    | 0     | 0 | 0                      | 0    | 0     | 0 | 0     | 16            |
| 9:35 PM                         | 0                          | 0    | 0     | 0 | 0                          | 0    | 0     | 0 | 0                      | 0    | 0     | 0 | 0                      | 0    | 0     | 0 | 0     | 12            |
| 9:40 PM                         | 0                          | 0    | 0     | 0 | 0                          | 0    | 0     | 0 | 0                      | 0    | 0     | 0 | 0                      | 0    | 0     | 0 | 0     | 12            |
| 9:45 PM                         | 0                          | 0    | 0     | 0 | 1                          | 1    | 0     | 0 | 0                      | 0    | 0     | 0 | 0                      | 0    | 0     | 0 | 2     | 13            |
| 9:50 PM                         | 0                          | 0    | 0     | 0 | 0                          | 0    | 0     | 0 | 0                      | 0    | 0     | 0 | 0                      | 0    | 0     | 0 | 0     | 9             |
| 9:55 PM                         | 0                          | 0    | 0     | 0 | 0                          | 1    | 0     | 0 | 0                      | 0    | 0     | 0 | 0                      | 0    | 0     | 0 | 1     | 10            |
| Peak 15-Min Flowrates           | Northbound                 |      |       |   | Southbound                 |      |       |   | Eastbound              |      |       |   | Westbound              |      |       |   | Total |               |
|                                 | Left                       | Thru | Right | U | Left                       | Thru | Right | U | Left                   | Thru | Right | U | Left                   | Thru | Right | U |       |               |
| All Vehicles                    | 0                          | 32   | 8     | 0 | 4                          | 24   | 0     | 0 | 16                     | 24   | 0     | 0 | 0                      | 16   | 4     | 0 | 128   |               |
| Heavy Trucks                    | 0                          | 4    | 0     | 0 | 0                          | 0    | 0     | 0 | 0                      | 0    | 0     | 0 | 0                      | 0    | 0     | 0 | 4     |               |
| Buses                           |                            |      |       |   |                            |      |       |   |                        |      |       |   |                        |      |       |   |       |               |
| Pedestrians                     |                            | 0    |       |   |                            | 4    |       |   |                        | 0    |       |   |                        | 0    |       |   | 4     |               |
| Bicycles                        | 0                          | 0    | 0     |   | 0                          | 0    | 0     |   | 0                      | 0    | 0     |   | 0                      | 0    | 0     |   | 0     |               |
| Scoters                         |                            |      |       |   |                            |      |       |   |                        |      |       |   |                        |      |       |   |       |               |
| <i>Comments:</i>                |                            |      |       |   |                            |      |       |   |                        |      |       |   |                        |      |       |   |       |               |

LOCATION: Wembley Rd -- Chesney Dr  
 CITY/STATE: Rossmore, CA

QC JOB #: 16966418  
 DATE: Wed, Apr 9 2025

Peak-Hour: 7:40 AM -- 8:40 AM  
 Peak 15-Min: 7:45 AM -- 8:00 AM

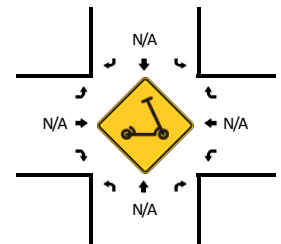
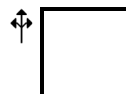
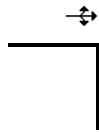
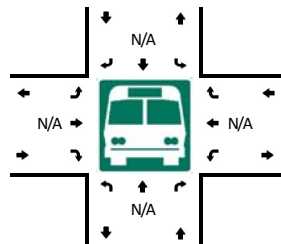
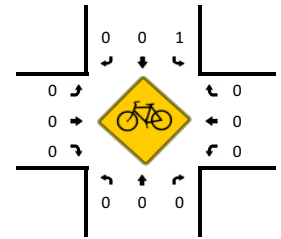
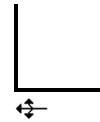
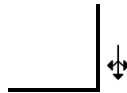
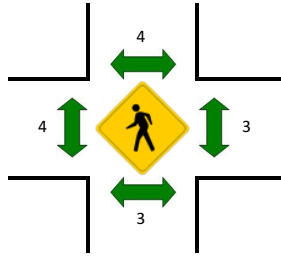
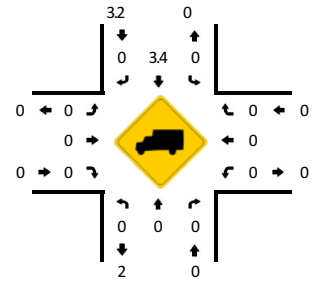
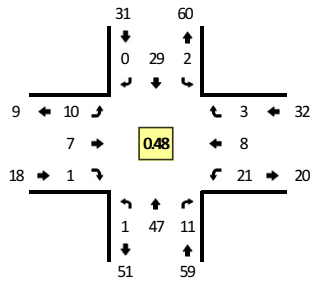

| 5-Min Count Period Beginning At | Wembley Rd (Northbound) |      |       |   | Wembley Rd (Southbound) |      |       |   | Chesney Dr (Eastbound) |      |       |   | Chesney Dr (Westbound) |      |       |   | Total | Hourly Totals |     |
|---------------------------------|-------------------------|------|-------|---|-------------------------|------|-------|---|------------------------|------|-------|---|------------------------|------|-------|---|-------|---------------|-----|
|                                 | Left                    | Thru | Right | U | Left                    | Thru | Right | U | Left                   | Thru | Right | U | Left                   | Thru | Right | U |       |               |     |
| 6:00 AM                         | 0                       | 0    | 0     | 0 | 0                       | 0    | 0     | 0 | 0                      | 0    | 0     | 0 | 0                      | 0    | 0     | 0 | 0     | 0             | 0   |
| 6:05 AM                         | 0                       | 2    | 0     | 0 | 0                       | 0    | 0     | 0 | 0                      | 0    | 0     | 0 | 0                      | 0    | 0     | 0 | 0     | 0             | 2   |
| 6:10 AM                         | 0                       | 0    | 1     | 0 | 0                       | 0    | 0     | 0 | 0                      | 0    | 0     | 0 | 0                      | 0    | 0     | 0 | 0     | 0             | 1   |
| 6:15 AM                         | 0                       | 0    | 0     | 0 | 0                       | 0    | 0     | 0 | 0                      | 0    | 0     | 1 | 0                      | 0    | 0     | 0 | 0     | 0             | 1   |
| 6:20 AM                         | 0                       | 0    | 0     | 0 | 0                       | 0    | 0     | 0 | 0                      | 0    | 0     | 0 | 0                      | 0    | 0     | 0 | 0     | 0             | 0   |
| 6:25 AM                         | 0                       | 0    | 0     | 0 | 0                       | 0    | 0     | 0 | 0                      | 0    | 0     | 0 | 0                      | 0    | 0     | 0 | 0     | 0             | 0   |
| 6:30 AM                         | 0                       | 0    | 0     | 0 | 0                       | 0    | 0     | 0 | 0                      | 0    | 0     | 0 | 0                      | 0    | 0     | 0 | 0     | 0             | 0   |
| 6:35 AM                         | 0                       | 1    | 0     | 0 | 0                       | 0    | 0     | 0 | 0                      | 0    | 0     | 0 | 0                      | 1    | 0     | 0 | 0     | 0             | 2   |
| 6:40 AM                         | 0                       | 0    | 0     | 0 | 0                       | 0    | 0     | 0 | 0                      | 0    | 0     | 0 | 0                      | 0    | 0     | 0 | 0     | 0             | 0   |
| 6:45 AM                         | 0                       | 2    | 1     | 0 | 0                       | 0    | 0     | 0 | 0                      | 0    | 0     | 0 | 0                      | 0    | 0     | 0 | 0     | 0             | 3   |
| 6:50 AM                         | 0                       | 0    | 1     | 0 | 0                       | 0    | 0     | 0 | 0                      | 0    | 0     | 0 | 0                      | 0    | 0     | 0 | 0     | 0             | 1   |
| 6:55 AM                         | 0                       | 0    | 0     | 0 | 0                       | 1    | 0     | 0 | 0                      | 0    | 0     | 0 | 0                      | 1    | 0     | 0 | 0     | 0             | 2   |
| 7:00 AM                         | 0                       | 1    | 0     | 0 | 0                       | 0    | 0     | 0 | 0                      | 0    | 0     | 0 | 0                      | 0    | 0     | 0 | 0     | 0             | 1   |
| 7:05 AM                         | 0                       | 0    | 0     | 0 | 0                       | 0    | 0     | 0 | 0                      | 0    | 0     | 0 | 0                      | 0    | 0     | 0 | 0     | 0             | 0   |
| 7:10 AM                         | 0                       | 0    | 0     | 0 | 0                       | 1    | 0     | 0 | 0                      | 0    | 0     | 0 | 0                      | 0    | 0     | 0 | 0     | 0             | 1   |
| 7:15 AM                         | 0                       | 1    | 0     | 0 | 0                       | 3    | 0     | 0 | 1                      | 0    | 0     | 0 | 0                      | 0    | 0     | 0 | 0     | 0             | 5   |
| 7:20 AM                         | 0                       | 0    | 0     | 0 | 0                       | 0    | 0     | 0 | 0                      | 0    | 0     | 0 | 0                      | 0    | 0     | 0 | 0     | 0             | 0   |
| 7:25 AM                         | 0                       | 0    | 0     | 0 | 0                       | 0    | 0     | 0 | 0                      | 0    | 0     | 0 | 0                      | 0    | 1     | 0 | 0     | 1             | 16  |
| 7:30 AM                         | 0                       | 0    | 0     | 0 | 0                       | 2    | 0     | 0 | 0                      | 0    | 0     | 0 | 0                      | 0    | 0     | 0 | 0     | 0             | 2   |
| 7:35 AM                         | 0                       | 0    | 0     | 0 | 0                       | 2    | 0     | 0 | 0                      | 0    | 0     | 0 | 0                      | 0    | 0     | 0 | 0     | 0             | 2   |
| 7:40 AM                         | 1                       | 4    | 0     | 0 | 0                       | 6    | 0     | 0 | 0                      | 0    | 0     | 0 | 4                      | 0    | 0     | 0 | 0     | 15            | 33  |
| 7:45 AM                         | 0                       | 7    | 2     | 0 | 0                       | 8    | 0     | 0 | 0                      | 0    | 0     | 0 | 6                      | 1    | 0     | 0 | 0     | 24            | 54  |
| 7:50 AM                         | 0                       | 11   | 2     | 0 | 0                       | 7    | 0     | 0 | 2                      | 0    | 0     | 0 | 5                      | 1    | 1     | 0 | 0     | 29            | 82  |
| 7:55 AM                         | 0                       | 6    | 3     | 0 | 0                       | 2    | 0     | 0 | 0                      | 2    | 0     | 0 | 5                      | 2    | 0     | 0 | 0     | 20            | 100 |
| 8:00 AM                         | 0                       | 7    | 1     | 0 | 0                       | 1    | 0     | 0 | 1                      | 0    | 0     | 0 | 1                      | 2    | 0     | 0 | 0     | 13            | 112 |
| 8:05 AM                         | 0                       | 6    | 1     | 0 | 0                       | 1    | 0     | 0 | 5                      | 1    | 0     | 0 | 0                      | 1    | 0     | 0 | 0     | 15            | 127 |
| 8:10 AM                         | 0                       | 2    | 0     | 0 | 0                       | 1    | 0     | 0 | 1                      | 1    | 0     | 0 | 0                      | 0    | 1     | 0 | 0     | 6             | 132 |
| 8:15 AM                         | 0                       | 1    | 0     | 0 | 0                       | 0    | 0     | 0 | 0                      | 2    | 0     | 0 | 0                      | 0    | 0     | 0 | 0     | 3             | 130 |
| 8:20 AM                         | 0                       | 1    | 0     | 0 | 1                       | 2    | 0     | 0 | 1                      | 0    | 0     | 0 | 0                      | 0    | 0     | 0 | 0     | 5             | 135 |
| 8:25 AM                         | 0                       | 0    | 0     | 0 | 0                       | 0    | 0     | 0 | 0                      | 0    | 0     | 0 | 0                      | 1    | 1     | 0 | 0     | 2             | 136 |
| 8:30 AM                         | 0                       | 1    | 1     | 0 | 0                       | 0    | 0     | 0 | 0                      | 1    | 0     | 0 | 0                      | 0    | 0     | 0 | 0     | 3             | 137 |
| 8:35 AM                         | 0                       | 1    | 1     | 0 | 1                       | 1    | 0     | 0 | 0                      | 0    | 1     | 0 | 0                      | 0    | 0     | 0 | 0     | 5             | 140 |
| 8:40 AM                         | 0                       | 0    | 0     | 0 | 0                       | 0    | 0     | 0 | 0                      | 0    | 0     | 0 | 0                      | 0    | 0     | 0 | 0     | 0             | 125 |
| 8:45 AM                         | 0                       | 0    | 0     | 0 | 0                       | 0    | 0     | 0 | 0                      | 0    | 0     | 0 | 0                      | 0    | 0     | 0 | 0     | 0             | 101 |
| 8:50 AM                         | 0                       | 1    | 0     | 0 | 0                       | 1    | 0     | 0 | 0                      | 0    | 0     | 0 | 0                      | 1    | 0     | 0 | 0     | 3             | 75  |
| 8:55 AM                         | 0                       | 3    | 0     | 0 | 0                       | 0    | 1     | 0 | 0                      | 1    | 0     | 0 | 0                      | 0    | 0     | 0 | 0     | 5             | 60  |
| 9:00 AM                         | 0                       | 0    | 0     | 0 | 1                       | 0    | 0     | 0 | 0                      | 0    | 0     | 0 | 0                      | 0    | 0     | 0 | 0     | 1             | 48  |
| 9:05 AM                         | 0                       | 2    | 0     | 0 | 0                       | 1    | 0     | 0 | 0                      | 0    | 0     | 0 | 0                      | 0    | 0     | 0 | 0     | 3             | 36  |



**Attachment B**

| 5-Min Count Period Beginning At | Wembley Rd (Northbound) |      |       |   | Wembley Rd (Southbound) |      |       |   | Chesney Dr (Eastbound) |      |       |   | Chesney Dr (Westbound) |      |       |   | Total | Hourly Totals |    |
|---------------------------------|-------------------------|------|-------|---|-------------------------|------|-------|---|------------------------|------|-------|---|------------------------|------|-------|---|-------|---------------|----|
|                                 | Left                    | Thru | Right | U | Left                    | Thru | Right | U | Left                   | Thru | Right | U | Left                   | Thru | Right | U |       |               |    |
| 4:35 PM                         | 0                       | 2    | 0     | 0 | 0                       | 0    | 0     | 0 | 0                      | 0    | 0     | 0 | 0                      | 1    | 0     | 0 | 0     | 3             | 50 |
| 4:40 PM                         | 0                       | 1    | 0     | 0 | 0                       | 0    | 1     | 0 | 0                      | 0    | 1     | 0 | 0                      | 1    | 0     | 0 | 0     | 4             | 51 |
| 4:45 PM                         | 0                       | 2    | 0     | 0 | 1                       | 0    | 0     | 0 | 0                      | 0    | 1     | 1 | 1                      | 1    | 1     | 0 | 0     | 7             | 51 |
| 4:50 PM                         | 0                       | 2    | 0     | 0 | 1                       | 1    | 1     | 0 | 0                      | 2    | 0     | 0 | 0                      | 0    | 0     | 0 | 0     | 7             | 54 |
| 4:55 PM                         | 0                       | 0    | 0     | 0 | 0                       | 1    | 0     | 0 | 0                      | 2    | 0     | 0 | 0                      | 0    | 1     | 0 | 0     | 4             | 54 |
| 5:00 PM                         | 0                       | 2    | 0     | 0 | 0                       | 1    | 0     | 0 | 0                      | 0    | 0     | 0 | 0                      | 2    | 0     | 0 | 0     | 5             | 57 |
| 5:05 PM                         | 0                       | 0    | 0     | 0 | 0                       | 0    | 0     | 0 | 0                      | 0    | 0     | 0 | 0                      | 0    | 0     | 0 | 0     | 0             | 55 |
| 5:10 PM                         | 0                       | 0    | 0     | 0 | 0                       | 1    | 0     | 0 | 0                      | 0    | 0     | 0 | 0                      | 0    | 1     | 0 | 0     | 2             | 51 |
| 5:15 PM                         | 0                       | 1    | 0     | 0 | 0                       | 0    | 0     | 0 | 0                      | 0    | 0     | 0 | 0                      | 1    | 0     | 0 | 0     | 2             | 51 |
| 5:20 PM                         | 0                       | 1    | 0     | 0 | 0                       | 0    | 0     | 0 | 1                      | 1    | 0     | 0 | 1                      | 0    | 0     | 0 | 0     | 4             | 51 |
| 5:25 PM                         | 0                       | 3    | 0     | 0 | 0                       | 0    | 0     | 0 | 0                      | 0    | 0     | 0 | 0                      | 0    | 1     | 0 | 0     | 4             | 54 |
| 5:30 PM                         | 0                       | 0    | 0     | 0 | 0                       | 1    | 1     | 0 | 0                      | 0    | 0     | 0 | 0                      | 0    | 0     | 0 | 0     | 2             | 44 |
| 5:35 PM                         | 0                       | 2    | 0     | 0 | 0                       | 2    | 0     | 0 | 0                      | 1    | 0     | 0 | 0                      | 1    | 0     | 0 | 0     | 6             | 47 |
| 5:40 PM                         | 0                       | 1    | 0     | 0 | 0                       | 0    | 0     | 0 | 1                      | 0    | 0     | 0 | 0                      | 0    | 0     | 0 | 0     | 2             | 45 |
| 5:45 PM                         | 0                       | 0    | 0     | 0 | 1                       | 1    | 0     | 0 | 0                      | 1    | 0     | 0 | 0                      | 0    | 0     | 0 | 0     | 3             | 41 |
| 5:50 PM                         | 0                       | 1    | 0     | 0 | 0                       | 0    | 0     | 0 | 0                      | 1    | 0     | 0 | 0                      | 0    | 0     | 0 | 0     | 2             | 36 |
| 5:55 PM                         | 0                       | 0    | 0     | 0 | 0                       | 1    | 0     | 0 | 0                      | 0    | 0     | 0 | 0                      | 0    | 0     | 0 | 0     | 1             | 33 |
| 6:00 PM                         | 0                       | 0    | 0     | 0 | 0                       | 1    | 0     | 0 | 0                      | 0    | 0     | 0 | 0                      | 1    | 0     | 0 | 0     | 2             | 30 |
| 6:05 PM                         | 0                       | 0    | 1     | 0 | 0                       | 0    | 0     | 0 | 0                      | 0    | 0     | 0 | 0                      | 1    | 0     | 0 | 0     | 2             | 32 |
| 6:10 PM                         | 0                       | 0    | 0     | 0 | 0                       | 0    | 0     | 0 | 0                      | 1    | 0     | 0 | 1                      | 0    | 0     | 0 | 0     | 2             | 32 |
| 6:15 PM                         | 0                       | 1    | 0     | 0 | 0                       | 0    | 0     | 0 | 0                      | 0    | 0     | 0 | 0                      | 2    | 1     | 0 | 0     | 4             | 34 |
| 6:20 PM                         | 0                       | 0    | 0     | 0 | 1                       | 1    | 0     | 0 | 0                      | 1    | 0     | 0 | 0                      | 2    | 0     | 0 | 0     | 5             | 35 |
| 6:25 PM                         | 0                       | 2    | 0     | 0 | 0                       | 0    | 0     | 0 | 0                      | 0    | 0     | 0 | 1                      | 0    | 0     | 0 | 0     | 3             | 34 |
| 6:30 PM                         | 0                       | 2    | 0     | 0 | 0                       | 1    | 0     | 0 | 0                      | 1    | 0     | 0 | 0                      | 0    | 0     | 0 | 0     | 4             | 36 |
| 6:35 PM                         | 0                       | 0    | 0     | 0 | 0                       | 2    | 0     | 0 | 0                      | 0    | 0     | 0 | 0                      | 1    | 0     | 0 | 0     | 3             | 33 |
| 6:40 PM                         | 0                       | 0    | 0     | 0 | 2                       | 0    | 0     | 0 | 0                      | 1    | 0     | 0 | 1                      | 2    | 0     | 0 | 0     | 6             | 37 |
| 6:45 PM                         | 0                       | 0    | 0     | 0 | 0                       | 1    | 0     | 0 | 0                      | 1    | 0     | 0 | 0                      | 0    | 0     | 0 | 0     | 2             | 36 |
| 6:50 PM                         | 0                       | 1    | 0     | 0 | 0                       | 0    | 0     | 0 | 0                      | 0    | 0     | 0 | 0                      | 0    | 0     | 0 | 0     | 1             | 35 |
| 6:55 PM                         | 0                       | 1    | 0     | 0 | 0                       | 1    | 0     | 0 | 0                      | 1    | 0     | 0 | 0                      | 0    | 0     | 0 | 0     | 3             | 37 |
| 7:00 PM                         | 0                       | 0    | 0     | 0 | 0                       | 0    | 0     | 0 | 0                      | 0    | 0     | 0 | 0                      | 1    | 0     | 0 | 0     | 1             | 36 |
| 7:05 PM                         | 0                       | 1    | 0     | 0 | 0                       | 0    | 0     | 0 | 0                      | 0    | 0     | 0 | 0                      | 0    | 1     | 0 | 0     | 2             | 36 |
| 7:10 PM                         | 0                       | 0    | 0     | 0 | 0                       | 0    | 0     | 0 | 0                      | 0    | 0     | 0 | 0                      | 1    | 0     | 0 | 0     | 1             | 35 |
| 7:15 PM                         | 0                       | 1    | 0     | 0 | 0                       | 1    | 0     | 0 | 0                      | 0    | 0     | 0 | 0                      | 0    | 0     | 0 | 0     | 2             | 33 |
| 7:20 PM                         | 0                       | 1    | 0     | 0 | 0                       | 1    | 0     | 0 | 0                      | 0    | 0     | 0 | 0                      | 0    | 0     | 0 | 0     | 2             | 30 |
| 7:25 PM                         | 0                       | 0    | 0     | 0 | 0                       | 0    | 0     | 0 | 0                      | 1    | 0     | 0 | 0                      | 0    | 0     | 0 | 0     | 1             | 28 |
| 7:30 PM                         | 0                       | 0    | 1     | 0 | 0                       | 0    | 0     | 0 | 0                      | 0    | 0     | 0 | 0                      | 0    | 0     | 0 | 0     | 1             | 25 |
| 7:35 PM                         | 0                       | 0    | 0     | 0 | 0                       | 0    | 0     | 0 | 0                      | 0    | 0     | 0 | 0                      | 0    | 0     | 0 | 0     | 0             | 22 |
| 7:40 PM                         | 0                       | 0    | 0     | 0 | 0                       | 0    | 0     | 0 | 0                      | 0    | 0     | 0 | 1                      | 0    | 0     | 0 | 0     | 1             | 17 |
| 7:45 PM                         | 1                       | 1    | 0     | 0 | 0                       | 0    | 0     | 0 | 0                      | 0    | 0     | 0 | 0                      | 0    | 1     | 0 | 0     | 3             | 18 |
| 7:50 PM                         | 0                       | 0    | 0     | 0 | 0                       | 0    | 0     | 0 | 0                      | 0    | 0     | 0 | 0                      | 0    | 0     | 0 | 0     | 0             | 17 |
| 7:55 PM                         | 0                       | 0    | 0     | 0 | 0                       | 0    | 0     | 0 | 0                      | 0    | 0     | 0 | 0                      | 0    | 0     | 0 | 0     | 0             | 14 |
| 8:00 PM                         | 0                       | 0    | 0     | 0 | 1                       | 1    | 0     | 0 | 0                      | 0    | 0     | 0 | 0                      | 0    | 0     | 0 | 0     | 2             | 15 |
| 8:05 PM                         | 0                       | 1    | 0     | 0 | 0                       | 0    | 0     | 0 | 0                      | 0    | 0     | 0 | 0                      | 0    | 0     | 0 | 0     | 1             | 14 |
| 8:10 PM                         | 0                       | 1    | 0     | 0 | 0                       | 0    | 0     | 0 | 0                      | 0    | 0     | 0 | 0                      | 0    | 0     | 0 | 0     | 1             | 14 |
| 8:15 PM                         | 0                       | 0    | 0     | 0 | 0                       | 0    | 0     | 0 | 0                      | 0    | 0     | 0 | 0                      | 1    | 1     | 0 | 0     | 2             | 14 |
| 8:20 PM                         | 1                       | 0    | 0     | 0 | 0                       | 0    | 0     | 0 | 0                      | 0    | 0     | 0 | 0                      | 0    | 0     | 0 | 0     | 1             | 13 |
| 8:25 PM                         | 0                       | 0    | 0     | 0 | 0                       | 0    | 0     | 0 | 0                      | 0    | 0     | 0 | 0                      | 0    | 0     | 0 | 0     | 0             | 12 |
| 8:30 PM                         | 0                       | 1    | 0     | 0 | 0                       | 1    | 0     | 0 | 0                      | 0    | 0     | 0 | 0                      | 0    | 0     | 0 | 0     | 2             | 13 |
| 8:35 PM                         | 0                       | 0    | 0     | 0 | 0                       | 1    | 0     | 0 | 0                      | 0    | 0     | 0 | 0                      | 0    | 0     | 0 | 0     | 1             | 14 |
| 8:40 PM                         | 0                       | 1    | 0     | 0 | 0                       | 0    | 0     | 0 | 0                      | 0    | 0     | 0 | 0                      | 0    | 0     | 0 | 0     | 1             | 14 |
| 8:45 PM                         | 0                       | 0    | 0     | 0 | 0                       | 0    | 0     | 0 | 0                      | 0    | 0     | 0 | 0                      | 0    | 0     | 0 | 0     | 0             | 11 |
| 8:50 PM                         | 1                       | 0    | 0     | 0 | 0                       | 1    | 0     | 0 | 0                      | 0    | 0     | 0 | 0                      | 1    | 0     | 0 | 0     | 3             | 14 |
| 8:55 PM                         | 0                       | 0    | 0     | 0 | 0                       | 1    | 0     | 0 | 0                      | 0    | 0     | 0 | 0                      | 0    | 0     | 0 | 0     | 1             | 15 |
| 9:00 PM                         | 0                       | 0    | 0     | 0 | 0                       | 0    | 0     | 0 | 0                      | 0    | 0     | 0 | 0                      | 0    | 0     | 0 | 0     | 0             | 13 |
| 9:05 PM                         | 0                       | 0    | 0     | 0 | 0                       | 0    | 0     | 0 | 0                      | 0    | 0     | 0 | 0                      | 0    | 0     | 0 | 0     | 0             | 12 |
| 9:10 PM                         | 0                       | 0    | 0     | 0 | 0                       | 1    | 0     | 0 | 0                      | 0    | 0     | 0 | 0                      | 0    | 0     | 0 | 0     | 1             | 12 |
| 9:15 PM                         | 0                       | 0    | 0     | 0 | 0                       | 0    | 0     | 0 | 0                      | 0    | 0     | 0 | 0                      | 1    | 0     | 0 | 0     | 1             | 11 |
| 9:20 PM                         | 0                       | 0    | 0     | 0 | 0                       | 0    | 0     | 0 | 0                      | 0    | 0     | 0 | 0                      | 1    | 0     | 0 | 0     | 1             | 11 |
| 9:25 PM                         | 0                       | 0    | 0     | 0 | 0                       | 0    | 0     | 0 | 0                      | 0    | 0     | 0 | 0                      | 0    | 0     | 0 | 0     | 0             | 11 |
| 9:30 PM                         | 0                       | 0    | 0     | 0 | 0                       | 1    | 0     | 0 | 0                      | 0    | 0     | 0 | 0                      | 0    | 0     | 0 | 0     | 1             | 10 |
| 9:35 PM                         | 0                       | 0    | 0     | 0 | 1                       | 0    | 0     | 0 | 0                      | 0    | 0     | 0 | 0                      | 0    | 0     | 0 | 0     | 1             | 10 |
| 9:40 PM                         | 0                       | 0    | 0     | 0 | 0                       | 0    | 0     | 0 | 0                      | 0    | 0     | 0 | 0                      | 0    | 0     | 0 | 0     | 0             | 9  |
| 9:45 PM                         | 0                       | 0    | 0     | 0 | 0                       | 0    | 0     | 0 | 0                      | 1    | 0     | 0 | 0                      | 0    | 0     | 0 | 0     | 1             | 10 |
| 9:50 PM                         | 0                       | 0    | 0     | 0 | 0                       | 0    | 0     | 0 | 0                      | 0    | 0     | 0 | 0                      | 0    | 0     | 0 | 0     | 0             | 7  |
| 9:55 PM                         | 0                       | 0    | 0     | 0 | 0                       | 0    | 0     | 0 | 0                      | 0    | 0     | 0 | 0                      | 0    | 0     | 0 | 0     | 0             | 6  |
| Peak 15-Min Flowrates           | Northbound              |      |       |   | Southbound              |      |       |   | Eastbound              |      |       |   | Westbound              |      |       |   | Total |               |    |
|                                 | Left                    | Thru | Right | U | Left                    | Thru | Right | U | Left                   | Thru | Right | U | Left                   | Thru | Right | U |       |               |    |
| All Vehicles                    | 0                       | 96   | 28    | 0 | 0                       | 68   | 0     | 0 | 8                      | 8    | 0     | 0 | 64                     | 16   | 4     | 0 | 292   |               |    |
| Heavy Trucks                    | 0                       | 0    | 0     | 0 | 0                       | 0    | 0     | 0 | 0                      | 0    | 0     | 0 | 0                      | 0    | 0     | 0 | 0     |               |    |
| Buses                           |                         |      |       |   |                         |      |       |   |                        |      |       |   |                        |      |       |   |       |               |    |
| Pedestrians                     |                         | 4    |       |   |                         | 0    |       |   |                        | 12   |       |   |                        | 0    |       |   | 16    |               |    |
| Bicycles                        | 0                       | 0    | 0     |   | 0                       | 0    | 0     |   | 0                      | 0    | 0     |   | 0                      | 0    | 0     |   | 0     |               |    |
| Scoters                         |                         |      |       |   |                         |      |       |   |                        |      |       |   |                        |      |       |   |       |               |    |
| <i>Comments:</i>                |                         |      |       |   |                         |      |       |   |                        |      |       |   |                        |      |       |   |       |               |    |

LOCATION: Loch Lomond Rd -- Chesney Dr  
 CITY/STATE: Rossmoor, CA

QC JOB #: 16966419  
 DATE: Wed, Apr 9 2025

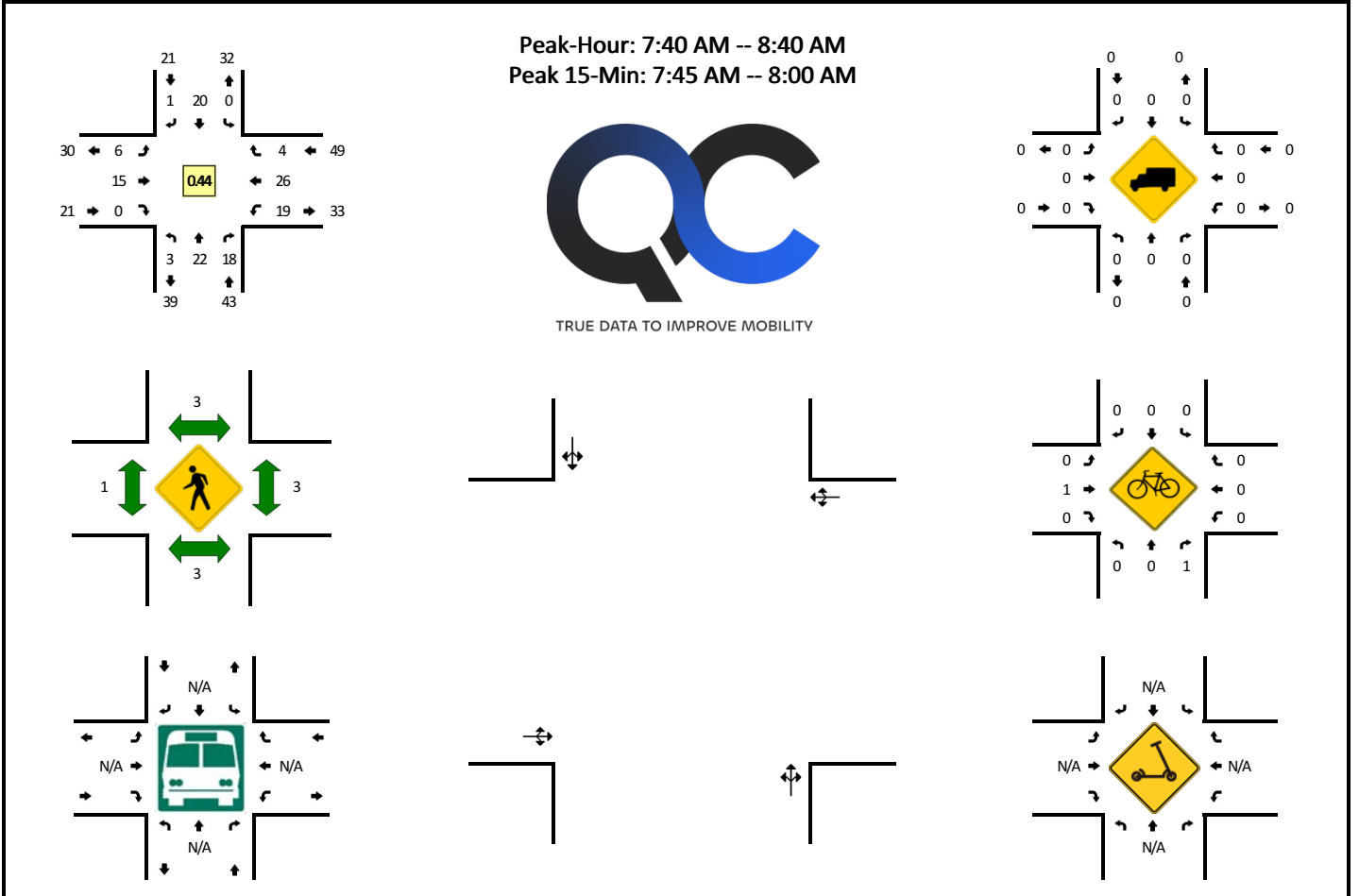

| 5-Min Count Period Beginning At | Loch Lomond Rd (Northbound) |      |       |   | Loch Lomond Rd (Southbound) |      |       |   | Chesney Dr (Eastbound) |      |       |   | Chesney Dr (Westbound) |      |       |   | Total | Hourly Totals |
|---------------------------------|-----------------------------|------|-------|---|-----------------------------|------|-------|---|------------------------|------|-------|---|------------------------|------|-------|---|-------|---------------|
|                                 | Left                        | Thru | Right | U | Left                        | Thru | Right | U | Left                   | Thru | Right | U | Left                   | Thru | Right | U |       |               |
| 6:00 AM                         | 0                           | 0    | 0     | 0 | 0                           | 0    | 0     | 0 | 0                      | 0    | 0     | 0 | 0                      | 0    | 0     | 0 | 0     | 0             |
| 6:05 AM                         | 0                           | 0    | 0     | 0 | 0                           | 1    | 0     | 0 | 0                      | 0    | 0     | 0 | 0                      | 0    | 0     | 0 | 0     | 1             |
| 6:10 AM                         | 0                           | 0    | 0     | 0 | 0                           | 0    | 0     | 0 | 0                      | 0    | 1     | 0 | 0                      | 0    | 0     | 0 | 0     | 1             |
| 6:15 AM                         | 0                           | 0    | 0     | 0 | 0                           | 0    | 0     | 0 | 0                      | 0    | 0     | 0 | 0                      | 0    | 0     | 0 | 0     | 0             |
| 6:20 AM                         | 0                           | 0    | 0     | 0 | 0                           | 0    | 0     | 0 | 0                      | 0    | 0     | 0 | 0                      | 0    | 0     | 0 | 0     | 0             |
| 6:25 AM                         | 0                           | 0    | 0     | 0 | 0                           | 0    | 0     | 0 | 0                      | 0    | 2     | 0 | 0                      | 0    | 0     | 0 | 0     | 2             |
| 6:30 AM                         | 0                           | 0    | 0     | 0 | 0                           | 0    | 1     | 0 | 0                      | 0    | 1     | 0 | 0                      | 0    | 0     | 0 | 0     | 2             |
| 6:35 AM                         | 0                           | 0    | 0     | 0 | 0                           | 0    | 0     | 0 | 0                      | 0    | 0     | 0 | 0                      | 0    | 2     | 0 | 0     | 2             |
| 6:40 AM                         | 0                           | 0    | 0     | 0 | 0                           | 0    | 0     | 0 | 0                      | 0    | 0     | 0 | 0                      | 0    | 0     | 0 | 0     | 0             |
| 6:45 AM                         | 0                           | 0    | 0     | 0 | 0                           | 0    | 0     | 0 | 0                      | 1    | 2     | 0 | 0                      | 0    | 0     | 0 | 0     | 3             |
| 6:50 AM                         | 0                           | 0    | 0     | 0 | 0                           | 0    | 0     | 0 | 0                      | 0    | 0     | 0 | 0                      | 0    | 0     | 0 | 0     | 0             |
| 6:55 AM                         | 0                           | 0    | 0     | 0 | 1                           | 0    | 0     | 0 | 0                      | 0    | 0     | 0 | 0                      | 0    | 1     | 0 | 0     | 2             |
| 7:00 AM                         | 0                           | 0    | 0     | 0 | 0                           | 0    | 0     | 0 | 0                      | 0    | 0     | 0 | 0                      | 1    | 0     | 0 | 0     | 1             |
| 7:05 AM                         | 0                           | 0    | 1     | 0 | 0                           | 0    | 0     | 0 | 0                      | 0    | 0     | 0 | 0                      | 0    | 0     | 0 | 0     | 1             |
| 7:10 AM                         | 0                           | 1    | 1     | 0 | 0                           | 0    | 0     | 0 | 0                      | 0    | 0     | 0 | 0                      | 0    | 0     | 0 | 0     | 2             |
| 7:15 AM                         | 0                           | 0    | 1     | 0 | 0                           | 0    | 0     | 0 | 0                      | 0    | 0     | 0 | 1                      | 0    | 1     | 0 | 0     | 3             |
| 7:20 AM                         | 0                           | 0    | 0     | 0 | 0                           | 0    | 0     | 0 | 0                      | 0    | 0     | 0 | 0                      | 0    | 0     | 0 | 0     | 0             |
| 7:25 AM                         | 0                           | 0    | 0     | 0 | 0                           | 0    | 0     | 0 | 0                      | 0    | 0     | 0 | 0                      | 1    | 0     | 0 | 0     | 1             |
| 7:30 AM                         | 0                           | 0    | 0     | 0 | 0                           | 0    | 0     | 0 | 0                      | 0    | 0     | 0 | 0                      | 0    | 0     | 0 | 0     | 0             |
| 7:35 AM                         | 0                           | 0    | 0     | 0 | 1                           | 0    | 0     | 0 | 0                      | 0    | 0     | 0 | 0                      | 0    | 0     | 0 | 0     | 1             |
| 7:40 AM                         | 0                           | 1    | 1     | 0 | 0                           | 2    | 0     | 0 | 0                      | 0    | 1     | 0 | 0                      | 0    | 4     | 0 | 0     | 9             |
| 7:45 AM                         | 0                           | 3    | 3     | 0 | 0                           | 3    | 0     | 0 | 0                      | 0    | 2     | 0 | 0                      | 3    | 7     | 0 | 0     | 21            |
| 7:50 AM                         | 2                           | 3    | 1     | 0 | 0                           | 4    | 0     | 0 | 0                      | 0    | 2     | 0 | 0                      | 6    | 5     | 0 | 0     | 23            |
| 7:55 AM                         | 0                           | 5    | 4     | 0 | 0                           | 6    | 1     | 0 | 0                      | 0    | 5     | 0 | 0                      | 6    | 6     | 0 | 0     | 33            |
| 8:00 AM                         | 0                           | 4    | 3     | 0 | 0                           | 3    | 0     | 0 | 0                      | 1    | 0     | 0 | 0                      | 1    | 2     | 0 | 0     | 14            |
| 8:05 AM                         | 0                           | 3    | 2     | 0 | 0                           | 1    | 0     | 0 | 0                      | 1    | 1     | 0 | 0                      | 0    | 1     | 1 | 0     | 10            |
| 8:10 AM                         | 1                           | 2    | 1     | 0 | 0                           | 0    | 0     | 0 | 0                      | 0    | 1     | 0 | 0                      | 0    | 0     | 1 | 0     | 6             |
| 8:15 AM                         | 0                           | 0    | 1     | 0 | 0                           | 0    | 0     | 0 | 0                      | 1    | 1     | 0 | 0                      | 0    | 0     | 0 | 0     | 3             |
| 8:20 AM                         | 0                           | 0    | 1     | 0 | 0                           | 0    | 0     | 0 | 0                      | 1    | 0     | 0 | 0                      | 1    | 0     | 0 | 0     | 3             |
| 8:25 AM                         | 0                           | 0    | 0     | 0 | 0                           | 0    | 0     | 0 | 0                      | 1    | 0     | 0 | 0                      | 0    | 1     | 1 | 0     | 3             |
| 8:30 AM                         | 0                           | 0    | 1     | 0 | 0                           | 1    | 0     | 0 | 0                      | 0    | 1     | 0 | 0                      | 2    | 0     | 1 | 0     | 6             |
| 8:35 AM                         | 0                           | 1    | 0     | 0 | 0                           | 0    | 0     | 0 | 0                      | 1    | 1     | 0 | 0                      | 0    | 0     | 0 | 0     | 3             |
| 8:40 AM                         | 0                           | 1    | 1     | 0 | 0                           | 0    | 0     | 0 | 0                      | 0    | 0     | 0 | 0                      | 0    | 0     | 0 | 0     | 2             |
| 8:45 AM                         | 0                           | 1    | 0     | 0 | 0                           | 1    | 0     | 0 | 0                      | 0    | 0     | 0 | 0                      | 3    | 0     | 0 | 0     | 5             |
| 8:50 AM                         | 0                           | 0    | 1     | 0 | 0                           | 2    | 0     | 0 | 0                      | 0    | 0     | 0 | 0                      | 0    | 1     | 0 | 0     | 4             |
| 8:55 AM                         | 0                           | 0    | 1     | 0 | 1                           | 0    | 0     | 0 | 0                      | 0    | 1     | 0 | 0                      | 0    | 0     | 0 | 0     | 3             |
| 9:00 AM                         | 0                           | 0    | 0     | 0 | 0                           | 0    | 0     | 0 | 0                      | 0    | 0     | 0 | 0                      | 0    | 0     | 0 | 0     | 0             |
| 9:05 AM                         | 0                           | 0    | 0     | 0 | 0                           | 0    | 0     | 0 | 0                      | 0    | 0     | 0 | 0                      | 0    | 0     | 0 | 0     | 0             |

Attachment B

| 5-Min Count Period Beginning At | Loch Lomond Rd (Northbound) |      |       |   | Loch Lomond Rd (Southbound) |      |       |   | Chesney Dr (Eastbound) |      |       |   | Chesney Dr (Westbound) |      |       |   | Total | Hourly Totals |
|---------------------------------|-----------------------------|------|-------|---|-----------------------------|------|-------|---|------------------------|------|-------|---|------------------------|------|-------|---|-------|---------------|
|                                 | Left                        | Thru | Right | U | Left                        | Thru | Right | U | Left                   | Thru | Right | U | Left                   | Thru | Right | U |       |               |
| 9:10 AM                         | 0                           | 1    | 0     | 0 | 0                           | 0    | 0     | 0 | 0                      | 0    | 0     | 0 | 0                      | 0    | 0     | 0 | 1     | 33            |
| 9:15 AM                         | 0                           | 0    | 0     | 0 | 1                           | 0    | 0     | 0 | 0                      | 0    | 3     | 0 | 0                      | 0    | 2     | 0 | 6     | 36            |
| 9:20 AM                         | 0                           | 0    | 0     | 0 | 0                           | 1    | 0     | 0 | 0                      | 0    | 0     | 0 | 0                      | 0    | 0     | 0 | 1     | 34            |
| 9:25 AM                         | 0                           | 0    | 0     | 0 | 0                           | 0    | 0     | 0 | 0                      | 0    | 0     | 0 | 0                      | 0    | 0     | 0 | 0     | 31            |
| 9:30 AM                         | 0                           | 0    | 0     | 0 | 0                           | 0    | 0     | 0 | 0                      | 0    | 0     | 0 | 0                      | 0    | 0     | 0 | 0     | 25            |
| 9:35 AM                         | 0                           | 0    | 0     | 0 | 0                           | 0    | 0     | 0 | 0                      | 0    | 0     | 0 | 0                      | 1    | 0     | 0 | 1     | 23            |
| 9:40 AM                         | 0                           | 0    | 0     | 0 | 0                           | 0    | 0     | 0 | 0                      | 0    | 0     | 0 | 0                      | 0    | 0     | 0 | 0     | 21            |
| 9:45 AM                         | 0                           | 0    | 0     | 0 | 0                           | 1    | 0     | 0 | 0                      | 0    | 0     | 0 | 0                      | 1    | 0     | 0 | 2     | 18            |
| 9:50 AM                         | 0                           | 0    | 1     | 0 | 0                           | 0    | 0     | 0 | 0                      | 0    | 0     | 0 | 0                      | 1    | 0     | 0 | 2     | 16            |
| 9:55 AM                         | 0                           | 0    | 0     | 0 | 0                           | 1    | 0     | 0 | 0                      | 0    | 0     | 0 | 0                      | 0    | 0     | 0 | 1     | 14            |
| 10:00 AM                        | 0                           | 0    | 0     | 0 | 0                           | 0    | 0     | 0 | 0                      | 0    | 0     | 0 | 0                      | 0    | 0     | 0 | 0     | 14            |
| 10:05 AM                        | 0                           | 1    | 0     | 0 | 0                           | 0    | 0     | 0 | 0                      | 0    | 0     | 0 | 0                      | 0    | 0     | 0 | 1     | 15            |
| 10:10 AM                        | 0                           | 0    | 0     | 0 | 0                           | 0    | 0     | 0 | 1                      | 0    | 0     | 0 | 0                      | 0    | 0     | 0 | 1     | 15            |
| 10:15 AM                        | 0                           | 0    | 0     | 0 | 0                           | 0    | 0     | 0 | 0                      | 1    | 0     | 0 | 0                      | 2    | 0     | 0 | 3     | 12            |
| 10:20 AM                        | 0                           | 0    | 0     | 0 | 0                           | 0    | 0     | 0 | 0                      | 3    | 0     | 0 | 0                      | 0    | 0     | 0 | 3     | 14            |
| 10:25 AM                        | 0                           | 1    | 0     | 0 | 1                           | 0    | 0     | 0 | 0                      | 0    | 0     | 0 | 1                      | 0    | 0     | 0 | 3     | 17            |
| 10:30 AM                        | 0                           | 1    | 0     | 0 | 0                           | 3    | 0     | 0 | 1                      | 1    | 0     | 0 | 0                      | 1    | 0     | 0 | 7     | 24            |
| 10:35 AM                        | 0                           | 1    | 0     | 0 | 0                           | 0    | 0     | 0 | 0                      | 0    | 0     | 0 | 0                      | 0    | 0     | 0 | 1     | 24            |
| 10:40 AM                        | 0                           | 0    | 1     | 0 | 0                           | 0    | 0     | 0 | 0                      | 0    | 0     | 0 | 0                      | 1    | 0     | 0 | 2     | 26            |
| 10:45 AM                        | 0                           | 0    | 0     | 0 | 0                           | 0    | 0     | 0 | 0                      | 0    | 0     | 0 | 0                      | 0    | 0     | 0 | 0     | 24            |
| 10:50 AM                        | 0                           | 0    | 0     | 0 | 0                           | 1    | 0     | 0 | 0                      | 0    | 0     | 0 | 0                      | 1    | 0     | 0 | 2     | 24            |
| 10:55 AM                        | 0                           | 1    | 0     | 0 | 0                           | 0    | 0     | 0 | 0                      | 1    | 0     | 0 | 0                      | 1    | 0     | 0 | 3     | 26            |
| 11:00 AM                        | 0                           | 1    | 0     | 0 | 0                           | 1    | 0     | 0 | 0                      | 0    | 0     | 0 | 0                      | 0    | 0     | 0 | 2     | 28            |
| 11:05 AM                        | 0                           | 0    | 0     | 0 | 0                           | 0    | 0     | 0 | 0                      | 2    | 0     | 0 | 0                      | 2    | 1     | 0 | 5     | 32            |
| 11:10 AM                        | 0                           | 1    | 0     | 0 | 0                           | 2    | 0     | 0 | 0                      | 0    | 0     | 0 | 0                      | 2    | 0     | 0 | 5     | 36            |
| 11:15 AM                        | 0                           | 0    | 0     | 0 | 1                           | 0    | 0     | 0 | 0                      | 0    | 0     | 0 | 0                      | 0    | 0     | 0 | 1     | 34            |
| 11:20 AM                        | 0                           | 1    | 0     | 0 | 0                           | 2    | 1     | 0 | 0                      | 0    | 0     | 0 | 0                      | 0    | 0     | 0 | 4     | 35            |
| 11:25 AM                        | 0                           | 1    | 0     | 0 | 0                           | 0    | 0     | 0 | 0                      | 0    | 0     | 0 | 0                      | 0    | 0     | 0 | 1     | 33            |
| 11:30 AM                        | 0                           | 2    | 0     | 0 | 0                           | 0    | 0     | 0 | 0                      | 1    | 0     | 0 | 0                      | 0    | 1     | 0 | 4     | 30            |
| 11:35 AM                        | 0                           | 0    | 0     | 0 | 0                           | 1    | 0     | 0 | 0                      | 0    | 0     | 0 | 0                      | 2    | 0     | 0 | 3     | 32            |
| 11:40 AM                        | 0                           | 0    | 0     | 0 | 1                           | 1    | 0     | 0 | 0                      | 0    | 0     | 0 | 1                      | 0    | 1     | 0 | 4     | 34            |
| 11:45 AM                        | 0                           | 0    | 0     | 0 | 0                           | 1    | 0     | 0 | 0                      | 0    | 0     | 0 | 0                      | 0    | 0     | 0 | 1     | 35            |
| 11:50 AM                        | 0                           | 0    | 0     | 0 | 0                           | 0    | 0     | 0 | 0                      | 0    | 0     | 0 | 0                      | 1    | 1     | 0 | 2     | 35            |
| 11:55 AM                        | 0                           | 0    | 1     | 0 | 0                           | 0    | 0     | 0 | 0                      | 1    | 0     | 0 | 0                      | 0    | 0     | 0 | 2     | 34            |
| 12:00 PM                        | 0                           | 0    | 0     | 0 | 0                           | 0    | 0     | 0 | 0                      | 1    | 0     | 0 | 0                      | 0    | 1     | 0 | 2     | 34            |
| 12:05 PM                        | 0                           | 0    | 0     | 0 | 0                           | 0    | 0     | 0 | 0                      | 2    | 0     | 0 | 0                      | 0    | 1     | 0 | 3     | 32            |
| 12:10 PM                        | 0                           | 0    | 0     | 0 | 0                           | 0    | 0     | 0 | 0                      | 0    | 0     | 0 | 0                      | 0    | 1     | 0 | 1     | 28            |
| 12:15 PM                        | 0                           | 0    | 0     | 0 | 0                           | 0    | 0     | 0 | 0                      | 0    | 0     | 0 | 0                      | 0    | 0     | 0 | 0     | 27            |
| 12:20 PM                        | 0                           | 1    | 0     | 0 | 0                           | 0    | 0     | 0 | 1                      | 1    | 0     | 0 | 0                      | 0    | 1     | 0 | 4     | 27            |
| 12:25 PM                        | 0                           | 0    | 0     | 0 | 0                           | 0    | 0     | 0 | 0                      | 0    | 0     | 0 | 0                      | 0    | 0     | 0 | 0     | 26            |
| 12:30 PM                        | 0                           | 0    | 0     | 0 | 0                           | 1    | 0     | 0 | 0                      | 0    | 0     | 0 | 0                      | 0    | 0     | 0 | 1     | 23            |
| 12:35 PM                        | 0                           | 0    | 0     | 0 | 0                           | 0    | 1     | 0 | 0                      | 1    | 0     | 0 | 0                      | 1    | 0     | 0 | 3     | 23            |
| 12:40 PM                        | 0                           | 0    | 1     | 0 | 0                           | 0    | 0     | 0 | 1                      | 0    | 0     | 0 | 0                      | 0    | 1     | 0 | 3     | 22            |
| 12:45 PM                        | 0                           | 0    | 0     | 0 | 0                           | 0    | 1     | 0 | 0                      | 2    | 0     | 0 | 0                      | 0    | 1     | 0 | 4     | 25            |
| 12:50 PM                        | 0                           | 0    | 0     | 0 | 0                           | 0    | 0     | 0 | 0                      | 1    | 0     | 0 | 0                      | 1    | 1     | 0 | 3     | 26            |
| 12:55 PM                        | 0                           | 0    | 0     | 0 | 0                           | 0    | 1     | 0 | 0                      | 0    | 1     | 0 | 0                      | 1    | 0     | 0 | 3     | 27            |
| 1:00 PM                         | 0                           | 0    | 0     | 0 | 0                           | 1    | 1     | 0 | 0                      | 0    | 0     | 0 | 0                      | 0    | 0     | 0 | 2     | 27            |
| 1:05 PM                         | 0                           | 1    | 0     | 0 | 0                           | 1    | 0     | 0 | 0                      | 0    | 0     | 0 | 0                      | 0    | 0     | 0 | 2     | 26            |
| 1:10 PM                         | 0                           | 1    | 0     | 0 | 0                           | 0    | 0     | 0 | 0                      | 0    | 0     | 0 | 1                      | 0    | 0     | 0 | 2     | 27            |
| 1:15 PM                         | 0                           | 0    | 1     | 0 | 1                           | 2    | 0     | 0 | 0                      | 0    | 0     | 0 | 0                      | 2    | 0     | 0 | 6     | 33            |
| 1:20 PM                         | 0                           | 0    | 0     | 0 | 0                           | 4    | 0     | 0 | 0                      | 1    | 0     | 0 | 1                      | 2    | 0     | 0 | 8     | 37            |
| 1:25 PM                         | 0                           | 0    | 0     | 0 | 0                           | 2    | 0     | 0 | 0                      | 1    | 0     | 0 | 0                      | 5    | 0     | 0 | 8     | 45            |
| 1:30 PM                         | 1                           | 2    | 3     | 0 | 0                           | 1    | 0     | 0 | 1                      | 0    | 0     | 0 | 0                      | 5    | 0     | 0 | 13    | 57            |
| 1:35 PM                         | 0                           | 5    | 3     | 0 | 1                           | 2    | 0     | 0 | 0                      | 5    | 0     | 0 | 0                      | 2    | 0     | 0 | 18    | 72            |
| 1:40 PM                         | 0                           | 1    | 1     | 0 | 0                           | 1    | 0     | 0 | 0                      | 2    | 0     | 0 | 0                      | 0    | 0     | 0 | 5     | 74            |
| 1:45 PM                         | 0                           | 1    | 0     | 0 | 0                           | 1    | 0     | 0 | 0                      | 2    | 0     | 0 | 1                      | 0    | 0     | 0 | 5     | 75            |
| 1:50 PM                         | 0                           | 1    | 1     | 0 | 0                           | 1    | 0     | 0 | 0                      | 0    | 0     | 0 | 0                      | 0    | 0     | 0 | 3     | 75            |
| 1:55 PM                         | 0                           | 0    | 0     | 0 | 0                           | 0    | 0     | 0 | 0                      | 0    | 0     | 0 | 0                      | 1    | 0     | 0 | 1     | 73            |
| 2:00 PM                         | 0                           | 0    | 0     | 0 | 0                           | 0    | 0     | 0 | 0                      | 0    | 0     | 0 | 0                      | 0    | 2     | 0 | 2     | 73            |
| 2:05 PM                         | 0                           | 0    | 0     | 0 | 0                           | 1    | 0     | 0 | 0                      | 0    | 0     | 0 | 0                      | 0    | 0     | 0 | 1     | 72            |
| 2:10 PM                         | 0                           | 1    | 1     | 0 | 0                           | 1    | 0     | 0 | 1                      | 0    | 0     | 0 | 0                      | 1    | 0     | 0 | 5     | 75            |
| 2:15 PM                         | 0                           | 0    | 0     | 0 | 0                           | 1    | 0     | 0 | 0                      | 0    | 0     | 0 | 1                      | 0    | 0     | 0 | 2     | 71            |
| 2:20 PM                         | 0                           | 0    | 0     | 0 | 0                           | 0    | 0     | 0 | 0                      | 0    | 0     | 0 | 0                      | 1    | 1     | 0 | 2     | 65            |
| 2:25 PM                         | 0                           | 1    | 0     | 0 | 0                           | 0    | 0     | 0 | 0                      | 1    | 0     | 0 | 0                      | 1    | 0     | 0 | 3     | 60            |
| 2:30 PM                         | 0                           | 1    | 1     | 0 | 0                           | 0    | 0     | 0 | 0                      | 0    | 0     | 0 | 1                      | 1    | 0     | 0 | 4     | 51            |
| 2:35 PM                         | 0                           | 0    | 0     | 0 | 1                           | 0    | 0     | 0 | 1                      | 1    | 0     | 0 | 0                      | 1    | 0     | 0 | 4     | 37            |
| 2:40 PM                         | 0                           | 0    | 0     | 0 | 0                           | 1    | 1     | 0 | 0                      | 1    | 0     | 0 | 0                      | 0    | 0     | 0 | 3     | 35            |
| 2:45 PM                         | 0                           | 0    | 0     | 0 | 0                           | 0    | 0     | 0 | 0                      | 1    | 0     | 0 | 1                      | 0    | 0     | 0 | 2     | 32            |
| 2:50 PM                         | 0                           | 0    | 0     | 0 | 0                           | 1    | 0     | 0 | 0                      | 0    | 0     | 0 | 0                      | 2    | 0     | 0 | 3     | 32            |
| 2:55 PM                         | 0                           | 2    | 0     | 0 | 0                           | 1    | 0     | 0 | 0                      | 0    | 1     | 0 | 0                      | 1    | 0     | 0 | 5     | 36            |
| 3:00 PM                         | 0                           | 0    | 0     | 0 | 0                           | 0    | 0     | 0 | 0                      | 1    | 0     | 0 | 0                      | 0    | 1     | 0 | 2     | 36            |
| 3:05 PM                         | 0                           | 0    | 0     | 0 | 0                           | 0    | 0     | 0 | 0                      | 0    | 0     | 0 | 0                      | 1    | 0     | 0 | 1     | 36            |
| 3:10 PM                         | 0                           | 0    | 0     | 0 | 1                           | 0    | 1     | 0 | 0                      | 0    | 0     | 0 | 0                      | 0    | 0     | 0 | 2     | 33            |
| 3:15 PM                         | 0                           | 0    | 0     | 0 | 0                           | 2    | 0     | 0 | 0                      | 0    | 0     | 0 | 1                      | 1    | 0     | 0 | 4     | 35            |
| 3:20 PM                         | 0                           | 2    | 1     | 0 | 0                           | 0    | 0     | 0 | 0                      | 0    | 0     | 0 | 0                      | 0    | 0     | 0 | 3     | 36            |
| 3:25 PM                         | 0                           | 1    | 0     | 0 | 0                           | 0    | 0     | 0 | 0                      | 1    | 0     | 0 | 0                      | 0    | 0     | 0 | 2     | 35            |
| 3:30 PM                         | 0                           | 0    | 0     | 0 | 0                           | 0    | 0     | 0 | 0                      | 1    | 0     | 0 | 0                      | 0    | 1     | 0 | 2     | 33            |
| 3:35 PM                         | 0                           | 1    | 0     | 0 | 0                           | 0    | 0     | 0 | 0                      | 1    | 0     | 0 | 0                      | 0    | 0     | 0 | 2     | 31            |
| 3:40 PM                         | 0                           | 0    | 0     | 0 | 0                           | 0    | 0     | 0 | 0                      | 0    | 0     | 0 | 0                      | 1    | 0     | 0 | 1     | 29            |
| 3:45 PM                         | 0                           | 2    | 0     | 0 | 0                           | 1    | 0     | 0 | 0                      | 2    | 0     | 0 | 0                      | 0    | 0     | 0 | 5     | 32            |
| 3:50 PM                         | 0                           | 0    | 0     | 0 | 1                           | 0    | 0     | 0 | 0                      | 1    | 0     | 0 | 0                      | 1    | 0     | 0 | 3     | 32            |
| 3:55 PM                         | 0                           | 0    | 0     | 0 | 0                           | 0    | 1     | 0 | 0                      | 1    | 0     | 0 | 0                      | 1    | 0     | 0 | 3     | 30            |
| 4:00 PM                         | 0                           | 0    | 1     | 0 | 0                           | 0    | 0     | 0 | 0                      | 2    | 0     | 0 | 0                      | 0    | 0     | 0 | 3     | 31            |
| 4:05 PM                         | 0                           | 0    | 0     | 0 | 0                           | 0    | 0     | 0 | 0                      | 1    | 0     | 0 | 0                      | 1    | 0     | 0 | 2     | 32            |
| 4:10 PM                         | 0                           | 1    | 0     | 0 | 0                           | 1    | 0     | 0 | 0                      | 0    | 0     | 0 | 0                      | 2    | 0     | 0 | 4     | 34            |
| 4:15 PM                         | 0                           | 0    | 0     | 0 | 0                           | 1    | 0     | 0 | 0                      | 1    | 0     | 0 | 0                      | 0    | 0     | 0 | 2     | 32            |
| 4:20 PM                         | 0                           | 1    | 0     | 0 | 1                           | 1    | 0     | 0 | 0                      | 0    | 0     | 0 | 0                      | 1    | 0     | 0 | 4     | 33            |
| 4:25 PM                         | 0                           | 0    | 0     | 0 | 0                           | 2    | 0     | 0 | 0                      | 0    | 0     | 0 | 0                      | 0    | 0     | 0 | 2     | 33            |
| 4:30 PM                         | 0                           | 0    | 0     | 0 | 0                           | 1    | 0     | 0 | 1                      | 2    | 0     | 0 | 0                      | 1    | 0     | 0 | 5     | 36            |

**Attachment B**

| 5-Min Count Period Beginning At | Loch Lomond Rd (Northbound) |      |       |   | Loch Lomond Rd (Southbound) |      |       |   | Chesney Dr (Eastbound) |      |       |   | Chesney Dr (Westbound) |      |       |   | Total | Hourly Totals |    |
|---------------------------------|-----------------------------|------|-------|---|-----------------------------|------|-------|---|------------------------|------|-------|---|------------------------|------|-------|---|-------|---------------|----|
|                                 | Left                        | Thru | Right | U | Left                        | Thru | Right | U | Left                   | Thru | Right | U | Left                   | Thru | Right | U |       |               |    |
| 4:35 PM                         | 0                           | 0    | 0     | 0 | 0                           | 1    | 0     | 0 | 0                      | 0    | 0     | 0 | 0                      | 1    | 2     | 0 | 0     | 4             | 38 |
| 4:40 PM                         | 0                           | 0    | 0     | 0 | 0                           | 0    | 0     | 0 | 0                      | 0    | 1     | 0 | 0                      | 0    | 1     | 0 | 0     | 2             | 39 |
| 4:45 PM                         | 0                           | 0    | 1     | 0 | 0                           | 0    | 0     | 0 | 0                      | 0    | 1     | 0 | 0                      | 0    | 2     | 0 | 0     | 4             | 38 |
| 4:50 PM                         | 0                           | 0    | 0     | 0 | 1                           | 1    | 0     | 0 | 1                      | 2    | 0     | 0 | 1                      | 1    | 1     | 0 | 0     | 8             | 43 |
| 4:55 PM                         | 0                           | 0    | 0     | 0 | 1                           | 0    | 0     | 0 | 0                      | 2    | 0     | 0 | 0                      | 2    | 0     | 0 | 0     | 5             | 45 |
| 5:00 PM                         | 0                           | 0    | 0     | 0 | 0                           | 0    | 0     | 0 | 0                      | 1    | 0     | 0 | 0                      | 1    | 1     | 0 | 0     | 3             | 45 |
| 5:05 PM                         | 0                           | 1    | 0     | 0 | 1                           | 0    | 0     | 0 | 0                      | 0    | 0     | 0 | 0                      | 0    | 0     | 0 | 0     | 2             | 45 |
| 5:10 PM                         | 0                           | 0    | 0     | 0 | 0                           | 0    | 0     | 0 | 0                      | 0    | 0     | 0 | 0                      | 2    | 0     | 0 | 0     | 2             | 43 |
| 5:15 PM                         | 0                           | 0    | 0     | 0 | 0                           | 1    | 0     | 0 | 0                      | 0    | 0     | 0 | 0                      | 1    | 1     | 0 | 0     | 3             | 44 |
| 5:20 PM                         | 0                           | 1    | 0     | 0 | 0                           | 0    | 0     | 0 | 0                      | 0    | 0     | 0 | 0                      | 0    | 0     | 0 | 0     | 1             | 41 |
| 5:25 PM                         | 0                           | 0    | 0     | 0 | 0                           | 0    | 0     | 0 | 0                      | 1    | 0     | 0 | 0                      | 1    | 0     | 0 | 0     | 2             | 41 |
| 5:30 PM                         | 0                           | 2    | 0     | 0 | 1                           | 0    | 0     | 0 | 0                      | 0    | 0     | 0 | 0                      | 0    | 0     | 0 | 0     | 3             | 39 |
| 5:35 PM                         | 0                           | 0    | 0     | 0 | 0                           | 1    | 0     | 0 | 0                      | 0    | 1     | 0 | 0                      | 0    | 1     | 0 | 0     | 3             | 38 |
| 5:40 PM                         | 0                           | 0    | 0     | 0 | 0                           | 1    | 0     | 0 | 0                      | 0    | 0     | 0 | 0                      | 0    | 0     | 0 | 0     | 1             | 37 |
| 5:45 PM                         | 0                           | 1    | 0     | 0 | 0                           | 0    | 0     | 0 | 0                      | 2    | 0     | 0 | 0                      | 0    | 0     | 0 | 0     | 3             | 36 |
| 5:50 PM                         | 0                           | 0    | 0     | 0 | 0                           | 0    | 0     | 0 | 0                      | 1    | 0     | 0 | 0                      | 0    | 0     | 0 | 0     | 1             | 29 |
| 5:55 PM                         | 0                           | 0    | 0     | 0 | 0                           | 0    | 0     | 0 | 0                      | 0    | 0     | 0 | 0                      | 0    | 0     | 0 | 0     | 0             | 24 |
| 6:00 PM                         | 0                           | 1    | 0     | 0 | 0                           | 1    | 1     | 0 | 0                      | 0    | 0     | 0 | 1                      | 0    | 0     | 0 | 0     | 4             | 25 |
| 6:05 PM                         | 0                           | 1    | 0     | 0 | 0                           | 0    | 0     | 0 | 0                      | 1    | 0     | 0 | 0                      | 1    | 0     | 0 | 0     | 3             | 26 |
| 6:10 PM                         | 0                           | 0    | 0     | 0 | 1                           | 0    | 0     | 0 | 1                      | 1    | 0     | 0 | 0                      | 1    | 0     | 0 | 0     | 4             | 28 |
| 6:15 PM                         | 0                           | 0    | 0     | 0 | 0                           | 0    | 0     | 0 | 0                      | 0    | 0     | 0 | 0                      | 3    | 1     | 0 | 0     | 4             | 29 |
| 6:20 PM                         | 0                           | 0    | 0     | 0 | 0                           | 1    | 0     | 0 | 0                      | 0    | 1     | 0 | 0                      | 2    | 0     | 0 | 0     | 4             | 32 |
| 6:25 PM                         | 0                           | 0    | 1     | 0 | 0                           | 0    | 0     | 0 | 0                      | 1    | 0     | 0 | 0                      | 1    | 0     | 0 | 0     | 3             | 33 |
| 6:30 PM                         | 0                           | 0    | 0     | 0 | 0                           | 0    | 0     | 0 | 0                      | 1    | 0     | 0 | 0                      | 0    | 0     | 0 | 0     | 1             | 31 |
| 6:35 PM                         | 0                           | 0    | 1     | 0 | 0                           | 1    | 0     | 0 | 0                      | 0    | 0     | 0 | 0                      | 2    | 0     | 0 | 0     | 4             | 32 |
| 6:40 PM                         | 0                           | 0    | 0     | 0 | 0                           | 0    | 0     | 0 | 1                      | 2    | 0     | 0 | 1                      | 3    | 1     | 0 | 0     | 8             | 39 |
| 6:45 PM                         | 0                           | 0    | 0     | 0 | 0                           | 0    | 0     | 0 | 0                      | 1    | 0     | 0 | 0                      | 0    | 0     | 0 | 0     | 1             | 37 |
| 6:50 PM                         | 0                           | 0    | 0     | 0 | 0                           | 1    | 0     | 0 | 0                      | 0    | 0     | 0 | 1                      | 0    | 0     | 0 | 0     | 2             | 38 |
| 6:55 PM                         | 0                           | 1    | 0     | 0 | 0                           | 1    | 0     | 0 | 0                      | 1    | 0     | 0 | 0                      | 0    | 0     | 0 | 0     | 3             | 41 |
| 7:00 PM                         | 0                           | 0    | 0     | 0 | 0                           | 3    | 0     | 0 | 0                      | 0    | 0     | 0 | 0                      | 1    | 0     | 0 | 0     | 4             | 41 |
| 7:05 PM                         | 1                           | 1    | 1     | 0 | 0                           | 0    | 0     | 0 | 0                      | 0    | 0     | 0 | 0                      | 0    | 0     | 0 | 0     | 3             | 41 |
| 7:10 PM                         | 0                           | 0    | 0     | 0 | 0                           | 0    | 0     | 0 | 0                      | 0    | 0     | 0 | 0                      | 1    | 0     | 0 | 0     | 1             | 38 |
| 7:15 PM                         | 0                           | 2    | 0     | 0 | 0                           | 0    | 0     | 0 | 0                      | 1    | 0     | 0 | 0                      | 0    | 0     | 0 | 0     | 3             | 37 |
| 7:20 PM                         | 0                           | 0    | 0     | 0 | 0                           | 0    | 0     | 0 | 0                      | 0    | 0     | 0 | 0                      | 0    | 0     | 0 | 0     | 0             | 33 |
| 7:25 PM                         | 0                           | 1    | 0     | 0 | 0                           | 0    | 0     | 0 | 0                      | 1    | 0     | 0 | 0                      | 0    | 1     | 0 | 0     | 3             | 33 |
| 7:30 PM                         | 0                           | 0    | 0     | 0 | 0                           | 0    | 1     | 0 | 0                      | 0    | 1     | 0 | 0                      | 0    | 0     | 0 | 0     | 2             | 34 |
| 7:35 PM                         | 0                           | 0    | 0     | 0 | 0                           | 0    | 0     | 0 | 0                      | 0    | 0     | 0 | 0                      | 0    | 0     | 0 | 0     | 0             | 30 |
| 7:40 PM                         | 0                           | 0    | 0     | 0 | 0                           | 2    | 0     | 0 | 0                      | 0    | 0     | 0 | 0                      | 1    | 1     | 0 | 0     | 4             | 26 |
| 7:45 PM                         | 0                           | 0    | 0     | 0 | 0                           | 0    | 0     | 0 | 0                      | 0    | 0     | 0 | 0                      | 1    | 0     | 0 | 0     | 1             | 26 |
| 7:50 PM                         | 0                           | 0    | 0     | 0 | 0                           | 0    | 0     | 0 | 0                      | 0    | 0     | 0 | 0                      | 0    | 1     | 0 | 0     | 1             | 25 |
| 7:55 PM                         | 0                           | 0    | 0     | 0 | 0                           | 1    | 0     | 0 | 0                      | 0    | 0     | 0 | 0                      | 0    | 0     | 0 | 0     | 1             | 23 |
| 8:00 PM                         | 0                           | 0    | 0     | 0 | 0                           | 0    | 0     | 0 | 0                      | 0    | 0     | 0 | 0                      | 0    | 0     | 0 | 0     | 0             | 19 |
| 8:05 PM                         | 0                           | 0    | 0     | 0 | 0                           | 0    | 0     | 0 | 0                      | 0    | 0     | 0 | 0                      | 0    | 0     | 0 | 0     | 0             | 16 |
| 8:10 PM                         | 0                           | 0    | 0     | 0 | 0                           | 0    | 0     | 0 | 0                      | 0    | 0     | 0 | 0                      | 0    | 0     | 0 | 0     | 0             | 15 |
| 8:15 PM                         | 0                           | 0    | 0     | 0 | 0                           | 0    | 1     | 0 | 0                      | 0    | 0     | 0 | 0                      | 1    | 0     | 0 | 0     | 2             | 14 |
| 8:20 PM                         | 0                           | 0    | 0     | 0 | 0                           | 0    | 0     | 0 | 0                      | 0    | 0     | 0 | 0                      | 1    | 0     | 0 | 0     | 1             | 15 |
| 8:25 PM                         | 0                           | 0    | 0     | 0 | 0                           | 0    | 0     | 0 | 0                      | 0    | 0     | 0 | 0                      | 0    | 0     | 0 | 0     | 0             | 12 |
| 8:30 PM                         | 0                           | 0    | 0     | 0 | 0                           | 0    | 0     | 0 | 0                      | 0    | 0     | 0 | 0                      | 0    | 0     | 0 | 0     | 0             | 10 |
| 8:35 PM                         | 0                           | 0    | 0     | 0 | 0                           | 0    | 1     | 0 | 0                      | 0    | 0     | 0 | 1                      | 0    | 0     | 0 | 0     | 2             | 12 |
| 8:40 PM                         | 0                           | 0    | 0     | 0 | 0                           | 1    | 0     | 0 | 0                      | 0    | 0     | 0 | 0                      | 0    | 0     | 0 | 0     | 1             | 9  |
| 8:45 PM                         | 0                           | 0    | 0     | 0 | 0                           | 0    | 0     | 0 | 0                      | 1    | 0     | 0 | 1                      | 0    | 0     | 0 | 0     | 2             | 10 |
| 8:50 PM                         | 0                           | 0    | 0     | 0 | 0                           | 0    | 0     | 0 | 0                      | 0    | 0     | 0 | 0                      | 2    | 0     | 0 | 0     | 2             | 11 |
| 8:55 PM                         | 0                           | 0    | 0     | 0 | 0                           | 1    | 0     | 0 | 0                      | 0    | 0     | 0 | 0                      | 0    | 0     | 0 | 0     | 1             | 11 |
| 9:00 PM                         | 0                           | 0    | 0     | 0 | 0                           | 0    | 0     | 0 | 0                      | 0    | 0     | 0 | 0                      | 0    | 0     | 0 | 0     | 0             | 11 |
| 9:05 PM                         | 0                           | 0    | 0     | 0 | 0                           | 0    | 0     | 0 | 0                      | 0    | 0     | 0 | 0                      | 0    | 0     | 0 | 0     | 0             | 11 |
| 9:10 PM                         | 0                           | 0    | 0     | 0 | 0                           | 0    | 0     | 0 | 0                      | 0    | 0     | 0 | 0                      | 0    | 0     | 0 | 0     | 0             | 11 |
| 9:15 PM                         | 0                           | 0    | 0     | 0 | 0                           | 0    | 0     | 0 | 0                      | 0    | 0     | 0 | 0                      | 1    | 0     | 0 | 0     | 1             | 10 |
| 9:20 PM                         | 0                           | 0    | 0     | 0 | 0                           | 0    | 0     | 0 | 0                      | 0    | 0     | 0 | 0                      | 1    | 0     | 0 | 0     | 1             | 10 |
| 9:25 PM                         | 0                           | 0    | 0     | 0 | 0                           | 0    | 0     | 0 | 0                      | 0    | 0     | 0 | 0                      | 0    | 0     | 0 | 0     | 0             | 10 |
| 9:30 PM                         | 0                           | 0    | 0     | 0 | 0                           | 0    | 0     | 0 | 0                      | 0    | 0     | 0 | 0                      | 0    | 0     | 0 | 0     | 0             | 10 |
| 9:35 PM                         | 0                           | 0    | 0     | 0 | 0                           | 0    | 0     | 0 | 0                      | 1    | 0     | 0 | 0                      | 0    | 0     | 0 | 0     | 1             | 9  |
| 9:40 PM                         | 0                           | 0    | 0     | 0 | 0                           | 0    | 0     | 0 | 0                      | 0    | 0     | 0 | 0                      | 0    | 0     | 0 | 0     | 0             | 8  |
| 9:45 PM                         | 0                           | 0    | 0     | 0 | 0                           | 0    | 0     | 0 | 1                      | 0    | 0     | 0 | 0                      | 0    | 0     | 0 | 0     | 1             | 7  |
| 9:50 PM                         | 0                           | 0    | 0     | 0 | 0                           | 0    | 0     | 0 | 0                      | 0    | 0     | 0 | 0                      | 0    | 0     | 0 | 0     | 0             | 5  |
| 9:55 PM                         | 0                           | 0    | 0     | 0 | 0                           | 0    | 0     | 0 | 0                      | 0    | 0     | 0 | 0                      | 0    | 0     | 0 | 0     | 0             | 4  |
| Peak 15-Min Flowrates           | Northbound                  |      |       |   | Southbound                  |      |       |   | Eastbound              |      |       |   | Westbound              |      |       |   | Total |               |    |
|                                 | Left                        | Thru | Right | U | Left                        | Thru | Right | U | Left                   | Thru | Right | U | Left                   | Thru | Right | U |       |               |    |
| All Vehicles                    | 8                           | 44   | 32    | 0 | 0                           | 52   | 4     | 0 | 0                      | 36   | 0     | 0 | 60                     | 72   | 0     | 0 | 308   |               |    |
| Heavy Trucks                    | 0                           | 0    | 0     | 0 | 0                           | 0    | 0     | 0 | 0                      | 0    | 0     | 0 | 0                      | 0    | 0     | 0 | 0     |               |    |
| Buses                           |                             |      |       |   |                             |      |       |   |                        |      |       |   |                        |      |       |   |       |               |    |
| Pedestrians                     |                             | 4    |       |   |                             | 0    |       |   |                        | 0    |       |   |                        | 8    |       |   | 12    |               |    |
| Bicycles                        | 0                           | 0    | 0     |   | 0                           | 0    | 0     |   | 0                      | 0    | 0     |   | 0                      | 0    | 0     |   | 0     |               |    |
| Scoters                         |                             |      |       |   |                             |      |       |   |                        |      |       |   |                        |      |       |   |       |               |    |
| <i>Comments:</i>                |                             |      |       |   |                             |      |       |   |                        |      |       |   |                        |      |       |   |       |               |    |

Report generated on 4/25/2025 4:02 PM

SOURCE: Quality Counts, LLC (<http://www.qualitycounts.net>) 1-877-580-2212

LOCATION: Donnis Rd -- Quail Run Rd  
 CITY/STATE: Rossmore, CA

QC JOB #: 16966420  
 DATE: Wed, Apr 9 2025

Peak-Hour: 7:40 AM -- 8:40 AM  
 Peak 15-Min: 8:00 AM -- 8:15 AM

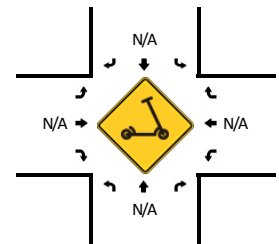
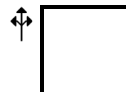
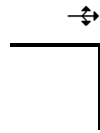
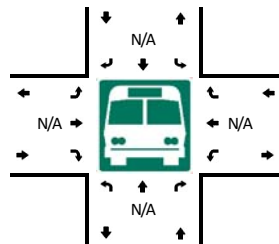
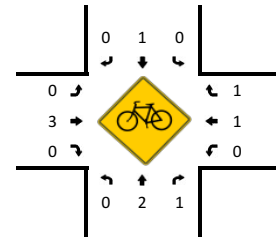
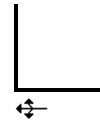
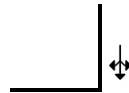
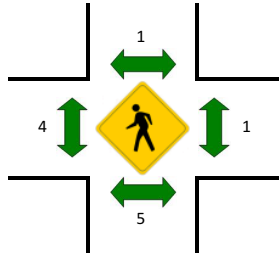
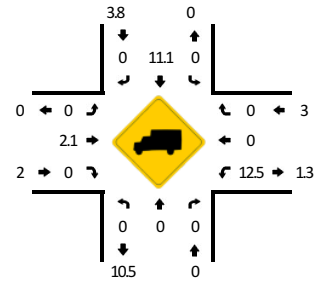
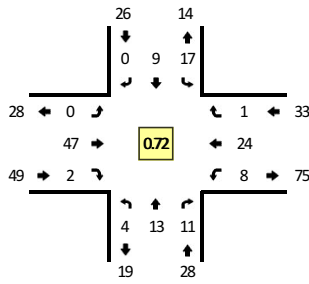

| 5-Min Count Period Beginning At | Donnis Rd (Northbound) |      |       |   | Donnis Rd (Southbound) |      |       |   | Quail Run Rd (Eastbound) |      |       |   | Quail Run Rd (Westbound) |      |       |   | Total | Hourly Totals |
|---------------------------------|------------------------|------|-------|---|------------------------|------|-------|---|--------------------------|------|-------|---|--------------------------|------|-------|---|-------|---------------|
|                                 | Left                   | Thru | Right | U | Left                   | Thru | Right | U | Left                     | Thru | Right | U | Left                     | Thru | Right | U |       |               |
| 6:00 AM                         | 0                      | 0    | 0     | 0 | 0                      | 0    | 0     | 0 | 0                        | 2    | 0     | 0 | 0                        | 0    | 0     | 0 | 2     |               |
| 6:05 AM                         | 0                      | 0    | 0     | 0 | 0                      | 0    | 0     | 0 | 0                        | 0    | 2     | 0 | 0                        | 1    | 1     | 0 | 4     |               |
| 6:10 AM                         | 0                      | 0    | 0     | 0 | 0                      | 0    | 0     | 0 | 0                        | 0    | 1     | 0 | 0                        | 0    | 0     | 0 | 1     |               |
| 6:15 AM                         | 0                      | 0    | 0     | 0 | 0                      | 0    | 0     | 0 | 0                        | 0    | 0     | 0 | 0                        | 0    | 1     | 0 | 1     |               |
| 6:20 AM                         | 0                      | 0    | 0     | 0 | 0                      | 0    | 0     | 0 | 0                        | 0    | 1     | 0 | 0                        | 0    | 1     | 0 | 2     |               |
| 6:25 AM                         | 0                      | 0    | 0     | 0 | 0                      | 0    | 0     | 0 | 0                        | 0    | 0     | 0 | 0                        | 0    | 0     | 0 | 0     |               |
| 6:30 AM                         | 0                      | 0    | 0     | 0 | 0                      | 0    | 0     | 0 | 0                        | 0    | 1     | 0 | 0                        | 0    | 0     | 0 | 1     |               |
| 6:35 AM                         | 0                      | 0    | 0     | 0 | 0                      | 0    | 0     | 0 | 0                        | 0    | 1     | 0 | 0                        | 0    | 0     | 0 | 1     |               |
| 6:40 AM                         | 0                      | 0    | 0     | 0 | 0                      | 0    | 0     | 0 | 0                        | 0    | 0     | 1 | 0                        | 0    | 0     | 0 | 1     |               |
| 6:45 AM                         | 0                      | 0    | 1     | 0 | 0                      | 0    | 0     | 0 | 0                        | 0    | 0     | 0 | 0                        | 0    | 0     | 0 | 1     |               |
| 6:50 AM                         | 0                      | 0    | 0     | 0 | 0                      | 0    | 0     | 0 | 0                        | 0    | 1     | 0 | 0                        | 0    | 0     | 0 | 1     |               |
| 6:55 AM                         | 0                      | 0    | 0     | 0 | 0                      | 0    | 0     | 0 | 0                        | 0    | 1     | 0 | 0                        | 0    | 2     | 0 | 3     | 18            |
| 7:00 AM                         | 0                      | 0    | 0     | 0 | 0                      | 1    | 1     | 0 | 0                        | 0    | 3     | 0 | 0                        | 0    | 1     | 0 | 6     | 22            |
| 7:05 AM                         | 0                      | 0    | 0     | 0 | 0                      | 0    | 0     | 0 | 0                        | 0    | 6     | 0 | 0                        | 0    | 1     | 0 | 7     | 25            |
| 7:10 AM                         | 0                      | 0    | 0     | 0 | 0                      | 0    | 0     | 0 | 0                        | 0    | 2     | 0 | 0                        | 0    | 0     | 0 | 2     | 26            |
| 7:15 AM                         | 0                      | 1    | 0     | 0 | 2                      | 0    | 0     | 0 | 0                        | 0    | 2     | 0 | 0                        | 0    | 0     | 0 | 5     | 30            |
| 7:20 AM                         | 0                      | 0    | 0     | 0 | 0                      | 1    | 0     | 0 | 0                        | 0    | 3     | 0 | 0                        | 0    | 0     | 0 | 4     | 32            |
| 7:25 AM                         | 0                      | 0    | 0     | 0 | 0                      | 1    | 0     | 0 | 0                        | 0    | 1     | 0 | 0                        | 0    | 1     | 0 | 3     | 35            |
| 7:30 AM                         | 0                      | 1    | 0     | 0 | 2                      | 0    | 1     | 0 | 0                        | 0    | 2     | 0 | 0                        | 0    | 1     | 0 | 7     | 41            |
| 7:35 AM                         | 0                      | 0    | 0     | 0 | 0                      | 0    | 0     | 0 | 0                        | 0    | 1     | 0 | 0                        | 0    | 1     | 0 | 2     | 42            |
| 7:40 AM                         | 0                      | 2    | 1     | 0 | 2                      | 1    | 0     | 0 | 0                        | 0    | 4     | 0 | 0                        | 2    | 1     | 0 | 13    | 54            |
| 7:45 AM                         | 0                      | 0    | 2     | 0 | 0                      | 0    | 0     | 0 | 0                        | 0    | 3     | 1 | 0                        | 1    | 3     | 0 | 10    | 63            |
| 7:50 AM                         | 1                      | 2    | 2     | 0 | 1                      | 0    | 0     | 0 | 0                        | 0    | 3     | 0 | 0                        | 0    | 5     | 1 | 15    | 77            |
| 7:55 AM                         | 0                      | 2    | 2     | 0 | 2                      | 0    | 0     | 0 | 0                        | 0    | 2     | 0 | 0                        | 0    | 7     | 0 | 15    | 89            |
| 8:00 AM                         | 0                      | 1    | 1     | 0 | 2                      | 0    | 0     | 0 | 0                        | 0    | 4     | 0 | 0                        | 2    | 1     | 0 | 11    | 94            |
| 8:05 AM                         | 2                      | 1    | 1     | 0 | 2                      | 1    | 0     | 0 | 0                        | 0    | 7     | 0 | 0                        | 1    | 0     | 0 | 15    | 102           |
| 8:10 AM                         | 0                      | 3    | 1     | 0 | 4                      | 5    | 0     | 0 | 0                        | 0    | 4     | 1 | 0                        | 1    | 2     | 0 | 21    | 121           |
| 8:15 AM                         | 0                      | 0    | 1     | 0 | 2                      | 1    | 0     | 0 | 0                        | 0    | 2     | 0 | 0                        | 0    | 0     | 0 | 6     | 122           |
| 8:20 AM                         | 0                      | 0    | 0     | 0 | 1                      | 1    | 0     | 0 | 0                        | 0    | 5     | 0 | 0                        | 0    | 1     | 0 | 8     | 126           |
| 8:25 AM                         | 0                      | 1    | 0     | 0 | 0                      | 0    | 0     | 0 | 0                        | 0    | 3     | 0 | 0                        | 0    | 3     | 0 | 7     | 130           |
| 8:30 AM                         | 1                      | 1    | 0     | 0 | 0                      | 0    | 0     | 0 | 0                        | 0    | 7     | 0 | 0                        | 1    | 0     | 0 | 10    | 133           |
| 8:35 AM                         | 0                      | 0    | 0     | 0 | 1                      | 0    | 0     | 0 | 0                        | 0    | 3     | 0 | 0                        | 0    | 1     | 0 | 5     | 136           |
| 8:40 AM                         | 0                      | 0    | 0     | 0 | 0                      | 1    | 0     | 0 | 0                        | 0    | 3     | 0 | 0                        | 0    | 3     | 0 | 7     | 130           |
| 8:45 AM                         | 0                      | 0    | 0     | 0 | 0                      | 0    | 0     | 0 | 0                        | 0    | 1     | 0 | 0                        | 0    | 1     | 0 | 2     | 122           |
| 8:50 AM                         | 0                      | 1    | 0     | 0 | 0                      | 0    | 0     | 0 | 0                        | 0    | 0     | 0 | 0                        | 0    | 2     | 0 | 3     | 110           |
| 8:55 AM                         | 0                      | 0    | 1     | 0 | 0                      | 0    | 0     | 0 | 0                        | 0    | 1     | 0 | 0                        | 0    | 0     | 0 | 2     | 97            |
| 9:00 AM                         | 0                      | 0    | 1     | 0 | 0                      | 1    | 0     | 0 | 0                        | 0    | 1     | 0 | 0                        | 1    | 1     | 0 | 5     | 91            |
| 9:05 AM                         | 0                      | 0    | 1     | 0 | 1                      | 0    | 0     | 0 | 0                        | 0    | 1     | 0 | 0                        | 0    | 1     | 0 | 4     | 80            |

Attachment B

| 5-Min Count<br>Period<br>Beginning At | Donnis Rd<br>(Northbound) |      |       |   | Donnis Rd<br>(Southbound) |      |       |   | Quail Run Rd<br>(Eastbound) |      |       |   | Quail Run Rd<br>(Westbound) |      |       |   | Total | Hourly<br>Totals |
|---------------------------------------|---------------------------|------|-------|---|---------------------------|------|-------|---|-----------------------------|------|-------|---|-----------------------------|------|-------|---|-------|------------------|
|                                       | Left                      | Thru | Right | U | Left                      | Thru | Right | U | Left                        | Thru | Right | U | Left                        | Thru | Right | U |       |                  |
| 9:10 AM                               | 0                         | 0    | 0     | 0 | 2                         | 0    | 0     | 0 | 0                           | 2    | 0     | 0 | 1                           | 0    | 0     | 0 | 5     | 64               |
| 9:15 AM                               | 0                         | 0    | 0     | 0 | 0                         | 0    | 0     | 0 | 0                           | 0    | 1     | 0 | 0                           | 0    | 0     | 0 | 1     | 59               |
| 9:20 AM                               | 0                         | 0    | 0     | 0 | 1                         | 1    | 0     | 0 | 0                           | 0    | 2     | 0 | 0                           | 0    | 1     | 0 | 5     | 56               |
| 9:25 AM                               | 0                         | 0    | 0     | 0 | 0                         | 0    | 0     | 0 | 0                           | 0    | 1     | 0 | 0                           | 0    | 0     | 1 | 2     | 51               |
| 9:30 AM                               | 0                         | 0    | 0     | 0 | 0                         | 0    | 0     | 0 | 0                           | 0    | 0     | 0 | 1                           | 3    | 0     | 0 | 4     | 45               |
| 9:35 AM                               | 0                         | 0    | 0     | 0 | 0                         | 0    | 0     | 0 | 0                           | 0    | 2     | 0 | 0                           | 1    | 0     | 0 | 3     | 43               |
| 9:40 AM                               | 0                         | 1    | 0     | 0 | 0                         | 1    | 0     | 0 | 0                           | 0    | 4     | 0 | 0                           | 0    | 1     | 0 | 7     | 43               |
| 9:45 AM                               | 0                         | 1    | 1     | 0 | 0                         | 0    | 0     | 0 | 0                           | 0    | 2     | 0 | 0                           | 0    | 0     | 2 | 6     | 47               |
| 9:50 AM                               | 0                         | 0    | 0     | 0 | 0                         | 1    | 0     | 0 | 0                           | 0    | 2     | 0 | 0                           | 0    | 2     | 0 | 5     | 49               |
| 9:55 AM                               | 0                         | 0    | 0     | 0 | 0                         | 0    | 0     | 0 | 0                           | 0    | 1     | 0 | 0                           | 0    | 3     | 0 | 4     | 51               |
| 10:00 AM                              | 0                         | 0    | 1     | 0 | 0                         | 0    | 0     | 0 | 0                           | 0    | 8     | 0 | 0                           | 0    | 1     | 0 | 10    | 56               |
| 10:05 AM                              | 0                         | 1    | 0     | 0 | 1                         | 2    | 0     | 0 | 0                           | 0    | 1     | 0 | 0                           | 0    | 0     | 0 | 5     | 57               |
| 10:10 AM                              | 0                         | 0    | 1     | 0 | 0                         | 1    | 0     | 0 | 0                           | 0    | 1     | 0 | 0                           | 0    | 1     | 1 | 5     | 57               |
| 10:15 AM                              | 0                         | 0    | 0     | 0 | 0                         | 0    | 0     | 0 | 0                           | 0    | 1     | 1 | 0                           | 0    | 1     | 0 | 3     | 59               |
| 10:20 AM                              | 0                         | 1    | 0     | 0 | 0                         | 0    | 0     | 0 | 0                           | 0    | 2     | 0 | 0                           | 0    | 2     | 0 | 5     | 59               |
| 10:25 AM                              | 0                         | 0    | 0     | 0 | 0                         | 0    | 0     | 0 | 0                           | 0    | 2     | 0 | 0                           | 0    | 2     | 0 | 4     | 61               |
| 10:30 AM                              | 0                         | 0    | 0     | 0 | 0                         | 2    | 0     | 0 | 0                           | 0    | 2     | 0 | 0                           | 0    | 2     | 0 | 6     | 63               |
| 10:35 AM                              | 0                         | 0    | 0     | 0 | 0                         | 0    | 0     | 0 | 0                           | 0    | 4     | 0 | 0                           | 1    | 1     | 0 | 6     | 66               |
| 10:40 AM                              | 1                         | 1    | 0     | 0 | 0                         | 1    | 0     | 0 | 0                           | 0    | 0     | 0 | 0                           | 0    | 1     | 0 | 4     | 63               |
| 10:45 AM                              | 0                         | 0    | 0     | 0 | 1                         | 1    | 0     | 0 | 0                           | 0    | 5     | 0 | 0                           | 0    | 1     | 0 | 8     | 65               |
| 10:50 AM                              | 0                         | 0    | 0     | 0 | 0                         | 0    | 0     | 0 | 0                           | 0    | 6     | 1 | 0                           | 0    | 1     | 0 | 8     | 68               |
| 10:55 AM                              | 0                         | 0    | 0     | 0 | 1                         | 0    | 0     | 0 | 0                           | 0    | 1     | 0 | 0                           | 0    | 2     | 0 | 4     | 68               |
| 11:00 AM                              | 0                         | 0    | 0     | 0 | 0                         | 0    | 0     | 0 | 0                           | 0    | 2     | 0 | 0                           | 0    | 3     | 0 | 5     | 63               |
| 11:05 AM                              | 0                         | 0    | 0     | 0 | 1                         | 0    | 0     | 0 | 0                           | 0    | 2     | 0 | 0                           | 1    | 0     | 0 | 4     | 62               |
| 11:10 AM                              | 1                         | 0    | 0     | 0 | 1                         | 0    | 0     | 0 | 0                           | 0    | 0     | 0 | 0                           | 0    | 1     | 0 | 3     | 60               |
| 11:15 AM                              | 0                         | 0    | 0     | 0 | 0                         | 0    | 0     | 0 | 0                           | 0    | 2     | 0 | 0                           | 2    | 1     | 1 | 6     | 63               |
| 11:20 AM                              | 0                         | 0    | 0     | 0 | 0                         | 1    | 1     | 0 | 0                           | 0    | 2     | 0 | 0                           | 1    | 2     | 0 | 7     | 65               |
| 11:25 AM                              | 0                         | 0    | 0     | 0 | 0                         | 0    | 0     | 0 | 0                           | 0    | 1     | 0 | 0                           | 0    | 0     | 0 | 1     | 62               |
| 11:30 AM                              | 0                         | 0    | 0     | 0 | 0                         | 0    | 0     | 0 | 0                           | 0    | 2     | 0 | 0                           | 0    | 2     | 0 | 4     | 60               |
| 11:35 AM                              | 0                         | 0    | 0     | 0 | 0                         | 0    | 0     | 0 | 0                           | 0    | 1     | 0 | 0                           | 0    | 2     | 1 | 4     | 58               |
| 11:40 AM                              | 0                         | 0    | 0     | 0 | 0                         | 0    | 1     | 0 | 0                           | 0    | 3     | 0 | 0                           | 0    | 2     | 0 | 6     | 60               |
| 11:45 AM                              | 0                         | 1    | 1     | 0 | 1                         | 0    | 0     | 0 | 0                           | 0    | 1     | 0 | 0                           | 0    | 0     | 0 | 4     | 56               |
| 11:50 AM                              | 0                         | 2    | 0     | 0 | 0                         | 1    | 0     | 0 | 0                           | 0    | 1     | 0 | 0                           | 0    | 1     | 0 | 5     | 53               |
| 11:55 AM                              | 0                         | 0    | 0     | 0 | 0                         | 0    | 0     | 0 | 0                           | 0    | 2     | 0 | 0                           | 0    | 2     | 0 | 4     | 53               |
| 12:00 PM                              | 0                         | 0    | 1     | 0 | 0                         | 1    | 1     | 0 | 0                           | 0    | 1     | 0 | 0                           | 0    | 5     | 0 | 9     | 57               |
| 12:05 PM                              | 0                         | 0    | 0     | 0 | 0                         | 0    | 0     | 0 | 0                           | 0    | 2     | 0 | 0                           | 0    | 2     | 0 | 4     | 57               |
| 12:10 PM                              | 0                         | 2    | 0     | 0 | 0                         | 1    | 0     | 0 | 0                           | 0    | 3     | 0 | 0                           | 1    | 2     | 0 | 9     | 63               |
| 12:15 PM                              | 0                         | 0    | 1     | 0 | 0                         | 0    | 0     | 0 | 0                           | 0    | 3     | 0 | 0                           | 0    | 2     | 0 | 6     | 63               |
| 12:20 PM                              | 0                         | 0    | 0     | 0 | 1                         | 0    | 0     | 0 | 0                           | 0    | 3     | 0 | 0                           | 1    | 1     | 0 | 6     | 62               |
| 12:25 PM                              | 0                         | 0    | 0     | 0 | 0                         | 1    | 0     | 0 | 0                           | 0    | 1     | 0 | 0                           | 0    | 0     | 0 | 2     | 63               |
| 12:30 PM                              | 0                         | 0    | 0     | 0 | 1                         | 2    | 0     | 0 | 0                           | 0    | 2     | 0 | 0                           | 0    | 1     | 0 | 6     | 65               |
| 12:35 PM                              | 0                         | 0    | 0     | 0 | 0                         | 0    | 1     | 0 | 0                           | 0    | 4     | 0 | 0                           | 0    | 2     | 0 | 7     | 68               |
| 12:40 PM                              | 0                         | 0    | 0     | 0 | 0                         | 0    | 0     | 0 | 0                           | 0    | 1     | 0 | 0                           | 0    | 2     | 0 | 3     | 65               |
| 12:45 PM                              | 0                         | 1    | 0     | 0 | 0                         | 0    | 0     | 0 | 0                           | 0    | 2     | 1 | 0                           | 1    | 1     | 0 | 6     | 67               |
| 12:50 PM                              | 0                         | 0    | 0     | 0 | 0                         | 0    | 0     | 0 | 0                           | 0    | 3     | 0 | 0                           | 0    | 2     | 0 | 5     | 67               |
| 12:55 PM                              | 1                         | 0    | 0     | 0 | 0                         | 0    | 0     | 0 | 0                           | 0    | 0     | 0 | 0                           | 1    | 1     | 0 | 3     | 66               |
| 1:00 PM                               | 0                         | 0    | 0     | 0 | 0                         | 0    | 0     | 0 | 0                           | 0    | 2     | 0 | 0                           | 0    | 0     | 0 | 2     | 59               |
| 1:05 PM                               | 1                         | 0    | 0     | 0 | 0                         | 0    | 0     | 0 | 0                           | 0    | 1     | 1 | 0                           | 1    | 2     | 0 | 6     | 61               |
| 1:10 PM                               | 0                         | 0    | 0     | 0 | 0                         | 1    | 0     | 0 | 0                           | 0    | 2     | 0 | 0                           | 0    | 1     | 0 | 4     | 56               |
| 1:15 PM                               | 0                         | 0    | 2     | 0 | 0                         | 0    | 0     | 0 | 0                           | 0    | 1     | 1 | 0                           | 0    | 0     | 0 | 4     | 54               |
| 1:20 PM                               | 0                         | 0    | 1     | 0 | 0                         | 0    | 0     | 0 | 0                           | 0    | 2     | 0 | 0                           | 0    | 2     | 0 | 5     | 53               |
| 1:25 PM                               | 0                         | 0    | 0     | 0 | 1                         | 0    | 0     | 0 | 0                           | 0    | 2     | 0 | 0                           | 0    | 2     | 0 | 5     | 56               |
| 1:30 PM                               | 0                         | 0    | 0     | 0 | 1                         | 1    | 0     | 0 | 0                           | 0    | 3     | 0 | 0                           | 0    | 4     | 0 | 9     | 59               |
| 1:35 PM                               | 0                         | 1    | 0     | 0 | 2                         | 0    | 0     | 0 | 0                           | 0    | 5     | 0 | 0                           | 0    | 1     | 0 | 9     | 61               |
| 1:40 PM                               | 0                         | 1    | 0     | 0 | 0                         | 0    | 0     | 0 | 0                           | 0    | 1     | 0 | 0                           | 0    | 0     | 0 | 2     | 60               |
| 1:45 PM                               | 0                         | 0    | 0     | 0 | 0                         | 0    | 0     | 0 | 0                           | 0    | 1     | 0 | 0                           | 1    | 1     | 0 | 3     | 57               |
| 1:50 PM                               | 0                         | 1    | 0     | 0 | 0                         | 1    | 0     | 0 | 0                           | 0    | 1     | 0 | 0                           | 0    | 0     | 0 | 3     | 55               |
| 1:55 PM                               | 0                         | 0    | 0     | 0 | 0                         | 0    | 0     | 0 | 0                           | 0    | 2     | 0 | 0                           | 0    | 1     | 0 | 3     | 55               |
| 2:00 PM                               | 0                         | 0    | 0     | 0 | 0                         | 0    | 0     | 0 | 0                           | 0    | 0     | 0 | 0                           | 0    | 0     | 0 | 0     | 53               |
| 2:05 PM                               | 0                         | 0    | 0     | 0 | 2                         | 2    | 0     | 0 | 0                           | 0    | 3     | 0 | 0                           | 0    | 2     | 0 | 9     | 56               |
| 2:10 PM                               | 0                         | 0    | 0     | 0 | 0                         | 1    | 0     | 0 | 1                           | 1    | 2     | 0 | 0                           | 1    | 2     | 1 | 8     | 60               |
| 2:15 PM                               | 0                         | 0    | 0     | 0 | 1                         | 0    | 1     | 0 | 2                           | 2    | 1     | 0 | 0                           | 0    | 0     | 0 | 5     | 61               |
| 2:20 PM                               | 0                         | 2    | 1     | 0 | 0                         | 0    | 1     | 0 | 0                           | 0    | 0     | 0 | 0                           | 1    | 3     | 0 | 8     | 64               |
| 2:25 PM                               | 0                         | 0    | 0     | 0 | 0                         | 1    | 0     | 0 | 0                           | 0    | 3     | 0 | 0                           | 3    | 2     | 0 | 9     | 68               |
| 2:30 PM                               | 0                         | 0    | 0     | 0 | 0                         | 0    | 0     | 0 | 0                           | 0    | 2     | 0 | 0                           | 1    | 2     | 0 | 5     | 64               |
| 2:35 PM                               | 0                         | 0    | 0     | 0 | 0                         | 0    | 1     | 0 | 0                           | 0    | 3     | 0 | 0                           | 0    | 2     | 0 | 6     | 61               |
| 2:40 PM                               | 0                         | 0    | 0     | 0 | 0                         | 2    | 0     | 0 | 0                           | 0    | 3     | 0 | 0                           | 5    | 6     | 1 | 17    | 76               |
| 2:45 PM                               | 0                         | 0    | 0     | 0 | 0                         | 0    | 0     | 0 | 0                           | 0    | 5     | 0 | 0                           | 0    | 3     | 0 | 8     | 81               |
| 2:50 PM                               | 1                         | 1    | 0     | 0 | 1                         | 0    | 0     | 0 | 0                           | 0    | 0     | 1 | 0                           | 1    | 3     | 0 | 8     | 86               |
| 2:55 PM                               | 0                         | 1    | 0     | 0 | 1                         | 1    | 0     | 0 | 0                           | 0    | 4     | 0 | 0                           | 1    | 1     | 0 | 9     | 92               |
| 3:00 PM                               | 0                         | 0    | 0     | 0 | 1                         | 0    | 0     | 0 | 0                           | 0    | 1     | 0 | 0                           | 0    | 4     | 1 | 7     | 99               |
| 3:05 PM                               | 0                         | 0    | 0     | 0 | 0                         | 1    | 0     | 0 | 0                           | 0    | 1     | 0 | 0                           | 0    | 1     | 0 | 3     | 93               |
| 3:10 PM                               | 0                         | 0    | 0     | 0 | 0                         | 0    | 0     | 0 | 0                           | 0    | 3     | 0 | 0                           | 0    | 3     | 0 | 6     | 91               |
| 3:15 PM                               | 0                         | 3    | 0     | 0 | 0                         | 0    | 0     | 0 | 1                           | 1    | 1     | 0 | 0                           | 0    | 0     | 0 | 5     | 91               |
| 3:20 PM                               | 0                         | 0    | 0     | 0 | 0                         | 0    | 0     | 0 | 0                           | 0    | 1     | 0 | 0                           | 0    | 0     | 0 | 1     | 84               |
| 3:25 PM                               | 0                         | 0    | 0     | 0 | 0                         | 0    | 0     | 0 | 0                           | 0    | 0     | 0 | 0                           | 1    | 1     | 0 | 2     | 77               |
| 3:30 PM                               | 0                         | 2    | 0     | 0 | 0                         | 0    | 0     | 0 | 0                           | 0    | 1     | 0 | 0                           | 0    | 3     | 1 | 7     | 79               |
| 3:35 PM                               | 0                         | 0    | 1     | 0 | 1                         | 0    | 0     | 0 | 0                           | 0    | 1     | 0 | 0                           | 2    | 4     | 0 | 9     | 82               |
| 3:40 PM                               | 0                         | 1    | 0     | 0 | 2                         | 2    | 0     | 0 | 0                           | 0    | 3     | 0 | 0                           | 1    | 3     | 0 | 12    | 77               |
| 3:45 PM                               | 1                         | 1    | 0     | 0 | 0                         | 2    | 0     | 0 | 0                           | 0    | 1     | 0 | 0                           | 2    | 0     | 0 | 7     | 76               |
| 3:50 PM                               | 1                         | 0    | 0     | 0 | 1                         | 0    | 0     | 0 | 0                           | 0    | 4     | 0 | 0                           | 0    | 2     | 0 | 8     | 76               |
| 3:55 PM                               | 0                         | 0    | 1     | 0 | 0                         | 0    | 0     | 0 | 0                           | 0    | 0     | 0 | 0                           | 0    | 2     | 1 | 4     | 71               |
| 4:00 PM                               | 1                         | 1    | 0     | 0 | 0                         | 0    | 0     | 0 | 0                           | 0    | 1     | 0 | 0                           | 1    | 4     | 0 | 8     | 72               |
| 4:05 PM                               | 1                         | 1    | 0     | 0 | 0                         | 1    | 0     | 0 | 0                           | 0    | 5     | 0 | 0                           | 0    | 0     | 0 | 8     | 77               |
| 4:10 PM                               | 0                         | 0    | 1     | 0 | 0                         | 1    | 0     | 0 | 0                           | 0    | 3     | 0 | 0                           | 1    | 3     | 0 | 9     | 80               |
| 4:15 PM                               | 0                         | 0    | 0     | 0 | 1                         | 1    | 0     | 0 | 0                           | 0    | 1     | 0 | 0                           | 0    | 2     | 0 | 5     | 80               |
| 4:20 PM                               | 0                         | 0    | 0     | 0 | 0                         | 1    | 0     | 0 | 0                           | 0    | 3     | 1 | 0                           | 0    | 1     | 0 | 6     | 85               |
| 4:25 PM                               | 0                         | 1    | 3     | 0 | 0                         | 0    | 0     | 0 | 0                           | 0    | 2     | 0 | 0                           | 6    | 2     | 1 | 15    | 98               |
| 4:30 PM                               | 0                         | 0    | 1     | 0 | 0                         | 0    | 0     | 0 | 0                           | 0    | 1     | 0 | 0                           | 1    | 2     | 0 | 5     | 96               |

## Attachment B

| 5-Min Count Period Beginning At | Donnis Rd (Northbound) |      |       |   | Donnis Rd (Southbound) |      |       |   | Quail Run Rd (Eastbound) |      |       |   | Quail Run Rd (Westbound) |      |       |   | Total | Hourly Totals |
|---------------------------------|------------------------|------|-------|---|------------------------|------|-------|---|--------------------------|------|-------|---|--------------------------|------|-------|---|-------|---------------|
|                                 | Left                   | Thru | Right | U | Left                   | Thru | Right | U | Left                     | Thru | Right | U | Left                     | Thru | Right | U |       |               |
| 4:35 PM                         | 0                      | 0    | 2     | 0 | 0                      | 0    | 0     | 0 | 1                        | 1    | 1     | 0 | 1                        | 2    | 0     | 0 | 8     | 95            |
| 4:40 PM                         | 0                      | 3    | 2     | 0 | 0                      | 0    | 0     | 0 | 0                        | 2    | 0     | 0 | 0                        | 3    | 0     | 0 | 10    | 93            |
| 4:45 PM                         | 0                      | 0    | 1     | 0 | 2                      | 3    | 1     | 0 | 0                        | 1    | 0     | 0 | 2                        | 3    | 1     | 0 | 14    | 100           |
| 4:50 PM                         | 0                      | 1    | 0     | 0 | 0                      | 1    | 1     | 0 | 0                        | 4    | 0     | 0 | 5                        | 4    | 0     | 0 | 16    | 108           |
| 4:55 PM                         | 0                      | 0    | 0     | 0 | 0                      | 0    | 0     | 0 | 0                        | 3    | 0     | 0 | 1                        | 2    | 0     | 0 | 6     | 110           |
| 5:00 PM                         | 1                      | 2    | 0     | 0 | 0                      | 1    | 0     | 0 | 0                        | 1    | 0     | 0 | 1                        | 3    | 0     | 0 | 9     | 111           |
| 5:05 PM                         | 1                      | 0    | 0     | 0 | 0                      | 0    | 0     | 0 | 0                        | 0    | 0     | 0 | 2                        | 3    | 0     | 0 | 6     | 109           |
| 5:10 PM                         | 0                      | 0    | 0     | 0 | 1                      | 3    | 0     | 0 | 0                        | 1    | 0     | 0 | 2                        | 0    | 0     | 0 | 7     | 107           |
| 5:15 PM                         | 0                      | 0    | 0     | 0 | 0                      | 1    | 0     | 0 | 0                        | 1    | 0     | 0 | 2                        | 2    | 0     | 0 | 6     | 108           |
| 5:20 PM                         | 0                      | 0    | 0     | 0 | 0                      | 0    | 0     | 0 | 0                        | 3    | 1     | 0 | 0                        | 1    | 0     | 0 | 5     | 107           |
| 5:25 PM                         | 1                      | 1    | 1     | 0 | 0                      | 0    | 0     | 0 | 0                        | 3    | 0     | 0 | 0                        | 4    | 0     | 0 | 10    | 102           |
| 5:30 PM                         | 0                      | 0    | 0     | 0 | 0                      | 0    | 1     | 0 | 0                        | 1    | 0     | 0 | 1                        | 3    | 0     | 0 | 6     | 103           |
| 5:35 PM                         | 0                      | 1    | 0     | 0 | 0                      | 0    | 0     | 0 | 0                        | 1    | 0     | 0 | 0                        | 3    | 0     | 0 | 5     | 100           |
| 5:40 PM                         | 0                      | 0    | 0     | 0 | 1                      | 0    | 0     | 0 | 0                        | 0    | 0     | 0 | 0                        | 1    | 0     | 0 | 2     | 92            |
| 5:45 PM                         | 0                      | 0    | 0     | 0 | 0                      | 0    | 0     | 0 | 0                        | 1    | 0     | 0 | 0                        | 2    | 0     | 0 | 3     | 81            |
| 5:50 PM                         | 1                      | 0    | 0     | 0 | 0                      | 0    | 1     | 0 | 0                        | 2    | 0     | 0 | 1                        | 4    | 0     | 0 | 9     | 74            |
| 5:55 PM                         | 0                      | 1    | 0     | 0 | 0                      | 0    | 0     | 0 | 0                        | 2    | 0     | 0 | 0                        | 3    | 0     | 0 | 6     | 74            |
| 6:00 PM                         | 0                      | 0    | 1     | 0 | 1                      | 0    | 0     | 0 | 0                        | 1    | 0     | 0 | 0                        | 1    | 0     | 0 | 4     | 69            |
| 6:05 PM                         | 0                      | 0    | 0     | 0 | 1                      | 0    | 0     | 0 | 0                        | 1    | 0     | 0 | 0                        | 4    | 0     | 0 | 6     | 69            |
| 6:10 PM                         | 0                      | 1    | 1     | 0 | 0                      | 0    | 0     | 0 | 0                        | 2    | 0     | 0 | 0                        | 2    | 0     | 0 | 6     | 68            |
| 6:15 PM                         | 0                      | 0    | 0     | 0 | 0                      | 0    | 0     | 0 | 0                        | 1    | 0     | 0 | 0                        | 1    | 1     | 0 | 3     | 65            |
| 6:20 PM                         | 1                      | 0    | 0     | 0 | 0                      | 0    | 0     | 0 | 0                        | 3    | 1     | 0 | 1                        | 1    | 0     | 0 | 7     | 67            |
| 6:25 PM                         | 0                      | 0    | 0     | 0 | 0                      | 1    | 0     | 0 | 0                        | 2    | 0     | 0 | 0                        | 4    | 0     | 0 | 7     | 64            |
| 6:30 PM                         | 0                      | 0    | 0     | 0 | 1                      | 0    | 0     | 0 | 0                        | 0    | 1     | 0 | 0                        | 2    | 0     | 0 | 4     | 62            |
| 6:35 PM                         | 0                      | 1    | 0     | 0 | 2                      | 0    | 0     | 0 | 0                        | 1    | 0     | 0 | 0                        | 3    | 1     | 0 | 8     | 65            |
| 6:40 PM                         | 0                      | 2    | 0     | 0 | 0                      | 0    | 0     | 0 | 0                        | 2    | 0     | 0 | 0                        | 1    | 0     | 0 | 5     | 68            |
| 6:45 PM                         | 0                      | 0    | 1     | 0 | 0                      | 0    | 0     | 0 | 0                        | 1    | 0     | 0 | 0                        | 4    | 0     | 0 | 6     | 71            |
| 6:50 PM                         | 1                      | 0    | 0     | 0 | 0                      | 0    | 0     | 0 | 0                        | 0    | 0     | 0 | 0                        | 2    | 0     | 0 | 3     | 65            |
| 6:55 PM                         | 1                      | 0    | 0     | 0 | 0                      | 0    | 0     | 0 | 0                        | 0    | 0     | 0 | 1                        | 1    | 0     | 0 | 3     | 62            |
| 7:00 PM                         | 0                      | 0    | 0     | 0 | 1                      | 0    | 0     | 0 | 0                        | 3    | 0     | 0 | 0                        | 2    | 1     | 0 | 7     | 65            |
| 7:05 PM                         | 0                      | 0    | 0     | 0 | 0                      | 0    | 0     | 0 | 0                        | 1    | 0     | 0 | 0                        | 3    | 0     | 0 | 4     | 63            |
| 7:10 PM                         | 0                      | 0    | 0     | 0 | 0                      | 0    | 0     | 0 | 0                        | 3    | 0     | 0 | 0                        | 1    | 0     | 0 | 4     | 61            |
| 7:15 PM                         | 0                      | 0    | 0     | 0 | 0                      | 0    | 0     | 0 | 0                        | 2    | 0     | 0 | 0                        | 2    | 0     | 0 | 4     | 62            |
| 7:20 PM                         | 0                      | 0    | 0     | 0 | 0                      | 0    | 0     | 0 | 0                        | 0    | 0     | 0 | 0                        | 1    | 0     | 0 | 1     | 56            |
| 7:25 PM                         | 0                      | 0    | 0     | 0 | 0                      | 0    | 0     | 0 | 0                        | 1    | 0     | 0 | 0                        | 2    | 0     | 0 | 3     | 52            |
| 7:30 PM                         | 0                      | 1    | 0     | 0 | 0                      | 0    | 0     | 0 | 0                        | 0    | 0     | 0 | 0                        | 3    | 0     | 0 | 4     | 52            |
| 7:35 PM                         | 0                      | 0    | 0     | 0 | 0                      | 0    | 0     | 0 | 0                        | 3    | 0     | 0 | 0                        | 1    | 0     | 0 | 4     | 48            |
| 7:40 PM                         | 0                      | 0    | 0     | 0 | 0                      | 0    | 0     | 0 | 0                        | 0    | 0     | 0 | 0                        | 1    | 0     | 0 | 1     | 44            |
| 7:45 PM                         | 0                      | 0    | 0     | 0 | 0                      | 0    | 0     | 0 | 0                        | 0    | 0     | 0 | 0                        | 3    | 0     | 0 | 3     | 41            |
| 7:50 PM                         | 0                      | 0    | 0     | 0 | 0                      | 0    | 0     | 0 | 0                        | 0    | 0     | 0 | 0                        | 1    | 0     | 0 | 1     | 39            |
| 7:55 PM                         | 0                      | 0    | 0     | 0 | 0                      | 0    | 0     | 0 | 0                        | 0    | 0     | 0 | 0                        | 0    | 0     | 0 | 0     | 36            |
| 8:00 PM                         | 0                      | 0    | 0     | 0 | 0                      | 0    | 0     | 0 | 0                        | 0    | 0     | 0 | 0                        | 1    | 0     | 0 | 1     | 30            |
| 8:05 PM                         | 0                      | 1    | 0     | 0 | 0                      | 0    | 0     | 0 | 0                        | 0    | 0     | 0 | 0                        | 1    | 0     | 0 | 2     | 28            |
| 8:10 PM                         | 0                      | 0    | 0     | 0 | 0                      | 0    | 0     | 0 | 0                        | 0    | 0     | 0 | 0                        | 3    | 1     | 0 | 4     | 28            |
| 8:15 PM                         | 0                      | 1    | 0     | 0 | 0                      | 1    | 0     | 0 | 0                        | 0    | 1     | 0 | 0                        | 1    | 0     | 0 | 4     | 28            |
| 8:20 PM                         | 0                      | 0    | 0     | 0 | 0                      | 0    | 0     | 0 | 0                        | 0    | 0     | 0 | 0                        | 5    | 0     | 0 | 5     | 32            |
| 8:25 PM                         | 0                      | 0    | 0     | 0 | 0                      | 0    | 0     | 0 | 0                        | 2    | 0     | 0 | 0                        | 0    | 1     | 0 | 3     | 32            |
| 8:30 PM                         | 0                      | 0    | 0     | 0 | 0                      | 0    | 0     | 0 | 0                        | 1    | 0     | 0 | 0                        | 2    | 0     | 0 | 3     | 31            |
| 8:35 PM                         | 1                      | 0    | 0     | 0 | 0                      | 0    | 1     | 0 | 0                        | 1    | 0     | 0 | 0                        | 1    | 0     | 0 | 4     | 31            |
| 8:40 PM                         | 0                      | 0    | 0     | 0 | 0                      | 0    | 0     | 0 | 0                        | 0    | 0     | 0 | 0                        | 0    | 0     | 0 | 0     | 30            |
| 8:45 PM                         | 1                      | 0    | 0     | 0 | 0                      | 0    | 0     | 0 | 0                        | 1    | 0     | 0 | 1                        | 0    | 0     | 0 | 3     | 30            |
| 8:50 PM                         | 0                      | 0    | 0     | 0 | 0                      | 0    | 0     | 0 | 0                        | 2    | 0     | 0 | 0                        | 1    | 0     | 0 | 3     | 32            |
| 8:55 PM                         | 1                      | 0    | 0     | 0 | 0                      | 0    | 0     | 0 | 0                        | 0    | 0     | 0 | 0                        | 1    | 0     | 0 | 2     | 34            |
| 9:00 PM                         | 0                      | 0    | 1     | 0 | 0                      | 0    | 0     | 0 | 0                        | 0    | 0     | 0 | 0                        | 0    | 0     | 0 | 1     | 34            |
| 9:05 PM                         | 2                      | 0    | 0     | 0 | 0                      | 0    | 0     | 0 | 0                        | 1    | 0     | 0 | 0                        | 1    | 0     | 0 | 4     | 36            |
| 9:10 PM                         | 0                      | 0    | 0     | 0 | 0                      | 0    | 0     | 0 | 0                        | 1    | 0     | 0 | 1                        | 0    | 0     | 0 | 2     | 34            |
| 9:15 PM                         | 0                      | 0    | 0     | 0 | 0                      | 1    | 0     | 0 | 0                        | 1    | 0     | 0 | 0                        | 1    | 0     | 0 | 3     | 33            |
| 9:20 PM                         | 0                      | 0    | 0     | 0 | 0                      | 0    | 0     | 0 | 0                        | 0    | 0     | 0 | 0                        | 1    | 0     | 0 | 1     | 29            |
| 9:25 PM                         | 0                      | 1    | 0     | 0 | 0                      | 0    | 0     | 0 | 0                        | 0    | 0     | 0 | 0                        | 0    | 0     | 0 | 1     | 27            |
| 9:30 PM                         | 0                      | 0    | 0     | 0 | 0                      | 0    | 0     | 0 | 0                        | 0    | 0     | 0 | 0                        | 0    | 0     | 0 | 0     | 24            |
| 9:35 PM                         | 1                      | 1    | 0     | 0 | 0                      | 0    | 0     | 0 | 0                        | 0    | 0     | 0 | 1                        | 0    | 0     | 0 | 3     | 23            |
| 9:40 PM                         | 0                      | 0    | 0     | 0 | 0                      | 0    | 0     | 0 | 0                        | 0    | 0     | 0 | 0                        | 0    | 0     | 0 | 0     | 23            |
| 9:45 PM                         | 1                      | 0    | 0     | 0 | 0                      | 0    | 0     | 0 | 0                        | 1    | 0     | 0 | 0                        | 1    | 0     | 0 | 3     | 23            |
| 9:50 PM                         | 0                      | 0    | 0     | 0 | 0                      | 0    | 0     | 0 | 0                        | 0    | 0     | 0 | 1                        | 0    | 0     | 0 | 1     | 21            |
| 9:55 PM                         | 0                      | 0    | 0     | 0 | 0                      | 0    | 0     | 0 | 0                        | 0    | 0     | 0 | 0                        | 2    | 0     | 0 | 2     | 21            |
| Peak 15-Min Flowrates           | Northbound             |      |       |   | Southbound             |      |       |   | Eastbound                |      |       |   | Westbound                |      |       |   | Total |               |
|                                 | Left                   | Thru | Right | U | Left                   | Thru | Right | U | Left                     | Thru | Right | U | Left                     | Thru | Right | U |       |               |
| All Vehicles                    | 8                      | 20   | 12    | 0 | 32                     | 24   | 0     | 0 | 0                        | 60   | 4     | 0 | 16                       | 12   | 0     | 0 | 188   |               |
| Heavy Trucks                    | 0                      | 0    | 0     |   | 0                      | 0    | 0     |   | 0                        | 4    | 0     |   | 0                        | 0    | 0     |   | 4     |               |
| Buses                           |                        |      |       |   |                        |      |       |   |                          |      |       |   |                          |      |       |   |       |               |
| Pedestrians                     |                        | 4    |       |   |                        | 0    |       |   |                          | 8    |       |   |                          | 0    |       |   | 12    |               |
| Bicycles                        | 0                      | 0    | 4     |   | 0                      | 4    | 0     |   | 0                        | 0    | 0     |   | 0                        | 0    | 4     |   | 12    |               |
| Scoters                         |                        |      |       |   |                        |      |       |   |                          |      |       |   |                          |      |       |   |       |               |

Comments:

LOCATION: Donnis Rd -- Donnie Ann Rd  
 CITY/STATE: Rossmore, CA

QC JOB #: 16966421  
 DATE: Wed, Apr 9 2025

Peak-Hour: 7:40 AM -- 8:40 AM  
 Peak 15-Min: 7:40 AM -- 7:55 AM

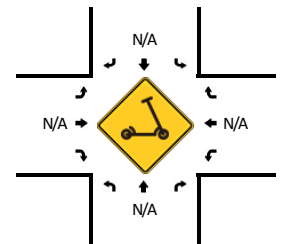
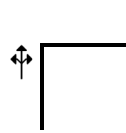
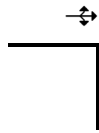
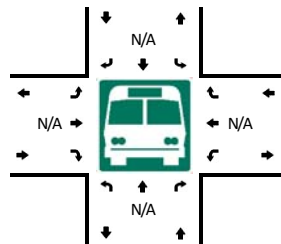
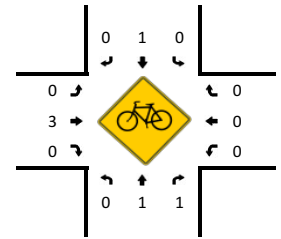
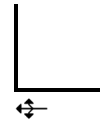
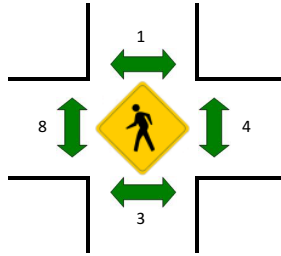
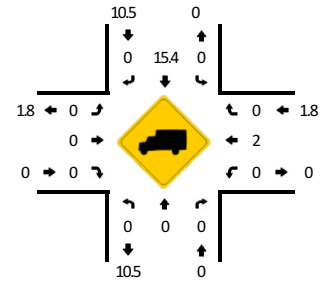
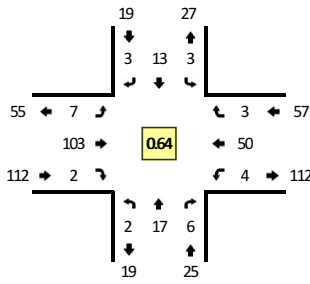

| 5-Min Count Period Beginning At | Donnis Rd (Northbound) |      |       |   | Donnis Rd (Southbound) |      |       |   | Donnie Ann Rd (Eastbound) |      |       |   | Donnie Ann Rd (Westbound) |      |       |   | Total | Hourly Totals |     |
|---------------------------------|------------------------|------|-------|---|------------------------|------|-------|---|---------------------------|------|-------|---|---------------------------|------|-------|---|-------|---------------|-----|
|                                 | Left                   | Thru | Right | U | Left                   | Thru | Right | U | Left                      | Thru | Right | U | Left                      | Thru | Right | U |       |               |     |
| 6:00 AM                         | 1                      | 0    | 0     | 0 | 0                      | 0    | 0     | 0 | 0                         | 1    | 0     | 0 | 0                         | 0    | 1     | 0 | 0     | 3             |     |
| 6:05 AM                         | 0                      | 0    | 0     | 0 | 0                      | 0    | 0     | 0 | 0                         | 2    | 0     | 0 | 0                         | 0    | 0     | 0 | 0     | 2             |     |
| 6:10 AM                         | 0                      | 0    | 0     | 0 | 0                      | 1    | 0     | 0 | 0                         | 0    | 0     | 0 | 0                         | 0    | 0     | 0 | 0     | 1             |     |
| 6:15 AM                         | 0                      | 0    | 0     | 0 | 0                      | 0    | 0     | 0 | 0                         | 0    | 0     | 0 | 0                         | 0    | 0     | 0 | 0     | 0             |     |
| 6:20 AM                         | 0                      | 0    | 0     | 0 | 0                      | 0    | 0     | 0 | 0                         | 0    | 0     | 0 | 0                         | 0    | 0     | 0 | 0     | 0             |     |
| 6:25 AM                         | 0                      | 0    | 0     | 0 | 0                      | 0    | 0     | 0 | 0                         | 1    | 0     | 0 | 0                         | 0    | 0     | 0 | 0     | 1             |     |
| 6:30 AM                         | 0                      | 0    | 0     | 0 | 0                      | 0    | 0     | 0 | 0                         | 0    | 0     | 0 | 0                         | 0    | 1     | 0 | 0     | 1             |     |
| 6:35 AM                         | 0                      | 0    | 0     | 0 | 0                      | 0    | 0     | 0 | 0                         | 1    | 0     | 0 | 0                         | 0    | 1     | 0 | 0     | 2             |     |
| 6:40 AM                         | 0                      | 0    | 0     | 0 | 0                      | 1    | 0     | 0 | 0                         | 3    | 0     | 0 | 0                         | 0    | 0     | 0 | 0     | 4             |     |
| 6:45 AM                         | 0                      | 0    | 0     | 0 | 0                      | 0    | 0     | 0 | 0                         | 3    | 0     | 0 | 0                         | 0    | 0     | 1 | 0     | 4             |     |
| 6:50 AM                         | 0                      | 0    | 0     | 0 | 0                      | 0    | 0     | 0 | 0                         | 1    | 0     | 0 | 0                         | 0    | 0     | 0 | 0     | 1             |     |
| 6:55 AM                         | 1                      | 0    | 0     | 0 | 1                      | 0    | 0     | 0 | 0                         | 1    | 0     | 0 | 0                         | 0    | 0     | 0 | 0     | 3             | 22  |
| 7:00 AM                         | 0                      | 0    | 0     | 0 | 0                      | 1    | 0     | 0 | 0                         | 3    | 0     | 0 | 0                         | 0    | 1     | 0 | 0     | 5             | 24  |
| 7:05 AM                         | 2                      | 0    | 0     | 0 | 0                      | 0    | 0     | 0 | 0                         | 1    | 0     | 0 | 0                         | 0    | 0     | 0 | 0     | 3             | 25  |
| 7:10 AM                         | 0                      | 0    | 0     | 0 | 0                      | 0    | 0     | 0 | 0                         | 4    | 0     | 0 | 0                         | 0    | 1     | 0 | 0     | 5             | 29  |
| 7:15 AM                         | 0                      | 1    | 0     | 0 | 0                      | 0    | 0     | 0 | 0                         | 0    | 0     | 0 | 0                         | 0    | 2     | 0 | 0     | 3             | 32  |
| 7:20 AM                         | 1                      | 0    | 0     | 0 | 0                      | 1    | 0     | 0 | 0                         | 2    | 0     | 0 | 0                         | 0    | 1     | 0 | 0     | 5             | 37  |
| 7:25 AM                         | 0                      | 0    | 0     | 0 | 0                      | 1    | 0     | 0 | 0                         | 3    | 0     | 0 | 0                         | 0    | 0     | 0 | 0     | 4             | 40  |
| 7:30 AM                         | 0                      | 1    | 0     | 0 | 0                      | 0    | 0     | 0 | 0                         | 0    | 0     | 0 | 0                         | 0    | 1     | 0 | 0     | 2             | 41  |
| 7:35 AM                         | 0                      | 0    | 1     | 0 | 1                      | 0    | 0     | 0 | 0                         | 1    | 0     | 0 | 0                         | 0    | 1     | 0 | 0     | 4             | 43  |
| 7:40 AM                         | 0                      | 3    | 0     | 0 | 0                      | 1    | 1     | 0 | 0                         | 7    | 0     | 0 | 0                         | 1    | 9     | 0 | 0     | 22            | 61  |
| 7:45 AM                         | 1                      | 1    | 1     | 0 | 0                      | 3    | 0     | 0 | 0                         | 1    | 8     | 0 | 0                         | 1    | 11    | 0 | 0     | 27            | 84  |
| 7:50 AM                         | 1                      | 3    | 0     | 0 | 0                      | 0    | 0     | 0 | 0                         | 1    | 20    | 0 | 0                         | 0    | 8     | 1 | 0     | 34            | 117 |
| 7:55 AM                         | 0                      | 2    | 0     | 0 | 0                      | 0    | 0     | 0 | 0                         | 2    | 10    | 1 | 0                         | 1    | 6     | 0 | 0     | 22            | 136 |
| 8:00 AM                         | 0                      | 1    | 2     | 0 | 0                      | 1    | 1     | 0 | 0                         | 0    | 10    | 0 | 0                         | 0    | 4     | 1 | 0     | 20            | 151 |
| 8:05 AM                         | 0                      | 4    | 1     | 0 | 0                      | 1    | 0     | 0 | 0                         | 0    | 20    | 1 | 0                         | 0    | 2     | 0 | 0     | 29            | 177 |
| 8:10 AM                         | 0                      | 1    | 1     | 0 | 3                      | 4    | 1     | 0 | 2                         | 9    | 0     | 0 | 0                         | 0    | 1     | 1 | 0     | 23            | 195 |
| 8:15 AM                         | 0                      | 0    | 1     | 0 | 0                      | 1    | 0     | 0 | 0                         | 2    | 0     | 0 | 0                         | 0    | 1     | 0 | 0     | 5             | 197 |
| 8:20 AM                         | 0                      | 0    | 0     | 0 | 0                      | 1    | 0     | 0 | 0                         | 5    | 0     | 0 | 0                         | 0    | 1     | 0 | 0     | 7             | 199 |
| 8:25 AM                         | 0                      | 1    | 0     | 0 | 0                      | 0    | 0     | 0 | 0                         | 2    | 0     | 0 | 0                         | 0    | 2     | 0 | 0     | 5             | 200 |
| 8:30 AM                         | 0                      | 1    | 0     | 0 | 0                      | 1    | 0     | 0 | 1                         | 4    | 0     | 0 | 0                         | 1    | 2     | 0 | 0     | 10            | 208 |
| 8:35 AM                         | 0                      | 0    | 0     | 0 | 0                      | 0    | 0     | 0 | 0                         | 6    | 0     | 0 | 0                         | 0    | 3     | 0 | 0     | 9             | 213 |
| 8:40 AM                         | 0                      | 0    | 0     | 0 | 0                      | 1    | 0     | 0 | 0                         | 1    | 0     | 0 | 0                         | 0    | 0     | 0 | 0     | 2             | 193 |
| 8:45 AM                         | 0                      | 0    | 0     | 0 | 0                      | 0    | 0     | 0 | 0                         | 2    | 0     | 0 | 0                         | 0    | 1     | 0 | 0     | 3             | 169 |
| 8:50 AM                         | 0                      | 1    | 0     | 0 | 0                      | 0    | 0     | 0 | 0                         | 3    | 0     | 0 | 0                         | 0    | 2     | 0 | 0     | 6             | 141 |
| 8:55 AM                         | 0                      | 0    | 0     | 0 | 0                      | 0    | 0     | 0 | 0                         | 2    | 0     | 0 | 0                         | 0    | 1     | 0 | 0     | 3             | 122 |
| 9:00 AM                         | 0                      | 1    | 0     | 0 | 0                      | 2    | 0     | 0 | 0                         | 1    | 0     | 0 | 0                         | 0    | 1     | 0 | 0     | 5             | 107 |
| 9:05 AM                         | 0                      | 1    | 0     | 0 | 0                      | 0    | 0     | 0 | 0                         | 3    | 0     | 0 | 0                         | 0    | 1     | 0 | 0     | 5             | 83  |

**Attachment B**

| 5-Min Count Period Beginning At | Donnis Rd (Northbound) |      |       |   | Donnis Rd (Southbound) |      |       |   | Donnie Ann Rd (Eastbound) |      |       |   | Donnie Ann Rd (Westbound) |      |       |   | Total | Hourly Totals |
|---------------------------------|------------------------|------|-------|---|------------------------|------|-------|---|---------------------------|------|-------|---|---------------------------|------|-------|---|-------|---------------|
|                                 | Left                   | Thru | Right | U | Left                   | Thru | Right | U | Left                      | Thru | Right | U | Left                      | Thru | Right | U |       |               |
| 9:10 AM                         | 0                      | 0    | 0     | 0 | 1                      | 0    | 0     | 0 | 0                         | 2    | 0     | 0 | 0                         | 0    | 0     | 0 | 3     | 63            |
| 9:15 AM                         | 0                      | 0    | 3     | 0 | 0                      | 0    | 0     | 0 | 0                         | 1    | 0     | 0 | 0                         | 0    | 1     | 0 | 5     | 63            |
| 9:20 AM                         | 0                      | 0    | 0     | 0 | 0                      | 1    | 0     | 0 | 0                         | 1    | 0     | 0 | 0                         | 0    | 1     | 0 | 3     | 59            |
| 9:25 AM                         | 0                      | 0    | 0     | 0 | 0                      | 0    | 0     | 0 | 0                         | 0    | 0     | 0 | 0                         | 1    | 0     | 0 | 1     | 55            |
| 9:30 AM                         | 0                      | 0    | 0     | 0 | 0                      | 2    | 0     | 0 | 0                         | 2    | 1     | 0 | 1                         | 1    | 0     | 0 | 7     | 52            |
| 9:35 AM                         | 0                      | 0    | 1     | 0 | 0                      | 0    | 0     | 0 | 0                         | 3    | 0     | 0 | 0                         | 0    | 0     | 0 | 4     | 47            |
| 9:40 AM                         | 0                      | 1    | 0     | 0 | 0                      | 0    | 0     | 0 | 0                         | 1    | 1     | 0 | 0                         | 1    | 0     | 0 | 4     | 49            |
| 9:45 AM                         | 0                      | 2    | 0     | 0 | 0                      | 0    | 1     | 0 | 0                         | 1    | 2     | 0 | 0                         | 0    | 0     | 0 | 6     | 52            |
| 9:50 AM                         | 0                      | 0    | 0     | 0 | 0                      | 0    | 1     | 0 | 0                         | 1    | 0     | 0 | 0                         | 0    | 1     | 0 | 3     | 49            |
| 9:55 AM                         | 0                      | 0    | 0     | 0 | 0                      | 0    | 0     | 0 | 0                         | 2    | 0     | 0 | 1                         | 0    | 0     | 0 | 3     | 49            |
| 10:00 AM                        | 0                      | 1    | 0     | 0 | 0                      | 0    | 0     | 0 | 0                         | 2    | 0     | 0 | 0                         | 0    | 0     | 0 | 3     | 47            |
| 10:05 AM                        | 0                      | 1    | 0     | 0 | 0                      | 2    | 0     | 0 | 0                         | 1    | 0     | 0 | 0                         | 0    | 0     | 0 | 4     | 46            |
| 10:10 AM                        | 0                      | 0    | 0     | 0 | 0                      | 1    | 0     | 0 | 1                         | 0    | 0     | 0 | 0                         | 2    | 0     | 0 | 4     | 47            |
| 10:15 AM                        | 0                      | 0    | 0     | 0 | 0                      | 1    | 0     | 0 | 0                         | 4    | 0     | 0 | 1                         | 1    | 0     | 0 | 7     | 49            |
| 10:20 AM                        | 0                      | 1    | 0     | 0 | 0                      | 0    | 0     | 0 | 0                         | 0    | 0     | 0 | 0                         | 1    | 0     | 0 | 2     | 48            |
| 10:25 AM                        | 0                      | 0    | 0     | 0 | 0                      | 0    | 0     | 0 | 0                         | 4    | 0     | 0 | 0                         | 3    | 0     | 0 | 7     | 54            |
| 10:30 AM                        | 0                      | 0    | 0     | 0 | 0                      | 1    | 0     | 0 | 0                         | 1    | 0     | 0 | 0                         | 1    | 1     | 0 | 4     | 51            |
| 10:35 AM                        | 0                      | 0    | 0     | 0 | 0                      | 0    | 0     | 0 | 0                         | 2    | 0     | 0 | 0                         | 0    | 0     | 0 | 2     | 49            |
| 10:40 AM                        | 0                      | 2    | 0     | 0 | 0                      | 1    | 0     | 0 | 0                         | 2    | 0     | 0 | 0                         | 2    | 0     | 0 | 7     | 52            |
| 10:45 AM                        | 0                      | 0    | 0     | 0 | 0                      | 1    | 0     | 0 | 0                         | 0    | 0     | 0 | 0                         | 2    | 0     | 0 | 3     | 49            |
| 10:50 AM                        | 0                      | 0    | 0     | 0 | 1                      | 0    | 0     | 0 | 0                         | 3    | 0     | 0 | 0                         | 1    | 0     | 0 | 5     | 51            |
| 10:55 AM                        | 0                      | 0    | 0     | 0 | 0                      | 0    | 0     | 0 | 0                         | 4    | 1     | 0 | 0                         | 2    | 0     | 0 | 7     | 55            |
| 11:00 AM                        | 1                      | 0    | 0     | 0 | 0                      | 0    | 0     | 0 | 0                         | 2    | 1     | 0 | 0                         | 3    | 0     | 0 | 7     | 59            |
| 11:05 AM                        | 0                      | 0    | 0     | 0 | 0                      | 1    | 0     | 0 | 0                         | 0    | 0     | 0 | 0                         | 0    | 0     | 0 | 1     | 56            |
| 11:10 AM                        | 0                      | 1    | 0     | 0 | 0                      | 0    | 0     | 0 | 0                         | 2    | 0     | 0 | 0                         | 1    | 0     | 0 | 4     | 56            |
| 11:15 AM                        | 0                      | 0    | 0     | 0 | 0                      | 0    | 1     | 0 | 0                         | 1    | 0     | 0 | 0                         | 0    | 0     | 0 | 2     | 51            |
| 11:20 AM                        | 0                      | 0    | 0     | 0 | 0                      | 1    | 0     | 0 | 0                         | 1    | 0     | 0 | 0                         | 3    | 0     | 0 | 5     | 54            |
| 11:25 AM                        | 0                      | 0    | 0     | 0 | 0                      | 0    | 0     | 0 | 0                         | 1    | 0     | 0 | 0                         | 1    | 0     | 0 | 2     | 49            |
| 11:30 AM                        | 0                      | 0    | 0     | 0 | 0                      | 0    | 0     | 0 | 0                         | 4    | 0     | 0 | 0                         | 0    | 0     | 0 | 4     | 49            |
| 11:35 AM                        | 0                      | 0    | 0     | 0 | 0                      | 0    | 0     | 0 | 0                         | 2    | 0     | 0 | 0                         | 1    | 0     | 0 | 3     | 50            |
| 11:40 AM                        | 0                      | 0    | 0     | 0 | 0                      | 0    | 0     | 0 | 0                         | 2    | 0     | 0 | 1                         | 3    | 0     | 0 | 6     | 49            |
| 11:45 AM                        | 0                      | 0    | 0     | 0 | 0                      | 0    | 0     | 0 | 0                         | 1    | 0     | 0 | 0                         | 1    | 1     | 0 | 3     | 49            |
| 11:50 AM                        | 0                      | 2    | 0     | 0 | 0                      | 1    | 0     | 0 | 0                         | 0    | 0     | 0 | 1                         | 0    | 0     | 0 | 4     | 48            |
| 11:55 AM                        | 0                      | 0    | 0     | 0 | 0                      | 0    | 0     | 0 | 0                         | 0    | 1     | 0 | 0                         | 0    | 0     | 0 | 1     | 42            |
| 12:00 PM                        | 0                      | 0    | 1     | 0 | 0                      | 1    | 0     | 0 | 0                         | 1    | 1     | 0 | 0                         | 1    | 1     | 0 | 6     | 41            |
| 12:05 PM                        | 0                      | 0    | 0     | 0 | 0                      | 0    | 0     | 0 | 0                         | 1    | 0     | 0 | 0                         | 4    | 0     | 0 | 5     | 45            |
| 12:10 PM                        | 0                      | 1    | 0     | 0 | 0                      | 1    | 1     | 0 | 0                         | 3    | 1     | 0 | 0                         | 1    | 1     | 0 | 9     | 50            |
| 12:15 PM                        | 1                      | 0    | 0     | 0 | 0                      | 0    | 0     | 0 | 0                         | 2    | 0     | 0 | 0                         | 3    | 1     | 0 | 7     | 55            |
| 12:20 PM                        | 0                      | 0    | 0     | 0 | 0                      | 0    | 0     | 0 | 0                         | 5    | 3     | 0 | 0                         | 1    | 0     | 0 | 9     | 59            |
| 12:25 PM                        | 0                      | 0    | 0     | 0 | 0                      | 1    | 0     | 0 | 0                         | 1    | 0     | 0 | 1                         | 0    | 0     | 0 | 3     | 60            |
| 12:30 PM                        | 1                      | 0    | 1     | 0 | 0                      | 1    | 1     | 0 | 0                         | 1    | 0     | 0 | 0                         | 0    | 0     | 0 | 5     | 61            |
| 12:35 PM                        | 0                      | 0    | 0     | 0 | 0                      | 0    | 0     | 0 | 0                         | 0    | 0     | 0 | 0                         | 2    | 0     | 0 | 2     | 60            |
| 12:40 PM                        | 0                      | 0    | 0     | 0 | 0                      | 0    | 0     | 0 | 0                         | 1    | 0     | 0 | 0                         | 2    | 0     | 0 | 3     | 57            |
| 12:45 PM                        | 0                      | 0    | 0     | 0 | 0                      | 1    | 1     | 0 | 1                         | 0    | 0     | 0 | 1                         | 1    | 0     | 0 | 5     | 59            |
| 12:50 PM                        | 1                      | 0    | 0     | 0 | 0                      | 0    | 0     | 0 | 0                         | 1    | 0     | 0 | 0                         | 2    | 0     | 0 | 4     | 59            |
| 12:55 PM                        | 0                      | 1    | 0     | 0 | 0                      | 1    | 0     | 0 | 0                         | 1    | 0     | 0 | 2                         | 2    | 0     | 0 | 7     | 65            |
| 1:00 PM                         | 0                      | 1    | 1     | 0 | 0                      | 0    | 0     | 0 | 0                         | 1    | 0     | 0 | 0                         | 3    | 0     | 0 | 6     | 65            |
| 1:05 PM                         | 0                      | 0    | 1     | 0 | 1                      | 1    | 0     | 0 | 0                         | 1    | 0     | 0 | 0                         | 4    | 0     | 0 | 8     | 68            |
| 1:10 PM                         | 1                      | 0    | 0     | 0 | 0                      | 1    | 0     | 0 | 0                         | 1    | 0     | 0 | 0                         | 1    | 0     | 0 | 4     | 63            |
| 1:15 PM                         | 0                      | 1    | 0     | 0 | 0                      | 1    | 0     | 0 | 0                         | 1    | 0     | 0 | 1                         | 6    | 1     | 0 | 11    | 67            |
| 1:20 PM                         | 1                      | 0    | 0     | 0 | 1                      | 0    | 0     | 0 | 0                         | 1    | 1     | 0 | 1                         | 5    | 1     | 0 | 11    | 69            |
| 1:25 PM                         | 1                      | 0    | 2     | 0 | 0                      | 0    | 0     | 0 | 0                         | 1    | 0     | 0 | 0                         | 8    | 0     | 0 | 12    | 78            |
| 1:30 PM                         | 0                      | 0    | 0     | 0 | 1                      | 0    | 0     | 0 | 0                         | 4    | 1     | 0 | 1                         | 3    | 0     | 0 | 10    | 83            |
| 1:35 PM                         | 0                      | 0    | 0     | 0 | 0                      | 0    | 0     | 0 | 1                         | 17   | 0     | 0 | 0                         | 0    | 0     | 0 | 18    | 99            |
| 1:40 PM                         | 0                      | 1    | 0     | 0 | 0                      | 0    | 0     | 0 | 0                         | 7    | 0     | 0 | 0                         | 1    | 0     | 0 | 9     | 105           |
| 1:45 PM                         | 0                      | 0    | 0     | 0 | 0                      | 1    | 1     | 0 | 0                         | 3    | 0     | 0 | 0                         | 0    | 0     | 0 | 5     | 105           |
| 1:50 PM                         | 1                      | 1    | 0     | 0 | 0                      | 1    | 0     | 0 | 0                         | 2    | 0     | 0 | 0                         | 1    | 0     | 0 | 6     | 107           |
| 1:55 PM                         | 0                      | 0    | 0     | 0 | 0                      | 0    | 0     | 0 | 0                         | 3    | 0     | 0 | 0                         | 1    | 0     | 0 | 4     | 104           |
| 2:00 PM                         | 0                      | 0    | 0     | 0 | 0                      | 0    | 0     | 0 | 0                         | 1    | 1     | 0 | 1                         | 0    | 0     | 0 | 3     | 101           |
| 2:05 PM                         | 0                      | 0    | 0     | 0 | 0                      | 1    | 0     | 0 | 0                         | 0    | 0     | 0 | 0                         | 3    | 0     | 0 | 4     | 97            |
| 2:10 PM                         | 0                      | 0    | 0     | 0 | 0                      | 2    | 0     | 0 | 0                         | 2    | 0     | 0 | 0                         | 2    | 0     | 0 | 6     | 99            |
| 2:15 PM                         | 0                      | 0    | 0     | 0 | 0                      | 0    | 0     | 0 | 0                         | 3    | 1     | 0 | 0                         | 4    | 0     | 0 | 8     | 96            |
| 2:20 PM                         | 0                      | 2    | 0     | 0 | 0                      | 1    | 0     | 0 | 0                         | 3    | 0     | 0 | 2                         | 0    | 1     | 0 | 9     | 94            |
| 2:25 PM                         | 0                      | 0    | 1     | 0 | 1                      | 2    | 2     | 0 | 0                         | 3    | 1     | 0 | 3                         | 2    | 0     | 0 | 15    | 97            |
| 2:30 PM                         | 1                      | 0    | 0     | 0 | 0                      | 1    | 0     | 0 | 0                         | 1    | 0     | 0 | 0                         | 4    | 0     | 0 | 7     | 94            |
| 2:35 PM                         | 0                      | 0    | 0     | 0 | 0                      | 0    | 0     | 0 | 0                         | 4    | 1     | 0 | 1                         | 3    | 0     | 0 | 9     | 85            |
| 2:40 PM                         | 0                      | 0    | 0     | 0 | 0                      | 6    | 1     | 0 | 0                         | 4    | 2     | 0 | 1                         | 2    | 0     | 0 | 16    | 92            |
| 2:45 PM                         | 0                      | 1    | 0     | 0 | 0                      | 0    | 0     | 0 | 0                         | 2    | 0     | 0 | 0                         | 0    | 0     | 0 | 3     | 90            |
| 2:50 PM                         | 0                      | 1    | 0     | 0 | 0                      | 1    | 1     | 0 | 0                         | 0    | 0     | 0 | 0                         | 0    | 0     | 0 | 3     | 87            |
| 2:55 PM                         | 0                      | 1    | 0     | 0 | 0                      | 2    | 0     | 0 | 0                         | 4    | 0     | 0 | 1                         | 5    | 0     | 0 | 13    | 96            |
| 3:00 PM                         | 0                      | 0    | 0     | 0 | 0                      | 0    | 0     | 0 | 0                         | 5    | 0     | 0 | 1                         | 1    | 0     | 0 | 7     | 100           |
| 3:05 PM                         | 0                      | 0    | 0     | 0 | 0                      | 1    | 0     | 0 | 0                         | 2    | 0     | 0 | 0                         | 1    | 0     | 0 | 4     | 100           |
| 3:10 PM                         | 0                      | 0    | 0     | 0 | 0                      | 0    | 0     | 0 | 0                         | 2    | 0     | 0 | 2                         | 2    | 0     | 0 | 6     | 100           |
| 3:15 PM                         | 0                      | 3    | 1     | 0 | 0                      | 0    | 0     | 0 | 0                         | 1    | 0     | 0 | 0                         | 1    | 0     | 0 | 6     | 98            |
| 3:20 PM                         | 0                      | 0    | 0     | 0 | 0                      | 0    | 0     | 0 | 0                         | 0    | 0     | 0 | 0                         | 0    | 0     | 0 | 0     | 89            |
| 3:25 PM                         | 0                      | 0    | 1     | 0 | 0                      | 0    | 1     | 0 | 0                         | 0    | 1     | 0 | 2                         | 2    | 0     | 0 | 7     | 81            |
| 3:30 PM                         | 0                      | 2    | 0     | 0 | 0                      | 1    | 0     | 0 | 0                         | 1    | 0     | 0 | 0                         | 1    | 0     | 0 | 5     | 79            |
| 3:35 PM                         | 0                      | 0    | 0     | 0 | 0                      | 0    | 1     | 0 | 1                         | 0    | 0     | 0 | 1                         | 3    | 1     | 0 | 7     | 77            |
| 3:40 PM                         | 0                      | 2    | 1     | 0 | 0                      | 3    | 0     | 0 | 0                         | 0    | 0     | 0 | 4                         | 3    | 0     | 0 | 13    | 74            |
| 3:45 PM                         | 1                      | 1    | 0     | 0 | 0                      | 2    | 2     | 0 | 0                         | 6    | 0     | 0 | 0                         | 3    | 0     | 0 | 15    | 86            |
| 3:50 PM                         | 0                      | 2    | 1     | 0 | 0                      | 0    | 0     | 0 | 0                         | 3    | 0     | 0 | 0                         | 1    | 0     | 0 | 7     | 90            |
| 3:55 PM                         | 0                      | 1    | 0     | 0 | 0                      | 0    | 0     | 0 | 0                         | 4    | 0     | 0 | 1                         | 2    | 0     | 0 | 8     | 85            |
| 4:00 PM                         | 1                      | 1    | 0     | 0 | 0                      | 1    | 0     | 0 | 0                         | 2    | 0     | 0 | 0                         | 1    | 0     | 0 | 6     | 84            |
| 4:05 PM                         | 1                      | 1    | 1     | 0 | 0                      | 0    | 0     | 0 | 0                         | 0    | 0     | 0 | 0                         | 2    | 0     | 0 | 5     | 85            |
| 4:10 PM                         | 0                      | 1    | 0     | 0 | 0                      | 2    | 0     | 0 | 0                         | 3    | 0     | 0 | 1                         | 2    | 0     | 0 | 9     | 88            |
| 4:15 PM                         | 0                      | 0    | 0     | 0 | 0                      | 1    | 0     | 0 | 0                         | 1    | 0     | 0 | 1                         | 2    | 0     | 0 | 5     | 87            |
| 4:20 PM                         | 0                      | 0    | 1     | 0 | 0                      | 2    | 0     | 0 | 0                         | 3    | 1     | 0 | 1                         | 2    | 0     | 0 | 10    | 97            |
| 4:25 PM                         | 0                      | 4    | 0     | 0 | 0                      | 4    | 0     | 0 | 0                         | 0    | 0     | 0 | 2                         | 3    | 0     | 0 | 13    | 103           |
| 4:30 PM                         | 1                      | 1    | 0     | 0 | 0                      | 1    | 1     | 0 | 0                         | 0    | 5     | 1 | 0                         | 4    | 0     | 0 | 17    | 115           |

## Attachment B

| 5-Min Count Period Beginning At | Donnis Rd (Northbound) |      |       |   | Donnis Rd (Southbound) |      |       |   | Donnie Ann Rd (Eastbound) |      |       |   | Donnie Ann Rd (Westbound) |      |       |   | Total | Hourly Totals |
|---------------------------------|------------------------|------|-------|---|------------------------|------|-------|---|---------------------------|------|-------|---|---------------------------|------|-------|---|-------|---------------|
|                                 | Left                   | Thru | Right | U | Left                   | Thru | Right | U | Left                      | Thru | Right | U | Left                      | Thru | Right | U |       |               |
| 4:35 PM                         | 0                      | 1    | 0     | 0 | 0                      | 3    | 0     | 0 | 1                         | 1    | 0     | 0 | 1                         | 1    | 0     | 0 | 8     | 116           |
| 4:40 PM                         | 0                      | 3    | 0     | 0 | 0                      | 0    | 0     | 0 | 1                         | 1    | 0     | 0 | 0                         | 2    | 1     | 0 | 8     | 111           |
| 4:45 PM                         | 0                      | 0    | 0     | 0 | 0                      | 4    | 0     | 0 | 1                         | 2    | 0     | 0 | 2                         | 0    | 0     | 0 | 9     | 105           |
| 4:50 PM                         | 0                      | 1    | 1     | 0 | 0                      | 5    | 2     | 0 | 0                         | 2    | 1     | 0 | 3                         | 6    | 0     | 0 | 21    | 119           |
| 4:55 PM                         | 0                      | 0    | 0     | 0 | 0                      | 1    | 0     | 0 | 0                         | 2    | 1     | 0 | 3                         | 3    | 0     | 0 | 10    | 121           |
| 5:00 PM                         | 0                      | 3    | 0     | 0 | 0                      | 2    | 0     | 0 | 0                         | 2    | 0     | 0 | 3                         | 0    | 0     | 0 | 10    | 125           |
| 5:05 PM                         | 1                      | 0    | 0     | 0 | 1                      | 1    | 0     | 0 | 1                         | 3    | 0     | 0 | 1                         | 0    | 0     | 0 | 8     | 128           |
| 5:10 PM                         | 0                      | 0    | 0     | 0 | 1                      | 3    | 1     | 0 | 0                         | 0    | 0     | 0 | 0                         | 1    | 0     | 0 | 6     | 125           |
| 5:15 PM                         | 0                      | 0    | 0     | 0 | 1                      | 3    | 0     | 0 | 0                         | 1    | 0     | 0 | 0                         | 0    | 0     | 0 | 5     | 125           |
| 5:20 PM                         | 0                      | 1    | 2     | 0 | 0                      | 1    | 0     | 0 | 0                         | 2    | 0     | 0 | 0                         | 0    | 0     | 0 | 6     | 121           |
| 5:25 PM                         | 0                      | 1    | 0     | 0 | 0                      | 0    | 0     | 0 | 1                         | 3    | 0     | 0 | 1                         | 2    | 0     | 0 | 8     | 116           |
| 5:30 PM                         | 0                      | 0    | 0     | 0 | 0                      | 1    | 0     | 0 | 0                         | 1    | 0     | 0 | 1                         | 8    | 0     | 0 | 11    | 110           |
| 5:35 PM                         | 0                      | 1    | 0     | 0 | 0                      | 0    | 0     | 0 | 0                         | 3    | 1     | 0 | 1                         | 3    | 0     | 0 | 9     | 111           |
| 5:40 PM                         | 0                      | 0    | 1     | 0 | 0                      | 0    | 0     | 0 | 0                         | 4    | 0     | 0 | 1                         | 2    | 0     | 0 | 8     | 111           |
| 5:45 PM                         | 0                      | 0    | 0     | 0 | 0                      | 0    | 0     | 0 | 0                         | 1    | 0     | 0 | 0                         | 2    | 0     | 0 | 3     | 105           |
| 5:50 PM                         | 0                      | 1    | 0     | 0 | 0                      | 0    | 1     | 0 | 0                         | 2    | 0     | 0 | 0                         | 0    | 0     | 0 | 4     | 88            |
| 5:55 PM                         | 0                      | 1    | 1     | 0 | 0                      | 0    | 0     | 0 | 0                         | 2    | 0     | 0 | 0                         | 3    | 0     | 0 | 7     | 85            |
| 6:00 PM                         | 1                      | 1    | 0     | 0 | 0                      | 0    | 0     | 0 | 0                         | 0    | 0     | 0 | 1                         | 1    | 0     | 0 | 4     | 79            |
| 6:05 PM                         | 1                      | 1    | 0     | 0 | 0                      | 0    | 0     | 0 | 0                         | 0    | 0     | 0 | 0                         | 0    | 0     | 0 | 2     | 73            |
| 6:10 PM                         | 1                      | 2    | 0     | 0 | 0                      | 0    | 0     | 0 | 0                         | 2    | 0     | 0 | 0                         | 3    | 0     | 0 | 8     | 75            |
| 6:15 PM                         | 1                      | 0    | 0     | 0 | 0                      | 0    | 0     | 0 | 0                         | 2    | 0     | 0 | 0                         | 0    | 0     | 0 | 3     | 73            |
| 6:20 PM                         | 0                      | 1    | 1     | 0 | 0                      | 2    | 0     | 0 | 0                         | 1    | 0     | 0 | 0                         | 2    | 0     | 0 | 7     | 74            |
| 6:25 PM                         | 0                      | 0    | 0     | 0 | 0                      | 1    | 0     | 0 | 0                         | 3    | 0     | 0 | 1                         | 0    | 0     | 0 | 5     | 71            |
| 6:30 PM                         | 0                      | 0    | 1     | 0 | 0                      | 0    | 1     | 0 | 0                         | 3    | 0     | 0 | 0                         | 3    | 0     | 0 | 8     | 68            |
| 6:35 PM                         | 0                      | 1    | 0     | 0 | 0                      | 0    | 0     | 0 | 0                         | 1    | 0     | 0 | 1                         | 2    | 0     | 0 | 5     | 64            |
| 6:40 PM                         | 0                      | 3    | 0     | 0 | 0                      | 0    | 0     | 0 | 0                         | 3    | 0     | 0 | 0                         | 1    | 0     | 0 | 7     | 63            |
| 6:45 PM                         | 1                      | 0    | 0     | 0 | 0                      | 0    | 0     | 0 | 1                         | 1    | 0     | 0 | 0                         | 2    | 0     | 0 | 5     | 65            |
| 6:50 PM                         | 0                      | 1    | 0     | 0 | 0                      | 0    | 0     | 0 | 0                         | 1    | 1     | 0 | 0                         | 2    | 0     | 0 | 5     | 66            |
| 6:55 PM                         | 0                      | 1    | 0     | 0 | 0                      | 1    | 0     | 0 | 0                         | 1    | 0     | 0 | 1                         | 5    | 0     | 0 | 9     | 68            |
| 7:00 PM                         | 0                      | 0    | 0     | 0 | 0                      | 0    | 0     | 0 | 0                         | 2    | 0     | 0 | 0                         | 1    | 0     | 0 | 3     | 67            |
| 7:05 PM                         | 0                      | 0    | 0     | 0 | 0                      | 0    | 0     | 0 | 0                         | 1    | 0     | 0 | 0                         | 0    | 0     | 0 | 1     | 66            |
| 7:10 PM                         | 0                      | 0    | 0     | 0 | 0                      | 0    | 0     | 0 | 0                         | 1    | 0     | 0 | 0                         | 1    | 0     | 0 | 2     | 60            |
| 7:15 PM                         | 0                      | 0    | 0     | 0 | 0                      | 0    | 0     | 0 | 0                         | 1    | 0     | 0 | 0                         | 2    | 0     | 0 | 3     | 60            |
| 7:20 PM                         | 0                      | 0    | 0     | 0 | 0                      | 0    | 0     | 0 | 0                         | 2    | 0     | 0 | 0                         | 0    | 0     | 0 | 2     | 55            |
| 7:25 PM                         | 0                      | 0    | 0     | 0 | 0                      | 0    | 0     | 0 | 0                         | 0    | 0     | 0 | 1                         | 0    | 0     | 0 | 1     | 51            |
| 7:30 PM                         | 0                      | 0    | 0     | 0 | 0                      | 0    | 0     | 0 | 1                         | 1    | 0     | 0 | 0                         | 1    | 0     | 0 | 3     | 46            |
| 7:35 PM                         | 1                      | 0    | 0     | 0 | 0                      | 0    | 0     | 0 | 0                         | 0    | 0     | 0 | 0                         | 1    | 0     | 0 | 2     | 43            |
| 7:40 PM                         | 0                      | 0    | 0     | 0 | 0                      | 0    | 0     | 0 | 0                         | 0    | 0     | 0 | 0                         | 3    | 0     | 0 | 3     | 39            |
| 7:45 PM                         | 0                      | 0    | 0     | 0 | 0                      | 0    | 0     | 0 | 0                         | 1    | 0     | 0 | 0                         | 2    | 0     | 0 | 3     | 37            |
| 7:50 PM                         | 0                      | 0    | 0     | 0 | 0                      | 0    | 0     | 0 | 0                         | 1    | 0     | 0 | 0                         | 0    | 0     | 0 | 1     | 33            |
| 7:55 PM                         | 0                      | 0    | 0     | 0 | 0                      | 0    | 0     | 0 | 0                         | 1    | 0     | 0 | 0                         | 2    | 0     | 0 | 3     | 27            |
| 8:00 PM                         | 0                      | 0    | 0     | 0 | 0                      | 0    | 0     | 0 | 0                         | 0    | 0     | 0 | 0                         | 3    | 0     | 0 | 3     | 27            |
| 8:05 PM                         | 1                      | 1    | 1     | 0 | 0                      | 0    | 0     | 0 | 0                         | 1    | 0     | 0 | 0                         | 0    | 0     | 0 | 4     | 30            |
| 8:10 PM                         | 0                      | 0    | 0     | 0 | 0                      | 0    | 0     | 0 | 0                         | 1    | 1     | 0 | 0                         | 2    | 0     | 0 | 4     | 32            |
| 8:15 PM                         | 0                      | 1    | 1     | 0 | 0                      | 2    | 0     | 0 | 0                         | 1    | 0     | 0 | 0                         | 2    | 0     | 0 | 7     | 36            |
| 8:20 PM                         | 1                      | 0    | 0     | 0 | 0                      | 0    | 0     | 0 | 0                         | 1    | 0     | 0 | 0                         | 1    | 0     | 0 | 3     | 37            |
| 8:25 PM                         | 0                      | 0    | 0     | 0 | 0                      | 0    | 0     | 0 | 0                         | 0    | 0     | 0 | 1                         | 0    | 0     | 0 | 1     | 37            |
| 8:30 PM                         | 1                      | 0    | 0     | 0 | 0                      | 0    | 0     | 0 | 0                         | 0    | 0     | 0 | 0                         | 1    | 0     | 0 | 2     | 36            |
| 8:35 PM                         | 0                      | 1    | 1     | 0 | 0                      | 0    | 0     | 0 | 0                         | 0    | 0     | 0 | 0                         | 2    | 0     | 0 | 4     | 38            |
| 8:40 PM                         | 1                      | 0    | 0     | 0 | 0                      | 0    | 0     | 0 | 0                         | 0    | 0     | 0 | 0                         | 1    | 0     | 0 | 2     | 37            |
| 8:45 PM                         | 1                      | 1    | 0     | 0 | 0                      | 0    | 1     | 0 | 0                         | 0    | 0     | 0 | 0                         | 1    | 0     | 0 | 4     | 38            |
| 8:50 PM                         | 1                      | 0    | 1     | 0 | 0                      | 0    | 0     | 0 | 0                         | 1    | 0     | 0 | 0                         | 1    | 0     | 0 | 4     | 41            |
| 8:55 PM                         | 0                      | 1    | 0     | 0 | 0                      | 0    | 0     | 0 | 0                         | 0    | 0     | 0 | 0                         | 3    | 0     | 0 | 4     | 42            |
| 9:00 PM                         | 1                      | 1    | 0     | 0 | 0                      | 0    | 0     | 0 | 0                         | 0    | 0     | 0 | 0                         | 0    | 0     | 0 | 2     | 41            |
| 9:05 PM                         | 0                      | 2    | 0     | 0 | 0                      | 0    | 0     | 0 | 0                         | 0    | 0     | 0 | 0                         | 1    | 0     | 0 | 3     | 40            |
| 9:10 PM                         | 0                      | 0    | 0     | 0 | 1                      | 0    | 0     | 0 | 0                         | 0    | 0     | 0 | 0                         | 1    | 0     | 0 | 2     | 38            |
| 9:15 PM                         | 0                      | 0    | 1     | 0 | 0                      | 1    | 0     | 0 | 0                         | 0    | 0     | 0 | 0                         | 0    | 0     | 0 | 2     | 33            |
| 9:20 PM                         | 0                      | 0    | 0     | 0 | 0                      | 0    | 0     | 0 | 0                         | 0    | 0     | 0 | 0                         | 0    | 0     | 0 | 0     | 30            |
| 9:25 PM                         | 0                      | 1    | 0     | 0 | 0                      | 0    | 0     | 0 | 0                         | 0    | 0     | 0 | 1                         | 0    | 0     | 0 | 2     | 31            |
| 9:30 PM                         | 0                      | 0    | 0     | 0 | 0                      | 0    | 0     | 0 | 0                         | 0    | 0     | 0 | 1                         | 2    | 0     | 0 | 3     | 32            |
| 9:35 PM                         | 0                      | 2    | 0     | 0 | 0                      | 0    | 1     | 0 | 0                         | 0    | 0     | 0 | 0                         | 1    | 1     | 0 | 5     | 33            |
| 9:40 PM                         | 0                      | 0    | 0     | 0 | 0                      | 0    | 0     | 0 | 0                         | 0    | 0     | 0 | 0                         | 0    | 0     | 0 | 0     | 31            |
| 9:45 PM                         | 0                      | 0    | 0     | 0 | 0                      | 0    | 0     | 0 | 0                         | 1    | 1     | 0 | 1                         | 0    | 0     | 0 | 3     | 30            |
| 9:50 PM                         | 0                      | 0    | 0     | 0 | 0                      | 1    | 1     | 0 | 0                         | 0    | 0     | 0 | 0                         | 0    | 0     | 0 | 2     | 28            |
| 9:55 PM                         | 0                      | 0    | 0     | 0 | 0                      | 0    | 0     | 0 | 0                         | 1    | 0     | 0 | 0                         | 0    | 0     | 0 | 1     | 25            |
| Peak 15-Min Flowrates           | Northbound             |      |       |   | Southbound             |      |       |   | Eastbound                 |      |       |   | Westbound                 |      |       |   | Total |               |
|                                 | Left                   | Thru | Right | U | Left                   | Thru | Right | U | Left                      | Thru | Right | U | Left                      | Thru | Right | U |       |               |
| All Vehicles                    | 8                      | 28   | 4     | 0 | 0                      | 16   | 4     | 0 | 8                         | 140  | 0     | 0 | 8                         | 112  | 4     | 0 | 332   |               |
| Heavy Trucks                    | 0                      | 0    | 0     | 0 | 0                      | 4    | 0     | 0 | 0                         | 0    | 0     | 0 | 0                         | 0    | 0     | 0 | 4     |               |
| Buses                           |                        |      |       |   |                        |      |       |   |                           |      |       |   |                           |      |       |   |       |               |
| Pedestrians                     |                        | 0    |       |   |                        | 0    |       |   |                           | 12   |       |   |                           | 0    |       |   | 12    |               |
| Bicycles                        | 0                      | 0    | 4     |   | 0                      | 0    | 0     |   | 0                         | 0    | 0     |   | 0                         | 0    | 0     |   | 4     |               |
| Scoters                         |                        |      |       |   |                        |      |       |   |                           |      |       |   |                           |      |       |   |       |               |
| <i>Comments:</i>                |                        |      |       |   |                        |      |       |   |                           |      |       |   |                           |      |       |   |       |               |

LOCATION: Kensington Rd -- Piedmont Ave  
 CITY/STATE: Rossmore, CA

QC JOB #: 16966422  
 DATE: Wed, Apr 9 2025

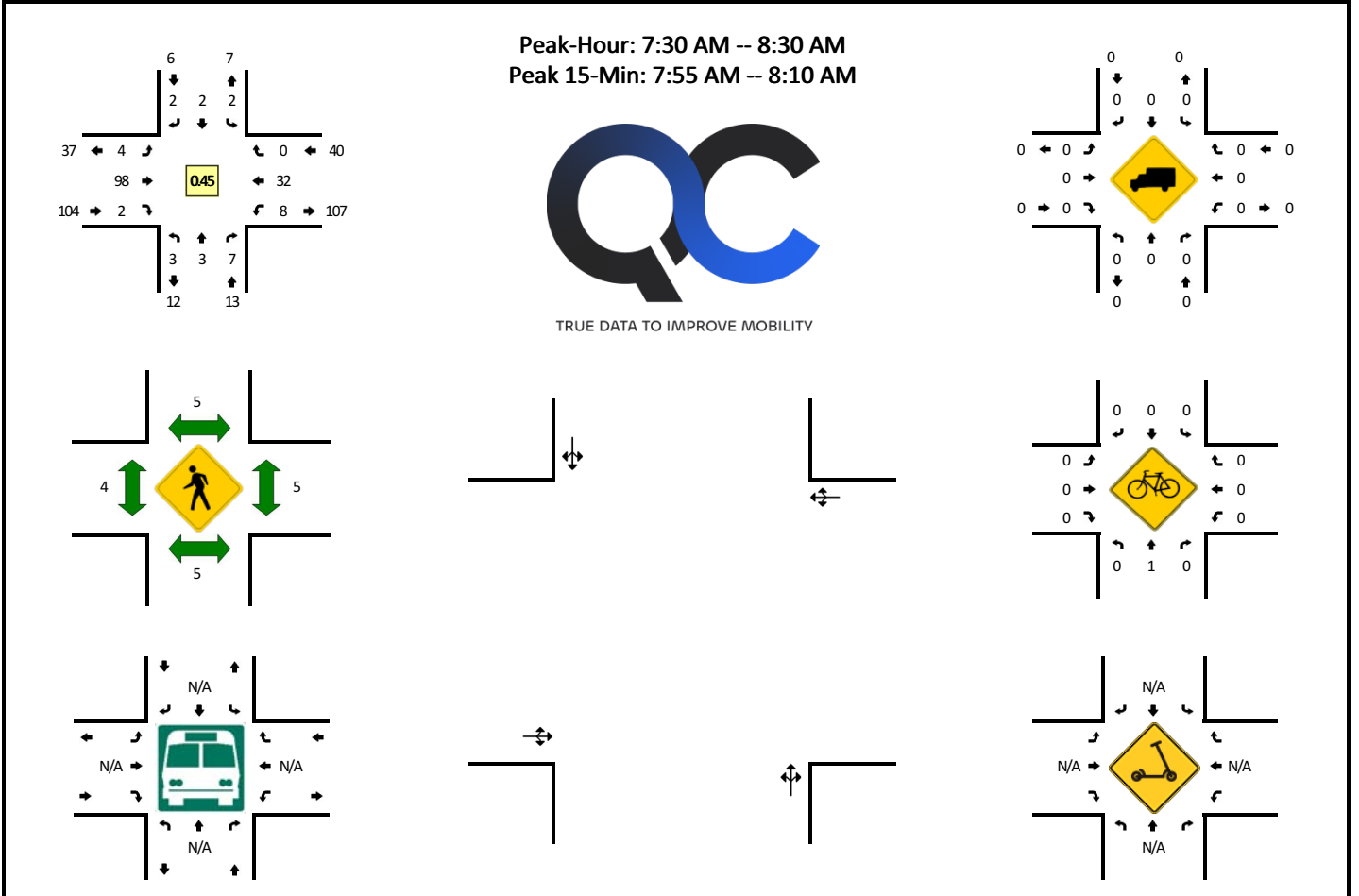

| 5-Min Count Period Beginning At | Kensington Rd (Northbound) |      |       |   | Kensington Rd (Southbound) |      |       |   | Piedmont Ave (Eastbound) |      |       |   | Piedmont Ave (Westbound) |      |       |   | Total | Hourly Totals |
|---------------------------------|----------------------------|------|-------|---|----------------------------|------|-------|---|--------------------------|------|-------|---|--------------------------|------|-------|---|-------|---------------|
|                                 | Left                       | Thru | Right | U | Left                       | Thru | Right | U | Left                     | Thru | Right | U | Left                     | Thru | Right | U |       |               |
| 6:00 AM                         | 0                          | 0    | 0     | 0 | 0                          | 0    | 0     | 0 | 0                        | 0    | 1     | 0 | 0                        | 0    | 0     | 0 | 1     |               |
| 6:05 AM                         | 0                          | 1    | 0     | 0 | 0                          | 0    | 0     | 0 | 0                        | 0    | 0     | 0 | 0                        | 0    | 1     | 0 | 2     |               |
| 6:10 AM                         | 0                          | 0    | 0     | 0 | 0                          | 0    | 0     | 0 | 0                        | 0    | 0     | 0 | 0                        | 0    | 0     | 0 | 0     |               |
| 6:15 AM                         | 0                          | 0    | 0     | 0 | 0                          | 0    | 0     | 0 | 0                        | 0    | 1     | 0 | 0                        | 0    | 0     | 0 | 1     |               |
| 6:20 AM                         | 0                          | 0    | 0     | 0 | 0                          | 0    | 0     | 0 | 0                        | 0    | 0     | 1 | 0                        | 0    | 1     | 0 | 2     |               |
| 6:25 AM                         | 0                          | 0    | 1     | 0 | 0                          | 0    | 0     | 0 | 0                        | 0    | 0     | 0 | 0                        | 0    | 0     | 0 | 1     |               |
| 6:30 AM                         | 0                          | 0    | 1     | 0 | 0                          | 0    | 0     | 0 | 0                        | 0    | 1     | 0 | 0                        | 0    | 0     | 0 | 2     |               |
| 6:35 AM                         | 0                          | 1    | 0     | 0 | 0                          | 0    | 0     | 0 | 0                        | 0    | 0     | 0 | 0                        | 0    | 0     | 0 | 1     |               |
| 6:40 AM                         | 0                          | 0    | 1     | 0 | 1                          | 0    | 0     | 0 | 0                        | 0    | 0     | 0 | 0                        | 0    | 0     | 0 | 2     |               |
| 6:45 AM                         | 0                          | 0    | 0     | 0 | 0                          | 0    | 0     | 0 | 0                        | 0    | 0     | 0 | 0                        | 0    | 0     | 0 | 0     |               |
| 6:50 AM                         | 0                          | 0    | 2     | 0 | 0                          | 0    | 0     | 0 | 0                        | 0    | 0     | 0 | 0                        | 0    | 1     | 0 | 3     |               |
| 6:55 AM                         | 0                          | 0    | 0     | 0 | 0                          | 0    | 0     | 0 | 0                        | 0    | 0     | 0 | 0                        | 0    | 0     | 0 | 0     | 15            |
| 7:00 AM                         | 0                          | 0    | 0     | 0 | 0                          | 0    | 0     | 0 | 0                        | 0    | 1     | 0 | 0                        | 0    | 0     | 0 | 1     | 15            |
| 7:05 AM                         | 1                          | 0    | 1     | 0 | 0                          | 0    | 0     | 0 | 0                        | 0    | 3     | 0 | 0                        | 0    | 0     | 0 | 5     | 18            |
| 7:10 AM                         | 0                          | 1    | 0     | 0 | 0                          | 1    | 0     | 0 | 0                        | 0    | 0     | 0 | 0                        | 1    | 1     | 0 | 4     | 22            |
| 7:15 AM                         | 1                          | 0    | 0     | 0 | 0                          | 1    | 0     | 0 | 0                        | 0    | 0     | 0 | 0                        | 0    | 0     | 0 | 2     | 23            |
| 7:20 AM                         | 0                          | 0    | 0     | 0 | 0                          | 0    | 0     | 0 | 0                        | 1    | 0     | 1 | 0                        | 0    | 0     | 0 | 2     | 23            |
| 7:25 AM                         | 0                          | 1    | 0     | 0 | 0                          | 1    | 0     | 0 | 0                        | 0    | 0     | 0 | 0                        | 0    | 0     | 0 | 2     | 24            |
| 7:30 AM                         | 0                          | 0    | 1     | 0 | 0                          | 0    | 0     | 0 | 0                        | 0    | 4     | 0 | 0                        | 0    | 0     | 0 | 5     | 27            |
| 7:35 AM                         | 0                          | 0    | 0     | 0 | 0                          | 0    | 0     | 0 | 0                        | 0    | 4     | 0 | 0                        | 0    | 1     | 0 | 5     | 31            |
| 7:40 AM                         | 0                          | 0    | 0     | 0 | 0                          | 1    | 0     | 0 | 0                        | 0    | 6     | 0 | 0                        | 0    | 0     | 0 | 7     | 36            |
| 7:45 AM                         | 0                          | 1    | 1     | 0 | 0                          | 1    | 0     | 0 | 0                        | 0    | 12    | 0 | 0                        | 0    | 0     | 0 | 15    | 51            |
| 7:50 AM                         | 0                          | 1    | 0     | 0 | 1                          | 0    | 1     | 0 | 0                        | 0    | 9     | 0 | 0                        | 0    | 3     | 0 | 15    | 63            |
| 7:55 AM                         | 0                          | 1    | 0     | 0 | 0                          | 0    | 1     | 0 | 0                        | 0    | 18    | 0 | 0                        | 4    | 6     | 0 | 30    | 93            |
| 8:00 AM                         | 1                          | 0    | 1     | 0 | 1                          | 0    | 0     | 0 | 0                        | 1    | 23    | 0 | 0                        | 1    | 5     | 0 | 33    | 125           |
| 8:05 AM                         | 1                          | 0    | 2     | 0 | 0                          | 0    | 0     | 0 | 0                        | 1    | 15    | 0 | 0                        | 1    | 8     | 0 | 28    | 148           |
| 8:10 AM                         | 0                          | 0    | 0     | 0 | 0                          | 0    | 0     | 0 | 0                        | 1    | 5     | 1 | 0                        | 1    | 5     | 0 | 13    | 157           |
| 8:15 AM                         | 1                          | 0    | 0     | 0 | 0                          | 0    | 0     | 0 | 0                        | 0    | 1     | 0 | 0                        | 0    | 2     | 0 | 4     | 159           |
| 8:20 AM                         | 0                          | 0    | 0     | 0 | 0                          | 0    | 0     | 0 | 0                        | 0    | 0     | 0 | 0                        | 0    | 0     | 0 | 0     | 157           |
| 8:25 AM                         | 0                          | 0    | 2     | 0 | 0                          | 0    | 0     | 0 | 0                        | 1    | 1     | 1 | 0                        | 1    | 2     | 0 | 8     | 163           |
| 8:30 AM                         | 0                          | 0    | 0     | 0 | 0                          | 0    | 0     | 0 | 0                        | 0    | 0     | 0 | 0                        | 0    | 1     | 0 | 1     | 159           |
| 8:35 AM                         | 0                          | 0    | 0     | 0 | 0                          | 1    | 0     | 0 | 0                        | 0    | 1     | 1 | 0                        | 0    | 0     | 0 | 3     | 157           |
| 8:40 AM                         | 0                          | 0    | 0     | 0 | 0                          | 0    | 0     | 0 | 0                        | 0    | 0     | 0 | 0                        | 0    | 0     | 0 | 0     | 150           |
| 8:45 AM                         | 0                          | 0    | 0     | 0 | 0                          | 0    | 0     | 0 | 0                        | 0    | 0     | 1 | 0                        | 0    | 0     | 1 | 2     | 137           |
| 8:50 AM                         | 0                          | 0    | 0     | 0 | 0                          | 0    | 1     | 0 | 0                        | 0    | 0     | 0 | 0                        | 0    | 0     | 0 | 1     | 123           |
| 8:55 AM                         | 0                          | 1    | 1     | 0 | 1                          | 0    | 0     | 0 | 0                        | 0    | 0     | 0 | 0                        | 1    | 0     | 0 | 4     | 97            |
| 9:00 AM                         | 1                          | 0    | 0     | 0 | 0                          | 0    | 0     | 0 | 0                        | 0    | 0     | 0 | 0                        | 0    | 0     | 0 | 1     | 65            |
| 9:05 AM                         | 1                          | 1    | 0     | 0 | 0                          | 0    | 0     | 0 | 0                        | 0    | 0     | 0 | 0                        | 0    | 0     | 0 | 2     | 39            |

Attachment B

| 5-Min Count Period Beginning At | Kensington Rd (Northbound) |      |       |   | Kensington Rd (Southbound) |      |       |   | Piedmont Ave (Eastbound) |      |       |   | Piedmont Ave (Westbound) |      |       |   | Total | Hourly Totals |
|---------------------------------|----------------------------|------|-------|---|----------------------------|------|-------|---|--------------------------|------|-------|---|--------------------------|------|-------|---|-------|---------------|
|                                 | Left                       | Thru | Right | U | Left                       | Thru | Right | U | Left                     | Thru | Right | U | Left                     | Thru | Right | U |       |               |
| 9:10 AM                         | 0                          | 0    | 0     | 0 | 0                          | 0    | 0     | 0 | 0                        | 2    | 0     | 0 | 0                        | 0    | 0     | 0 | 2     | 28            |
| 9:15 AM                         | 0                          | 0    | 0     | 0 | 0                          | 0    | 0     | 0 | 0                        | 0    | 0     | 0 | 0                        | 0    | 0     | 0 | 0     | 24            |
| 9:20 AM                         | 0                          | 0    | 0     | 0 | 0                          | 0    | 0     | 0 | 0                        | 0    | 0     | 0 | 1                        | 0    | 0     | 0 | 1     | 25            |
| 9:25 AM                         | 0                          | 2    | 0     | 0 | 0                          | 0    | 0     | 0 | 0                        | 1    | 0     | 0 | 0                        | 0    | 0     | 0 | 3     | 20            |
| 9:30 AM                         | 0                          | 0    | 1     | 0 | 0                          | 0    | 0     | 0 | 0                        | 0    | 0     | 0 | 0                        | 0    | 0     | 0 | 1     | 20            |
| 9:35 AM                         | 0                          | 0    | 0     | 0 | 0                          | 0    | 0     | 0 | 0                        | 0    | 0     | 0 | 0                        | 0    | 0     | 0 | 0     | 17            |
| 9:40 AM                         | 0                          | 0    | 0     | 0 | 0                          | 0    | 0     | 0 | 0                        | 0    | 0     | 0 | 0                        | 0    | 0     | 0 | 0     | 17            |
| 9:45 AM                         | 0                          | 1    | 0     | 0 | 0                          | 0    | 0     | 0 | 0                        | 1    | 1     | 0 | 0                        | 0    | 1     | 0 | 4     | 19            |
| 9:50 AM                         | 0                          | 0    | 1     | 0 | 0                          | 1    | 0     | 0 | 0                        | 0    | 1     | 0 | 0                        | 1    | 0     | 0 | 4     | 22            |
| 9:55 AM                         | 0                          | 0    | 0     | 0 | 0                          | 0    | 0     | 0 | 0                        | 1    | 1     | 0 | 2                        | 0    | 0     | 0 | 4     | 22            |
| 10:00 AM                        | 1                          | 0    | 0     | 0 | 1                          | 0    | 0     | 0 | 0                        | 0    | 0     | 0 | 0                        | 0    | 1     | 0 | 3     | 24            |
| 10:05 AM                        | 0                          | 0    | 0     | 0 | 0                          | 0    | 0     | 0 | 0                        | 0    | 0     | 0 | 0                        | 0    | 0     | 0 | 0     | 22            |
| 10:10 AM                        | 0                          | 0    | 1     | 0 | 1                          | 0    | 0     | 0 | 0                        | 0    | 0     | 0 | 0                        | 0    | 0     | 0 | 2     | 22            |
| 10:15 AM                        | 1                          | 0    | 0     | 0 | 0                          | 0    | 0     | 0 | 0                        | 0    | 0     | 0 | 0                        | 0    | 0     | 0 | 1     | 23            |
| 10:20 AM                        | 0                          | 0    | 1     | 0 | 0                          | 0    | 0     | 0 | 0                        | 0    | 0     | 0 | 0                        | 0    | 0     | 0 | 1     | 23            |
| 10:25 AM                        | 0                          | 0    | 0     | 0 | 0                          | 0    | 0     | 0 | 0                        | 1    | 0     | 0 | 0                        | 0    | 0     | 0 | 1     | 21            |
| 10:30 AM                        | 0                          | 0    | 1     | 0 | 0                          | 0    | 0     | 0 | 1                        | 0    | 0     | 0 | 0                        | 0    | 0     | 0 | 2     | 22            |
| 10:35 AM                        | 1                          | 0    | 0     | 0 | 0                          | 0    | 0     | 0 | 0                        | 0    | 0     | 0 | 1                        | 0    | 0     | 0 | 2     | 24            |
| 10:40 AM                        | 1                          | 0    | 0     | 0 | 0                          | 0    | 0     | 0 | 0                        | 0    | 0     | 0 | 0                        | 0    | 0     | 0 | 1     | 25            |
| 10:45 AM                        | 0                          | 0    | 0     | 0 | 0                          | 0    | 0     | 0 | 0                        | 0    | 0     | 0 | 0                        | 0    | 0     | 0 | 0     | 21            |
| 10:50 AM                        | 0                          | 0    | 1     | 0 | 0                          | 0    | 0     | 0 | 0                        | 1    | 0     | 0 | 0                        | 0    | 0     | 0 | 2     | 19            |
| 10:55 AM                        | 0                          | 0    | 2     | 0 | 0                          | 0    | 0     | 0 | 0                        | 2    | 0     | 0 | 0                        | 1    | 0     | 0 | 5     | 20            |
| 11:00 AM                        | 1                          | 0    | 0     | 0 | 0                          | 1    | 0     | 0 | 0                        | 0    | 0     | 0 | 0                        | 0    | 0     | 0 | 2     | 19            |
| 11:05 AM                        | 0                          | 0    | 0     | 0 | 1                          | 0    | 0     | 0 | 0                        | 0    | 2     | 0 | 0                        | 0    | 0     | 0 | 3     | 22            |
| 11:10 AM                        | 0                          | 0    | 0     | 0 | 0                          | 0    | 0     | 0 | 0                        | 0    | 0     | 0 | 0                        | 0    | 0     | 0 | 0     | 20            |
| 11:15 AM                        | 0                          | 1    | 0     | 0 | 0                          | 0    | 0     | 0 | 0                        | 0    | 0     | 0 | 0                        | 0    | 0     | 0 | 1     | 20            |
| 11:20 AM                        | 0                          | 0    | 1     | 0 | 0                          | 0    | 0     | 0 | 0                        | 0    | 0     | 0 | 0                        | 1    | 1     | 0 | 3     | 22            |
| 11:25 AM                        | 0                          | 0    | 0     | 0 | 1                          | 0    | 0     | 0 | 0                        | 0    | 0     | 0 | 0                        | 0    | 0     | 0 | 1     | 22            |
| 11:30 AM                        | 0                          | 0    | 0     | 0 | 0                          | 0    | 0     | 0 | 0                        | 0    | 0     | 0 | 1                        | 0    | 0     | 0 | 1     | 21            |
| 11:35 AM                        | 0                          | 0    | 1     | 0 | 0                          | 0    | 0     | 0 | 0                        | 0    | 0     | 0 | 1                        | 0    | 0     | 0 | 2     | 21            |
| 11:40 AM                        | 0                          | 0    | 0     | 0 | 0                          | 0    | 0     | 0 | 0                        | 0    | 0     | 0 | 1                        | 0    | 1     | 0 | 2     | 22            |
| 11:45 AM                        | 0                          | 0    | 0     | 0 | 0                          | 0    | 0     | 0 | 0                        | 0    | 0     | 0 | 0                        | 1    | 0     | 0 | 1     | 23            |
| 11:50 AM                        | 0                          | 0    | 0     | 0 | 0                          | 0    | 0     | 0 | 0                        | 0    | 0     | 0 | 0                        | 0    | 0     | 0 | 0     | 21            |
| 11:55 AM                        | 0                          | 0    | 1     | 0 | 0                          | 0    | 1     | 0 | 0                        | 0    | 0     | 0 | 0                        | 0    | 1     | 0 | 3     | 19            |
| 12:00 PM                        | 0                          | 0    | 1     | 0 | 1                          | 0    | 0     | 0 | 0                        | 0    | 0     | 0 | 0                        | 1    | 0     | 0 | 3     | 20            |
| 12:05 PM                        | 0                          | 0    | 0     | 0 | 0                          | 0    | 0     | 0 | 0                        | 0    | 0     | 0 | 0                        | 0    | 0     | 0 | 0     | 17            |
| 12:10 PM                        | 0                          | 0    | 0     | 0 | 2                          | 0    | 0     | 0 | 0                        | 0    | 0     | 0 | 0                        | 0    | 1     | 0 | 3     | 20            |
| 12:15 PM                        | 0                          | 0    | 0     | 0 | 0                          | 0    | 0     | 0 | 0                        | 1    | 0     | 0 | 0                        | 1    | 0     | 0 | 2     | 21            |
| 12:20 PM                        | 1                          | 0    | 0     | 0 | 0                          | 1    | 0     | 0 | 0                        | 0    | 0     | 0 | 0                        | 0    | 1     | 0 | 3     | 21            |
| 12:25 PM                        | 0                          | 0    | 0     | 0 | 0                          | 0    | 0     | 0 | 0                        | 0    | 0     | 0 | 0                        | 0    | 1     | 0 | 1     | 21            |
| 12:30 PM                        | 0                          | 0    | 0     | 0 | 0                          | 0    | 0     | 0 | 0                        | 1    | 0     | 0 | 0                        | 0    | 0     | 0 | 1     | 21            |
| 12:35 PM                        | 1                          | 1    | 0     | 0 | 0                          | 0    | 0     | 0 | 0                        | 0    | 1     | 0 | 1                        | 0    | 0     | 0 | 4     | 23            |
| 12:40 PM                        | 0                          | 0    | 1     | 0 | 1                          | 0    | 0     | 0 | 0                        | 1    | 0     | 0 | 0                        | 0    | 0     | 0 | 3     | 24            |
| 12:45 PM                        | 0                          | 0    | 0     | 0 | 0                          | 0    | 0     | 0 | 0                        | 2    | 0     | 0 | 1                        | 1    | 1     | 0 | 5     | 28            |
| 12:50 PM                        | 0                          | 0    | 0     | 0 | 0                          | 0    | 0     | 0 | 0                        | 1    | 0     | 0 | 0                        | 0    | 0     | 0 | 1     | 29            |
| 12:55 PM                        | 0                          | 0    | 0     | 0 | 0                          | 1    | 0     | 0 | 0                        | 4    | 0     | 0 | 0                        | 1    | 0     | 0 | 6     | 32            |
| 1:00 PM                         | 1                          | 0    | 0     | 0 | 0                          | 0    | 0     | 0 | 0                        | 4    | 1     | 0 | 1                        | 1    | 1     | 0 | 9     | 38            |
| 1:05 PM                         | 0                          | 0    | 1     | 0 | 0                          | 0    | 0     | 0 | 0                        | 6    | 0     | 0 | 1                        | 0    | 0     | 0 | 8     | 46            |
| 1:10 PM                         | 0                          | 0    | 1     | 0 | 2                          | 0    | 0     | 0 | 0                        | 5    | 1     | 0 | 2                        | 1    | 2     | 0 | 14    | 57            |
| 1:15 PM                         | 0                          | 1    | 1     | 0 | 0                          | 0    | 1     | 0 | 0                        | 4    | 0     | 0 | 0                        | 3    | 0     | 0 | 10    | 65            |
| 1:20 PM                         | 0                          | 0    | 1     | 0 | 0                          | 0    | 0     | 0 | 0                        | 3    | 0     | 0 | 0                        | 1    | 0     | 0 | 5     | 67            |
| 1:25 PM                         | 1                          | 2    | 2     | 0 | 0                          | 1    | 0     | 0 | 0                        | 0    | 0     | 0 | 0                        | 9    | 0     | 0 | 15    | 81            |
| 1:30 PM                         | 0                          | 2    | 0     | 0 | 0                          | 1    | 0     | 0 | 1                        | 1    | 0     | 0 | 2                        | 4    | 0     | 0 | 11    | 91            |
| 1:35 PM                         | 0                          | 0    | 1     | 0 | 0                          | 1    | 0     | 0 | 0                        | 4    | 2     | 0 | 0                        | 2    | 0     | 0 | 10    | 97            |
| 1:40 PM                         | 0                          | 0    | 1     | 0 | 0                          | 0    | 0     | 0 | 0                        | 2    | 0     | 0 | 1                        | 1    | 0     | 0 | 5     | 99            |
| 1:45 PM                         | 1                          | 2    | 2     | 0 | 0                          | 0    | 0     | 0 | 0                        | 1    | 2     | 0 | 0                        | 0    | 0     | 0 | 8     | 102           |
| 1:50 PM                         | 1                          | 1    | 0     | 0 | 0                          | 0    | 0     | 0 | 0                        | 0    | 0     | 0 | 0                        | 0    | 0     | 0 | 2     | 103           |
| 1:55 PM                         | 0                          | 0    | 0     | 0 | 0                          | 0    | 0     | 0 | 0                        | 0    | 0     | 0 | 0                        | 0    | 0     | 0 | 0     | 97            |
| 2:00 PM                         | 0                          | 0    | 1     | 0 | 0                          | 0    | 0     | 0 | 0                        | 1    | 0     | 0 | 0                        | 0    | 0     | 0 | 2     | 90            |
| 2:05 PM                         | 0                          | 0    | 0     | 0 | 0                          | 1    | 0     | 0 | 0                        | 2    | 0     | 0 | 1                        | 1    | 0     | 0 | 5     | 87            |
| 2:10 PM                         | 0                          | 0    | 0     | 0 | 0                          | 1    | 1     | 0 | 0                        | 0    | 1     | 0 | 0                        | 0    | 0     | 0 | 3     | 76            |
| 2:15 PM                         | 0                          | 0    | 1     | 0 | 0                          | 0    | 0     | 0 | 0                        | 1    | 0     | 0 | 1                        | 0    | 0     | 0 | 3     | 69            |
| 2:20 PM                         | 0                          | 0    | 1     | 0 | 0                          | 0    | 0     | 0 | 0                        | 1    | 1     | 0 | 1                        | 0    | 1     | 0 | 5     | 69            |
| 2:25 PM                         | 0                          | 0    | 0     | 0 | 0                          | 0    | 0     | 0 | 0                        | 3    | 1     | 0 | 0                        | 0    | 0     | 0 | 4     | 58            |
| 2:30 PM                         | 0                          | 0    | 0     | 0 | 0                          | 0    | 0     | 0 | 0                        | 4    | 1     | 0 | 0                        | 1    | 0     | 0 | 6     | 53            |
| 2:35 PM                         | 0                          | 1    | 0     | 0 | 0                          | 0    | 0     | 0 | 0                        | 1    | 0     | 0 | 0                        | 0    | 1     | 0 | 3     | 46            |
| 2:40 PM                         | 0                          | 0    | 1     | 0 | 1                          | 0    | 0     | 0 | 1                        | 1    | 1     | 0 | 1                        | 3    | 0     | 0 | 9     | 50            |
| 2:45 PM                         | 0                          | 3    | 0     | 0 | 1                          | 1    | 0     | 0 | 0                        | 0    | 1     | 0 | 0                        | 2    | 0     | 0 | 8     | 50            |
| 2:50 PM                         | 1                          | 0    | 1     | 0 | 0                          | 0    | 0     | 0 | 0                        | 2    | 1     | 0 | 1                        | 0    | 0     | 0 | 6     | 54            |
| 2:55 PM                         | 0                          | 0    | 1     | 0 | 0                          | 0    | 1     | 0 | 0                        | 2    | 0     | 0 | 1                        | 0    | 1     | 0 | 6     | 60            |
| 3:00 PM                         | 0                          | 0    | 0     | 0 | 1                          | 0    | 0     | 0 | 0                        | 3    | 2     | 0 | 0                        | 1    | 0     | 0 | 7     | 65            |
| 3:05 PM                         | 1                          | 0    | 1     | 0 | 0                          | 0    | 0     | 0 | 0                        | 2    | 0     | 0 | 1                        | 0    | 0     | 0 | 5     | 65            |
| 3:10 PM                         | 0                          | 1    | 0     | 0 | 0                          | 0    | 0     | 0 | 0                        | 0    | 0     | 0 | 1                        | 1    | 0     | 0 | 3     | 65            |
| 3:15 PM                         | 0                          | 0    | 0     | 0 | 1                          | 0    | 0     | 0 | 0                        | 0    | 0     | 0 | 0                        | 1    | 0     | 0 | 2     | 64            |
| 3:20 PM                         | 0                          | 0    | 0     | 0 | 0                          | 0    | 0     | 0 | 0                        | 3    | 0     | 0 | 1                        | 1    | 0     | 0 | 5     | 64            |
| 3:25 PM                         | 0                          | 0    | 1     | 0 | 0                          | 1    | 0     | 0 | 0                        | 1    | 0     | 0 | 0                        | 0    | 0     | 0 | 3     | 63            |
| 3:30 PM                         | 0                          | 0    | 1     | 0 | 1                          | 0    | 0     | 0 | 0                        | 1    | 0     | 0 | 0                        | 1    | 0     | 0 | 4     | 61            |
| 3:35 PM                         | 0                          | 0    | 2     | 0 | 1                          | 0    | 0     | 0 | 0                        | 1    | 0     | 0 | 2                        | 3    | 1     | 0 | 10    | 68            |
| 3:40 PM                         | 1                          | 0    | 1     | 0 | 1                          | 0    | 0     | 0 | 2                        | 4    | 0     | 0 | 0                        | 1    | 0     | 0 | 10    | 69            |
| 3:45 PM                         | 0                          | 0    | 0     | 0 | 0                          | 1    | 0     | 0 | 0                        | 2    | 0     | 0 | 1                        | 1    | 0     | 0 | 5     | 66            |
| 3:50 PM                         | 0                          | 1    | 0     | 0 | 0                          | 0    | 0     | 0 | 0                        | 3    | 1     | 0 | 0                        | 3    | 0     | 0 | 8     | 68            |
| 3:55 PM                         | 0                          | 0    | 0     | 0 | 1                          | 0    | 0     | 0 | 0                        | 1    | 1     | 0 | 1                        | 3    | 0     | 0 | 7     | 69            |
| 4:00 PM                         | 0                          | 1    | 0     | 0 | 0                          | 0    | 0     | 0 | 0                        | 4    | 2     | 0 | 0                        | 1    | 0     | 0 | 8     | 70            |
| 4:05 PM                         | 0                          | 0    | 1     | 0 | 0                          | 0    | 1     | 0 | 0                        | 0    | 1     | 0 | 0                        | 1    | 0     | 0 | 4     | 69            |
| 4:10 PM                         | 0                          | 0    | 0     | 0 | 0                          | 0    | 0     | 0 | 0                        | 2    | 0     | 0 | 0                        | 0    | 1     | 0 | 3     | 69            |
| 4:15 PM                         | 0                          | 0    | 0     | 0 | 0                          | 0    | 0     | 0 | 0                        | 4    | 0     | 0 | 0                        | 0    | 0     | 0 | 4     | 71            |
| 4:20 PM                         | 0                          | 0    | 1     | 0 | 0                          | 0    | 0     | 0 | 0                        | 2    | 0     | 0 | 0                        | 0    | 0     | 0 | 3     | 69            |
| 4:25 PM                         | 1                          | 0    | 0     | 0 | 0                          | 0    | 0     | 0 | 0                        | 0    | 0     | 0 | 0                        | 0    | 1     | 0 | 2     | 68            |
| 4:30 PM                         | 0                          | 0    | 0     | 0 | 0                          | 0    | 0     | 0 | 0                        | 1    | 1     | 0 | 0                        | 1    | 1     | 0 | 4     | 68            |

**Attachment B**

| 5-Min Count Period Beginning At | Kensington Rd (Northbound) |      |       |   | Kensington Rd (Southbound) |      |       |   | Piedmont Ave (Eastbound) |      |       |   | Piedmont Ave (Westbound) |      |       |   | Total | Hourly Totals |
|---------------------------------|----------------------------|------|-------|---|----------------------------|------|-------|---|--------------------------|------|-------|---|--------------------------|------|-------|---|-------|---------------|
|                                 | Left                       | Thru | Right | U | Left                       | Thru | Right | U | Left                     | Thru | Right | U | Left                     | Thru | Right | U |       |               |
| 4:35 PM                         | 0                          | 0    | 0     | 0 | 1                          | 0    | 0     | 0 | 0                        | 0    | 0     | 0 | 0                        | 1    | 0     | 0 | 2     | 60            |
| 4:40 PM                         | 0                          | 0    | 0     | 0 | 1                          | 0    | 0     | 0 | 0                        | 0    | 1     | 1 | 0                        | 0    | 0     | 0 | 3     | 53            |
| 4:45 PM                         | 0                          | 0    | 0     | 0 | 0                          | 0    | 0     | 0 | 0                        | 4    | 1     | 0 | 0                        | 0    | 0     | 0 | 5     | 53            |
| 4:50 PM                         | 0                          | 0    | 0     | 0 | 1                          | 0    | 0     | 0 | 0                        | 0    | 1     | 0 | 0                        | 0    | 1     | 0 | 3     | 48            |
| 4:55 PM                         | 0                          | 0    | 0     | 0 | 0                          | 1    | 0     | 0 | 0                        | 0    | 4     | 0 | 0                        | 1    | 1     | 0 | 7     | 48            |
| 5:00 PM                         | 0                          | 0    | 0     | 0 | 0                          | 0    | 0     | 0 | 0                        | 0    | 1     | 0 | 0                        | 0    | 0     | 0 | 1     | 41            |
| 5:05 PM                         | 0                          | 0    | 1     | 0 | 0                          | 0    | 0     | 0 | 0                        | 2    | 0     | 0 | 0                        | 2    | 1     | 0 | 6     | 43            |
| 5:10 PM                         | 0                          | 0    | 0     | 0 | 0                          | 1    | 0     | 0 | 0                        | 0    | 3     | 0 | 0                        | 0    | 0     | 0 | 4     | 44            |
| 5:15 PM                         | 0                          | 0    | 0     | 0 | 1                          | 0    | 0     | 0 | 0                        | 0    | 0     | 1 | 0                        | 1    | 1     | 0 | 4     | 44            |
| 5:20 PM                         | 0                          | 0    | 0     | 0 | 0                          | 0    | 0     | 0 | 0                        | 0    | 1     | 1 | 0                        | 0    | 0     | 0 | 2     | 43            |
| 5:25 PM                         | 2                          | 0    | 1     | 0 | 1                          | 0    | 0     | 0 | 0                        | 0    | 1     | 1 | 0                        | 0    | 0     | 0 | 6     | 47            |
| 5:30 PM                         | 0                          | 0    | 1     | 0 | 0                          | 0    | 0     | 0 | 0                        | 0    | 0     | 0 | 0                        | 0    | 0     | 0 | 1     | 44            |
| 5:35 PM                         | 0                          | 1    | 0     | 0 | 0                          | 0    | 0     | 0 | 0                        | 0    | 1     | 0 | 1                        | 1    | 0     | 0 | 4     | 46            |
| 5:40 PM                         | 0                          | 0    | 0     | 0 | 1                          | 0    | 0     | 0 | 0                        | 0    | 1     | 0 | 0                        | 0    | 0     | 0 | 2     | 45            |
| 5:45 PM                         | 0                          | 0    | 0     | 0 | 0                          | 0    | 0     | 0 | 0                        | 0    | 0     | 1 | 0                        | 0    | 0     | 0 | 1     | 41            |
| 5:50 PM                         | 1                          | 0    | 0     | 0 | 0                          | 0    | 0     | 0 | 0                        | 0    | 0     | 0 | 0                        | 0    | 0     | 0 | 1     | 39            |
| 5:55 PM                         | 0                          | 0    | 0     | 0 | 0                          | 0    | 0     | 0 | 0                        | 0    | 0     | 0 | 0                        | 2    | 1     | 0 | 3     | 35            |
| 6:00 PM                         | 0                          | 0    | 0     | 0 | 0                          | 0    | 0     | 0 | 0                        | 0    | 0     | 0 | 0                        | 1    | 0     | 0 | 1     | 35            |
| 6:05 PM                         | 0                          | 0    | 0     | 0 | 1                          | 0    | 0     | 0 | 0                        | 0    | 1     | 1 | 0                        | 0    | 1     | 0 | 4     | 33            |
| 6:10 PM                         | 1                          | 0    | 0     | 0 | 1                          | 0    | 0     | 0 | 0                        | 0    | 0     | 0 | 0                        | 1    | 0     | 0 | 3     | 32            |
| 6:15 PM                         | 0                          | 0    | 0     | 0 | 0                          | 0    | 0     | 0 | 0                        | 2    | 0     | 0 | 0                        | 0    | 0     | 0 | 2     | 30            |
| 6:20 PM                         | 0                          | 1    | 0     | 0 | 0                          | 0    | 0     | 0 | 0                        | 0    | 0     | 0 | 0                        | 0    | 0     | 0 | 1     | 29            |
| 6:25 PM                         | 0                          | 1    | 0     | 0 | 1                          | 0    | 0     | 0 | 0                        | 0    | 1     | 0 | 0                        | 0    | 0     | 0 | 3     | 26            |
| 6:30 PM                         | 0                          | 0    | 1     | 0 | 0                          | 0    | 0     | 0 | 0                        | 0    | 1     | 0 | 0                        | 0    | 0     | 0 | 2     | 27            |
| 6:35 PM                         | 0                          | 0    | 0     | 0 | 0                          | 0    | 0     | 0 | 0                        | 0    | 1     | 0 | 0                        | 1    | 1     | 0 | 3     | 26            |
| 6:40 PM                         | 0                          | 0    | 0     | 0 | 1                          | 0    | 0     | 0 | 0                        | 0    | 0     | 0 | 0                        | 0    | 1     | 0 | 2     | 26            |
| 6:45 PM                         | 0                          | 0    | 0     | 0 | 0                          | 0    | 0     | 0 | 0                        | 0    | 1     | 0 | 0                        | 0    | 0     | 0 | 1     | 26            |
| 6:50 PM                         | 0                          | 0    | 0     | 0 | 0                          | 0    | 0     | 0 | 0                        | 0    | 0     | 0 | 0                        | 1    | 0     | 0 | 1     | 26            |
| 6:55 PM                         | 0                          | 0    | 0     | 0 | 0                          | 0    | 0     | 0 | 0                        | 0    | 1     | 0 | 0                        | 1    | 0     | 0 | 2     | 25            |
| 7:00 PM                         | 0                          | 0    | 0     | 0 | 0                          | 0    | 0     | 0 | 0                        | 0    | 0     | 0 | 0                        | 1    | 0     | 0 | 1     | 25            |
| 7:05 PM                         | 0                          | 0    | 0     | 0 | 0                          | 0    | 0     | 0 | 0                        | 0    | 1     | 0 | 0                        | 0    | 0     | 1 | 2     | 23            |
| 7:10 PM                         | 0                          | 1    | 1     | 0 | 0                          | 0    | 0     | 0 | 0                        | 0    | 0     | 0 | 0                        | 0    | 0     | 0 | 2     | 22            |
| 7:15 PM                         | 0                          | 0    | 0     | 0 | 0                          | 0    | 0     | 0 | 0                        | 0    | 0     | 0 | 0                        | 0    | 0     | 0 | 0     | 20            |
| 7:20 PM                         | 0                          | 0    | 0     | 0 | 0                          | 0    | 0     | 0 | 0                        | 0    | 0     | 0 | 0                        | 0    | 1     | 0 | 1     | 20            |
| 7:25 PM                         | 0                          | 0    | 0     | 0 | 0                          | 0    | 0     | 0 | 0                        | 0    | 0     | 1 | 0                        | 0    | 0     | 0 | 1     | 18            |
| 7:30 PM                         | 0                          | 0    | 0     | 0 | 0                          | 0    | 0     | 0 | 0                        | 0    | 0     | 0 | 0                        | 0    | 0     | 0 | 0     | 16            |
| 7:35 PM                         | 0                          | 0    | 0     | 0 | 0                          | 0    | 0     | 0 | 0                        | 0    | 1     | 1 | 0                        | 0    | 0     | 0 | 2     | 15            |
| 7:40 PM                         | 0                          | 0    | 0     | 0 | 0                          | 0    | 0     | 0 | 0                        | 0    | 0     | 0 | 0                        | 0    | 2     | 0 | 2     | 15            |
| 7:45 PM                         | 0                          | 1    | 0     | 0 | 0                          | 0    | 0     | 0 | 0                        | 1    | 0     | 0 | 0                        | 0    | 0     | 0 | 2     | 16            |
| 7:50 PM                         | 0                          | 0    | 0     | 0 | 0                          | 0    | 0     | 0 | 0                        | 0    | 0     | 0 | 0                        | 0    | 0     | 0 | 0     | 15            |
| 7:55 PM                         | 0                          | 0    | 0     | 0 | 0                          | 0    | 0     | 0 | 0                        | 0    | 0     | 0 | 0                        | 0    | 0     | 1 | 1     | 14            |
| 8:00 PM                         | 0                          | 0    | 0     | 0 | 0                          | 0    | 1     | 0 | 0                        | 0    | 0     | 0 | 0                        | 0    | 0     | 0 | 1     | 14            |
| 8:05 PM                         | 0                          | 0    | 0     | 0 | 0                          | 0    | 0     | 0 | 0                        | 0    | 0     | 0 | 0                        | 0    | 1     | 0 | 1     | 13            |
| 8:10 PM                         | 0                          | 0    | 0     | 0 | 0                          | 0    | 0     | 0 | 0                        | 0    | 0     | 0 | 0                        | 0    | 0     | 0 | 0     | 11            |
| 8:15 PM                         | 0                          | 1    | 0     | 0 | 0                          | 0    | 0     | 0 | 0                        | 0    | 0     | 1 | 0                        | 0    | 0     | 2 | 4     | 15            |
| 8:20 PM                         | 1                          | 0    | 0     | 0 | 0                          | 0    | 0     | 0 | 0                        | 0    | 0     | 0 | 0                        | 0    | 0     | 0 | 1     | 15            |
| 8:25 PM                         | 0                          | 0    | 0     | 0 | 0                          | 0    | 1     | 0 | 0                        | 0    | 0     | 0 | 0                        | 0    | 0     | 0 | 1     | 15            |
| 8:30 PM                         | 0                          | 0    | 0     | 0 | 0                          | 0    | 0     | 0 | 0                        | 0    | 0     | 0 | 0                        | 0    | 0     | 0 | 0     | 15            |
| 8:35 PM                         | 0                          | 0    | 1     | 0 | 0                          | 0    | 0     | 0 | 0                        | 0    | 0     | 0 | 0                        | 0    | 0     | 0 | 1     | 14            |
| 8:40 PM                         | 0                          | 0    | 0     | 0 | 0                          | 0    | 0     | 0 | 0                        | 0    | 0     | 0 | 0                        | 0    | 0     | 0 | 0     | 12            |
| 8:45 PM                         | 0                          | 0    | 0     | 0 | 0                          | 0    | 0     | 0 | 0                        | 0    | 0     | 0 | 0                        | 0    | 0     | 0 | 0     | 10            |
| 8:50 PM                         | 0                          | 0    | 1     | 0 | 0                          | 0    | 0     | 0 | 0                        | 0    | 0     | 0 | 0                        | 0    | 0     | 0 | 1     | 11            |
| 8:55 PM                         | 0                          | 0    | 0     | 0 | 0                          | 0    | 0     | 0 | 0                        | 0    | 0     | 0 | 0                        | 0    | 0     | 0 | 0     | 10            |
| 9:00 PM                         | 0                          | 0    | 0     | 0 | 1                          | 0    | 0     | 0 | 0                        | 0    | 0     | 0 | 0                        | 0    | 0     | 0 | 1     | 10            |
| 9:05 PM                         | 0                          | 1    | 0     | 0 | 0                          | 0    | 0     | 0 | 0                        | 0    | 0     | 0 | 0                        | 1    | 0     | 0 | 2     | 11            |
| 9:10 PM                         | 0                          | 1    | 0     | 0 | 0                          | 0    | 0     | 0 | 0                        | 0    | 0     | 0 | 0                        | 1    | 0     | 0 | 2     | 13            |
| 9:15 PM                         | 0                          | 0    | 0     | 0 | 1                          | 0    | 0     | 0 | 0                        | 0    | 2     | 0 | 0                        | 0    | 0     | 0 | 3     | 12            |
| 9:20 PM                         | 0                          | 0    | 0     | 0 | 0                          | 0    | 0     | 0 | 0                        | 0    | 0     | 0 | 0                        | 0    | 0     | 0 | 0     | 11            |
| 9:25 PM                         | 0                          | 0    | 0     | 0 | 0                          | 0    | 0     | 0 | 0                        | 0    | 0     | 0 | 0                        | 0    | 0     | 0 | 0     | 10            |
| 9:30 PM                         | 0                          | 1    | 0     | 0 | 0                          | 0    | 0     | 0 | 0                        | 0    | 0     | 0 | 0                        | 0    | 0     | 0 | 1     | 11            |
| 9:35 PM                         | 0                          | 0    | 0     | 0 | 0                          | 0    | 0     | 0 | 0                        | 0    | 0     | 0 | 0                        | 0    | 0     | 0 | 0     | 10            |
| 9:40 PM                         | 0                          | 0    | 0     | 0 | 0                          | 0    | 0     | 0 | 0                        | 0    | 0     | 0 | 0                        | 0    | 0     | 0 | 0     | 10            |
| 9:45 PM                         | 0                          | 0    | 0     | 0 | 0                          | 0    | 0     | 0 | 0                        | 1    | 0     | 0 | 0                        | 0    | 0     | 0 | 1     | 11            |
| 9:50 PM                         | 0                          | 0    | 0     | 0 | 0                          | 0    | 0     | 0 | 0                        | 0    | 1     | 0 | 0                        | 0    | 0     | 0 | 1     | 11            |
| 9:55 PM                         | 0                          | 0    | 0     | 0 | 0                          | 0    | 0     | 0 | 0                        | 0    | 1     | 0 | 0                        | 0    | 0     | 0 | 1     | 12            |
| Peak 15-Min Flowrates           | Northbound                 |      |       |   | Southbound                 |      |       |   | Eastbound                |      |       |   | Westbound                |      |       |   | Total |               |
|                                 | Left                       | Thru | Right | U | Left                       | Thru | Right | U | Left                     | Thru | Right | U | Left                     | Thru | Right | U |       |               |
| All Vehicles                    | 8                          | 4    | 12    | 0 | 4                          | 0    | 4     | 0 | 8                        | 224  | 0     | 0 | 24                       | 76   | 0     | 0 | 364   |               |
| Heavy Trucks                    | 0                          | 0    | 0     | 0 | 0                          | 0    | 0     | 0 | 0                        | 0    | 0     | 0 | 0                        | 0    | 0     | 0 | 0     |               |
| Buses                           |                            |      |       |   |                            |      |       |   |                          |      |       |   |                          |      |       |   |       |               |
| Pedestrians                     |                            | 8    |       |   |                            | 0    |       |   |                          | 8    |       |   |                          | 0    |       |   | 16    |               |
| Bicycles                        | 0                          | 0    | 0     |   | 0                          | 0    | 0     |   | 0                        | 0    | 0     |   | 0                        | 0    | 0     |   | 0     |               |
| Scoters                         |                            |      |       |   |                            |      |       |   |                          |      |       |   |                          |      |       |   |       |               |
| <i>Comments:</i>                |                            |      |       |   |                            |      |       |   |                          |      |       |   |                          |      |       |   |       |               |

LOCATION: Argyle Dr -- Oak Knoll Dr  
 CITY/STATE: Rossmore, CA

QC JOB #: 16966423  
 DATE: Wed, Apr 9 2025

Peak-Hour: 7:55 AM -- 8:55 AM  
 Peak 15-Min: 8:00 AM -- 8:15 AM

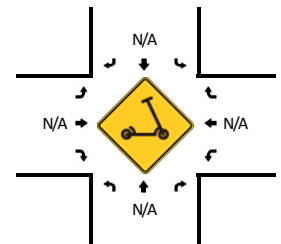
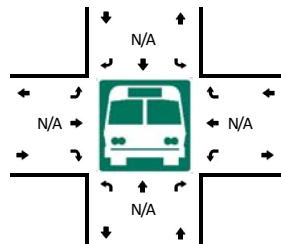
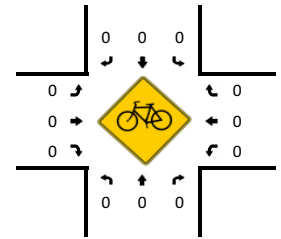
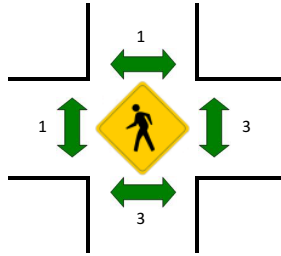
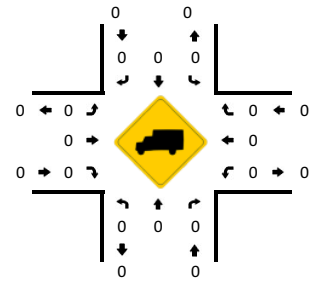
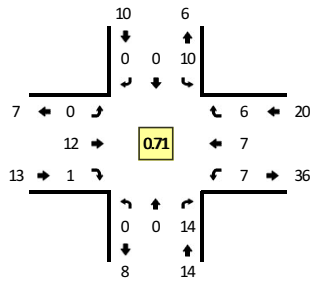

| 5-Min Count Period Beginning At | Argyle Dr (Northbound) |      |       |   | Argyle Dr (Southbound) |      |       |   | Oak Knoll Dr (Eastbound) |      |       |   | Oak Knoll Dr (Westbound) |      |       |   | Total | Hourly Totals |
|---------------------------------|------------------------|------|-------|---|------------------------|------|-------|---|--------------------------|------|-------|---|--------------------------|------|-------|---|-------|---------------|
|                                 | Left                   | Thru | Right | U | Left                   | Thru | Right | U | Left                     | Thru | Right | U | Left                     | Thru | Right | U |       |               |
| 6:00 AM                         | 0                      | 0    | 1     | 0 | 0                      | 0    | 0     | 0 | 0                        | 0    | 0     | 0 | 0                        | 0    | 0     | 0 | 1     |               |
| 6:05 AM                         | 0                      | 0    | 0     | 0 | 0                      | 0    | 0     | 0 | 0                        | 0    | 0     | 0 | 0                        | 0    | 0     | 0 | 0     |               |
| 6:10 AM                         | 0                      | 0    | 0     | 0 | 1                      | 0    | 0     | 0 | 0                        | 0    | 0     | 0 | 0                        | 0    | 0     | 0 | 1     |               |
| 6:15 AM                         | 0                      | 0    | 0     | 0 | 0                      | 0    | 0     | 0 | 0                        | 0    | 0     | 0 | 0                        | 0    | 1     | 0 | 1     |               |
| 6:20 AM                         | 0                      | 0    | 1     | 0 | 0                      | 0    | 0     | 0 | 0                        | 0    | 0     | 0 | 1                        | 0    | 0     | 0 | 2     |               |
| 6:25 AM                         | 0                      | 0    | 0     | 0 | 0                      | 0    | 0     | 0 | 0                        | 1    | 0     | 0 | 1                        | 0    | 0     | 0 | 2     |               |
| 6:30 AM                         | 0                      | 0    | 2     | 0 | 0                      | 0    | 0     | 0 | 0                        | 0    | 0     | 0 | 0                        | 1    | 0     | 0 | 3     |               |
| 6:35 AM                         | 0                      | 0    | 0     | 0 | 1                      | 0    | 0     | 0 | 0                        | 0    | 1     | 0 | 0                        | 0    | 0     | 0 | 2     |               |
| 6:40 AM                         | 0                      | 0    | 1     | 0 | 0                      | 0    | 0     | 0 | 0                        | 0    | 0     | 0 | 0                        | 0    | 0     | 0 | 1     |               |
| 6:45 AM                         | 0                      | 0    | 0     | 0 | 0                      | 0    | 0     | 0 | 0                        | 0    | 0     | 0 | 1                        | 0    | 0     | 0 | 1     |               |
| 6:50 AM                         | 0                      | 0    | 1     | 0 | 1                      | 0    | 0     | 0 | 0                        | 0    | 1     | 0 | 1                        | 0    | 0     | 0 | 4     |               |
| 6:55 AM                         | 0                      | 0    | 0     | 0 | 0                      | 0    | 0     | 0 | 0                        | 0    | 0     | 0 | 0                        | 0    | 0     | 0 | 0     | 18            |
| 7:00 AM                         | 0                      | 0    | 0     | 0 | 1                      | 0    | 0     | 0 | 0                        | 0    | 0     | 0 | 0                        | 0    | 1     | 0 | 2     | 19            |
| 7:05 AM                         | 0                      | 0    | 1     | 0 | 0                      | 0    | 0     | 0 | 0                        | 0    | 0     | 0 | 0                        | 1    | 0     | 0 | 2     | 21            |
| 7:10 AM                         | 0                      | 0    | 0     | 0 | 0                      | 0    | 0     | 0 | 0                        | 1    | 0     | 0 | 0                        | 0    | 0     | 0 | 1     | 21            |
| 7:15 AM                         | 0                      | 0    | 0     | 0 | 1                      | 0    | 0     | 0 | 0                        | 1    | 0     | 0 | 0                        | 0    | 0     | 0 | 2     | 22            |
| 7:20 AM                         | 0                      | 0    | 0     | 0 | 2                      | 0    | 0     | 0 | 0                        | 0    | 0     | 0 | 0                        | 0    | 1     | 0 | 3     | 23            |
| 7:25 AM                         | 0                      | 0    | 1     | 0 | 0                      | 0    | 0     | 0 | 0                        | 0    | 0     | 0 | 0                        | 0    | 0     | 0 | 1     | 22            |
| 7:30 AM                         | 0                      | 0    | 0     | 0 | 3                      | 0    | 0     | 0 | 0                        | 0    | 0     | 0 | 0                        | 0    | 0     | 0 | 3     | 22            |
| 7:35 AM                         | 0                      | 0    | 1     | 0 | 0                      | 0    | 0     | 0 | 0                        | 1    | 0     | 0 | 0                        | 0    | 0     | 0 | 2     | 22            |
| 7:40 AM                         | 0                      | 0    | 0     | 0 | 0                      | 0    | 0     | 0 | 0                        | 3    | 0     | 0 | 0                        | 0    | 0     | 0 | 3     | 24            |
| 7:45 AM                         | 0                      | 0    | 1     | 0 | 1                      | 0    | 0     | 0 | 0                        | 0    | 0     | 0 | 1                        | 0    | 1     | 0 | 4     | 27            |
| 7:50 AM                         | 0                      | 0    | 0     | 0 | 2                      | 0    | 0     | 0 | 0                        | 0    | 0     | 0 | 1                        | 0    | 0     | 0 | 3     | 26            |
| 7:55 AM                         | 0                      | 0    | 0     | 0 | 1                      | 0    | 0     | 0 | 0                        | 0    | 2     | 0 | 2                        | 1    | 0     | 0 | 6     | 32            |
| 8:00 AM                         | 0                      | 0    | 2     | 0 | 1                      | 0    | 0     | 0 | 0                        | 0    | 2     | 0 | 0                        | 1    | 0     | 0 | 6     | 36            |
| 8:05 AM                         | 0                      | 0    | 1     | 0 | 0                      | 0    | 0     | 0 | 0                        | 0    | 1     | 0 | 0                        | 2    | 0     | 0 | 4     | 38            |
| 8:10 AM                         | 0                      | 0    | 3     | 0 | 0                      | 0    | 0     | 0 | 0                        | 0    | 2     | 0 | 1                        | 0    | 4     | 0 | 10    | 47            |
| 8:15 AM                         | 0                      | 0    | 1     | 0 | 0                      | 0    | 0     | 0 | 0                        | 0    | 0     | 0 | 0                        | 0    | 0     | 0 | 1     | 46            |
| 8:20 AM                         | 0                      | 0    | 0     | 0 | 4                      | 0    | 0     | 0 | 0                        | 0    | 1     | 0 | 0                        | 0    | 0     | 0 | 5     | 48            |
| 8:25 AM                         | 0                      | 0    | 2     | 0 | 0                      | 0    | 0     | 0 | 0                        | 1    | 1     | 0 | 0                        | 0    | 0     | 0 | 4     | 51            |
| 8:30 AM                         | 0                      | 0    | 2     | 0 | 0                      | 0    | 0     | 0 | 0                        | 0    | 0     | 0 | 0                        | 0    | 0     | 0 | 2     | 50            |
| 8:35 AM                         | 0                      | 0    | 2     | 0 | 0                      | 0    | 0     | 0 | 0                        | 1    | 0     | 0 | 2                        | 0    | 0     | 0 | 5     | 53            |
| 8:40 AM                         | 0                      | 0    | 0     | 0 | 1                      | 0    | 0     | 0 | 0                        | 0    | 0     | 0 | 1                        | 2    | 1     | 0 | 5     | 55            |
| 8:45 AM                         | 0                      | 0    | 1     | 0 | 1                      | 0    | 0     | 0 | 0                        | 2    | 0     | 0 | 0                        | 0    | 0     | 0 | 4     | 55            |
| 8:50 AM                         | 0                      | 0    | 0     | 0 | 2                      | 0    | 0     | 0 | 0                        | 0    | 0     | 0 | 1                        | 1    | 1     | 0 | 5     | 57            |
| 8:55 AM                         | 0                      | 0    | 0     | 0 | 0                      | 0    | 0     | 0 | 0                        | 0    | 0     | 0 | 1                        | 0    | 0     | 0 | 1     | 52            |
| 9:00 AM                         | 0                      | 0    | 1     | 0 | 0                      | 0    | 0     | 0 | 0                        | 0    | 0     | 0 | 0                        | 0    | 1     | 0 | 2     | 48            |
| 9:05 AM                         | 0                      | 0    | 1     | 0 | 0                      | 0    | 0     | 0 | 0                        | 0    | 0     | 0 | 0                        | 0    | 0     | 0 | 1     | 45            |

**Attachment B**

| 5-Min Count Period Beginning At | Argyle Dr (Northbound) |      |       |   | Argyle Dr (Southbound) |      |       |   | Oak Knoll Dr (Eastbound) |      |       |   | Oak Knoll Dr (Westbound) |      |       |   | Total | Hourly Totals |
|---------------------------------|------------------------|------|-------|---|------------------------|------|-------|---|--------------------------|------|-------|---|--------------------------|------|-------|---|-------|---------------|
|                                 | Left                   | Thru | Right | U | Left                   | Thru | Right | U | Left                     | Thru | Right | U | Left                     | Thru | Right | U |       |               |
| 9:10 AM                         | 0                      | 0    | 2     | 0 | 2                      | 0    | 0     | 0 | 0                        | 0    | 0     | 0 | 0                        | 0    | 2     | 0 | 6     | 41            |
| 9:15 AM                         | 0                      | 0    | 0     | 0 | 0                      | 0    | 0     | 0 | 0                        | 0    | 0     | 0 | 1                        | 0    | 0     | 0 | 1     | 41            |
| 9:20 AM                         | 0                      | 0    | 1     | 0 | 0                      | 0    | 0     | 0 | 0                        | 0    | 0     | 0 | 0                        | 0    | 2     | 0 | 3     | 39            |
| 9:25 AM                         | 0                      | 0    | 2     | 0 | 1                      | 0    | 0     | 0 | 0                        | 0    | 0     | 0 | 0                        | 0    | 1     | 0 | 4     | 39            |
| 9:30 AM                         | 0                      | 0    | 2     | 0 | 1                      | 0    | 0     | 0 | 0                        | 0    | 0     | 0 | 0                        | 0    | 0     | 0 | 3     | 40            |
| 9:35 AM                         | 0                      | 0    | 1     | 0 | 0                      | 0    | 0     | 0 | 0                        | 0    | 0     | 0 | 0                        | 0    | 0     | 0 | 1     | 36            |
| 9:40 AM                         | 0                      | 0    | 1     | 0 | 0                      | 0    | 0     | 0 | 0                        | 0    | 0     | 0 | 3                        | 0    | 0     | 0 | 4     | 35            |
| 9:45 AM                         | 0                      | 0    | 0     | 0 | 0                      | 0    | 0     | 0 | 0                        | 1    | 0     | 0 | 0                        | 0    | 1     | 0 | 2     | 33            |
| 9:50 AM                         | 0                      | 0    | 2     | 0 | 0                      | 0    | 1     | 0 | 0                        | 0    | 1     | 0 | 0                        | 0    | 0     | 0 | 5     | 33            |
| 9:55 AM                         | 0                      | 1    | 0     | 0 | 1                      | 0    | 0     | 0 | 0                        | 4    | 0     | 0 | 0                        | 1    | 0     | 0 | 7     | 39            |
| 10:00 AM                        | 0                      | 0    | 1     | 0 | 0                      | 0    | 0     | 0 | 0                        | 0    | 0     | 0 | 1                        | 0    | 1     | 0 | 3     | 40            |
| 10:05 AM                        | 0                      | 0    | 2     | 0 | 1                      | 0    | 0     | 0 | 0                        | 1    | 0     | 0 | 0                        | 0    | 0     | 0 | 4     | 43            |
| 10:10 AM                        | 0                      | 0    | 0     | 0 | 0                      | 0    | 0     | 0 | 0                        | 1    | 0     | 0 | 0                        | 1    | 1     | 0 | 3     | 40            |
| 10:15 AM                        | 0                      | 0    | 1     | 0 | 1                      | 0    | 0     | 0 | 0                        | 1    | 0     | 0 | 0                        | 0    | 0     | 0 | 3     | 42            |
| 10:20 AM                        | 0                      | 0    | 0     | 0 | 0                      | 0    | 0     | 0 | 0                        | 1    | 0     | 0 | 1                        | 0    | 0     | 0 | 2     | 41            |
| 10:25 AM                        | 0                      | 0    | 0     | 0 | 0                      | 0    | 0     | 0 | 0                        | 1    | 0     | 0 | 1                        | 1    | 0     | 0 | 3     | 40            |
| 10:30 AM                        | 0                      | 0    | 0     | 0 | 0                      | 0    | 0     | 0 | 0                        | 2    | 0     | 0 | 0                        | 0    | 0     | 0 | 2     | 39            |
| 10:35 AM                        | 0                      | 0    | 1     | 0 | 0                      | 0    | 0     | 0 | 0                        | 0    | 0     | 0 | 0                        | 1    | 1     | 0 | 3     | 41            |
| 10:40 AM                        | 0                      | 0    | 0     | 0 | 3                      | 0    | 0     | 0 | 0                        | 0    | 0     | 0 | 0                        | 0    | 0     | 0 | 3     | 40            |
| 10:45 AM                        | 0                      | 0    | 0     | 0 | 2                      | 0    | 0     | 0 | 0                        | 0    | 0     | 0 | 1                        | 1    | 1     | 0 | 5     | 43            |
| 10:50 AM                        | 0                      | 0    | 0     | 0 | 2                      | 0    | 0     | 0 | 0                        | 0    | 0     | 0 | 0                        | 0    | 1     | 0 | 3     | 41            |
| 10:55 AM                        | 0                      | 0    | 0     | 0 | 2                      | 0    | 0     | 0 | 0                        | 1    | 0     | 0 | 0                        | 1    | 0     | 0 | 4     | 38            |
| 11:00 AM                        | 0                      | 0    | 0     | 0 | 0                      | 0    | 0     | 0 | 0                        | 0    | 0     | 0 | 0                        | 0    | 1     | 0 | 1     | 36            |
| 11:05 AM                        | 0                      | 0    | 0     | 0 | 0                      | 0    | 0     | 0 | 0                        | 0    | 0     | 0 | 0                        | 0    | 0     | 0 | 0     | 32            |
| 11:10 AM                        | 0                      | 0    | 1     | 0 | 1                      | 0    | 0     | 0 | 0                        | 0    | 0     | 0 | 0                        | 1    | 0     | 0 | 3     | 32            |
| 11:15 AM                        | 0                      | 0    | 0     | 0 | 0                      | 0    | 0     | 0 | 0                        | 0    | 0     | 0 | 0                        | 1    | 2     | 0 | 3     | 32            |
| 11:20 AM                        | 0                      | 1    | 0     | 0 | 0                      | 0    | 0     | 0 | 0                        | 2    | 0     | 0 | 0                        | 0    | 0     | 0 | 3     | 33            |
| 11:25 AM                        | 0                      | 0    | 0     | 0 | 0                      | 0    | 0     | 0 | 0                        | 0    | 0     | 0 | 0                        | 0    | 0     | 0 | 0     | 30            |
| 11:30 AM                        | 0                      | 0    | 1     | 0 | 1                      | 0    | 0     | 0 | 0                        | 1    | 0     | 0 | 1                        | 0    | 1     | 0 | 5     | 33            |
| 11:35 AM                        | 0                      | 0    | 0     | 0 | 1                      | 0    | 0     | 0 | 0                        | 0    | 0     | 0 | 0                        | 1    | 0     | 0 | 2     | 32            |
| 11:40 AM                        | 0                      | 0    | 1     | 0 | 0                      | 0    | 0     | 0 | 0                        | 0    | 0     | 0 | 1                        | 0    | 1     | 0 | 3     | 32            |
| 11:45 AM                        | 0                      | 0    | 0     | 0 | 1                      | 0    | 0     | 0 | 0                        | 0    | 0     | 0 | 1                        | 1    | 1     | 0 | 4     | 31            |
| 11:50 AM                        | 0                      | 0    | 1     | 0 | 0                      | 0    | 0     | 0 | 0                        | 1    | 1     | 0 | 0                        | 0    | 2     | 0 | 5     | 33            |
| 11:55 AM                        | 0                      | 0    | 1     | 0 | 0                      | 0    | 0     | 0 | 0                        | 1    | 0     | 0 | 1                        | 0    | 0     | 0 | 3     | 32            |
| 12:00 PM                        | 0                      | 0    | 0     | 0 | 0                      | 0    | 0     | 0 | 0                        | 1    | 1     | 0 | 0                        | 1    | 0     | 0 | 3     | 34            |
| 12:05 PM                        | 0                      | 0    | 1     | 0 | 0                      | 0    | 0     | 0 | 0                        | 0    | 0     | 0 | 0                        | 0    | 0     | 0 | 1     | 35            |
| 12:10 PM                        | 0                      | 0    | 1     | 0 | 2                      | 0    | 0     | 0 | 0                        | 0    | 0     | 0 | 1                        | 0    | 0     | 0 | 4     | 36            |
| 12:15 PM                        | 0                      | 0    | 0     | 0 | 0                      | 0    | 0     | 0 | 0                        | 0    | 0     | 0 | 0                        | 0    | 0     | 0 | 0     | 33            |
| 12:20 PM                        | 0                      | 0    | 1     | 0 | 0                      | 0    | 0     | 0 | 0                        | 0    | 0     | 0 | 0                        | 0    | 2     | 0 | 3     | 33            |
| 12:25 PM                        | 0                      | 0    | 0     | 0 | 0                      | 0    | 0     | 0 | 0                        | 1    | 0     | 0 | 0                        | 0    | 1     | 0 | 2     | 35            |
| 12:30 PM                        | 0                      | 0    | 1     | 0 | 1                      | 0    | 0     | 0 | 0                        | 0    | 0     | 0 | 0                        | 0    | 0     | 0 | 2     | 32            |
| 12:35 PM                        | 0                      | 0    | 0     | 0 | 0                      | 0    | 0     | 0 | 0                        | 0    | 0     | 0 | 0                        | 0    | 1     | 0 | 1     | 31            |
| 12:40 PM                        | 0                      | 0    | 2     | 0 | 1                      | 0    | 0     | 0 | 0                        | 0    | 0     | 0 | 1                        | 0    | 2     | 0 | 6     | 34            |
| 12:45 PM                        | 0                      | 0    | 1     | 0 | 0                      | 0    | 0     | 0 | 0                        | 0    | 0     | 0 | 2                        | 1    | 0     | 0 | 4     | 34            |
| 12:50 PM                        | 1                      | 0    | 0     | 0 | 0                      | 0    | 0     | 0 | 0                        | 1    | 0     | 0 | 0                        | 1    | 1     | 0 | 4     | 33            |
| 12:55 PM                        | 0                      | 0    | 0     | 0 | 0                      | 0    | 0     | 0 | 0                        | 0    | 0     | 0 | 2                        | 1    | 0     | 0 | 3     | 33            |
| 1:00 PM                         | 0                      | 0    | 0     | 0 | 1                      | 0    | 0     | 0 | 0                        | 2    | 0     | 0 | 0                        | 0    | 2     | 0 | 5     | 35            |
| 1:05 PM                         | 0                      | 0    | 0     | 0 | 0                      | 0    | 0     | 0 | 0                        | 2    | 0     | 0 | 0                        | 1    | 0     | 0 | 3     | 37            |
| 1:10 PM                         | 0                      | 0    | 1     | 0 | 0                      | 0    | 0     | 0 | 0                        | 0    | 0     | 0 | 0                        | 0    | 1     | 0 | 2     | 35            |
| 1:15 PM                         | 0                      | 0    | 0     | 0 | 1                      | 0    | 0     | 0 | 0                        | 0    | 0     | 0 | 0                        | 0    | 0     | 0 | 1     | 36            |
| 1:20 PM                         | 0                      | 0    | 0     | 0 | 2                      | 0    | 0     | 0 | 0                        | 2    | 0     | 0 | 0                        | 0    | 0     | 0 | 4     | 37            |
| 1:25 PM                         | 0                      | 0    | 1     | 0 | 2                      | 0    | 0     | 0 | 0                        | 2    | 0     | 0 | 1                        | 1    | 3     | 0 | 10    | 45            |
| 1:30 PM                         | 0                      | 0    | 0     | 0 | 0                      | 0    | 0     | 0 | 0                        | 0    | 0     | 0 | 0                        | 0    | 1     | 0 | 1     | 44            |
| 1:35 PM                         | 0                      | 0    | 0     | 0 | 0                      | 0    | 0     | 0 | 0                        | 1    | 0     | 0 | 1                        | 0    | 0     | 0 | 2     | 45            |
| 1:40 PM                         | 0                      | 0    | 1     | 0 | 1                      | 0    | 0     | 0 | 1                        | 0    | 0     | 0 | 1                        | 0    | 3     | 0 | 7     | 46            |
| 1:45 PM                         | 0                      | 0    | 0     | 0 | 0                      | 0    | 0     | 0 | 0                        | 2    | 0     | 0 | 1                        | 1    | 0     | 0 | 4     | 46            |
| 1:50 PM                         | 0                      | 0    | 1     | 0 | 1                      | 0    | 0     | 0 | 0                        | 0    | 0     | 0 | 2                        | 0    | 0     | 0 | 4     | 46            |
| 1:55 PM                         | 0                      | 0    | 2     | 0 | 1                      | 0    | 0     | 0 | 0                        | 1    | 0     | 0 | 0                        | 1    | 0     | 0 | 5     | 48            |
| 2:00 PM                         | 0                      | 0    | 0     | 0 | 1                      | 0    | 0     | 0 | 0                        | 0    | 0     | 0 | 0                        | 1    | 1     | 0 | 3     | 46            |
| 2:05 PM                         | 0                      | 0    | 2     | 0 | 0                      | 0    | 0     | 0 | 0                        | 0    | 0     | 0 | 1                        | 1    | 0     | 0 | 4     | 47            |
| 2:10 PM                         | 0                      | 0    | 0     | 0 | 1                      | 0    | 0     | 0 | 0                        | 1    | 0     | 0 | 0                        | 0    | 0     | 0 | 2     | 47            |
| 2:15 PM                         | 0                      | 0    | 0     | 0 | 0                      | 0    | 0     | 0 | 0                        | 0    | 0     | 0 | 1                        | 1    | 1     | 0 | 3     | 49            |
| 2:20 PM                         | 0                      | 0    | 1     | 0 | 1                      | 0    | 0     | 0 | 0                        | 0    | 0     | 0 | 0                        | 1    | 2     | 0 | 5     | 50            |
| 2:25 PM                         | 0                      | 0    | 1     | 0 | 0                      | 0    | 0     | 0 | 0                        | 1    | 0     | 0 | 0                        | 1    | 0     | 0 | 3     | 43            |
| 2:30 PM                         | 0                      | 0    | 1     | 0 | 0                      | 0    | 0     | 0 | 0                        | 0    | 0     | 0 | 0                        | 0    | 0     | 0 | 1     | 43            |
| 2:35 PM                         | 0                      | 0    | 3     | 0 | 1                      | 0    | 0     | 0 | 0                        | 0    | 0     | 0 | 1                        | 0    | 0     | 0 | 5     | 46            |
| 2:40 PM                         | 0                      | 0    | 1     | 0 | 0                      | 0    | 0     | 0 | 0                        | 0    | 0     | 0 | 0                        | 1    | 1     | 0 | 3     | 42            |
| 2:45 PM                         | 0                      | 0    | 2     | 0 | 0                      | 1    | 0     | 0 | 0                        | 1    | 0     | 0 | 2                        | 2    | 2     | 0 | 10    | 48            |
| 2:50 PM                         | 0                      | 0    | 0     | 0 | 1                      | 0    | 0     | 0 | 0                        | 0    | 0     | 0 | 0                        | 2    | 1     | 0 | 4     | 48            |
| 2:55 PM                         | 0                      | 0    | 4     | 0 | 1                      | 0    | 0     | 0 | 0                        | 0    | 0     | 0 | 1                        | 1    | 1     | 0 | 8     | 51            |
| 3:00 PM                         | 0                      | 0    | 0     | 0 | 1                      | 0    | 0     | 0 | 0                        | 0    | 0     | 0 | 0                        | 3    | 0     | 0 | 4     | 52            |
| 3:05 PM                         | 0                      | 0    | 3     | 0 | 1                      | 0    | 0     | 0 | 0                        | 1    | 0     | 0 | 0                        | 0    | 0     | 0 | 5     | 53            |
| 3:10 PM                         | 0                      | 0    | 1     | 0 | 2                      | 0    | 0     | 0 | 0                        | 0    | 0     | 0 | 0                        | 0    | 0     | 0 | 3     | 54            |
| 3:15 PM                         | 0                      | 0    | 1     | 0 | 2                      | 0    | 0     | 0 | 0                        | 0    | 0     | 0 | 1                        | 0    | 0     | 0 | 4     | 55            |
| 3:20 PM                         | 0                      | 0    | 2     | 0 | 0                      | 0    | 0     | 0 | 0                        | 0    | 1     | 0 | 1                        | 2    | 0     | 0 | 6     | 56            |
| 3:25 PM                         | 0                      | 0    | 1     | 0 | 0                      | 0    | 0     | 0 | 0                        | 0    | 0     | 0 | 0                        | 0    | 1     | 0 | 2     | 55            |
| 3:30 PM                         | 0                      | 0    | 0     | 0 | 1                      | 0    | 0     | 0 | 0                        | 0    | 0     | 0 | 0                        | 0    | 0     | 0 | 1     | 55            |
| 3:35 PM                         | 0                      | 0    | 0     | 0 | 0                      | 0    | 0     | 0 | 0                        | 1    | 0     | 0 | 0                        | 0    | 1     | 0 | 2     | 52            |
| 3:40 PM                         | 0                      | 0    | 3     | 0 | 1                      | 0    | 0     | 0 | 0                        | 2    | 0     | 0 | 0                        | 1    | 1     | 0 | 8     | 57            |
| 3:45 PM                         | 0                      | 0    | 0     | 0 | 0                      | 0    | 0     | 0 | 0                        | 1    | 1     | 0 | 2                        | 1    | 3     | 0 | 8     | 55            |
| 3:50 PM                         | 0                      | 0    | 1     | 0 | 0                      | 0    | 0     | 0 | 0                        | 1    | 0     | 0 | 0                        | 1    | 0     | 0 | 3     | 54            |
| 3:55 PM                         | 0                      | 0    | 1     | 0 | 1                      | 0    | 0     | 0 | 0                        | 0    | 0     | 0 | 1                        | 1    | 0     | 0 | 4     | 50            |
| 4:00 PM                         | 0                      | 0    | 0     | 0 | 0                      | 0    | 1     | 0 | 0                        | 1    | 1     | 0 | 3                        | 0    | 0     | 0 | 6     | 52            |
| 4:05 PM                         | 0                      | 0    | 2     | 0 | 0                      | 0    | 0     | 0 | 0                        | 0    | 0     | 0 | 0                        | 2    | 0     | 0 | 4     | 51            |
| 4:10 PM                         | 0                      | 0    | 1     | 0 | 0                      | 0    | 0     | 0 | 0                        | 0    | 0     | 0 | 0                        | 0    | 0     | 0 | 1     | 49            |
| 4:15 PM                         | 0                      | 0    | 1     | 0 | 0                      | 0    | 0     | 0 | 0                        | 0    | 0     | 0 | 0                        | 1    | 2     | 0 | 4     | 49            |
| 4:20 PM                         | 0                      | 0    | 0     | 0 | 1                      | 0    | 0     | 0 | 0                        | 2    | 0     | 0 | 0                        | 0    | 0     | 0 | 3     | 46            |
| 4:25 PM                         | 0                      | 0    | 0     | 0 | 0                      | 0    | 0     | 0 | 0                        | 0    | 0     | 0 | 1                        | 0    | 1     | 0 | 2     | 46            |
| 4:30 PM                         | 0                      | 0    | 1     | 0 | 0                      | 0    | 0     | 0 | 0                        | 1    | 0     | 0 | 0                        | 0    | 1     | 0 | 3     | 48            |

**Attachment B**

| 5-Min Count Period Beginning At | Argyle Dr (Northbound) |      |       |   | Argyle Dr (Southbound) |      |       |   | Oak Knoll Dr (Eastbound) |      |       |   | Oak Knoll Dr (Westbound) |      |       |   | Total | Hourly Totals |
|---------------------------------|------------------------|------|-------|---|------------------------|------|-------|---|--------------------------|------|-------|---|--------------------------|------|-------|---|-------|---------------|
|                                 | Left                   | Thru | Right | U | Left                   | Thru | Right | U | Left                     | Thru | Right | U | Left                     | Thru | Right | U |       |               |
| 4:35 PM                         | 0                      | 0    | 0     | 0 | 0                      | 0    | 0     | 0 | 0                        | 1    | 0     | 0 | 1                        | 1    | 1     | 0 | 4     | 50            |
| 4:40 PM                         | 0                      | 0    | 0     | 0 | 2                      | 0    | 1     | 0 | 0                        | 0    | 0     | 0 | 1                        | 0    | 1     | 0 | 5     | 47            |
| 4:45 PM                         | 0                      | 0    | 0     | 0 | 1                      | 0    | 0     | 0 | 0                        | 0    | 0     | 0 | 0                        | 0    | 0     | 0 | 1     | 40            |
| 4:50 PM                         | 0                      | 0    | 1     | 0 | 0                      | 0    | 0     | 0 | 0                        | 1    | 0     | 0 | 1                        | 1    | 3     | 0 | 7     | 44            |
| 4:55 PM                         | 0                      | 0    | 0     | 0 | 0                      | 0    | 0     | 0 | 0                        | 0    | 0     | 0 | 0                        | 0    | 0     | 0 | 0     | 40            |
| 5:00 PM                         | 0                      | 0    | 0     | 0 | 0                      | 0    | 0     | 0 | 0                        | 0    | 0     | 0 | 0                        | 1    | 1     | 0 | 2     | 36            |
| 5:05 PM                         | 0                      | 0    | 0     | 0 | 0                      | 0    | 0     | 0 | 0                        | 0    | 0     | 0 | 0                        | 1    | 0     | 0 | 1     | 33            |
| 5:10 PM                         | 0                      | 0    | 0     | 0 | 2                      | 0    | 0     | 0 | 0                        | 0    | 0     | 0 | 0                        | 2    | 0     | 0 | 4     | 36            |
| 5:15 PM                         | 0                      | 0    | 1     | 0 | 0                      | 0    | 0     | 0 | 0                        | 0    | 0     | 0 | 0                        | 0    | 1     | 0 | 2     | 34            |
| 5:20 PM                         | 0                      | 0    | 0     | 0 | 1                      | 0    | 0     | 0 | 0                        | 0    | 0     | 0 | 0                        | 0    | 1     | 0 | 2     | 33            |
| 5:25 PM                         | 0                      | 0    | 1     | 0 | 1                      | 0    | 0     | 0 | 0                        | 0    | 0     | 0 | 1                        | 0    | 1     | 0 | 4     | 35            |
| 5:30 PM                         | 0                      | 0    | 3     | 0 | 0                      | 0    | 1     | 0 | 0                        | 0    | 0     | 0 | 1                        | 1    | 1     | 0 | 7     | 39            |
| 5:35 PM                         | 0                      | 0    | 0     | 0 | 1                      | 0    | 0     | 0 | 0                        | 2    | 0     | 0 | 1                        | 0    | 0     | 0 | 4     | 39            |
| 5:40 PM                         | 0                      | 0    | 1     | 0 | 1                      | 0    | 0     | 0 | 0                        | 0    | 0     | 0 | 0                        | 1    | 0     | 0 | 3     | 37            |
| 5:45 PM                         | 0                      | 0    | 0     | 0 | 0                      | 0    | 0     | 0 | 0                        | 0    | 0     | 0 | 0                        | 0    | 0     | 0 | 0     | 36            |
| 5:50 PM                         | 0                      | 0    | 1     | 0 | 1                      | 0    | 1     | 0 | 0                        | 1    | 0     | 0 | 1                        | 3    | 0     | 0 | 8     | 37            |
| 5:55 PM                         | 0                      | 0    | 0     | 0 | 0                      | 0    | 0     | 0 | 0                        | 0    | 0     | 0 | 1                        | 0    | 1     | 0 | 2     | 39            |
| 6:00 PM                         | 0                      | 0    | 3     | 0 | 0                      | 0    | 0     | 0 | 0                        | 1    | 0     | 0 | 1                        | 0    | 0     | 0 | 5     | 42            |
| 6:05 PM                         | 0                      | 0    | 1     | 0 | 0                      | 0    | 0     | 0 | 0                        | 1    | 0     | 0 | 0                        | 0    | 0     | 0 | 2     | 43            |
| 6:10 PM                         | 0                      | 0    | 2     | 0 | 2                      | 0    | 0     | 0 | 0                        | 1    | 0     | 0 | 1                        | 0    | 0     | 0 | 6     | 45            |
| 6:15 PM                         | 0                      | 0    | 0     | 0 | 2                      | 0    | 0     | 0 | 0                        | 0    | 0     | 0 | 0                        | 0    | 1     | 0 | 3     | 46            |
| 6:20 PM                         | 0                      | 0    | 0     | 0 | 0                      | 0    | 0     | 0 | 0                        | 0    | 0     | 0 | 0                        | 0    | 1     | 0 | 1     | 45            |
| 6:25 PM                         | 0                      | 0    | 0     | 0 | 0                      | 0    | 0     | 0 | 0                        | 0    | 0     | 0 | 1                        | 0    | 1     | 0 | 2     | 43            |
| 6:30 PM                         | 0                      | 0    | 0     | 0 | 0                      | 0    | 0     | 0 | 0                        | 0    | 0     | 0 | 0                        | 0    | 2     | 0 | 2     | 38            |
| 6:35 PM                         | 0                      | 0    | 0     | 0 | 0                      | 0    | 0     | 0 | 0                        | 1    | 0     | 0 | 0                        | 0    | 0     | 0 | 1     | 35            |
| 6:40 PM                         | 0                      | 0    | 0     | 0 | 0                      | 0    | 0     | 0 | 0                        | 0    | 0     | 0 | 1                        | 0    | 1     | 0 | 2     | 34            |
| 6:45 PM                         | 0                      | 0    | 1     | 0 | 0                      | 0    | 0     | 0 | 0                        | 0    | 0     | 0 | 0                        | 0    | 2     | 0 | 3     | 37            |
| 6:50 PM                         | 0                      | 0    | 0     | 0 | 0                      | 0    | 0     | 0 | 0                        | 0    | 0     | 0 | 1                        | 1    | 0     | 0 | 2     | 31            |
| 6:55 PM                         | 0                      | 0    | 0     | 0 | 2                      | 0    | 0     | 0 | 0                        | 0    | 0     | 0 | 1                        | 0    | 0     | 0 | 3     | 32            |
| 7:00 PM                         | 0                      | 0    | 0     | 0 | 0                      | 0    | 0     | 0 | 0                        | 1    | 0     | 0 | 0                        | 0    | 2     | 0 | 3     | 30            |
| 7:05 PM                         | 0                      | 0    | 0     | 0 | 1                      | 0    | 0     | 0 | 0                        | 1    | 0     | 0 | 1                        | 0    | 1     | 0 | 4     | 32            |
| 7:10 PM                         | 0                      | 0    | 0     | 0 | 1                      | 0    | 0     | 0 | 0                        | 1    | 0     | 0 | 0                        | 0    | 0     | 0 | 2     | 28            |
| 7:15 PM                         | 0                      | 0    | 1     | 0 | 0                      | 0    | 0     | 0 | 0                        | 0    | 0     | 0 | 1                        | 0    | 0     | 0 | 2     | 27            |
| 7:20 PM                         | 0                      | 0    | 0     | 0 | 3                      | 0    | 0     | 0 | 0                        | 1    | 0     | 0 | 0                        | 2    | 2     | 0 | 8     | 34            |
| 7:25 PM                         | 0                      | 0    | 0     | 0 | 0                      | 0    | 0     | 0 | 0                        | 0    | 0     | 0 | 0                        | 1    | 1     | 0 | 2     | 34            |
| 7:30 PM                         | 0                      | 0    | 1     | 0 | 0                      | 0    | 0     | 0 | 0                        | 0    | 0     | 0 | 0                        | 0    | 1     | 0 | 2     | 34            |
| 7:35 PM                         | 0                      | 0    | 0     | 0 | 0                      | 0    | 0     | 0 | 0                        | 1    | 0     | 0 | 1                        | 0    | 0     | 0 | 2     | 35            |
| 7:40 PM                         | 0                      | 0    | 0     | 0 | 0                      | 0    | 0     | 0 | 0                        | 1    | 0     | 0 | 2                        | 0    | 0     | 0 | 3     | 36            |
| 7:45 PM                         | 0                      | 0    | 1     | 0 | 0                      | 0    | 0     | 0 | 0                        | 0    | 0     | 0 | 2                        | 1    | 1     | 0 | 5     | 38            |
| 7:50 PM                         | 0                      | 0    | 1     | 0 | 0                      | 0    | 0     | 0 | 0                        | 0    | 0     | 0 | 1                        | 0    | 0     | 0 | 2     | 38            |
| 7:55 PM                         | 0                      | 0    | 1     | 0 | 0                      | 0    | 0     | 0 | 0                        | 0    | 0     | 0 | 0                        | 0    | 0     | 0 | 1     | 36            |
| 8:00 PM                         | 0                      | 0    | 0     | 0 | 0                      | 0    | 0     | 0 | 0                        | 0    | 0     | 0 | 0                        | 0    | 0     | 0 | 0     | 33            |
| 8:05 PM                         | 0                      | 0    | 0     | 0 | 0                      | 0    | 0     | 0 | 0                        | 1    | 0     | 0 | 0                        | 0    | 2     | 0 | 3     | 32            |
| 8:10 PM                         | 0                      | 0    | 0     | 0 | 0                      | 0    | 0     | 0 | 0                        | 0    | 0     | 0 | 1                        | 1    | 1     | 0 | 3     | 33            |
| 8:15 PM                         | 0                      | 0    | 0     | 0 | 0                      | 0    | 0     | 0 | 0                        | 0    | 0     | 0 | 0                        | 0    | 1     | 0 | 1     | 32            |
| 8:20 PM                         | 0                      | 0    | 0     | 0 | 1                      | 0    | 0     | 0 | 0                        | 0    | 0     | 0 | 0                        | 0    | 0     | 0 | 1     | 25            |
| 8:25 PM                         | 0                      | 0    | 0     | 0 | 0                      | 0    | 0     | 0 | 0                        | 0    | 0     | 0 | 2                        | 0    | 0     | 0 | 2     | 25            |
| 8:30 PM                         | 0                      | 0    | 0     | 0 | 0                      | 0    | 0     | 0 | 0                        | 0    | 0     | 0 | 0                        | 0    | 0     | 0 | 0     | 23            |
| 8:35 PM                         | 0                      | 0    | 1     | 0 | 0                      | 0    | 0     | 0 | 0                        | 0    | 0     | 0 | 1                        | 0    | 0     | 0 | 2     | 23            |
| 8:40 PM                         | 0                      | 0    | 0     | 0 | 0                      | 0    | 0     | 0 | 0                        | 0    | 0     | 0 | 0                        | 0    | 0     | 0 | 0     | 20            |
| 8:45 PM                         | 0                      | 0    | 0     | 0 | 0                      | 0    | 0     | 0 | 0                        | 0    | 0     | 0 | 1                        | 0    | 0     | 0 | 1     | 16            |
| 8:50 PM                         | 0                      | 0    | 0     | 0 | 0                      | 0    | 0     | 0 | 0                        | 0    | 0     | 0 | 0                        | 0    | 0     | 0 | 0     | 14            |
| 8:55 PM                         | 0                      | 0    | 0     | 0 | 0                      | 0    | 0     | 0 | 0                        | 0    | 0     | 0 | 1                        | 0    | 2     | 0 | 3     | 16            |
| 9:00 PM                         | 0                      | 0    | 0     | 0 | 1                      | 0    | 0     | 0 | 0                        | 0    | 0     | 0 | 0                        | 1    | 0     | 0 | 2     | 18            |
| 9:05 PM                         | 0                      | 0    | 1     | 0 | 0                      | 0    | 0     | 0 | 0                        | 0    | 0     | 0 | 0                        | 1    | 0     | 0 | 2     | 17            |
| 9:10 PM                         | 0                      | 0    | 0     | 0 | 1                      | 0    | 0     | 0 | 0                        | 0    | 0     | 0 | 0                        | 0    | 0     | 0 | 1     | 15            |
| 9:15 PM                         | 0                      | 0    | 0     | 0 | 0                      | 0    | 0     | 0 | 0                        | 0    | 0     | 0 | 0                        | 0    | 0     | 0 | 0     | 14            |
| 9:20 PM                         | 0                      | 0    | 0     | 0 | 0                      | 0    | 0     | 0 | 0                        | 1    | 0     | 0 | 0                        | 0    | 0     | 0 | 1     | 14            |
| 9:25 PM                         | 0                      | 0    | 0     | 0 | 1                      | 0    | 0     | 0 | 0                        | 0    | 0     | 0 | 1                        | 0    | 0     | 0 | 2     | 14            |
| 9:30 PM                         | 0                      | 0    | 1     | 0 | 0                      | 0    | 0     | 0 | 0                        | 0    | 0     | 0 | 0                        | 0    | 1     | 0 | 2     | 16            |
| 9:35 PM                         | 0                      | 0    | 0     | 0 | 1                      | 0    | 0     | 0 | 0                        | 0    | 0     | 0 | 0                        | 1    | 0     | 0 | 2     | 16            |
| 9:40 PM                         | 0                      | 0    | 0     | 0 | 0                      | 0    | 0     | 0 | 0                        | 0    | 0     | 0 | 0                        | 0    | 0     | 0 | 0     | 16            |
| 9:45 PM                         | 0                      | 0    | 0     | 0 | 0                      | 0    | 0     | 0 | 0                        | 0    | 0     | 0 | 0                        | 0    | 0     | 0 | 0     | 15            |
| 9:50 PM                         | 0                      | 0    | 0     | 0 | 0                      | 0    | 0     | 0 | 0                        | 0    | 0     | 0 | 0                        | 0    | 0     | 0 | 0     | 15            |
| 9:55 PM                         | 0                      | 0    | 0     | 0 | 0                      | 0    | 0     | 0 | 0                        | 0    | 0     | 0 | 0                        | 1    | 1     | 0 | 2     | 14            |
| Peak 15-Min Flowrates           | Northbound             |      |       |   | Southbound             |      |       |   | Eastbound                |      |       |   | Westbound                |      |       |   | Total |               |
|                                 | Left                   | Thru | Right | U | Left                   | Thru | Right | U | Left                     | Thru | Right | U | Left                     | Thru | Right | U |       |               |
| All Vehicles                    | 0                      | 0    | 24    | 0 | 4                      | 0    | 0     | 0 | 0                        | 20   | 0     | 0 | 4                        | 12   | 16    | 0 | 80    |               |
| Heavy Trucks                    | 0                      | 0    | 0     | 0 | 0                      | 0    | 0     | 0 | 0                        | 0    | 0     | 0 | 0                        | 0    | 0     | 0 | 0     |               |
| Buses                           |                        |      |       |   |                        |      |       |   |                          |      |       |   |                          |      |       |   |       |               |
| Pedestrians                     |                        | 0    |       |   |                        | 0    |       |   |                          | 4    |       |   |                          | 12   |       |   | 16    |               |
| Bicycles                        | 0                      | 0    | 0     |   | 0                      | 0    | 0     |   | 0                        | 0    | 0     |   | 0                        | 0    | 0     |   | 0     |               |
| Scoters                         |                        |      |       |   |                        |      |       |   |                          |      |       |   |                          |      |       |   |       |               |
| <i>Comments:</i>                |                        |      |       |   |                        |      |       |   |                          |      |       |   |                          |      |       |   |       |               |

LOCATION: Weatherby Rd -- Huntley Dr  
 CITY/STATE: Rossmoor, CA

QC JOB #: 16966424  
 DATE: Wed, Apr 9 2025

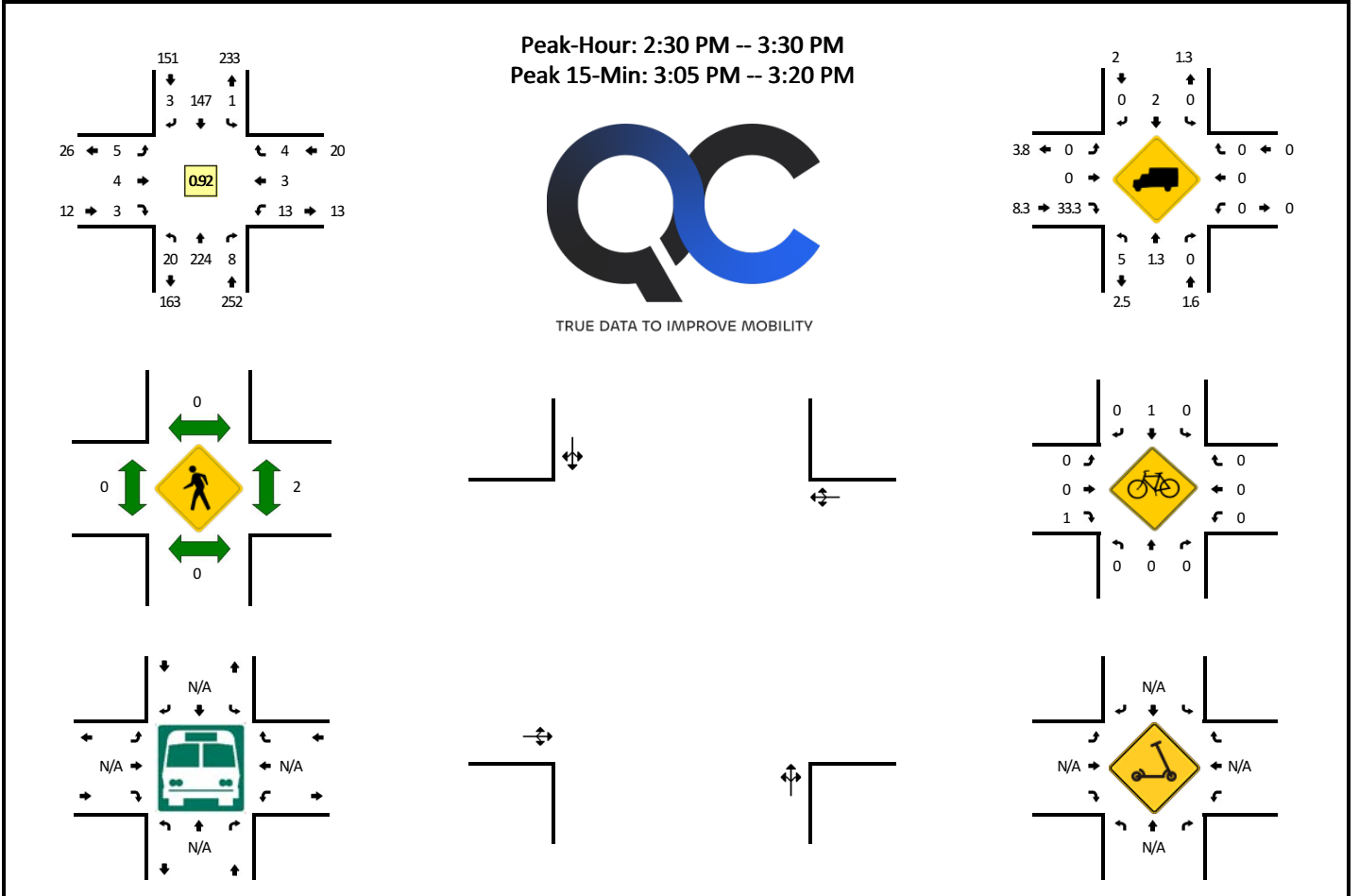

| 5-Min Count Period Beginning At | Weatherby Rd (Northbound) |      |       |   | Weatherby Rd (Southbound) |      |       |   | Huntley Dr (Eastbound) |      |       |   | Huntley Dr (Westbound) |      |       |   | Total | Hourly Totals |
|---------------------------------|---------------------------|------|-------|---|---------------------------|------|-------|---|------------------------|------|-------|---|------------------------|------|-------|---|-------|---------------|
|                                 | Left                      | Thru | Right | U | Left                      | Thru | Right | U | Left                   | Thru | Right | U | Left                   | Thru | Right | U |       |               |
| 6:00 AM                         | 0                         | 0    | 0     | 0 | 0                         | 0    | 0     | 0 | 0                      | 0    | 0     | 0 | 0                      | 0    | 0     | 0 | 0     |               |
| 6:05 AM                         | 0                         | 1    | 0     | 0 | 1                         | 0    | 0     | 0 | 0                      | 0    | 0     | 0 | 0                      | 0    | 1     | 0 | 3     |               |
| 6:10 AM                         | 1                         | 0    | 0     | 0 | 0                         | 2    | 0     | 0 | 0                      | 0    | 0     | 0 | 0                      | 0    | 0     | 0 | 3     |               |
| 6:15 AM                         | 0                         | 0    | 0     | 0 | 0                         | 0    | 0     | 0 | 0                      | 0    | 0     | 0 | 0                      | 0    | 0     | 0 | 0     |               |
| 6:20 AM                         | 0                         | 0    | 0     | 0 | 0                         | 0    | 0     | 0 | 0                      | 0    | 0     | 0 | 0                      | 0    | 0     | 0 | 0     |               |
| 6:25 AM                         | 0                         | 0    | 0     | 0 | 0                         | 0    | 0     | 0 | 1                      | 0    | 0     | 0 | 0                      | 0    | 0     | 0 | 1     |               |
| 6:30 AM                         | 0                         | 1    | 0     | 0 | 0                         | 1    | 0     | 0 | 0                      | 0    | 0     | 0 | 0                      | 0    | 0     | 0 | 2     |               |
| 6:35 AM                         | 0                         | 1    | 0     | 0 | 0                         | 0    | 0     | 0 | 0                      | 0    | 1     | 0 | 0                      | 0    | 0     | 0 | 2     |               |
| 6:40 AM                         | 0                         | 0    | 0     | 0 | 0                         | 1    | 0     | 0 | 0                      | 0    | 1     | 0 | 1                      | 0    | 0     | 0 | 3     |               |
| 6:45 AM                         | 0                         | 1    | 1     | 0 | 0                         | 0    | 0     | 0 | 0                      | 0    | 0     | 0 | 0                      | 0    | 0     | 0 | 2     |               |
| 6:50 AM                         | 0                         | 1    | 0     | 0 | 0                         | 0    | 0     | 0 | 1                      | 0    | 0     | 0 | 0                      | 0    | 0     | 0 | 2     |               |
| 6:55 AM                         | 0                         | 0    | 0     | 0 | 0                         | 0    | 0     | 0 | 0                      | 0    | 0     | 0 | 0                      | 0    | 0     | 0 | 0     |               |
| 7:00 AM                         | 0                         | 3    | 0     | 0 | 0                         | 0    | 0     | 0 | 0                      | 0    | 0     | 0 | 0                      | 0    | 0     | 0 | 3     |               |
| 7:05 AM                         | 0                         | 0    | 1     | 0 | 0                         | 0    | 0     | 0 | 0                      | 0    | 0     | 0 | 1                      | 0    | 0     | 0 | 2     |               |
| 7:10 AM                         | 0                         | 0    | 0     | 0 | 0                         | 3    | 0     | 0 | 0                      | 0    | 0     | 0 | 1                      | 0    | 0     | 0 | 4     |               |
| 7:15 AM                         | 0                         | 1    | 0     | 0 | 0                         | 0    | 0     | 0 | 0                      | 0    | 0     | 0 | 0                      | 0    | 0     | 0 | 1     |               |
| 7:20 AM                         | 0                         | 1    | 1     | 0 | 0                         | 1    | 0     | 0 | 0                      | 0    | 1     | 0 | 0                      | 0    | 0     | 0 | 4     |               |
| 7:25 AM                         | 2                         | 1    | 0     | 0 | 0                         | 0    | 0     | 0 | 0                      | 0    | 0     | 0 | 0                      | 0    | 0     | 0 | 3     |               |
| 7:30 AM                         | 1                         | 1    | 0     | 0 | 0                         | 1    | 1     | 0 | 0                      | 0    | 1     | 0 | 0                      | 1    | 0     | 0 | 6     |               |
| 7:35 AM                         | 0                         | 0    | 0     | 0 | 0                         | 0    | 0     | 0 | 0                      | 0    | 1     | 0 | 0                      | 0    | 0     | 0 | 1     |               |
| 7:40 AM                         | 5                         | 1    | 0     | 0 | 0                         | 1    | 1     | 0 | 0                      | 0    | 0     | 0 | 0                      | 1    | 0     | 0 | 9     |               |
| 7:45 AM                         | 3                         | 1    | 0     | 0 | 0                         | 0    | 1     | 0 | 1                      | 0    | 3     | 0 | 0                      | 1    | 0     | 0 | 10    |               |
| 7:50 AM                         | 0                         | 4    | 1     | 0 | 0                         | 2    | 0     | 0 | 1                      | 0    | 1     | 0 | 0                      | 0    | 0     | 0 | 9     |               |
| 7:55 AM                         | 1                         | 2    | 0     | 0 | 0                         | 2    | 0     | 0 | 1                      | 1    | 4     | 0 | 0                      | 0    | 0     | 0 | 11    |               |
| 8:00 AM                         | 0                         | 1    | 1     | 0 | 0                         | 0    | 0     | 0 | 0                      | 0    | 0     | 0 | 0                      | 0    | 0     | 0 | 2     |               |
| 8:05 AM                         | 0                         | 2    | 2     | 0 | 0                         | 1    | 0     | 0 | 1                      | 0    | 0     | 0 | 0                      | 0    | 0     | 0 | 6     |               |
| 8:10 AM                         | 0                         | 3    | 0     | 0 | 0                         | 1    | 1     | 0 | 0                      | 0    | 0     | 0 | 1                      | 0    | 0     | 0 | 6     |               |
| 8:15 AM                         | 1                         | 2    | 1     | 0 | 0                         | 3    | 1     | 0 | 0                      | 0    | 1     | 0 | 0                      | 1    | 0     | 0 | 10    |               |
| 8:20 AM                         | 0                         | 2    | 0     | 0 | 0                         | 1    | 0     | 0 | 0                      | 0    | 0     | 0 | 0                      | 0    | 1     | 0 | 4     |               |
| 8:25 AM                         | 0                         | 0    | 0     | 0 | 0                         | 4    | 0     | 0 | 1                      | 0    | 0     | 0 | 0                      | 0    | 0     | 0 | 5     |               |
| 8:30 AM                         | 0                         | 4    | 0     | 0 | 0                         | 0    | 0     | 0 | 1                      | 0    | 0     | 0 | 1                      | 0    | 0     | 0 | 6     |               |
| 8:35 AM                         | 2                         | 3    | 0     | 0 | 0                         | 6    | 0     | 0 | 0                      | 0    | 0     | 0 | 2                      | 0    | 0     | 0 | 13    |               |
| 8:40 AM                         | 0                         | 0    | 1     | 0 | 0                         | 0    | 0     | 0 | 1                      | 0    | 0     | 0 | 0                      | 0    | 0     | 0 | 2     |               |
| 8:45 AM                         | 0                         | 4    | 0     | 0 | 0                         | 3    | 0     | 0 | 0                      | 0    | 1     | 0 | 1                      | 0    | 1     | 0 | 10    |               |
| 8:50 AM                         | 1                         | 1    | 0     | 0 | 0                         | 1    | 0     | 0 | 0                      | 0    | 0     | 0 | 2                      | 0    | 0     | 0 | 5     |               |
| 8:55 AM                         | 0                         | 2    | 0     | 0 | 1                         | 3    | 0     | 0 | 0                      | 0    | 0     | 0 | 0                      | 1    | 0     | 0 | 7     |               |
| 9:00 AM                         | 0                         | 1    | 0     | 0 | 0                         | 2    | 1     | 0 | 0                      | 0    | 0     | 0 | 0                      | 0    | 0     | 0 | 4     |               |
| 9:05 AM                         | 2                         | 2    | 0     | 0 | 0                         | 0    | 0     | 0 | 0                      | 0    | 1     | 0 | 0                      | 0    | 0     | 0 | 5     |               |

Attachment B

| 5-Min Count Period Beginning At | Weatherby Rd (Northbound) |      |       |   | Weatherby Rd (Southbound) |      |       |   | Huntley Dr (Eastbound) |      |       |   | Huntley Dr (Westbound) |      |       |   | Total | Hourly Totals |     |
|---------------------------------|---------------------------|------|-------|---|---------------------------|------|-------|---|------------------------|------|-------|---|------------------------|------|-------|---|-------|---------------|-----|
|                                 | Left                      | Thru | Right | U | Left                      | Thru | Right | U | Left                   | Thru | Right | U | Left                   | Thru | Right | U |       |               |     |
| 9:10 AM                         | 2                         | 2    | 0     | 0 | 0                         | 2    | 0     | 0 | 0                      | 0    | 0     | 1 | 0                      | 0    | 0     | 1 | 0     | 8             | 79  |
| 9:15 AM                         | 0                         | 1    | 0     | 0 | 0                         | 0    | 0     | 0 | 0                      | 0    | 0     | 0 | 0                      | 0    | 0     | 0 | 0     | 1             | 70  |
| 9:20 AM                         | 2                         | 0    | 0     | 0 | 0                         | 0    | 0     | 0 | 0                      | 1    | 0     | 0 | 0                      | 0    | 0     | 0 | 0     | 3             | 69  |
| 9:25 AM                         | 0                         | 0    | 0     | 0 | 0                         | 1    | 0     | 0 | 0                      | 0    | 0     | 0 | 0                      | 0    | 0     | 0 | 0     | 1             | 65  |
| 9:30 AM                         | 1                         | 2    | 0     | 0 | 0                         | 2    | 0     | 0 | 0                      | 0    | 0     | 1 | 0                      | 0    | 0     | 0 | 0     | 6             | 65  |
| 9:35 AM                         | 0                         | 1    | 3     | 0 | 0                         | 2    | 0     | 0 | 0                      | 0    | 1     | 0 | 0                      | 1    | 0     | 0 | 0     | 8             | 60  |
| 9:40 AM                         | 1                         | 0    | 0     | 0 | 0                         | 0    | 0     | 0 | 0                      | 0    | 0     | 1 | 0                      | 0    | 0     | 0 | 0     | 2             | 60  |
| 9:45 AM                         | 0                         | 1    | 0     | 0 | 0                         | 1    | 0     | 0 | 0                      | 1    | 0     | 0 | 0                      | 0    | 0     | 0 | 0     | 3             | 53  |
| 9:50 AM                         | 1                         | 1    | 2     | 0 | 0                         | 2    | 0     | 0 | 0                      | 0    | 0     | 0 | 0                      | 0    | 0     | 0 | 0     | 6             | 54  |
| 9:55 AM                         | 1                         | 1    | 0     | 0 | 0                         | 0    | 0     | 0 | 0                      | 0    | 0     | 0 | 0                      | 0    | 1     | 0 | 0     | 3             | 50  |
| 10:00 AM                        | 0                         | 1    | 2     | 0 | 1                         | 1    | 0     | 0 | 0                      | 0    | 0     | 1 | 0                      | 0    | 0     | 1 | 0     | 7             | 53  |
| 10:05 AM                        | 0                         | 1    | 0     | 0 | 0                         | 3    | 0     | 0 | 0                      | 0    | 0     | 1 | 0                      | 1    | 1     | 0 | 0     | 7             | 55  |
| 10:10 AM                        | 1                         | 0    | 0     | 0 | 0                         | 1    | 0     | 0 | 0                      | 0    | 1     | 0 | 0                      | 0    | 0     | 0 | 0     | 3             | 50  |
| 10:15 AM                        | 0                         | 1    | 0     | 0 | 0                         | 0    | 1     | 0 | 0                      | 0    | 0     | 0 | 0                      | 0    | 0     | 0 | 0     | 2             | 51  |
| 10:20 AM                        | 0                         | 2    | 2     | 0 | 0                         | 4    | 0     | 0 | 0                      | 0    | 0     | 0 | 0                      | 0    | 0     | 0 | 0     | 8             | 56  |
| 10:25 AM                        | 0                         | 2    | 2     | 0 | 2                         | 1    | 0     | 0 | 0                      | 0    | 0     | 0 | 0                      | 0    | 0     | 0 | 0     | 7             | 62  |
| 10:30 AM                        | 1                         | 0    | 0     | 0 | 0                         | 1    | 0     | 0 | 0                      | 0    | 0     | 0 | 0                      | 1    | 0     | 0 | 0     | 3             | 59  |
| 10:35 AM                        | 0                         | 3    | 0     | 0 | 2                         | 0    | 0     | 0 | 0                      | 0    | 0     | 0 | 0                      | 0    | 0     | 0 | 0     | 5             | 56  |
| 10:40 AM                        | 1                         | 0    | 2     | 0 | 0                         | 0    | 1     | 0 | 0                      | 2    | 0     | 0 | 0                      | 0    | 0     | 0 | 0     | 6             | 60  |
| 10:45 AM                        | 0                         | 1    | 0     | 0 | 0                         | 2    | 0     | 0 | 0                      | 0    | 0     | 0 | 0                      | 1    | 0     | 0 | 0     | 4             | 61  |
| 10:50 AM                        | 0                         | 0    | 0     | 0 | 0                         | 2    | 0     | 0 | 0                      | 0    | 0     | 1 | 0                      | 0    | 0     | 1 | 0     | 4             | 59  |
| 10:55 AM                        | 0                         | 0    | 0     | 0 | 0                         | 3    | 0     | 0 | 0                      | 0    | 0     | 0 | 0                      | 0    | 0     | 0 | 0     | 3             | 59  |
| 11:00 AM                        | 0                         | 2    | 0     | 0 | 0                         | 2    | 2     | 0 | 0                      | 0    | 1     | 2 | 0                      | 1    | 0     | 0 | 0     | 10            | 62  |
| 11:05 AM                        | 0                         | 2    | 0     | 0 | 0                         | 1    | 0     | 0 | 0                      | 0    | 0     | 1 | 0                      | 0    | 0     | 0 | 0     | 4             | 59  |
| 11:10 AM                        | 1                         | 1    | 0     | 0 | 0                         | 1    | 0     | 0 | 0                      | 0    | 0     | 2 | 0                      | 1    | 0     | 0 | 0     | 6             | 62  |
| 11:15 AM                        | 0                         | 1    | 0     | 0 | 0                         | 1    | 0     | 0 | 0                      | 0    | 0     | 0 | 0                      | 2    | 0     | 0 | 0     | 4             | 64  |
| 11:20 AM                        | 0                         | 2    | 0     | 0 | 0                         | 0    | 0     | 0 | 0                      | 1    | 0     | 1 | 0                      | 0    | 0     | 0 | 0     | 4             | 60  |
| 11:25 AM                        | 1                         | 1    | 0     | 0 | 0                         | 2    | 0     | 0 | 0                      | 0    | 0     | 0 | 0                      | 0    | 0     | 0 | 0     | 4             | 57  |
| 11:30 AM                        | 1                         | 3    | 1     | 0 | 0                         | 3    | 0     | 0 | 0                      | 1    | 0     | 1 | 0                      | 1    | 0     | 0 | 0     | 11            | 65  |
| 11:35 AM                        | 0                         | 1    | 0     | 0 | 0                         | 2    | 1     | 0 | 0                      | 0    | 0     | 1 | 0                      | 0    | 0     | 1 | 0     | 6             | 66  |
| 11:40 AM                        | 0                         | 1    | 0     | 0 | 0                         | 1    | 0     | 0 | 0                      | 0    | 1     | 0 | 0                      | 1    | 0     | 0 | 0     | 4             | 64  |
| 11:45 AM                        | 1                         | 0    | 2     | 0 | 0                         | 1    | 0     | 0 | 0                      | 1    | 0     | 0 | 0                      | 0    | 0     | 0 | 0     | 5             | 65  |
| 11:50 AM                        | 1                         | 0    | 1     | 0 | 0                         | 0    | 0     | 0 | 0                      | 0    | 0     | 0 | 0                      | 1    | 0     | 1 | 0     | 4             | 65  |
| 11:55 AM                        | 1                         | 1    | 0     | 0 | 0                         | 2    | 0     | 0 | 0                      | 2    | 1     | 0 | 0                      | 1    | 0     | 0 | 0     | 8             | 70  |
| 12:00 PM                        | 0                         | 0    | 0     | 0 | 0                         | 1    | 0     | 0 | 0                      | 0    | 0     | 3 | 0                      | 0    | 0     | 0 | 0     | 4             | 64  |
| 12:05 PM                        | 0                         | 1    | 0     | 0 | 0                         | 2    | 0     | 0 | 0                      | 0    | 0     | 1 | 0                      | 1    | 0     | 0 | 0     | 5             | 65  |
| 12:10 PM                        | 0                         | 0    | 0     | 0 | 0                         | 1    | 0     | 0 | 0                      | 0    | 0     | 0 | 0                      | 0    | 0     | 0 | 0     | 1             | 60  |
| 12:15 PM                        | 0                         | 2    | 1     | 0 | 0                         | 3    | 0     | 0 | 0                      | 0    | 0     | 2 | 0                      | 0    | 0     | 0 | 0     | 8             | 64  |
| 12:20 PM                        | 0                         | 0    | 0     | 0 | 0                         | 1    | 1     | 0 | 0                      | 0    | 0     | 1 | 0                      | 0    | 0     | 0 | 0     | 3             | 63  |
| 12:25 PM                        | 0                         | 0    | 1     | 0 | 0                         | 1    | 0     | 0 | 0                      | 0    | 0     | 0 | 0                      | 1    | 1     | 0 | 0     | 4             | 63  |
| 12:30 PM                        | 0                         | 0    | 0     | 0 | 0                         | 1    | 0     | 0 | 0                      | 1    | 0     | 1 | 0                      | 2    | 0     | 0 | 0     | 5             | 57  |
| 12:35 PM                        | 1                         | 0    | 1     | 0 | 0                         | 0    | 0     | 0 | 0                      | 0    | 0     | 0 | 0                      | 1    | 0     | 0 | 0     | 3             | 54  |
| 12:40 PM                        | 1                         | 1    | 0     | 0 | 0                         | 2    | 0     | 0 | 0                      | 0    | 0     | 0 | 0                      | 0    | 0     | 0 | 0     | 4             | 54  |
| 12:45 PM                        | 4                         | 3    | 0     | 0 | 0                         | 1    | 0     | 0 | 0                      | 0    | 0     | 0 | 0                      | 1    | 0     | 0 | 0     | 9             | 58  |
| 12:50 PM                        | 1                         | 2    | 1     | 0 | 0                         | 2    | 0     | 0 | 0                      | 1    | 0     | 1 | 0                      | 0    | 0     | 0 | 0     | 8             | 62  |
| 12:55 PM                        | 1                         | 0    | 0     | 0 | 0                         | 5    | 0     | 0 | 0                      | 1    | 3     | 3 | 0                      | 0    | 0     | 0 | 0     | 13            | 67  |
| 1:00 PM                         | 1                         | 2    | 3     | 0 | 0                         | 3    | 1     | 0 | 0                      | 1    | 0     | 1 | 0                      | 0    | 0     | 0 | 0     | 12            | 75  |
| 1:05 PM                         | 0                         | 3    | 0     | 0 | 0                         | 3    | 0     | 0 | 0                      | 0    | 0     | 0 | 0                      | 0    | 0     | 0 | 0     | 6             | 76  |
| 1:10 PM                         | 0                         | 1    | 0     | 0 | 0                         | 2    | 0     | 0 | 0                      | 0    | 0     | 0 | 0                      | 0    | 0     | 0 | 0     | 3             | 78  |
| 1:15 PM                         | 0                         | 0    | 1     | 0 | 0                         | 3    | 1     | 0 | 0                      | 0    | 1     | 1 | 0                      | 0    | 0     | 0 | 0     | 7             | 77  |
| 1:20 PM                         | 0                         | 1    | 1     | 0 | 0                         | 3    | 0     | 0 | 0                      | 0    | 0     | 0 | 0                      | 0    | 0     | 1 | 0     | 6             | 80  |
| 1:25 PM                         | 0                         | 0    | 1     | 0 | 0                         | 3    | 1     | 0 | 0                      | 0    | 0     | 1 | 0                      | 0    | 0     | 0 | 0     | 6             | 82  |
| 1:30 PM                         | 0                         | 1    | 0     | 0 | 0                         | 2    | 0     | 0 | 0                      | 1    | 1     | 0 | 0                      | 0    | 0     | 0 | 0     | 5             | 82  |
| 1:35 PM                         | 0                         | 1    | 1     | 0 | 1                         | 4    | 0     | 0 | 0                      | 0    | 0     | 0 | 0                      | 0    | 0     | 0 | 0     | 7             | 86  |
| 1:40 PM                         | 1                         | 5    | 0     | 0 | 0                         | 3    | 0     | 0 | 0                      | 1    | 0     | 0 | 0                      | 0    | 1     | 0 | 0     | 11            | 93  |
| 1:45 PM                         | 1                         | 13   | 0     | 0 | 0                         | 1    | 0     | 0 | 0                      | 0    | 0     | 0 | 0                      | 0    | 0     | 0 | 0     | 15            | 99  |
| 1:50 PM                         | 1                         | 20   | 0     | 0 | 0                         | 4    | 1     | 0 | 0                      | 0    | 0     | 0 | 0                      | 0    | 0     | 0 | 0     | 26            | 117 |
| 1:55 PM                         | 2                         | 13   | 0     | 0 | 0                         | 4    | 0     | 0 | 0                      | 0    | 0     | 0 | 0                      | 0    | 0     | 0 | 0     | 19            | 123 |
| 2:00 PM                         | 2                         | 9    | 0     | 0 | 0                         | 0    | 1     | 0 | 0                      | 0    | 0     | 0 | 0                      | 0    | 1     | 0 | 0     | 13            | 124 |
| 2:05 PM                         | 0                         | 16   | 0     | 0 | 0                         | 1    | 0     | 0 | 0                      | 0    | 0     | 0 | 0                      | 0    | 0     | 0 | 0     | 17            | 135 |
| 2:10 PM                         | 2                         | 21   | 1     | 0 | 0                         | 0    | 0     | 0 | 0                      | 0    | 0     | 2 | 0                      | 0    | 0     | 0 | 0     | 26            | 158 |
| 2:15 PM                         | 3                         | 25   | 0     | 0 | 0                         | 2    | 0     | 0 | 0                      | 0    | 0     | 0 | 0                      | 0    | 1     | 0 | 0     | 31            | 182 |
| 2:20 PM                         | 0                         | 13   | 0     | 0 | 0                         | 8    | 1     | 0 | 0                      | 0    | 0     | 0 | 0                      | 0    | 0     | 0 | 0     | 22            | 198 |
| 2:25 PM                         | 2                         | 13   | 1     | 0 | 0                         | 16   | 0     | 0 | 0                      | 0    | 1     | 0 | 0                      | 0    | 0     | 0 | 0     | 33            | 225 |
| 2:30 PM                         | 3                         | 10   | 1     | 0 | 0                         | 23   | 0     | 0 | 0                      | 0    | 0     | 0 | 0                      | 0    | 0     | 0 | 0     | 37            | 257 |
| 2:35 PM                         | 0                         | 13   | 0     | 0 | 0                         | 12   | 0     | 0 | 0                      | 0    | 0     | 0 | 0                      | 0    | 0     | 0 | 0     | 25            | 275 |
| 2:40 PM                         | 0                         | 16   | 0     | 0 | 0                         | 20   | 0     | 0 | 0                      | 0    | 0     | 0 | 0                      | 0    | 0     | 0 | 0     | 36            | 300 |
| 2:45 PM                         | 2                         | 25   | 2     | 0 | 0                         | 7    | 0     | 0 | 0                      | 1    | 0     | 0 | 0                      | 2    | 0     | 0 | 0     | 39            | 324 |
| 2:50 PM                         | 0                         | 8    | 0     | 0 | 0                         | 14   | 1     | 0 | 0                      | 0    | 0     | 0 | 0                      | 4    | 3     | 2 | 0     | 32            | 330 |
| 2:55 PM                         | 3                         | 17   | 0     | 0 | 1                         | 17   | 0     | 0 | 0                      | 2    | 0     | 0 | 0                      | 2    | 0     | 1 | 0     | 43            | 354 |
| 3:00 PM                         | 2                         | 18   | 0     | 0 | 0                         | 11   | 1     | 0 | 0                      | 1    | 0     | 0 | 0                      | 1    | 0     | 1 | 0     | 35            | 376 |
| 3:05 PM                         | 3                         | 23   | 0     | 0 | 0                         | 5    | 0     | 0 | 0                      | 0    | 0     | 1 | 0                      | 1    | 0     | 0 | 0     | 33            | 392 |
| 3:10 PM                         | 2                         | 25   | 3     | 0 | 0                         | 8    | 1     | 0 | 0                      | 1    | 2     | 1 | 0                      | 1    | 0     | 0 | 0     | 44            | 410 |
| 3:15 PM                         | 3                         | 23   | 0     | 0 | 0                         | 15   | 0     | 0 | 0                      | 0    | 0     | 0 | 0                      | 0    | 0     | 0 | 0     | 41            | 420 |
| 3:20 PM                         | 2                         | 23   | 1     | 0 | 0                         | 2    | 0     | 0 | 0                      | 0    | 1     | 0 | 0                      | 0    | 0     | 0 | 0     | 29            | 427 |
| 3:25 PM                         | 0                         | 23   | 1     | 0 | 0                         | 13   | 0     | 0 | 0                      | 0    | 1     | 1 | 0                      | 2    | 0     | 0 | 0     | 41            | 435 |
| 3:30 PM                         | 2                         | 19   | 0     | 0 | 0                         | 11   | 0     | 0 | 0                      | 0    | 0     | 1 | 0                      | 1    | 0     | 0 | 0     | 34            | 432 |
| 3:35 PM                         | 0                         | 10   | 0     | 0 | 0                         | 13   | 0     | 0 | 0                      | 1    | 0     | 1 | 0                      | 1    | 0     | 0 | 0     | 26            | 433 |
| 3:40 PM                         | 2                         | 17   | 0     | 0 | 0                         | 10   | 0     | 0 | 0                      | 0    | 1     | 1 | 0                      | 0    | 0     | 0 | 0     | 31            | 428 |
| 3:45 PM                         | 2                         | 14   | 0     | 0 | 0                         | 9    | 0     | 0 | 0                      | 0    | 0     | 1 | 0                      | 0    | 0     | 0 | 0     | 26            | 415 |
| 3:50 PM                         | 2                         | 13   | 0     | 0 | 0                         | 18   | 1     | 0 | 0                      | 0    | 0     | 0 | 0                      | 0    | 0     | 0 | 0     | 34            | 417 |
| 3:55 PM                         | 1                         | 9    | 0     | 0 | 0                         | 9    | 0     | 0 | 0                      | 0    | 0     | 2 | 0                      | 2    | 0     | 0 | 0     | 23            | 397 |
| 4:00 PM                         | 0                         | 10   | 1     | 0 | 1                         | 15   | 0     | 0 | 0                      | 1    | 0     | 0 | 0                      | 0    | 0     | 0 | 0     | 28            | 390 |
| 4:05 PM                         | 1                         | 18   | 0     | 0 | 0                         | 9    | 0     | 0 | 0                      | 1    | 0     | 0 | 0                      | 1    | 0     | 0 | 0     | 30            | 387 |
| 4:10 PM                         | 1                         | 14   | 0     | 0 | 1                         | 16   | 3     | 0 | 0                      | 0    | 1     | 0 | 0                      | 3    | 0     | 1 | 0     | 40            | 383 |
| 4:15 PM                         | 1                         | 14   | 0     | 0 | 0                         | 10   | 0     | 0 | 0                      | 0    | 1     | 0 | 0                      | 0    | 0     | 1 | 0     | 27            | 369 |
| 4:20 PM                         | 0                         | 21   | 0     | 0 | 0                         | 9    | 1     | 0 | 0                      | 1    | 0     | 0 | 0                      | 2    | 0     | 0 | 0     | 34            | 374 |
| 4:25 PM                         | 2                         | 25   | 0     | 0 | 1                         | 17   | 1     | 0 | 0                      | 0    | 0     | 2 | 0                      | 1    | 0     | 0 | 0     | 49            | 382 |

**Attachment B**

| 5-Min Count Period Beginning At | Weatherby Rd (Northbound) |      |       |   | Weatherby Rd (Southbound) |      |       |   | Huntley Dr (Eastbound) |      |       |   | Huntley Dr (Westbound) |      |       |   | Total | Hourly Totals |
|---------------------------------|---------------------------|------|-------|---|---------------------------|------|-------|---|------------------------|------|-------|---|------------------------|------|-------|---|-------|---------------|
|                                 | Left                      | Thru | Right | U | Left                      | Thru | Right | U | Left                   | Thru | Right | U | Left                   | Thru | Right | U |       |               |
| 4:30 PM                         | 0                         | 13   | 0     | 0 | 0                         | 12   | 0     | 0 | 0                      | 0    | 1     | 0 | 0                      | 0    | 0     | 0 | 26    | 374           |
| 4:35 PM                         | 0                         | 7    | 0     | 0 | 0                         | 11   | 1     | 0 | 0                      | 0    | 0     | 0 | 0                      | 1    | 0     | 0 | 20    | 368           |
| 4:40 PM                         | 0                         | 19   | 0     | 0 | 0                         | 20   | 2     | 0 | 0                      | 0    | 0     | 0 | 0                      | 0    | 0     | 0 | 41    | 378           |
| 4:45 PM                         | 0                         | 17   | 1     | 0 | 0                         | 13   | 0     | 0 | 0                      | 0    | 0     | 0 | 0                      | 0    | 0     | 0 | 31    | 383           |
| 4:50 PM                         | 0                         | 13   | 0     | 0 | 0                         | 14   | 1     | 0 | 1                      | 0    | 0     | 0 | 1                      | 0    | 0     | 0 | 30    | 379           |
| 4:55 PM                         | 1                         | 11   | 1     | 0 | 0                         | 11   | 0     | 0 | 1                      | 2    | 2     | 0 | 0                      | 0    | 0     | 0 | 29    | 385           |
| 5:00 PM                         | 1                         | 4    | 0     | 0 | 0                         | 12   | 0     | 0 | 0                      | 0    | 1     | 0 | 1                      | 0    | 0     | 0 | 19    | 376           |
| 5:05 PM                         | 1                         | 2    | 0     | 0 | 0                         | 18   | 0     | 0 | 1                      | 0    | 0     | 0 | 0                      | 0    | 0     | 0 | 22    | 368           |
| 5:10 PM                         | 0                         | 1    | 0     | 0 | 0                         | 12   | 1     | 0 | 1                      | 0    | 0     | 0 | 0                      | 1    | 1     | 0 | 17    | 345           |
| 5:15 PM                         | 1                         | 2    | 3     | 0 | 1                         | 19   | 1     | 0 | 0                      | 0    | 0     | 0 | 0                      | 0    | 0     | 0 | 27    | 345           |
| 5:20 PM                         | 0                         | 1    | 0     | 0 | 0                         | 12   | 0     | 0 | 2                      | 0    | 0     | 0 | 0                      | 0    | 0     | 0 | 15    | 326           |
| 5:25 PM                         | 0                         | 0    | 0     | 0 | 0                         | 11   | 2     | 0 | 0                      | 1    | 0     | 0 | 0                      | 0    | 0     | 0 | 14    | 291           |
| 5:30 PM                         | 0                         | 3    | 0     | 0 | 1                         | 15   | 1     | 0 | 0                      | 1    | 1     | 1 | 0                      | 0    | 0     | 0 | 22    | 287           |
| 5:35 PM                         | 2                         | 6    | 0     | 0 | 0                         | 11   | 0     | 0 | 1                      | 0    | 0     | 0 | 0                      | 0    | 0     | 0 | 20    | 287           |
| 5:40 PM                         | 1                         | 8    | 0     | 0 | 1                         | 11   | 0     | 0 | 0                      | 0    | 1     | 0 | 2                      | 0    | 0     | 0 | 24    | 270           |
| 5:45 PM                         | 0                         | 8    | 1     | 0 | 0                         | 11   | 0     | 0 | 0                      | 0    | 0     | 0 | 1                      | 0    | 0     | 0 | 21    | 260           |
| 5:50 PM                         | 1                         | 4    | 0     | 0 | 0                         | 14   | 0     | 0 | 1                      | 1    | 1     | 0 | 0                      | 0    | 0     | 0 | 22    | 252           |
| 5:55 PM                         | 0                         | 3    | 0     | 0 | 0                         | 8    | 1     | 0 | 0                      | 0    | 2     | 0 | 1                      | 0    | 0     | 0 | 15    | 238           |
| 6:00 PM                         | 0                         | 3    | 0     | 0 | 0                         | 2    | 1     | 0 | 0                      | 0    | 0     | 0 | 1                      | 0    | 0     | 0 | 7     | 226           |
| 6:05 PM                         | 0                         | 2    | 1     | 0 | 0                         | 8    | 0     | 0 | 0                      | 0    | 0     | 0 | 2                      | 0    | 0     | 0 | 13    | 217           |
| 6:10 PM                         | 0                         | 4    | 0     | 0 | 0                         | 2    | 0     | 0 | 1                      | 0    | 3     | 0 | 0                      | 0    | 0     | 0 | 10    | 210           |
| 6:15 PM                         | 1                         | 5    | 0     | 0 | 0                         | 5    | 0     | 0 | 0                      | 0    | 0     | 0 | 0                      | 0    | 0     | 0 | 11    | 194           |
| 6:20 PM                         | 0                         | 2    | 1     | 0 | 0                         | 2    | 0     | 0 | 0                      | 0    | 0     | 0 | 0                      | 0    | 0     | 0 | 5     | 184           |
| 6:25 PM                         | 0                         | 2    | 0     | 0 | 0                         | 5    | 0     | 0 | 0                      | 0    | 0     | 0 | 0                      | 0    | 0     | 0 | 7     | 177           |
| 6:30 PM                         | 0                         | 6    | 0     | 0 | 0                         | 2    | 0     | 0 | 0                      | 0    | 1     | 0 | 0                      | 0    | 0     | 0 | 9     | 164           |
| 6:35 PM                         | 1                         | 2    | 0     | 0 | 0                         | 4    | 0     | 0 | 2                      | 0    | 1     | 0 | 0                      | 0    | 0     | 0 | 10    | 154           |
| 6:40 PM                         | 1                         | 0    | 0     | 0 | 0                         | 4    | 0     | 0 | 2                      | 0    | 0     | 0 | 0                      | 0    | 0     | 0 | 7     | 137           |
| 6:45 PM                         | 0                         | 2    | 0     | 0 | 0                         | 1    | 0     | 0 | 0                      | 0    | 1     | 0 | 0                      | 0    | 0     | 0 | 4     | 120           |
| 6:50 PM                         | 0                         | 2    | 0     | 0 | 0                         | 4    | 0     | 0 | 0                      | 0    | 0     | 0 | 0                      | 0    | 0     | 0 | 6     | 104           |
| 6:55 PM                         | 1                         | 2    | 0     | 0 | 0                         | 2    | 0     | 0 | 0                      | 0    | 0     | 0 | 0                      | 0    | 0     | 0 | 5     | 94            |
| 7:00 PM                         | 0                         | 0    | 0     | 0 | 0                         | 2    | 1     | 0 | 0                      | 0    | 0     | 0 | 0                      | 0    | 0     | 0 | 3     | 90            |
| 7:05 PM                         | 0                         | 2    | 0     | 0 | 0                         | 1    | 0     | 0 | 0                      | 0    | 0     | 0 | 0                      | 0    | 0     | 0 | 3     | 80            |
| 7:10 PM                         | 0                         | 0    | 0     | 0 | 0                         | 2    | 0     | 0 | 0                      | 0    | 0     | 0 | 0                      | 0    | 0     | 0 | 2     | 72            |
| 7:15 PM                         | 0                         | 2    | 0     | 0 | 0                         | 1    | 0     | 0 | 0                      | 0    | 0     | 0 | 0                      | 0    | 0     | 0 | 3     | 64            |
| 7:20 PM                         | 0                         | 1    | 1     | 0 | 0                         | 4    | 0     | 0 | 0                      | 0    | 0     | 0 | 0                      | 0    | 0     | 0 | 6     | 65            |
| 7:25 PM                         | 0                         | 0    | 0     | 0 | 0                         | 2    | 0     | 0 | 0                      | 1    | 1     | 0 | 0                      | 0    | 0     | 0 | 4     | 62            |
| 7:30 PM                         | 1                         | 0    | 0     | 0 | 1                         | 2    | 0     | 0 | 1                      | 0    | 1     | 0 | 0                      | 0    | 0     | 0 | 6     | 59            |
| 7:35 PM                         | 0                         | 1    | 0     | 0 | 0                         | 2    | 0     | 0 | 0                      | 0    | 0     | 0 | 0                      | 0    | 0     | 0 | 3     | 52            |
| 7:40 PM                         | 1                         | 0    | 0     | 0 | 1                         | 0    | 0     | 0 | 0                      | 0    | 0     | 0 | 0                      | 0    | 0     | 0 | 2     | 47            |
| 7:45 PM                         | 0                         | 2    | 0     | 0 | 0                         | 1    | 0     | 0 | 0                      | 0    | 0     | 0 | 0                      | 0    | 0     | 0 | 3     | 46            |
| 7:50 PM                         | 0                         | 0    | 0     | 0 | 0                         | 2    | 0     | 0 | 0                      | 0    | 0     | 0 | 0                      | 0    | 0     | 0 | 2     | 42            |
| 7:55 PM                         | 0                         | 1    | 1     | 0 | 0                         | 2    | 0     | 0 | 0                      | 1    | 0     | 0 | 0                      | 0    | 0     | 0 | 5     | 42            |
| 8:00 PM                         | 0                         | 2    | 0     | 0 | 0                         | 1    | 0     | 0 | 0                      | 0    | 0     | 0 | 0                      | 0    | 0     | 0 | 3     | 42            |
| 8:05 PM                         | 1                         | 2    | 0     | 0 | 0                         | 3    | 0     | 0 | 0                      | 0    | 0     | 0 | 0                      | 0    | 0     | 0 | 6     | 45            |
| 8:10 PM                         | 0                         | 1    | 0     | 0 | 0                         | 1    | 0     | 0 | 2                      | 0    | 0     | 0 | 0                      | 0    | 0     | 0 | 4     | 47            |
| 8:15 PM                         | 0                         | 0    | 0     | 0 | 0                         | 1    | 0     | 0 | 0                      | 0    | 0     | 0 | 0                      | 0    | 0     | 0 | 1     | 45            |
| 8:20 PM                         | 1                         | 0    | 0     | 0 | 0                         | 0    | 0     | 0 | 0                      | 0    | 1     | 0 | 0                      | 0    | 0     | 0 | 2     | 41            |
| 8:25 PM                         | 1                         | 1    | 0     | 0 | 0                         | 0    | 0     | 0 | 0                      | 0    | 0     | 0 | 0                      | 0    | 0     | 0 | 2     | 39            |
| 8:30 PM                         | 1                         | 0    | 0     | 0 | 0                         | 0    | 0     | 0 | 0                      | 0    | 0     | 0 | 1                      | 0    | 0     | 0 | 2     | 35            |
| 8:35 PM                         | 0                         | 1    | 0     | 0 | 0                         | 0    | 0     | 0 | 0                      | 0    | 0     | 0 | 0                      | 0    | 0     | 0 | 1     | 33            |
| 8:40 PM                         | 0                         | 0    | 0     | 0 | 0                         | 0    | 0     | 0 | 0                      | 0    | 0     | 0 | 2                      | 0    | 0     | 0 | 2     | 33            |
| 8:45 PM                         | 0                         | 2    | 0     | 0 | 0                         | 3    | 0     | 0 | 0                      | 0    | 0     | 0 | 0                      | 0    | 0     | 0 | 5     | 35            |
| 8:50 PM                         | 0                         | 0    | 0     | 0 | 0                         | 0    | 0     | 0 | 0                      | 0    | 0     | 0 | 0                      | 0    | 0     | 0 | 0     | 33            |
| 8:55 PM                         | 0                         | 0    | 0     | 0 | 0                         | 0    | 0     | 0 | 0                      | 0    | 0     | 0 | 0                      | 0    | 0     | 0 | 0     | 28            |
| 9:00 PM                         | 0                         | 1    | 0     | 0 | 0                         | 0    | 1     | 0 | 0                      | 0    | 0     | 0 | 0                      | 0    | 0     | 0 | 2     | 27            |
| 9:05 PM                         | 0                         | 0    | 0     | 0 | 0                         | 1    | 0     | 0 | 0                      | 0    | 0     | 0 | 0                      | 0    | 0     | 0 | 1     | 22            |
| 9:10 PM                         | 0                         | 0    | 1     | 0 | 0                         | 1    | 0     | 0 | 0                      | 0    | 0     | 0 | 0                      | 0    | 0     | 0 | 2     | 20            |
| 9:15 PM                         | 1                         | 2    | 1     | 0 | 0                         | 1    | 0     | 0 | 0                      | 0    | 0     | 0 | 0                      | 0    | 0     | 0 | 5     | 24            |
| 9:20 PM                         | 0                         | 2    | 0     | 0 | 0                         | 0    | 0     | 0 | 0                      | 0    | 0     | 0 | 0                      | 0    | 0     | 0 | 2     | 24            |
| 9:25 PM                         | 0                         | 0    | 0     | 0 | 0                         | 1    | 0     | 0 | 0                      | 0    | 1     | 0 | 0                      | 0    | 0     | 0 | 2     | 24            |
| 9:30 PM                         | 0                         | 0    | 0     | 0 | 0                         | 1    | 0     | 0 | 0                      | 0    | 0     | 0 | 0                      | 0    | 0     | 0 | 1     | 23            |
| 9:35 PM                         | 0                         | 1    | 0     | 0 | 0                         | 1    | 0     | 0 | 0                      | 0    | 0     | 0 | 0                      | 0    | 0     | 0 | 2     | 24            |
| 9:40 PM                         | 0                         | 0    | 0     | 0 | 0                         | 0    | 0     | 0 | 0                      | 0    | 0     | 0 | 0                      | 0    | 0     | 0 | 0     | 22            |
| 9:45 PM                         | 0                         | 0    | 0     | 0 | 0                         | 2    | 0     | 0 | 0                      | 0    | 0     | 0 | 0                      | 0    | 0     | 0 | 2     | 19            |
| 9:50 PM                         | 0                         | 0    | 0     | 0 | 0                         | 2    | 0     | 0 | 0                      | 0    | 0     | 0 | 0                      | 0    | 0     | 0 | 2     | 21            |
| 9:55 PM                         | 0                         | 0    | 0     | 0 | 0                         | 0    | 0     | 0 | 0                      | 0    | 0     | 0 | 0                      | 0    | 0     | 0 | 0     | 21            |
| Peak 15-Min Flowrates           | Northbound                |      |       |   | Southbound                |      |       |   | Eastbound              |      |       |   | Westbound              |      |       |   | Total |               |
|                                 | Left                      | Thru | Right | U | Left                      | Thru | Right | U | Left                   | Thru | Right | U | Left                   | Thru | Right | U |       |               |
| All Vehicles                    | 32                        | 284  | 12    | 0 | 0                         | 112  | 4     | 0 | 4                      | 8    | 8     | 0 | 8                      | 0    | 0     | 0 | 472   |               |
| Heavy Trucks                    | 0                         | 0    | 0     |   | 0                         | 0    | 0     |   | 0                      | 0    | 4     |   | 0                      | 0    | 0     |   | 4     |               |
| Buses                           |                           |      |       |   |                           |      |       |   |                        |      |       |   |                        |      |       |   |       |               |
| Pedestrians                     |                           | 0    |       |   |                           | 0    |       |   |                        | 0    |       |   |                        | 4    |       |   | 4     |               |
| Bicycles                        | 0                         | 0    | 0     |   | 0                         | 0    | 0     |   | 0                      | 0    | 0     |   | 0                      | 0    | 0     |   | 0     |               |
| Scoters                         |                           |      |       |   |                           |      |       |   |                        |      |       |   |                        |      |       |   |       |               |
| <i>Comments:</i>                |                           |      |       |   |                           |      |       |   |                        |      |       |   |                        |      |       |   |       |               |

LOCATION: Mac St -- Syracuse Ave  
 CITY/STATE: Orange, CA

QC JOB #: 16966425  
 DATE: Wed, Apr 9 2025

Peak-Hour: 4:15 PM -- 5:15 PM  
 Peak 15-Min: 4:45 PM -- 5:00 PM

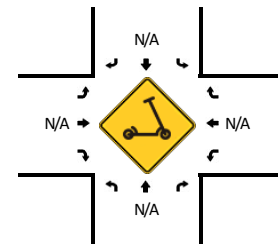
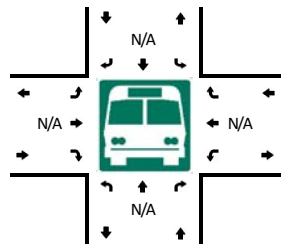
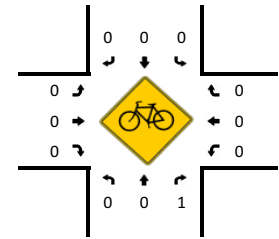
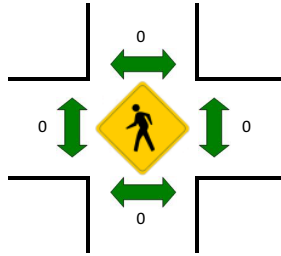
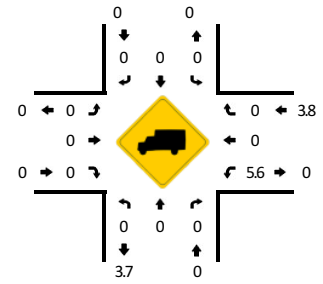
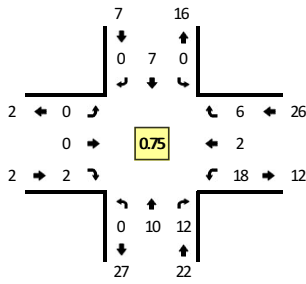

| 5-Min Count Period Beginning At | Mac St (Northbound) |      |       |   | Mac St (Southbound) |      |       |   | Syracuse Ave (Eastbound) |      |       |   | Syracuse Ave (Westbound) |      |       |   | Total | Hourly Totals |
|---------------------------------|---------------------|------|-------|---|---------------------|------|-------|---|--------------------------|------|-------|---|--------------------------|------|-------|---|-------|---------------|
|                                 | Left                | Thru | Right | U | Left                | Thru | Right | U | Left                     | Thru | Right | U | Left                     | Thru | Right | U |       |               |
| 6:00 AM                         | 0                   | 0    | 0     | 0 | 0                   | 0    | 0     | 0 | 0                        | 0    | 0     | 0 | 0                        | 0    | 0     | 0 | 0     | 0             |
| 6:05 AM                         | 0                   | 0    | 0     | 0 | 0                   | 0    | 0     | 0 | 0                        | 0    | 0     | 1 | 0                        | 0    | 0     | 0 | 0     | 2             |
| 6:10 AM                         | 0                   | 0    | 0     | 0 | 0                   | 0    | 0     | 0 | 0                        | 0    | 0     | 0 | 0                        | 0    | 0     | 0 | 0     | 0             |
| 6:15 AM                         | 0                   | 0    | 2     | 0 | 0                   | 0    | 0     | 0 | 0                        | 0    | 0     | 0 | 0                        | 0    | 0     | 0 | 0     | 2             |
| 6:20 AM                         | 0                   | 0    | 2     | 0 | 0                   | 0    | 0     | 0 | 0                        | 0    | 0     | 1 | 0                        | 0    | 0     | 0 | 0     | 3             |
| 6:25 AM                         | 0                   | 0    | 0     | 0 | 0                   | 0    | 0     | 0 | 0                        | 0    | 0     | 0 | 0                        | 0    | 0     | 0 | 0     | 0             |
| 6:30 AM                         | 0                   | 0    | 0     | 0 | 0                   | 0    | 0     | 0 | 0                        | 0    | 0     | 0 | 0                        | 0    | 0     | 0 | 0     | 0             |
| 6:35 AM                         | 0                   | 0    | 2     | 0 | 0                   | 0    | 0     | 0 | 0                        | 0    | 0     | 1 | 0                        | 0    | 0     | 0 | 0     | 3             |
| 6:40 AM                         | 0                   | 0    | 2     | 0 | 1                   | 0    | 0     | 0 | 0                        | 0    | 0     | 0 | 0                        | 0    | 1     | 0 | 0     | 4             |
| 6:45 AM                         | 0                   | 0    | 1     | 0 | 0                   | 0    | 0     | 0 | 0                        | 0    | 0     | 0 | 0                        | 0    | 0     | 0 | 0     | 1             |
| 6:50 AM                         | 0                   | 0    | 2     | 0 | 2                   | 0    | 0     | 0 | 0                        | 0    | 0     | 0 | 0                        | 0    | 0     | 0 | 0     | 4             |
| 6:55 AM                         | 0                   | 0    | 0     | 0 | 0                   | 0    | 0     | 0 | 0                        | 0    | 0     | 0 | 0                        | 1    | 0     | 0 | 0     | 1             |
| 7:00 AM                         | 0                   | 0    | 0     | 0 | 0                   | 1    | 0     | 0 | 0                        | 0    | 0     | 2 | 0                        | 0    | 0     | 0 | 0     | 4             |
| 7:05 AM                         | 0                   | 1    | 1     | 0 | 1                   | 0    | 0     | 0 | 0                        | 0    | 0     | 0 | 0                        | 0    | 0     | 0 | 0     | 4             |
| 7:10 AM                         | 0                   | 0    | 1     | 0 | 1                   | 1    | 0     | 0 | 0                        | 0    | 1     | 0 | 0                        | 0    | 0     | 0 | 0     | 3             |
| 7:15 AM                         | 0                   | 0    | 0     | 0 | 1                   | 0    | 0     | 0 | 0                        | 0    | 0     | 0 | 0                        | 0    | 0     | 0 | 0     | 1             |
| 7:20 AM                         | 0                   | 0    | 0     | 0 | 1                   | 0    | 0     | 0 | 0                        | 0    | 0     | 0 | 0                        | 0    | 0     | 0 | 0     | 1             |
| 7:25 AM                         | 0                   | 0    | 1     | 0 | 2                   | 0    | 0     | 0 | 0                        | 0    | 0     | 0 | 0                        | 0    | 1     | 0 | 0     | 4             |
| 7:30 AM                         | 0                   | 0    | 0     | 0 | 3                   | 0    | 0     | 0 | 0                        | 0    | 0     | 0 | 0                        | 1    | 0     | 0 | 0     | 4             |
| 7:35 AM                         | 1                   | 0    | 3     | 0 | 0                   | 0    | 0     | 0 | 0                        | 0    | 0     | 0 | 0                        | 2    | 0     | 0 | 0     | 6             |
| 7:40 AM                         | 0                   | 0    | 1     | 0 | 0                   | 1    | 0     | 0 | 0                        | 0    | 0     | 0 | 0                        | 2    | 0     | 0 | 0     | 4             |
| 7:45 AM                         | 0                   | 2    | 1     | 0 | 0                   | 0    | 0     | 0 | 0                        | 0    | 0     | 0 | 0                        | 0    | 0     | 1 | 0     | 4             |
| 7:50 AM                         | 0                   | 0    | 0     | 0 | 1                   | 1    | 0     | 0 | 0                        | 0    | 0     | 0 | 0                        | 1    | 0     | 0 | 0     | 3             |
| 7:55 AM                         | 0                   | 0    | 0     | 0 | 1                   | 0    | 0     | 0 | 0                        | 0    | 0     | 0 | 0                        | 0    | 0     | 1 | 0     | 2             |
| 8:00 AM                         | 0                   | 0    | 2     | 0 | 0                   | 1    | 0     | 0 | 0                        | 0    | 0     | 0 | 0                        | 0    | 0     | 0 | 0     | 3             |
| 8:05 AM                         | 0                   | 0    | 0     | 0 | 0                   | 0    | 0     | 0 | 0                        | 0    | 0     | 0 | 0                        | 1    | 0     | 0 | 0     | 1             |
| 8:10 AM                         | 0                   | 0    | 1     | 0 | 1                   | 0    | 0     | 0 | 0                        | 0    | 0     | 0 | 0                        | 1    | 0     | 0 | 0     | 3             |
| 8:15 AM                         | 0                   | 1    | 1     | 0 | 0                   | 0    | 0     | 0 | 0                        | 0    | 0     | 0 | 0                        | 1    | 0     | 0 | 0     | 3             |
| 8:20 AM                         | 0                   | 0    | 2     | 0 | 1                   | 0    | 0     | 0 | 0                        | 0    | 0     | 1 | 0                        | 1    | 0     | 2 | 0     | 7             |
| 8:25 AM                         | 0                   | 0    | 1     | 0 | 1                   | 0    | 0     | 0 | 0                        | 0    | 0     | 0 | 0                        | 2    | 0     | 0 | 0     | 4             |
| 8:30 AM                         | 0                   | 0    | 1     | 0 | 2                   | 0    | 0     | 0 | 0                        | 0    | 0     | 0 | 0                        | 1    | 0     | 0 | 0     | 4             |
| 8:35 AM                         | 0                   | 0    | 1     | 0 | 1                   | 0    | 0     | 0 | 0                        | 0    | 0     | 0 | 0                        | 0    | 0     | 0 | 0     | 2             |
| 8:40 AM                         | 0                   | 0    | 1     | 0 | 1                   | 1    | 0     | 0 | 0                        | 0    | 0     | 0 | 0                        | 1    | 0     | 0 | 0     | 4             |
| 8:45 AM                         | 1                   | 0    | 1     | 0 | 0                   | 1    | 0     | 0 | 0                        | 0    | 0     | 0 | 0                        | 0    | 0     | 0 | 0     | 3             |
| 8:50 AM                         | 0                   | 0    | 0     | 0 | 0                   | 1    | 0     | 0 | 0                        | 0    | 0     | 0 | 0                        | 0    | 0     | 0 | 0     | 1             |
| 8:55 AM                         | 0                   | 0    | 1     | 0 | 0                   | 1    | 0     | 0 | 0                        | 0    | 0     | 0 | 0                        | 2    | 0     | 0 | 0     | 4             |
| 9:00 AM                         | 0                   | 0    | 0     | 0 | 1                   | 0    | 0     | 0 | 0                        | 0    | 0     | 1 | 0                        | 2    | 0     | 0 | 0     | 4             |
| 9:05 AM                         | 0                   | 0    | 1     | 0 | 1                   | 0    | 0     | 0 | 0                        | 0    | 0     | 1 | 0                        | 0    | 0     | 0 | 0     | 3             |

Attachment B

| 5-Min Count Period Beginning At | Mac St (Northbound) |      |       |   | Mac St (Southbound) |      |       |   | Syracuse Ave (Eastbound) |      |       |   | Syracuse Ave (Westbound) |      |       |   | Total | Hourly Totals |
|---------------------------------|---------------------|------|-------|---|---------------------|------|-------|---|--------------------------|------|-------|---|--------------------------|------|-------|---|-------|---------------|
|                                 | Left                | Thru | Right | U | Left                | Thru | Right | U | Left                     | Thru | Right | U | Left                     | Thru | Right | U |       |               |
| 9:10 AM                         | 0                   | 1    | 0     | 0 | 1                   | 1    | 0     | 0 | 0                        | 0    | 0     | 0 | 0                        | 0    | 0     | 0 | 3     | 42            |
| 9:15 AM                         | 0                   | 0    | 0     | 0 | 0                   | 0    | 0     | 0 | 0                        | 0    | 0     | 0 | 0                        | 0    | 1     | 0 | 1     | 40            |
| 9:20 AM                         | 0                   | 1    | 1     | 0 | 0                   | 1    | 0     | 0 | 0                        | 0    | 0     | 0 | 2                        | 0    | 1     | 0 | 6     | 39            |
| 9:25 AM                         | 0                   | 0    | 0     | 0 | 0                   | 1    | 0     | 0 | 0                        | 0    | 0     | 0 | 0                        | 0    | 0     | 0 | 1     | 36            |
| 9:30 AM                         | 0                   | 0    | 1     | 0 | 0                   | 3    | 0     | 0 | 0                        | 0    | 0     | 0 | 1                        | 0    | 0     | 0 | 5     | 37            |
| 9:35 AM                         | 0                   | 0    | 2     | 0 | 0                   | 0    | 0     | 0 | 0                        | 0    | 0     | 0 | 0                        | 0    | 0     | 0 | 2     | 37            |
| 9:40 AM                         | 0                   | 0    | 0     | 0 | 0                   | 0    | 0     | 0 | 0                        | 0    | 1     | 0 | 1                        | 0    | 0     | 0 | 2     | 35            |
| 9:45 AM                         | 0                   | 0    | 1     | 0 | 0                   | 0    | 0     | 0 | 0                        | 0    | 0     | 0 | 1                        | 0    | 0     | 0 | 2     | 34            |
| 9:50 AM                         | 0                   | 0    | 1     | 0 | 0                   | 0    | 0     | 0 | 0                        | 0    | 0     | 0 | 4                        | 0    | 0     | 0 | 5     | 38            |
| 9:55 AM                         | 0                   | 1    | 1     | 0 | 0                   | 1    | 0     | 0 | 0                        | 0    | 0     | 0 | 0                        | 0    | 0     | 0 | 3     | 37            |
| 10:00 AM                        | 0                   | 0    | 1     | 0 | 1                   | 0    | 0     | 0 | 0                        | 0    | 0     | 0 | 0                        | 0    | 0     | 0 | 2     | 35            |
| 10:05 AM                        | 0                   | 0    | 1     | 0 | 0                   | 0    | 0     | 0 | 0                        | 0    | 0     | 0 | 0                        | 0    | 0     | 0 | 1     | 33            |
| 10:10 AM                        | 0                   | 0    | 2     | 0 | 0                   | 0    | 0     | 0 | 0                        | 0    | 0     | 0 | 0                        | 0    | 0     | 0 | 2     | 32            |
| 10:15 AM                        | 0                   | 0    | 0     | 0 | 0                   | 0    | 0     | 0 | 0                        | 0    | 0     | 0 | 0                        | 0    | 0     | 0 | 0     | 31            |
| 10:20 AM                        | 0                   | 0    | 2     | 0 | 0                   | 0    | 0     | 0 | 0                        | 0    | 0     | 0 | 1                        | 0    | 0     | 0 | 3     | 28            |
| 10:25 AM                        | 0                   | 1    | 1     | 0 | 0                   | 0    | 0     | 0 | 0                        | 0    | 0     | 0 | 1                        | 0    | 1     | 0 | 4     | 31            |
| 10:30 AM                        | 0                   | 0    | 1     | 0 | 0                   | 0    | 0     | 0 | 0                        | 0    | 0     | 0 | 2                        | 0    | 1     | 0 | 4     | 30            |
| 10:35 AM                        | 0                   | 0    | 1     | 0 | 0                   | 0    | 0     | 0 | 0                        | 0    | 0     | 0 | 1                        | 0    | 0     | 0 | 2     | 30            |
| 10:40 AM                        | 0                   | 0    | 1     | 0 | 0                   | 0    | 0     | 0 | 0                        | 0    | 0     | 0 | 2                        | 0    | 0     | 0 | 3     | 31            |
| 10:45 AM                        | 0                   | 0    | 0     | 0 | 0                   | 0    | 0     | 0 | 0                        | 0    | 0     | 0 | 0                        | 0    | 0     | 0 | 0     | 29            |
| 10:50 AM                        | 0                   | 0    | 2     | 0 | 0                   | 1    | 0     | 0 | 0                        | 0    | 0     | 0 | 1                        | 0    | 0     | 0 | 4     | 28            |
| 10:55 AM                        | 0                   | 0    | 2     | 0 | 1                   | 0    | 0     | 0 | 0                        | 0    | 0     | 0 | 1                        | 0    | 1     | 0 | 5     | 30            |
| 11:00 AM                        | 0                   | 0    | 1     | 0 | 0                   | 0    | 0     | 0 | 0                        | 0    | 0     | 0 | 0                        | 0    | 0     | 0 | 1     | 29            |
| 11:05 AM                        | 0                   | 0    | 1     | 0 | 0                   | 0    | 0     | 0 | 0                        | 0    | 0     | 0 | 1                        | 0    | 0     | 0 | 2     | 30            |
| 11:10 AM                        | 0                   | 1    | 0     | 0 | 1                   | 1    | 0     | 0 | 0                        | 0    | 0     | 0 | 1                        | 0    | 0     | 0 | 4     | 32            |
| 11:15 AM                        | 0                   | 0    | 0     | 0 | 1                   | 1    | 0     | 0 | 0                        | 0    | 0     | 0 | 1                        | 0    | 1     | 0 | 4     | 36            |
| 11:20 AM                        | 0                   | 0    | 0     | 0 | 0                   | 2    | 0     | 0 | 0                        | 0    | 0     | 0 | 1                        | 0    | 0     | 0 | 3     | 36            |
| 11:25 AM                        | 0                   | 0    | 1     | 0 | 0                   | 0    | 0     | 0 | 0                        | 0    | 0     | 0 | 2                        | 0    | 0     | 0 | 3     | 35            |
| 11:30 AM                        | 0                   | 1    | 0     | 0 | 0                   | 0    | 0     | 0 | 0                        | 0    | 0     | 0 | 2                        | 0    | 0     | 0 | 3     | 34            |
| 11:35 AM                        | 0                   | 1    | 0     | 0 | 1                   | 0    | 0     | 0 | 0                        | 0    | 0     | 0 | 3                        | 0    | 0     | 0 | 5     | 37            |
| 11:40 AM                        | 0                   | 0    | 0     | 0 | 0                   | 0    | 0     | 0 | 0                        | 0    | 0     | 0 | 0                        | 1    | 0     | 0 | 1     | 35            |
| 11:45 AM                        | 0                   | 0    | 1     | 0 | 0                   | 0    | 0     | 0 | 0                        | 0    | 0     | 0 | 1                        | 0    | 0     | 0 | 2     | 37            |
| 11:50 AM                        | 0                   | 0    | 1     | 0 | 1                   | 0    | 0     | 0 | 0                        | 0    | 0     | 0 | 0                        | 0    | 1     | 0 | 3     | 36            |
| 11:55 AM                        | 0                   | 0    | 1     | 0 | 0                   | 0    | 0     | 0 | 0                        | 0    | 0     | 0 | 0                        | 0    | 2     | 0 | 3     | 34            |
| 12:00 PM                        | 0                   | 0    | 0     | 0 | 0                   | 2    | 0     | 0 | 0                        | 0    | 0     | 0 | 0                        | 0    | 0     | 0 | 2     | 35            |
| 12:05 PM                        | 0                   | 0    | 0     | 0 | 0                   | 0    | 0     | 0 | 0                        | 0    | 0     | 0 | 1                        | 0    | 0     | 0 | 1     | 34            |
| 12:10 PM                        | 0                   | 0    | 1     | 0 | 0                   | 0    | 0     | 0 | 0                        | 0    | 0     | 0 | 1                        | 0    | 0     | 0 | 2     | 32            |
| 12:15 PM                        | 0                   | 1    | 1     | 0 | 0                   | 0    | 0     | 0 | 0                        | 0    | 0     | 0 | 2                        | 0    | 0     | 0 | 4     | 32            |
| 12:20 PM                        | 0                   | 0    | 1     | 0 | 0                   | 0    | 0     | 0 | 0                        | 0    | 0     | 0 | 0                        | 0    | 0     | 0 | 1     | 30            |
| 12:25 PM                        | 0                   | 0    | 1     | 0 | 0                   | 2    | 0     | 0 | 0                        | 0    | 0     | 0 | 1                        | 0    | 0     | 0 | 4     | 31            |
| 12:30 PM                        | 0                   | 3    | 0     | 0 | 1                   | 0    | 0     | 0 | 0                        | 0    | 0     | 0 | 0                        | 0    | 0     | 0 | 4     | 32            |
| 12:35 PM                        | 0                   | 1    | 0     | 0 | 0                   | 0    | 0     | 0 | 0                        | 0    | 0     | 0 | 0                        | 0    | 2     | 0 | 3     | 30            |
| 12:40 PM                        | 0                   | 1    | 0     | 0 | 0                   | 0    | 0     | 0 | 0                        | 0    | 0     | 0 | 2                        | 0    | 0     | 0 | 3     | 32            |
| 12:45 PM                        | 0                   | 0    | 2     | 0 | 1                   | 1    | 0     | 0 | 0                        | 0    | 0     | 0 | 1                        | 0    | 0     | 0 | 5     | 35            |
| 12:50 PM                        | 0                   | 1    | 1     | 0 | 1                   | 0    | 0     | 0 | 0                        | 0    | 0     | 0 | 0                        | 0    | 0     | 0 | 3     | 35            |
| 12:55 PM                        | 0                   | 0    | 2     | 0 | 0                   | 1    | 0     | 0 | 0                        | 0    | 0     | 0 | 1                        | 0    | 0     | 0 | 4     | 36            |
| 1:00 PM                         | 0                   | 1    | 1     | 0 | 0                   | 0    | 0     | 0 | 0                        | 0    | 0     | 0 | 0                        | 0    | 0     | 0 | 2     | 36            |
| 1:05 PM                         | 0                   | 0    | 2     | 0 | 1                   | 0    | 0     | 0 | 0                        | 0    | 0     | 0 | 0                        | 0    | 1     | 0 | 4     | 39            |
| 1:10 PM                         | 0                   | 0    | 3     | 0 | 0                   | 1    | 0     | 0 | 0                        | 0    | 0     | 0 | 1                        | 0    | 0     | 0 | 5     | 42            |
| 1:15 PM                         | 0                   | 0    | 1     | 0 | 0                   | 0    | 0     | 0 | 0                        | 0    | 0     | 0 | 0                        | 0    | 1     | 0 | 2     | 40            |
| 1:20 PM                         | 0                   | 0    | 0     | 0 | 0                   | 0    | 0     | 0 | 0                        | 0    | 0     | 0 | 0                        | 0    | 0     | 0 | 0     | 39            |
| 1:25 PM                         | 0                   | 0    | 1     | 0 | 1                   | 0    | 0     | 0 | 0                        | 0    | 0     | 0 | 2                        | 0    | 0     | 0 | 4     | 39            |
| 1:30 PM                         | 0                   | 0    | 0     | 0 | 1                   | 1    | 0     | 0 | 0                        | 0    | 0     | 0 | 0                        | 0    | 0     | 0 | 2     | 37            |
| 1:35 PM                         | 0                   | 0    | 2     | 0 | 0                   | 1    | 0     | 0 | 0                        | 0    | 0     | 0 | 2                        | 0    | 0     | 0 | 5     | 39            |
| 1:40 PM                         | 0                   | 1    | 0     | 0 | 1                   | 0    | 0     | 0 | 0                        | 0    | 0     | 0 | 0                        | 0    | 0     | 0 | 2     | 38            |
| 1:45 PM                         | 0                   | 1    | 1     | 0 | 0                   | 0    | 0     | 0 | 0                        | 0    | 0     | 0 | 1                        | 1    | 0     | 0 | 4     | 37            |
| 1:50 PM                         | 0                   | 1    | 0     | 0 | 0                   | 0    | 0     | 0 | 0                        | 0    | 0     | 0 | 1                        | 0    | 0     | 0 | 2     | 36            |
| 1:55 PM                         | 0                   | 0    | 1     | 0 | 0                   | 1    | 0     | 0 | 0                        | 0    | 0     | 0 | 0                        | 0    | 2     | 0 | 4     | 36            |
| 2:00 PM                         | 0                   | 0    | 0     | 0 | 1                   | 0    | 0     | 0 | 0                        | 0    | 0     | 0 | 0                        | 0    | 0     | 0 | 1     | 35            |
| 2:05 PM                         | 0                   | 0    | 0     | 0 | 1                   | 0    | 0     | 0 | 0                        | 0    | 0     | 0 | 0                        | 0    | 1     | 0 | 2     | 33            |
| 2:10 PM                         | 0                   | 1    | 0     | 0 | 0                   | 1    | 0     | 0 | 0                        | 0    | 0     | 0 | 3                        | 0    | 0     | 0 | 5     | 33            |
| 2:15 PM                         | 0                   | 0    | 1     | 0 | 0                   | 0    | 0     | 0 | 0                        | 0    | 0     | 0 | 2                        | 0    | 0     | 0 | 3     | 34            |
| 2:20 PM                         | 0                   | 0    | 1     | 0 | 0                   | 0    | 0     | 0 | 0                        | 0    | 0     | 0 | 1                        | 0    | 1     | 0 | 3     | 37            |
| 2:25 PM                         | 0                   | 0    | 2     | 0 | 1                   | 0    | 0     | 0 | 0                        | 0    | 0     | 0 | 0                        | 0    | 1     | 0 | 4     | 37            |
| 2:30 PM                         | 0                   | 1    | 0     | 0 | 0                   | 0    | 0     | 0 | 0                        | 0    | 0     | 0 | 1                        | 0    | 0     | 0 | 2     | 37            |
| 2:35 PM                         | 0                   | 0    | 2     | 0 | 0                   | 0    | 0     | 0 | 0                        | 0    | 0     | 0 | 0                        | 0    | 1     | 0 | 3     | 35            |
| 2:40 PM                         | 0                   | 1    | 0     | 0 | 2                   | 0    | 0     | 0 | 0                        | 0    | 0     | 0 | 1                        | 0    | 0     | 0 | 4     | 37            |
| 2:45 PM                         | 0                   | 0    | 0     | 0 | 0                   | 0    | 0     | 0 | 0                        | 0    | 0     | 0 | 1                        | 0    | 0     | 0 | 1     | 34            |
| 2:50 PM                         | 0                   | 0    | 2     | 0 | 0                   | 1    | 0     | 0 | 0                        | 0    | 0     | 0 | 3                        | 0    | 1     | 0 | 7     | 39            |
| 2:55 PM                         | 0                   | 1    | 1     | 0 | 0                   | 1    | 0     | 0 | 0                        | 0    | 0     | 0 | 0                        | 0    | 0     | 0 | 3     | 38            |
| 3:00 PM                         | 0                   | 0    | 0     | 0 | 1                   | 1    | 0     | 0 | 0                        | 0    | 0     | 0 | 0                        | 0    | 1     | 0 | 3     | 40            |
| 3:05 PM                         | 0                   | 0    | 1     | 0 | 0                   | 0    | 0     | 0 | 0                        | 0    | 0     | 0 | 0                        | 0    | 0     | 0 | 1     | 39            |
| 3:10 PM                         | 0                   | 1    | 0     | 0 | 0                   | 0    | 0     | 0 | 0                        | 0    | 0     | 0 | 0                        | 0    | 0     | 0 | 1     | 35            |
| 3:15 PM                         | 0                   | 0    | 1     | 0 | 0                   | 0    | 0     | 0 | 0                        | 0    | 0     | 0 | 1                        | 0    | 0     | 0 | 2     | 34            |
| 3:20 PM                         | 0                   | 0    | 3     | 0 | 0                   | 1    | 0     | 0 | 0                        | 0    | 0     | 0 | 1                        | 0    | 1     | 0 | 6     | 37            |
| 3:25 PM                         | 0                   | 0    | 1     | 0 | 0                   | 0    | 0     | 0 | 0                        | 0    | 0     | 0 | 0                        | 0    | 0     | 0 | 1     | 34            |
| 3:30 PM                         | 0                   | 0    | 0     | 0 | 0                   | 0    | 0     | 0 | 0                        | 0    | 0     | 0 | 0                        | 0    | 2     | 0 | 2     | 34            |
| 3:35 PM                         | 0                   | 0    | 2     | 0 | 1                   | 0    | 0     | 0 | 0                        | 0    | 0     | 0 | 2                        | 0    | 0     | 0 | 5     | 36            |
| 3:40 PM                         | 0                   | 0    | 1     | 0 | 0                   | 0    | 0     | 0 | 0                        | 0    | 0     | 0 | 0                        | 0    | 0     | 0 | 1     | 33            |
| 3:45 PM                         | 0                   | 0    | 0     | 0 | 0                   | 0    | 0     | 0 | 0                        | 0    | 0     | 0 | 3                        | 0    | 1     | 0 | 4     | 36            |
| 3:50 PM                         | 0                   | 1    | 1     | 0 | 0                   | 2    | 0     | 0 | 0                        | 0    | 0     | 0 | 1                        | 0    | 1     | 0 | 6     | 35            |
| 3:55 PM                         | 0                   | 0    | 2     | 0 | 0                   | 0    | 0     | 0 | 0                        | 0    | 0     | 0 | 1                        | 0    | 0     | 0 | 3     | 35            |
| 4:00 PM                         | 0                   | 0    | 0     | 0 | 1                   | 0    | 0     | 0 | 0                        | 0    | 0     | 0 | 0                        | 1    | 1     | 0 | 3     | 35            |
| 4:05 PM                         | 0                   | 0    | 0     | 0 | 0                   | 1    | 0     | 0 | 0                        | 0    | 0     | 0 | 1                        | 0    | 0     | 0 | 2     | 36            |
| 4:10 PM                         | 0                   | 0    | 0     | 0 | 0                   | 1    | 0     | 0 | 0                        | 0    | 0     | 0 | 0                        | 0    | 0     | 0 | 1     | 36            |
| 4:15 PM                         | 0                   | 2    | 2     | 0 | 0                   | 0    | 0     | 0 | 0                        | 0    | 0     | 0 | 2                        | 0    | 1     | 0 | 7     | 41            |
| 4:20 PM                         | 0                   | 0    | 2     | 0 | 0                   | 1    | 0     | 0 | 0                        | 0    | 0     | 0 | 1                        | 0    | 0     | 0 | 4     | 39            |
| 4:25 PM                         | 0                   | 0    | 0     | 0 | 0                   | 1    | 0     | 0 | 0                        | 0    | 0     | 0 | 0                        | 0    | 1     | 0 | 2     | 40            |

**Attachment B**

| 5-Min Count Period Beginning At | Mac St (Northbound) |      |       |   | Mac St (Southbound) |      |       |   | Syracuse Ave (Eastbound) |      |       |   | Syracuse Ave (Westbound) |      |       |   | Total | Hourly Totals |
|---------------------------------|---------------------|------|-------|---|---------------------|------|-------|---|--------------------------|------|-------|---|--------------------------|------|-------|---|-------|---------------|
|                                 | Left                | Thru | Right | U | Left                | Thru | Right | U | Left                     | Thru | Right | U | Left                     | Thru | Right | U |       |               |
| 4:30 PM                         | 0                   | 0    | 0     | 0 | 0                   | 0    | 0     | 0 | 0                        | 0    | 0     | 0 | 1                        | 0    | 0     | 0 | 1     | 39            |
| 4:35 PM                         | 0                   | 2    | 2     | 0 | 0                   | 0    | 0     | 0 | 0                        | 0    | 0     | 0 | 2                        | 0    | 1     | 0 | 7     | 41            |
| 4:40 PM                         | 0                   | 2    | 0     | 0 | 0                   | 0    | 0     | 0 | 0                        | 0    | 0     | 0 | 0                        | 1    | 0     | 0 | 3     | 43            |
| 4:45 PM                         | 0                   | 1    | 1     | 0 | 0                   | 2    | 0     | 0 | 0                        | 0    | 2     | 0 | 1                        | 0    | 1     | 0 | 8     | 47            |
| 4:50 PM                         | 0                   | 0    | 1     | 0 | 0                   | 0    | 0     | 0 | 0                        | 0    | 0     | 0 | 4                        | 0    | 1     | 0 | 6     | 47            |
| 4:55 PM                         | 0                   | 1    | 0     | 0 | 0                   | 2    | 0     | 0 | 0                        | 0    | 0     | 0 | 2                        | 0    | 0     | 0 | 5     | 49            |
| 5:00 PM                         | 0                   | 2    | 2     | 0 | 0                   | 0    | 0     | 0 | 0                        | 0    | 0     | 0 | 1                        | 1    | 1     | 0 | 7     | 53            |
| 5:05 PM                         | 0                   | 0    | 1     | 0 | 0                   | 0    | 0     | 0 | 0                        | 0    | 0     | 0 | 1                        | 0    | 0     | 0 | 2     | 53            |
| 5:10 PM                         | 0                   | 0    | 1     | 0 | 0                   | 1    | 0     | 0 | 0                        | 0    | 0     | 0 | 3                        | 0    | 0     | 0 | 5     | 57            |
| 5:15 PM                         | 0                   | 0    | 0     | 0 | 0                   | 0    | 0     | 0 | 0                        | 0    | 0     | 0 | 2                        | 0    | 0     | 0 | 2     | 52            |
| 5:20 PM                         | 0                   | 0    | 2     | 0 | 0                   | 0    | 0     | 0 | 0                        | 0    | 0     | 0 | 0                        | 0    | 0     | 0 | 2     | 50            |
| 5:25 PM                         | 0                   | 0    | 1     | 0 | 0                   | 0    | 0     | 0 | 0                        | 0    | 0     | 0 | 2                        | 0    | 0     | 0 | 3     | 51            |
| 5:30 PM                         | 0                   | 0    | 1     | 0 | 0                   | 0    | 0     | 0 | 0                        | 0    | 0     | 0 | 1                        | 0    | 0     | 0 | 2     | 52            |
| 5:35 PM                         | 0                   | 0    | 0     | 0 | 1                   | 0    | 0     | 0 | 0                        | 1    | 0     | 0 | 0                        | 0    | 3     | 0 | 5     | 50            |
| 5:40 PM                         | 0                   | 0    | 3     | 0 | 0                   | 0    | 0     | 0 | 0                        | 0    | 0     | 0 | 2                        | 0    | 1     | 0 | 6     | 53            |
| 5:45 PM                         | 2                   | 0    | 3     | 0 | 0                   | 0    | 0     | 0 | 0                        | 1    | 0     | 0 | 1                        | 1    | 1     | 0 | 9     | 54            |
| 5:50 PM                         | 0                   | 0    | 1     | 0 | 0                   | 0    | 0     | 0 | 0                        | 0    | 0     | 0 | 0                        | 0    | 1     | 0 | 2     | 50            |
| 5:55 PM                         | 0                   | 0    | 0     | 0 | 0                   | 0    | 0     | 0 | 0                        | 0    | 0     | 0 | 1                        | 0    | 0     | 0 | 1     | 46            |
| 6:00 PM                         | 1                   | 0    | 2     | 0 | 0                   | 1    | 0     | 0 | 0                        | 0    | 0     | 0 | 0                        | 0    | 0     | 0 | 4     | 43            |
| 6:05 PM                         | 0                   | 1    | 0     | 0 | 0                   | 0    | 0     | 0 | 0                        | 0    | 0     | 0 | 2                        | 0    | 0     | 0 | 3     | 44            |
| 6:10 PM                         | 0                   | 0    | 1     | 0 | 0                   | 0    | 0     | 0 | 0                        | 0    | 0     | 0 | 2                        | 0    | 0     | 0 | 3     | 42            |
| 6:15 PM                         | 0                   | 0    | 0     | 0 | 0                   | 0    | 0     | 0 | 0                        | 0    | 0     | 0 | 1                        | 1    | 0     | 0 | 2     | 42            |
| 6:20 PM                         | 0                   | 0    | 0     | 0 | 0                   | 0    | 0     | 0 | 0                        | 0    | 1     | 0 | 1                        | 0    | 1     | 0 | 3     | 43            |
| 6:25 PM                         | 0                   | 0    | 0     | 0 | 0                   | 1    | 0     | 0 | 0                        | 0    | 0     | 0 | 2                        | 0    | 0     | 0 | 3     | 43            |
| 6:30 PM                         | 0                   | 1    | 0     | 0 | 0                   | 1    | 0     | 0 | 0                        | 0    | 0     | 0 | 1                        | 0    | 0     | 0 | 3     | 44            |
| 6:35 PM                         | 0                   | 0    | 0     | 0 | 0                   | 0    | 0     | 0 | 0                        | 0    | 0     | 0 | 1                        | 0    | 0     | 0 | 1     | 40            |
| 6:40 PM                         | 0                   | 0    | 2     | 0 | 0                   | 0    | 0     | 0 | 0                        | 0    | 0     | 0 | 0                        | 0    | 0     | 0 | 2     | 36            |
| 6:45 PM                         | 0                   | 2    | 0     | 0 | 0                   | 0    | 0     | 0 | 0                        | 0    | 0     | 0 | 1                        | 1    | 0     | 0 | 4     | 31            |
| 6:50 PM                         | 0                   | 0    | 0     | 0 | 1                   | 1    | 0     | 0 | 0                        | 0    | 0     | 0 | 1                        | 0    | 2     | 0 | 5     | 34            |
| 6:55 PM                         | 0                   | 0    | 3     | 0 | 0                   | 0    | 0     | 0 | 0                        | 0    | 0     | 0 | 0                        | 0    | 0     | 0 | 3     | 36            |
| 7:00 PM                         | 0                   | 0    | 0     | 0 | 0                   | 1    | 0     | 0 | 0                        | 0    | 0     | 0 | 2                        | 0    | 0     | 0 | 3     | 35            |
| 7:05 PM                         | 0                   | 1    | 1     | 0 | 0                   | 1    | 0     | 0 | 0                        | 0    | 1     | 0 | 1                        | 0    | 1     | 0 | 6     | 38            |
| 7:10 PM                         | 0                   | 1    | 1     | 0 | 2                   | 0    | 0     | 0 | 0                        | 0    | 0     | 0 | 0                        | 0    | 0     | 0 | 4     | 39            |
| 7:15 PM                         | 0                   | 2    | 1     | 0 | 1                   | 1    | 0     | 0 | 0                        | 0    | 0     | 0 | 4                        | 0    | 0     | 0 | 9     | 46            |
| 7:20 PM                         | 0                   | 0    | 2     | 0 | 0                   | 0    | 0     | 0 | 0                        | 0    | 0     | 0 | 1                        | 0    | 0     | 0 | 3     | 46            |
| 7:25 PM                         | 0                   | 0    | 0     | 0 | 0                   | 0    | 0     | 0 | 0                        | 0    | 0     | 0 | 0                        | 0    | 1     | 0 | 1     | 44            |
| 7:30 PM                         | 0                   | 0    | 0     | 0 | 0                   | 0    | 0     | 0 | 0                        | 0    | 0     | 0 | 1                        | 0    | 0     | 0 | 1     | 42            |
| 7:35 PM                         | 0                   | 1    | 0     | 0 | 0                   | 1    | 0     | 0 | 0                        | 0    | 0     | 0 | 0                        | 0    | 0     | 0 | 2     | 43            |
| 7:40 PM                         | 0                   | 0    | 4     | 0 | 0                   | 0    | 0     | 0 | 0                        | 0    | 0     | 0 | 3                        | 2    | 0     | 0 | 9     | 50            |
| 7:45 PM                         | 0                   | 0    | 0     | 0 | 0                   | 0    | 0     | 0 | 0                        | 0    | 0     | 0 | 3                        | 0    | 0     | 0 | 3     | 49            |
| 7:50 PM                         | 0                   | 1    | 0     | 0 | 1                   | 0    | 0     | 0 | 0                        | 0    | 0     | 0 | 0                        | 0    | 0     | 0 | 2     | 46            |
| 7:55 PM                         | 0                   | 1    | 0     | 0 | 0                   | 0    | 0     | 0 | 0                        | 0    | 0     | 0 | 1                        | 0    | 0     | 0 | 2     | 45            |
| 8:00 PM                         | 0                   | 1    | 0     | 0 | 0                   | 0    | 0     | 0 | 0                        | 0    | 0     | 0 | 0                        | 0    | 0     | 0 | 1     | 43            |
| 8:05 PM                         | 0                   | 0    | 2     | 0 | 1                   | 0    | 0     | 0 | 0                        | 0    | 0     | 0 | 3                        | 0    | 1     | 0 | 7     | 44            |
| 8:10 PM                         | 0                   | 0    | 0     | 0 | 0                   | 1    | 0     | 0 | 0                        | 0    | 0     | 0 | 0                        | 0    | 1     | 0 | 2     | 42            |
| 8:15 PM                         | 0                   | 1    | 1     | 0 | 0                   | 1    | 0     | 0 | 0                        | 0    | 0     | 0 | 1                        | 0    | 0     | 0 | 4     | 37            |
| 8:20 PM                         | 0                   | 0    | 0     | 0 | 0                   | 0    | 0     | 0 | 0                        | 0    | 0     | 0 | 1                        | 0    | 1     | 0 | 2     | 36            |
| 8:25 PM                         | 0                   | 1    | 1     | 0 | 0                   | 1    | 0     | 0 | 0                        | 0    | 0     | 0 | 2                        | 0    | 0     | 0 | 5     | 40            |
| 8:30 PM                         | 0                   | 0    | 0     | 0 | 0                   | 0    | 0     | 0 | 0                        | 0    | 0     | 0 | 0                        | 0    | 0     | 0 | 0     | 39            |
| 8:35 PM                         | 0                   | 1    | 2     | 0 | 0                   | 0    | 0     | 0 | 0                        | 0    | 0     | 0 | 0                        | 0    | 0     | 0 | 3     | 40            |
| 8:40 PM                         | 0                   | 2    | 0     | 0 | 1                   | 1    | 0     | 0 | 0                        | 0    | 0     | 0 | 0                        | 0    | 0     | 0 | 4     | 35            |
| 8:45 PM                         | 0                   | 1    | 1     | 0 | 0                   | 1    | 0     | 0 | 0                        | 0    | 0     | 0 | 0                        | 0    | 0     | 0 | 3     | 35            |
| 8:50 PM                         | 0                   | 0    | 0     | 0 | 2                   | 1    | 0     | 0 | 0                        | 0    | 0     | 0 | 0                        | 0    | 0     | 0 | 3     | 36            |
| 8:55 PM                         | 0                   | 0    | 1     | 0 | 0                   | 1    | 0     | 0 | 0                        | 0    | 0     | 0 | 1                        | 0    | 0     | 0 | 3     | 37            |
| 9:00 PM                         | 0                   | 0    | 1     | 0 | 0                   | 0    | 0     | 0 | 0                        | 0    | 0     | 0 | 1                        | 0    | 2     | 0 | 4     | 40            |
| 9:05 PM                         | 0                   | 0    | 1     | 0 | 0                   | 1    | 0     | 0 | 0                        | 0    | 0     | 0 | 1                        | 0    | 0     | 0 | 3     | 36            |
| 9:10 PM                         | 0                   | 0    | 0     | 0 | 0                   | 0    | 0     | 0 | 0                        | 0    | 0     | 0 | 1                        | 0    | 0     | 0 | 1     | 35            |
| 9:15 PM                         | 0                   | 3    | 1     | 0 | 2                   | 0    | 0     | 0 | 0                        | 0    | 0     | 0 | 0                        | 0    | 0     | 0 | 6     | 37            |
| 9:20 PM                         | 0                   | 0    | 0     | 0 | 0                   | 0    | 0     | 0 | 0                        | 0    | 0     | 0 | 0                        | 0    | 0     | 0 | 0     | 35            |
| 9:25 PM                         | 0                   | 1    | 1     | 0 | 0                   | 0    | 0     | 0 | 0                        | 0    | 0     | 0 | 0                        | 0    | 0     | 0 | 2     | 32            |
| 9:30 PM                         | 0                   | 0    | 2     | 0 | 0                   | 0    | 0     | 0 | 0                        | 0    | 0     | 0 | 1                        | 0    | 0     | 0 | 3     | 35            |
| 9:35 PM                         | 0                   | 0    | 0     | 0 | 0                   | 0    | 0     | 0 | 0                        | 0    | 0     | 0 | 2                        | 0    | 0     | 0 | 2     | 34            |
| 9:40 PM                         | 0                   | 0    | 0     | 0 | 0                   | 0    | 0     | 0 | 0                        | 0    | 0     | 0 | 2                        | 0    | 1     | 0 | 3     | 33            |
| 9:45 PM                         | 0                   | 0    | 1     | 0 | 0                   | 0    | 0     | 0 | 0                        | 0    | 0     | 0 | 0                        | 0    | 0     | 0 | 1     | 31            |
| 9:50 PM                         | 0                   | 1    | 0     | 0 | 0                   | 0    | 0     | 0 | 0                        | 0    | 0     | 0 | 1                        | 0    | 1     | 0 | 3     | 31            |
| 9:55 PM                         | 0                   | 1    | 2     | 0 | 0                   | 1    | 0     | 0 | 0                        | 0    | 0     | 0 | 0                        | 0    | 0     | 0 | 4     | 32            |
| Peak 15-Min Flowrates           | Northbound          |      |       |   | Southbound          |      |       |   | Eastbound                |      |       |   | Westbound                |      |       |   | Total |               |
|                                 | Left                | Thru | Right | U | Left                | Thru | Right | U | Left                     | Thru | Right | U | Left                     | Thru | Right | U |       |               |
| All Vehicles                    | 0                   | 8    | 8     | 0 | 0                   | 16   | 0     | 0 | 0                        | 0    | 0     | 8 | 0                        | 8    | 0     | 0 | 76    |               |
| Heavy Trucks                    | 0                   | 0    | 0     | 0 | 0                   | 0    | 0     | 0 | 0                        | 0    | 0     | 0 | 4                        | 0    | 0     | 0 | 4     |               |
| Buses                           |                     |      |       |   |                     |      |       |   |                          |      |       |   |                          |      |       |   |       |               |
| Pedestrians                     |                     | 0    |       |   |                     | 0    |       |   |                          |      | 0     |   |                          | 0    |       |   | 0     |               |
| Bicycles                        | 0                   | 0    | 0     |   | 0                   | 0    | 0     |   |                          | 0    | 0     | 0 | 0                        | 0    | 0     |   | 0     |               |
| Scoters                         |                     |      |       |   |                     |      |       |   |                          |      |       |   |                          |      |       |   |       |               |
| <i>Comments:</i>                |                     |      |       |   |                     |      |       |   |                          |      |       |   |                          |      |       |   |       |               |

Type of peak hour being reported: Intersection Peak

Method for determining peak hour: Total Entering Volume

LOCATION: Chamberlain Ave -- W Harle Ave  
 CITY/STATE: Orange, CA

QC JOB #: 16966426  
 DATE: Wed, Apr 9 2025

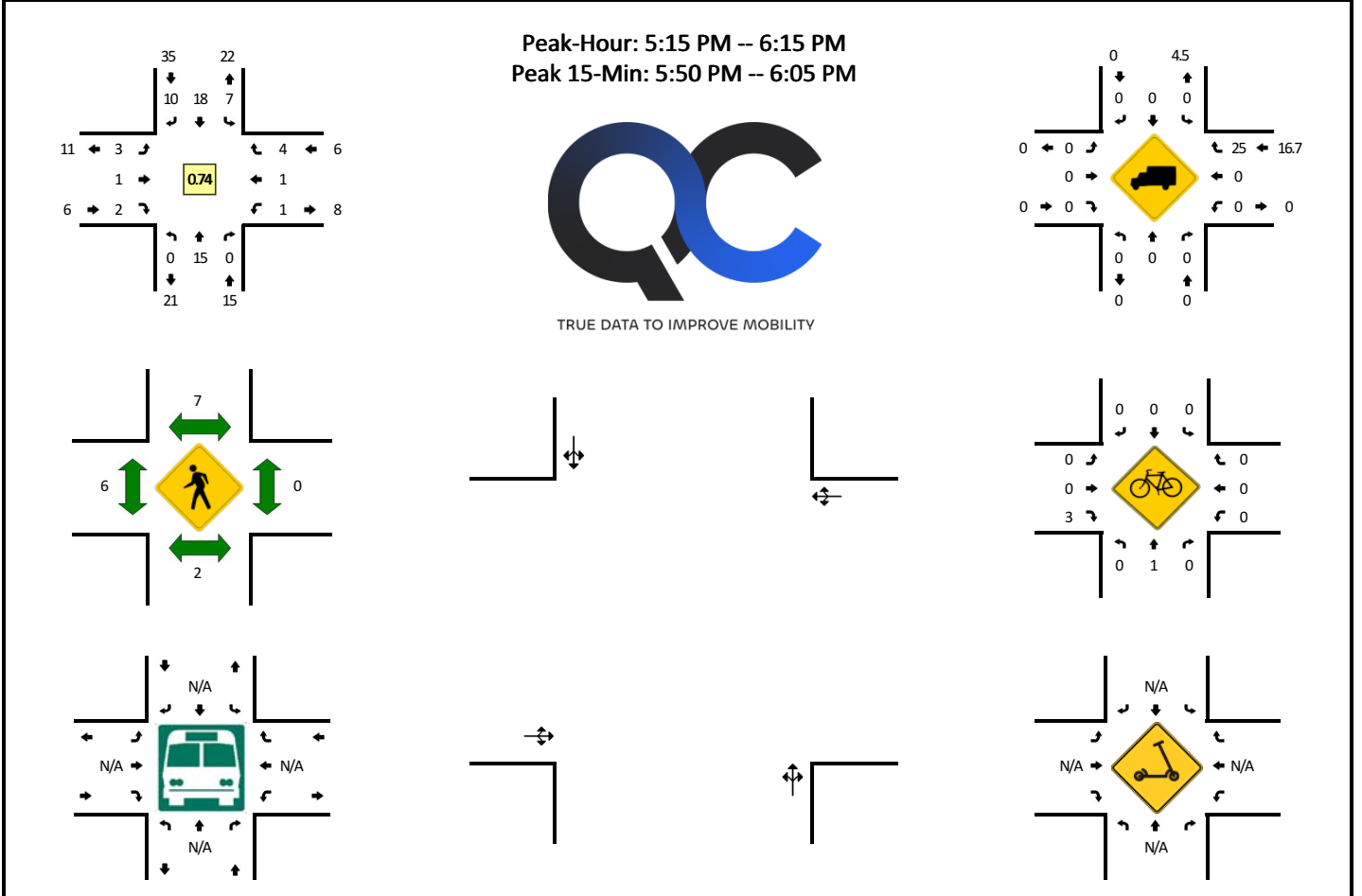

| 5-Min Count Period Beginning At | Chamberlain Ave (Northbound) |      |       |   | Chamberlain Ave (Southbound) |      |       |   | W Harle Ave (Eastbound) |      |       |   | W Harle Ave (Westbound) |      |       |   | Total | Hourly Totals |    |
|---------------------------------|------------------------------|------|-------|---|------------------------------|------|-------|---|-------------------------|------|-------|---|-------------------------|------|-------|---|-------|---------------|----|
|                                 | Left                         | Thru | Right | U | Left                         | Thru | Right | U | Left                    | Thru | Right | U | Left                    | Thru | Right | U |       |               |    |
| 6:00 AM                         | 0                            | 1    | 0     | 0 | 0                            | 1    | 0     | 0 | 0                       | 0    | 0     | 1 | 0                       | 0    | 0     | 0 | 0     | 3             |    |
| 6:05 AM                         | 0                            | 0    | 0     | 0 | 0                            | 0    | 0     | 0 | 0                       | 0    | 0     | 0 | 0                       | 0    | 0     | 0 | 0     | 0             |    |
| 6:10 AM                         | 0                            | 1    | 0     | 0 | 0                            | 0    | 0     | 0 | 0                       | 0    | 0     | 0 | 0                       | 0    | 0     | 0 | 0     | 1             |    |
| 6:15 AM                         | 0                            | 0    | 0     | 0 | 0                            | 0    | 1     | 0 | 0                       | 0    | 0     | 0 | 0                       | 0    | 0     | 0 | 0     | 1             |    |
| 6:20 AM                         | 0                            | 0    | 0     | 0 | 0                            | 0    | 1     | 0 | 0                       | 0    | 0     | 0 | 0                       | 0    | 0     | 0 | 0     | 1             |    |
| 6:25 AM                         | 0                            | 0    | 0     | 0 | 0                            | 0    | 0     | 0 | 0                       | 0    | 0     | 0 | 0                       | 0    | 0     | 0 | 0     | 0             |    |
| 6:30 AM                         | 0                            | 1    | 0     | 0 | 0                            | 1    | 0     | 0 | 0                       | 2    | 0     | 1 | 0                       | 0    | 0     | 0 | 0     | 5             |    |
| 6:35 AM                         | 0                            | 0    | 0     | 0 | 0                            | 0    | 0     | 0 | 0                       | 1    | 0     | 1 | 0                       | 0    | 0     | 0 | 0     | 2             |    |
| 6:40 AM                         | 0                            | 0    | 0     | 0 | 0                            | 0    | 0     | 0 | 0                       | 0    | 0     | 0 | 0                       | 0    | 0     | 0 | 0     | 0             |    |
| 6:45 AM                         | 0                            | 1    | 0     | 0 | 0                            | 2    | 0     | 0 | 0                       | 0    | 0     | 0 | 0                       | 0    | 0     | 0 | 0     | 3             |    |
| 6:50 AM                         | 0                            | 1    | 0     | 0 | 0                            | 1    | 0     | 0 | 0                       | 0    | 0     | 0 | 0                       | 0    | 0     | 0 | 0     | 2             |    |
| 6:55 AM                         | 0                            | 0    | 0     | 0 | 0                            | 0    | 0     | 0 | 0                       | 2    | 0     | 0 | 0                       | 0    | 1     | 0 | 0     | 3             | 21 |
| 7:00 AM                         | 0                            | 0    | 0     | 0 | 0                            | 1    | 0     | 0 | 0                       | 0    | 0     | 2 | 0                       | 0    | 0     | 0 | 0     | 3             | 21 |
| 7:05 AM                         | 0                            | 2    | 0     | 0 | 0                            | 1    | 0     | 0 | 0                       | 0    | 0     | 0 | 0                       | 0    | 0     | 0 | 0     | 3             | 24 |
| 7:10 AM                         | 0                            | 0    | 0     | 0 | 0                            | 1    | 0     | 0 | 0                       | 0    | 0     | 0 | 0                       | 0    | 0     | 0 | 0     | 1             | 24 |
| 7:15 AM                         | 0                            | 0    | 0     | 0 | 0                            | 1    | 0     | 0 | 0                       | 0    | 0     | 0 | 0                       | 0    | 0     | 0 | 0     | 1             | 24 |
| 7:20 AM                         | 1                            | 1    | 0     | 0 | 0                            | 2    | 0     | 0 | 0                       | 0    | 0     | 0 | 0                       | 0    | 0     | 0 | 0     | 4             | 27 |
| 7:25 AM                         | 0                            | 0    | 0     | 0 | 0                            | 2    | 0     | 0 | 0                       | 0    | 0     | 0 | 0                       | 0    | 0     | 0 | 0     | 2             | 29 |
| 7:30 AM                         | 0                            | 1    | 0     | 0 | 1                            | 1    | 0     | 0 | 0                       | 0    | 0     | 0 | 0                       | 0    | 0     | 1 | 0     | 4             | 28 |
| 7:35 AM                         | 0                            | 2    | 0     | 0 | 0                            | 4    | 0     | 0 | 0                       | 0    | 0     | 0 | 0                       | 0    | 0     | 1 | 0     | 7             | 33 |
| 7:40 AM                         | 0                            | 1    | 0     | 0 | 0                            | 2    | 1     | 0 | 0                       | 0    | 0     | 1 | 0                       | 0    | 0     | 0 | 0     | 5             | 38 |
| 7:45 AM                         | 0                            | 1    | 0     | 0 | 0                            | 1    | 0     | 0 | 0                       | 0    | 0     | 0 | 0                       | 0    | 0     | 0 | 0     | 2             | 37 |
| 7:50 AM                         | 0                            | 1    | 0     | 0 | 0                            | 2    | 0     | 0 | 0                       | 0    | 0     | 0 | 0                       | 0    | 0     | 0 | 0     | 3             | 38 |
| 7:55 AM                         | 0                            | 1    | 0     | 0 | 0                            | 3    | 0     | 0 | 0                       | 0    | 0     | 0 | 0                       | 0    | 0     | 0 | 0     | 4             | 39 |
| 8:00 AM                         | 1                            | 0    | 0     | 0 | 0                            | 2    | 0     | 0 | 0                       | 0    | 0     | 1 | 0                       | 0    | 0     | 1 | 0     | 5             | 41 |
| 8:05 AM                         | 0                            | 0    | 0     | 0 | 0                            | 0    | 0     | 0 | 0                       | 1    | 0     | 0 | 0                       | 0    | 0     | 0 | 0     | 1             | 39 |
| 8:10 AM                         | 0                            | 1    | 0     | 0 | 0                            | 1    | 0     | 0 | 0                       | 0    | 0     | 0 | 0                       | 0    | 1     | 0 | 0     | 3             | 41 |
| 8:15 AM                         | 1                            | 1    | 0     | 0 | 0                            | 0    | 0     | 0 | 0                       | 0    | 0     | 0 | 0                       | 0    | 0     | 0 | 0     | 2             | 42 |
| 8:20 AM                         | 0                            | 1    | 0     | 0 | 0                            | 1    | 0     | 0 | 0                       | 0    | 0     | 0 | 0                       | 0    | 0     | 0 | 0     | 2             | 40 |
| 8:25 AM                         | 0                            | 4    | 0     | 0 | 0                            | 1    | 0     | 0 | 0                       | 0    | 0     | 2 | 0                       | 0    | 1     | 0 | 0     | 8             | 46 |
| 8:30 AM                         | 0                            | 0    | 0     | 0 | 1                            | 3    | 0     | 0 | 0                       | 0    | 0     | 0 | 0                       | 1    | 0     | 0 | 0     | 5             | 47 |
| 8:35 AM                         | 0                            | 1    | 0     | 0 | 0                            | 3    | 0     | 0 | 0                       | 0    | 0     | 1 | 0                       | 0    | 0     | 0 | 0     | 4             | 44 |
| 8:40 AM                         | 0                            | 0    | 0     | 0 | 0                            | 0    | 0     | 0 | 0                       | 0    | 0     | 1 | 0                       | 0    | 0     | 0 | 0     | 1             | 40 |
| 8:45 AM                         | 0                            | 0    | 0     | 0 | 0                            | 1    | 0     | 0 | 0                       | 0    | 1     | 1 | 0                       | 0    | 0     | 0 | 0     | 3             | 41 |
| 8:50 AM                         | 0                            | 0    | 0     | 0 | 0                            | 2    | 0     | 0 | 0                       | 0    | 0     | 0 | 0                       | 0    | 0     | 0 | 0     | 2             | 40 |
| 8:55 AM                         | 0                            | 1    | 0     | 0 | 0                            | 0    | 0     | 0 | 0                       | 0    | 0     | 0 | 0                       | 0    | 0     | 0 | 0     | 1             | 37 |
| 9:00 AM                         | 0                            | 1    | 0     | 0 | 0                            | 1    | 0     | 0 | 0                       | 0    | 0     | 0 | 0                       | 0    | 0     | 0 | 0     | 2             | 34 |
| 9:05 AM                         | 0                            | 0    | 0     | 0 | 0                            | 0    | 0     | 0 | 0                       | 0    | 0     | 1 | 0                       | 0    | 0     | 0 | 0     | 1             | 34 |

Attachment B

| 5-Min Count Period Beginning At | Chamberlain Ave (Northbound) |      |       |   | Chamberlain Ave (Southbound) |      |       |   | W Harle Ave (Eastbound) |      |       |   | W Harle Ave (Westbound) |      |       |   | Total | Hourly Totals |
|---------------------------------|------------------------------|------|-------|---|------------------------------|------|-------|---|-------------------------|------|-------|---|-------------------------|------|-------|---|-------|---------------|
|                                 | Left                         | Thru | Right | U | Left                         | Thru | Right | U | Left                    | Thru | Right | U | Left                    | Thru | Right | U |       |               |
| 9:10 AM                         | 0                            | 2    | 0     | 0 | 0                            | 1    | 0     | 0 | 1                       | 0    | 1     | 0 | 0                       | 0    | 0     | 0 | 5     | 36            |
| 9:15 AM                         | 0                            | 1    | 0     | 0 | 0                            | 1    | 0     | 0 | 0                       | 0    | 0     | 0 | 0                       | 0    | 0     | 0 | 2     | 36            |
| 9:20 AM                         | 0                            | 0    | 0     | 0 | 0                            | 0    | 0     | 0 | 0                       | 0    | 0     | 0 | 0                       | 0    | 0     | 0 | 0     | 34            |
| 9:25 AM                         | 0                            | 0    | 0     | 0 | 0                            | 1    | 0     | 0 | 0                       | 0    | 0     | 0 | 0                       | 0    | 0     | 0 | 1     | 27            |
| 9:30 AM                         | 0                            | 0    | 0     | 0 | 1                            | 0    | 1     | 0 | 0                       | 0    | 1     | 0 | 0                       | 0    | 1     | 0 | 4     | 26            |
| 9:35 AM                         | 0                            | 2    | 0     | 0 | 0                            | 0    | 0     | 0 | 0                       | 1    | 0     | 0 | 0                       | 0    | 1     | 0 | 4     | 26            |
| 9:40 AM                         | 0                            | 0    | 0     | 0 | 0                            | 1    | 0     | 0 | 0                       | 0    | 0     | 0 | 0                       | 0    | 0     | 0 | 1     | 26            |
| 9:45 AM                         | 0                            | 0    | 0     | 0 | 0                            | 0    | 0     | 0 | 1                       | 0    | 0     | 0 | 0                       | 0    | 0     | 0 | 1     | 24            |
| 9:50 AM                         | 0                            | 1    | 0     | 0 | 0                            | 1    | 0     | 0 | 0                       | 0    | 0     | 0 | 0                       | 0    | 0     | 0 | 2     | 24            |
| 9:55 AM                         | 0                            | 0    | 0     | 0 | 1                            | 0    | 0     | 0 | 0                       | 0    | 0     | 0 | 0                       | 0    | 0     | 0 | 1     | 24            |
| 10:00 AM                        | 0                            | 0    | 0     | 0 | 0                            | 0    | 0     | 0 | 1                       | 0    | 0     | 0 | 1                       | 0    | 0     | 0 | 2     | 24            |
| 10:05 AM                        | 0                            | 3    | 0     | 0 | 0                            | 0    | 0     | 0 | 0                       | 0    | 0     | 0 | 0                       | 0    | 0     | 0 | 3     | 26            |
| 10:10 AM                        | 0                            | 0    | 0     | 0 | 2                            | 0    | 1     | 0 | 1                       | 0    | 0     | 0 | 0                       | 0    | 1     | 0 | 5     | 26            |
| 10:15 AM                        | 0                            | 0    | 1     | 0 | 0                            | 0    | 0     | 0 | 0                       | 0    | 0     | 0 | 0                       | 0    | 0     | 0 | 1     | 25            |
| 10:20 AM                        | 0                            | 1    | 0     | 0 | 0                            | 0    | 0     | 0 | 0                       | 0    | 0     | 0 | 0                       | 0    | 0     | 0 | 1     | 26            |
| 10:25 AM                        | 0                            | 0    | 0     | 0 | 0                            | 0    | 0     | 0 | 1                       | 0    | 0     | 0 | 0                       | 0    | 0     | 0 | 1     | 26            |
| 10:30 AM                        | 0                            | 0    | 0     | 0 | 0                            | 0    | 0     | 0 | 0                       | 0    | 0     | 0 | 0                       | 0    | 1     | 0 | 1     | 23            |
| 10:35 AM                        | 0                            | 0    | 0     | 0 | 0                            | 0    | 0     | 0 | 0                       | 0    | 0     | 0 | 0                       | 0    | 0     | 0 | 0     | 19            |
| 10:40 AM                        | 0                            | 1    | 0     | 0 | 0                            | 0    | 0     | 0 | 0                       | 0    | 0     | 0 | 0                       | 0    | 0     | 0 | 1     | 19            |
| 10:45 AM                        | 0                            | 1    | 0     | 0 | 0                            | 2    | 0     | 0 | 2                       | 0    | 1     | 0 | 0                       | 0    | 0     | 0 | 6     | 24            |
| 10:50 AM                        | 0                            | 0    | 0     | 0 | 0                            | 1    | 0     | 0 | 0                       | 0    | 0     | 0 | 0                       | 0    | 2     | 0 | 3     | 25            |
| 10:55 AM                        | 0                            | 1    | 0     | 0 | 0                            | 1    | 0     | 0 | 0                       | 0    | 0     | 0 | 0                       | 0    | 0     | 0 | 2     | 26            |
| 11:00 AM                        | 0                            | 0    | 0     | 0 | 0                            | 1    | 1     | 0 | 0                       | 0    | 0     | 0 | 0                       | 0    | 0     | 0 | 2     | 26            |
| 11:05 AM                        | 1                            | 1    | 0     | 0 | 0                            | 1    | 2     | 0 | 0                       | 0    | 0     | 0 | 0                       | 0    | 0     | 0 | 5     | 28            |
| 11:10 AM                        | 0                            | 1    | 0     | 0 | 0                            | 1    | 0     | 0 | 0                       | 0    | 0     | 0 | 0                       | 0    | 0     | 0 | 2     | 25            |
| 11:15 AM                        | 0                            | 0    | 0     | 0 | 0                            | 1    | 1     | 0 | 0                       | 0    | 0     | 0 | 0                       | 0    | 0     | 0 | 2     | 26            |
| 11:20 AM                        | 0                            | 1    | 0     | 0 | 0                            | 1    | 0     | 0 | 0                       | 0    | 0     | 0 | 0                       | 0    | 0     | 0 | 2     | 27            |
| 11:25 AM                        | 0                            | 0    | 0     | 0 | 0                            | 0    | 0     | 0 | 0                       | 0    | 0     | 0 | 0                       | 0    | 0     | 0 | 0     | 26            |
| 11:30 AM                        | 0                            | 0    | 0     | 0 | 0                            | 1    | 0     | 0 | 0                       | 0    | 0     | 0 | 0                       | 0    | 0     | 0 | 1     | 26            |
| 11:35 AM                        | 0                            | 1    | 0     | 0 | 0                            | 1    | 0     | 0 | 0                       | 0    | 1     | 0 | 0                       | 0    | 1     | 0 | 4     | 30            |
| 11:40 AM                        | 0                            | 0    | 0     | 0 | 2                            | 0    | 0     | 0 | 0                       | 0    | 0     | 0 | 0                       | 0    | 0     | 0 | 2     | 31            |
| 11:45 AM                        | 0                            | 0    | 0     | 0 | 0                            | 1    | 0     | 0 | 0                       | 0    | 1     | 0 | 0                       | 0    | 0     | 0 | 2     | 27            |
| 11:50 AM                        | 0                            | 1    | 0     | 0 | 1                            | 0    | 0     | 0 | 0                       | 0    | 0     | 0 | 0                       | 0    | 0     | 0 | 2     | 26            |
| 11:55 AM                        | 1                            | 0    | 0     | 0 | 0                            | 0    | 0     | 0 | 1                       | 0    | 0     | 0 | 0                       | 0    | 0     | 0 | 2     | 26            |
| 12:00 PM                        | 0                            | 0    | 0     | 0 | 0                            | 2    | 0     | 0 | 0                       | 0    | 0     | 0 | 0                       | 0    | 0     | 0 | 2     | 26            |
| 12:05 PM                        | 0                            | 0    | 0     | 0 | 1                            | 1    | 1     | 0 | 1                       | 0    | 1     | 0 | 0                       | 0    | 0     | 0 | 5     | 26            |
| 12:10 PM                        | 0                            | 2    | 0     | 0 | 0                            | 1    | 0     | 0 | 0                       | 2    | 1     | 0 | 1                       | 0    | 0     | 0 | 7     | 31            |
| 12:15 PM                        | 0                            | 0    | 0     | 0 | 0                            | 1    | 0     | 0 | 0                       | 0    | 1     | 0 | 0                       | 0    | 0     | 0 | 2     | 31            |
| 12:20 PM                        | 0                            | 0    | 0     | 0 | 0                            | 0    | 0     | 0 | 0                       | 0    | 0     | 0 | 0                       | 0    | 0     | 0 | 0     | 29            |
| 12:25 PM                        | 1                            | 0    | 0     | 0 | 0                            | 1    | 1     | 0 | 0                       | 0    | 0     | 0 | 1                       | 0    | 0     | 0 | 4     | 33            |
| 12:30 PM                        | 0                            | 0    | 0     | 0 | 0                            | 0    | 0     | 0 | 0                       | 0    | 0     | 0 | 0                       | 0    | 1     | 0 | 1     | 33            |
| 12:35 PM                        | 0                            | 1    | 0     | 0 | 0                            | 2    | 0     | 0 | 0                       | 0    | 0     | 0 | 0                       | 0    | 0     | 0 | 3     | 32            |
| 12:40 PM                        | 0                            | 0    | 0     | 0 | 0                            | 1    | 0     | 0 | 3                       | 0    | 0     | 0 | 0                       | 0    | 0     | 0 | 4     | 34            |
| 12:45 PM                        | 0                            | 0    | 1     | 0 | 0                            | 1    | 0     | 0 | 0                       | 0    | 0     | 0 | 0                       | 0    | 1     | 0 | 3     | 35            |
| 12:50 PM                        | 0                            | 1    | 0     | 0 | 0                            | 3    | 2     | 0 | 0                       | 0    | 0     | 0 | 0                       | 0    | 0     | 0 | 6     | 39            |
| 12:55 PM                        | 0                            | 1    | 0     | 0 | 0                            | 1    | 0     | 0 | 0                       | 0    | 0     | 0 | 1                       | 0    | 0     | 0 | 3     | 40            |
| 1:00 PM                         | 1                            | 0    | 0     | 0 | 1                            | 1    | 1     | 0 | 0                       | 0    | 0     | 0 | 0                       | 1    | 0     | 0 | 5     | 43            |
| 1:05 PM                         | 0                            | 0    | 0     | 0 | 0                            | 2    | 0     | 0 | 0                       | 0    | 0     | 0 | 0                       | 0    | 1     | 0 | 3     | 41            |
| 1:10 PM                         | 0                            | 1    | 0     | 0 | 0                            | 0    | 0     | 0 | 0                       | 0    | 1     | 0 | 0                       | 0    | 0     | 0 | 2     | 36            |
| 1:15 PM                         | 0                            | 0    | 0     | 0 | 0                            | 1    | 0     | 0 | 1                       | 0    | 0     | 0 | 0                       | 0    | 0     | 0 | 2     | 36            |
| 1:20 PM                         | 0                            | 0    | 0     | 0 | 1                            | 0    | 0     | 0 | 0                       | 0    | 0     | 0 | 0                       | 0    | 0     | 0 | 1     | 37            |
| 1:25 PM                         | 0                            | 0    | 0     | 0 | 0                            | 1    | 0     | 0 | 0                       | 0    | 0     | 0 | 0                       | 0    | 0     | 0 | 1     | 34            |
| 1:30 PM                         | 1                            | 2    | 0     | 0 | 1                            | 3    | 1     | 0 | 0                       | 0    | 0     | 0 | 0                       | 0    | 0     | 0 | 8     | 41            |
| 1:35 PM                         | 0                            | 0    | 0     | 0 | 0                            | 0    | 0     | 0 | 0                       | 0    | 0     | 0 | 0                       | 0    | 0     | 0 | 0     | 38            |
| 1:40 PM                         | 0                            | 0    | 0     | 0 | 1                            | 0    | 0     | 0 | 0                       | 0    | 1     | 0 | 0                       | 0    | 0     | 0 | 2     | 36            |
| 1:45 PM                         | 0                            | 1    | 0     | 0 | 0                            | 0    | 0     | 0 | 0                       | 0    | 0     | 0 | 0                       | 0    | 0     | 0 | 1     | 34            |
| 1:50 PM                         | 0                            | 1    | 0     | 0 | 1                            | 1    | 0     | 0 | 0                       | 0    | 0     | 0 | 0                       | 1    | 0     | 0 | 4     | 32            |
| 1:55 PM                         | 0                            | 0    | 0     | 0 | 0                            | 1    | 0     | 0 | 0                       | 0    | 0     | 0 | 1                       | 0    | 0     | 0 | 2     | 31            |
| 2:00 PM                         | 0                            | 0    | 0     | 0 | 0                            | 0    | 0     | 0 | 0                       | 0    | 1     | 0 | 0                       | 0    | 0     | 0 | 1     | 27            |
| 2:05 PM                         | 0                            | 1    | 0     | 0 | 0                            | 1    | 0     | 0 | 0                       | 0    | 1     | 0 | 1                       | 0    | 1     | 0 | 5     | 29            |
| 2:10 PM                         | 0                            | 2    | 0     | 0 | 0                            | 1    | 0     | 0 | 0                       | 0    | 0     | 0 | 0                       | 0    | 0     | 0 | 3     | 30            |
| 2:15 PM                         | 0                            | 1    | 0     | 0 | 0                            | 0    | 1     | 0 | 0                       | 0    | 0     | 0 | 0                       | 0    | 0     | 0 | 2     | 30            |
| 2:20 PM                         | 0                            | 2    | 0     | 0 | 0                            | 2    | 0     | 0 | 0                       | 0    | 0     | 0 | 0                       | 0    | 0     | 0 | 4     | 33            |
| 2:25 PM                         | 0                            | 1    | 0     | 0 | 0                            | 0    | 0     | 0 | 0                       | 1    | 0     | 0 | 0                       | 0    | 0     | 0 | 2     | 34            |
| 2:30 PM                         | 0                            | 1    | 0     | 0 | 0                            | 1    | 0     | 0 | 0                       | 0    | 0     | 0 | 0                       | 0    | 0     | 0 | 2     | 28            |
| 2:35 PM                         | 0                            | 0    | 0     | 0 | 0                            | 2    | 0     | 0 | 0                       | 0    | 0     | 0 | 0                       | 0    | 0     | 0 | 2     | 30            |
| 2:40 PM                         | 0                            | 0    | 0     | 0 | 0                            | 2    | 0     | 0 | 0                       | 0    | 0     | 0 | 0                       | 0    | 0     | 0 | 2     | 30            |
| 2:45 PM                         | 1                            | 1    | 0     | 0 | 0                            | 1    | 0     | 0 | 0                       | 0    | 0     | 0 | 0                       | 0    | 0     | 0 | 3     | 32            |
| 2:50 PM                         | 1                            | 1    | 0     | 0 | 0                            | 0    | 0     | 0 | 0                       | 0    | 1     | 0 | 0                       | 0    | 1     | 0 | 4     | 32            |
| 2:55 PM                         | 0                            | 0    | 0     | 0 | 0                            | 3    | 0     | 0 | 0                       | 0    | 1     | 0 | 0                       | 0    | 0     | 0 | 4     | 34            |
| 3:00 PM                         | 0                            | 0    | 0     | 0 | 0                            | 3    | 1     | 0 | 0                       | 0    | 0     | 0 | 0                       | 0    | 0     | 0 | 4     | 37            |
| 3:05 PM                         | 0                            | 1    | 0     | 0 | 0                            | 2    | 1     | 0 | 0                       | 0    | 1     | 0 | 0                       | 0    | 0     | 0 | 5     | 37            |
| 3:10 PM                         | 0                            | 0    | 0     | 0 | 0                            | 2    | 1     | 0 | 0                       | 0    | 0     | 0 | 0                       | 0    | 0     | 0 | 3     | 37            |
| 3:15 PM                         | 0                            | 0    | 0     | 0 | 0                            | 1    | 1     | 0 | 0                       | 1    | 1     | 0 | 1                       | 0    | 0     | 0 | 5     | 40            |
| 3:20 PM                         | 0                            | 1    | 1     | 0 | 0                            | 2    | 1     | 0 | 1                       | 0    | 0     | 0 | 0                       | 0    | 1     | 0 | 7     | 43            |
| 3:25 PM                         | 0                            | 4    | 0     | 0 | 2                            | 0    | 1     | 0 | 0                       | 0    | 0     | 0 | 0                       | 0    | 0     | 0 | 7     | 48            |
| 3:30 PM                         | 0                            | 0    | 0     | 0 | 1                            | 3    | 2     | 0 | 0                       | 0    | 0     | 0 | 0                       | 1    | 0     | 0 | 7     | 53            |
| 3:35 PM                         | 0                            | 0    | 0     | 0 | 0                            | 2    | 0     | 0 | 0                       | 0    | 1     | 0 | 0                       | 0    | 0     | 0 | 3     | 54            |
| 3:40 PM                         | 0                            | 0    | 0     | 0 | 0                            | 3    | 2     | 0 | 0                       | 0    | 0     | 0 | 0                       | 0    | 0     | 0 | 5     | 57            |
| 3:45 PM                         | 0                            | 0    | 0     | 0 | 0                            | 1    | 0     | 0 | 0                       | 0    | 0     | 0 | 0                       | 0    | 0     | 0 | 1     | 55            |
| 3:50 PM                         | 0                            | 1    | 0     | 0 | 1                            | 2    | 0     | 0 | 0                       | 0    | 0     | 0 | 0                       | 0    | 0     | 0 | 4     | 55            |
| 3:55 PM                         | 0                            | 0    | 0     | 0 | 0                            | 1    | 0     | 0 | 0                       | 0    | 0     | 0 | 0                       | 0    | 1     | 0 | 2     | 53            |
| 4:00 PM                         | 0                            | 1    | 0     | 0 | 1                            | 3    | 0     | 0 | 0                       | 1    | 0     | 0 | 0                       | 0    | 0     | 0 | 6     | 55            |
| 4:05 PM                         | 0                            | 1    | 0     | 0 | 1                            | 1    | 1     | 0 | 0                       | 0    | 1     | 0 | 0                       | 0    | 0     | 0 | 5     | 55            |
| 4:10 PM                         | 0                            | 1    | 0     | 0 | 0                            | 2    | 2     | 0 | 1                       | 0    | 0     | 0 | 0                       | 0    | 0     | 0 | 6     | 58            |
| 4:15 PM                         | 0                            | 0    | 0     | 0 | 0                            | 2    | 0     | 0 | 1                       | 0    | 0     | 0 | 0                       | 0    | 0     | 0 | 3     | 56            |
| 4:20 PM                         | 0                            | 0    | 0     | 0 | 1                            | 0    | 1     | 0 | 1                       | 0    | 0     | 0 | 0                       | 1    | 0     | 0 | 4     | 53            |
| 4:25 PM                         | 0                            | 0    | 0     | 0 | 0                            | 2    | 0     | 0 | 0                       | 0    | 0     | 0 | 0                       | 0    | 0     | 0 | 2     | 48            |
| 4:30 PM                         | 0                            | 1    | 0     | 0 | 0                            | 2    | 0     | 0 | 0                       | 0    | 1     | 0 | 0                       | 0    | 0     | 0 | 4     | 45            |

## Attachment B

| 5-Min Count Period Beginning At | Chamberlain Ave (Northbound) |      |       |   | Chamberlain Ave (Southbound) |      |       |   | W Harle Ave (Eastbound) |      |       |   | W Harle Ave (Westbound) |      |       |   | Total | Hourly Totals |
|---------------------------------|------------------------------|------|-------|---|------------------------------|------|-------|---|-------------------------|------|-------|---|-------------------------|------|-------|---|-------|---------------|
|                                 | Left                         | Thru | Right | U | Left                         | Thru | Right | U | Left                    | Thru | Right | U | Left                    | Thru | Right | U |       |               |
| 4:35 PM                         | 0                            | 1    | 0     | 0 | 0                            | 2    | 1     | 0 | 0                       | 0    | 1     | 0 | 0                       | 0    | 0     | 0 | 5     | 47            |
| 4:40 PM                         | 0                            | 1    | 1     | 0 | 0                            | 2    | 0     | 0 | 0                       | 0    | 0     | 0 | 0                       | 0    | 0     | 0 | 4     | 46            |
| 4:45 PM                         | 0                            | 1    | 0     | 0 | 0                            | 0    | 1     | 0 | 0                       | 0    | 0     | 0 | 0                       | 0    | 1     | 0 | 3     | 48            |
| 4:50 PM                         | 1                            | 2    | 0     | 0 | 0                            | 2    | 2     | 0 | 0                       | 0    | 0     | 0 | 0                       | 1    | 0     | 0 | 8     | 52            |
| 4:55 PM                         | 0                            | 0    | 0     | 0 | 0                            | 1    | 1     | 0 | 0                       | 0    | 0     | 0 | 0                       | 0    | 0     | 0 | 2     | 52            |
| 5:00 PM                         | 0                            | 0    | 0     | 0 | 0                            | 0    | 0     | 0 | 0                       | 0    | 0     | 0 | 0                       | 1    | 0     | 0 | 1     | 47            |
| 5:05 PM                         | 0                            | 2    | 0     | 0 | 1                            | 1    | 0     | 0 | 0                       | 0    | 0     | 0 | 0                       | 0    | 1     | 0 | 5     | 47            |
| 5:10 PM                         | 0                            | 0    | 0     | 0 | 0                            | 0    | 0     | 0 | 0                       | 0    | 0     | 0 | 0                       | 0    | 1     | 0 | 1     | 42            |
| 5:15 PM                         | 0                            | 3    | 0     | 0 | 1                            | 2    | 2     | 0 | 1                       | 1    | 0     | 0 | 0                       | 0    | 1     | 0 | 11    | 50            |
| 5:20 PM                         | 0                            | 0    | 0     | 0 | 0                            | 1    | 1     | 0 | 0                       | 0    | 0     | 0 | 0                       | 0    | 0     | 0 | 2     | 48            |
| 5:25 PM                         | 0                            | 2    | 0     | 0 | 0                            | 0    | 2     | 0 | 0                       | 0    | 0     | 0 | 0                       | 1    | 1     | 0 | 6     | 52            |
| 5:30 PM                         | 0                            | 1    | 0     | 0 | 1                            | 2    | 0     | 0 | 0                       | 0    | 0     | 0 | 0                       | 0    | 0     | 0 | 4     | 52            |
| 5:35 PM                         | 0                            | 1    | 0     | 0 | 2                            | 2    | 0     | 0 | 0                       | 0    | 0     | 0 | 1                       | 0    | 1     | 0 | 7     | 54            |
| 5:40 PM                         | 0                            | 0    | 0     | 0 | 0                            | 1    | 0     | 0 | 0                       | 0    | 0     | 0 | 0                       | 0    | 0     | 0 | 1     | 51            |
| 5:45 PM                         | 0                            | 1    | 0     | 0 | 0                            | 0    | 0     | 0 | 0                       | 0    | 1     | 0 | 0                       | 0    | 0     | 0 | 2     | 50            |
| 5:50 PM                         | 0                            | 4    | 0     | 0 | 0                            | 1    | 0     | 0 | 1                       | 0    | 0     | 0 | 0                       | 0    | 0     | 0 | 6     | 48            |
| 5:55 PM                         | 0                            | 1    | 0     | 0 | 1                            | 2    | 1     | 0 | 0                       | 0    | 1     | 0 | 0                       | 0    | 1     | 0 | 7     | 53            |
| 6:00 PM                         | 0                            | 1    | 0     | 0 | 1                            | 3    | 2     | 0 | 1                       | 0    | 0     | 0 | 0                       | 0    | 0     | 0 | 8     | 60            |
| 6:05 PM                         | 0                            | 1    | 0     | 0 | 1                            | 2    | 1     | 0 | 0                       | 0    | 0     | 0 | 0                       | 0    | 0     | 0 | 5     | 60            |
| 6:10 PM                         | 0                            | 0    | 0     | 0 | 0                            | 2    | 1     | 0 | 0                       | 0    | 0     | 0 | 0                       | 0    | 0     | 0 | 3     | 62            |
| 6:15 PM                         | 0                            | 1    | 0     | 0 | 0                            | 1    | 1     | 0 | 1                       | 0    | 0     | 0 | 0                       | 0    | 0     | 0 | 4     | 55            |
| 6:20 PM                         | 0                            | 0    | 0     | 0 | 0                            | 1    | 0     | 0 | 1                       | 0    | 2     | 0 | 0                       | 0    | 1     | 0 | 5     | 58            |
| 6:25 PM                         | 0                            | 1    | 0     | 0 | 0                            | 2    | 1     | 0 | 0                       | 1    | 0     | 0 | 1                       | 0    | 0     | 0 | 6     | 58            |
| 6:30 PM                         | 0                            | 0    | 0     | 0 | 1                            | 0    | 1     | 0 | 0                       | 0    | 0     | 0 | 1                       | 0    | 0     | 0 | 3     | 57            |
| 6:35 PM                         | 0                            | 1    | 0     | 0 | 1                            | 2    | 0     | 0 | 0                       | 0    | 0     | 0 | 0                       | 0    | 2     | 0 | 6     | 56            |
| 6:40 PM                         | 0                            | 1    | 0     | 0 | 0                            | 1    | 0     | 0 | 0                       | 0    | 0     | 0 | 0                       | 1    | 1     | 0 | 4     | 59            |
| 6:45 PM                         | 0                            | 1    | 0     | 0 | 0                            | 1    | 1     | 0 | 0                       | 0    | 0     | 0 | 1                       | 0    | 0     | 0 | 4     | 61            |
| 6:50 PM                         | 0                            | 0    | 1     | 0 | 0                            | 2    | 0     | 0 | 1                       | 0    | 0     | 0 | 0                       | 0    | 0     | 0 | 4     | 59            |
| 6:55 PM                         | 0                            | 0    | 0     | 0 | 0                            | 0    | 0     | 0 | 1                       | 0    | 0     | 0 | 0                       | 0    | 0     | 0 | 1     | 53            |
| 7:00 PM                         | 0                            | 1    | 0     | 0 | 0                            | 2    | 1     | 0 | 0                       | 0    | 0     | 0 | 0                       | 0    | 0     | 0 | 4     | 49            |
| 7:05 PM                         | 0                            | 1    | 0     | 0 | 0                            | 0    | 0     | 0 | 1                       | 1    | 0     | 0 | 0                       | 0    | 0     | 0 | 3     | 47            |
| 7:10 PM                         | 0                            | 1    | 1     | 0 | 0                            | 1    | 0     | 0 | 1                       | 0    | 0     | 0 | 0                       | 1    | 1     | 0 | 6     | 50            |
| 7:15 PM                         | 0                            | 1    | 0     | 0 | 1                            | 2    | 3     | 0 | 0                       | 0    | 0     | 0 | 0                       | 0    | 0     | 0 | 7     | 53            |
| 7:20 PM                         | 0                            | 0    | 0     | 0 | 0                            | 1    | 0     | 0 | 2                       | 0    | 0     | 0 | 0                       | 0    | 0     | 0 | 3     | 51            |
| 7:25 PM                         | 0                            | 0    | 0     | 0 | 0                            | 2    | 0     | 0 | 0                       | 0    | 0     | 0 | 0                       | 0    | 0     | 0 | 2     | 47            |
| 7:30 PM                         | 0                            | 0    | 0     | 0 | 0                            | 0    | 0     | 0 | 0                       | 1    | 0     | 0 | 0                       | 0    | 1     | 0 | 2     | 46            |
| 7:35 PM                         | 1                            | 1    | 0     | 0 | 0                            | 2    | 0     | 0 | 0                       | 0    | 0     | 0 | 0                       | 0    | 1     | 0 | 5     | 45            |
| 7:40 PM                         | 0                            | 1    | 0     | 0 | 0                            | 1    | 1     | 0 | 0                       | 0    | 0     | 0 | 0                       | 0    | 0     | 0 | 3     | 44            |
| 7:45 PM                         | 0                            | 1    | 0     | 0 | 0                            | 0    | 1     | 0 | 0                       | 0    | 0     | 0 | 0                       | 0    | 0     | 0 | 2     | 42            |
| 7:50 PM                         | 0                            | 0    | 0     | 0 | 0                            | 0    | 0     | 0 | 0                       | 0    | 0     | 0 | 0                       | 0    | 0     | 0 | 0     | 38            |
| 7:55 PM                         | 0                            | 2    | 0     | 0 | 0                            | 0    | 1     | 0 | 1                       | 0    | 1     | 0 | 0                       | 0    | 0     | 0 | 5     | 42            |
| 8:00 PM                         | 0                            | 2    | 0     | 0 | 0                            | 1    | 1     | 0 | 0                       | 0    | 0     | 0 | 0                       | 0    | 0     | 0 | 4     | 42            |
| 8:05 PM                         | 0                            | 0    | 0     | 0 | 1                            | 1    | 0     | 0 | 1                       | 0    | 0     | 0 | 0                       | 0    | 0     | 0 | 3     | 42            |
| 8:10 PM                         | 0                            | 0    | 0     | 0 | 0                            | 0    | 1     | 0 | 1                       | 0    | 0     | 0 | 0                       | 0    | 0     | 0 | 2     | 38            |
| 8:15 PM                         | 0                            | 0    | 0     | 0 | 0                            | 2    | 0     | 0 | 0                       | 0    | 0     | 0 | 0                       | 0    | 0     | 0 | 2     | 33            |
| 8:20 PM                         | 0                            | 3    | 0     | 0 | 0                            | 2    | 0     | 0 | 0                       | 0    | 0     | 0 | 0                       | 0    | 0     | 0 | 5     | 35            |
| 8:25 PM                         | 0                            | 0    | 0     | 0 | 0                            | 0    | 0     | 0 | 0                       | 0    | 1     | 0 | 0                       | 0    | 0     | 0 | 1     | 34            |
| 8:30 PM                         | 0                            | 0    | 0     | 0 | 0                            | 1    | 1     | 0 | 0                       | 0    | 0     | 0 | 0                       | 0    | 0     | 0 | 2     | 34            |
| 8:35 PM                         | 0                            | 2    | 0     | 0 | 3                            | 1    | 0     | 0 | 1                       | 0    | 0     | 0 | 0                       | 0    | 0     | 0 | 7     | 36            |
| 8:40 PM                         | 0                            | 0    | 0     | 0 | 0                            | 0    | 1     | 0 | 1                       | 0    | 1     | 0 | 0                       | 0    | 1     | 0 | 4     | 37            |
| 8:45 PM                         | 0                            | 0    | 0     | 0 | 0                            | 1    | 0     | 0 | 0                       | 0    | 0     | 0 | 0                       | 0    | 0     | 0 | 1     | 36            |
| 8:50 PM                         | 0                            | 1    | 0     | 0 | 0                            | 0    | 0     | 0 | 0                       | 0    | 0     | 0 | 0                       | 0    | 0     | 0 | 1     | 37            |
| 8:55 PM                         | 0                            | 1    | 0     | 0 | 1                            | 0    | 1     | 0 | 0                       | 0    | 0     | 0 | 0                       | 0    | 0     | 0 | 3     | 35            |
| 9:00 PM                         | 0                            | 0    | 0     | 0 | 0                            | 0    | 1     | 0 | 0                       | 0    | 0     | 0 | 0                       | 0    | 0     | 0 | 1     | 32            |
| 9:05 PM                         | 0                            | 0    | 0     | 0 | 1                            | 0    | 0     | 0 | 0                       | 0    | 0     | 0 | 0                       | 0    | 0     | 0 | 1     | 30            |
| 9:10 PM                         | 0                            | 0    | 0     | 0 | 0                            | 0    | 0     | 0 | 0                       | 0    | 1     | 0 | 0                       | 0    | 2     | 0 | 3     | 31            |
| 9:15 PM                         | 0                            | 0    | 0     | 0 | 0                            | 1    | 0     | 0 | 0                       | 1    | 0     | 0 | 0                       | 0    | 0     | 0 | 2     | 31            |
| 9:20 PM                         | 0                            | 0    | 0     | 0 | 0                            | 1    | 0     | 0 | 0                       | 0    | 0     | 0 | 0                       | 0    | 0     | 0 | 1     | 27            |
| 9:25 PM                         | 0                            | 0    | 0     | 0 | 0                            | 1    | 1     | 0 | 0                       | 0    | 0     | 0 | 0                       | 0    | 0     | 0 | 2     | 28            |
| 9:30 PM                         | 0                            | 0    | 0     | 0 | 0                            | 0    | 0     | 0 | 0                       | 0    | 0     | 0 | 0                       | 0    | 0     | 0 | 0     | 26            |
| 9:35 PM                         | 0                            | 1    | 0     | 0 | 0                            | 0    | 1     | 0 | 0                       | 0    | 0     | 0 | 0                       | 0    | 0     | 0 | 2     | 21            |
| 9:40 PM                         | 0                            | 0    | 0     | 0 | 1                            | 0    | 0     | 0 | 0                       | 0    | 0     | 0 | 0                       | 0    | 0     | 0 | 1     | 18            |
| 9:45 PM                         | 0                            | 0    | 0     | 0 | 1                            | 0    | 0     | 0 | 0                       | 0    | 0     | 0 | 0                       | 0    | 0     | 0 | 1     | 18            |
| 9:50 PM                         | 0                            | 0    | 0     | 0 | 0                            | 1    | 1     | 0 | 2                       | 0    | 0     | 0 | 0                       | 0    | 0     | 0 | 4     | 21            |
| 9:55 PM                         | 0                            | 0    | 0     | 0 | 0                            | 2    | 0     | 0 | 0                       | 0    | 0     | 0 | 0                       | 0    | 0     | 0 | 2     | 20            |
| Peak 15-Min Flowrates           | Northbound                   |      |       |   | Southbound                   |      |       |   | Eastbound               |      |       |   | Westbound               |      |       |   | Total |               |
|                                 | Left                         | Thru | Right | U | Left                         | Thru | Right | U | Left                    | Thru | Right | U | Left                    | Thru | Right | U |       |               |
| All Vehicles                    | 0                            | 24   | 0     | 0 | 8                            | 24   | 12    | 0 | 8                       | 0    | 4     | 0 | 0                       | 0    | 4     | 0 | 84    |               |
| Heavy Trucks                    | 0                            | 0    | 0     | 0 | 0                            | 0    | 0     | 0 | 0                       | 0    | 0     | 0 | 0                       | 0    | 4     | 0 | 4     |               |
| Buses                           |                              |      |       |   |                              |      |       |   |                         |      |       |   |                         |      |       |   |       |               |
| Pedestrians                     |                              | 0    |       |   |                              | 4    |       |   |                         | 0    |       |   |                         | 0    |       |   | 4     |               |
| Bicycles                        | 0                            | 0    | 0     |   | 0                            | 0    | 0     |   | 0                       | 0    | 0     |   | 0                       | 0    | 0     |   | 0     |               |
| Scoters                         |                              |      |       |   |                              |      |       |   |                         |      |       |   |                         |      |       |   |       |               |

Comments:

Type of peak hour being reported: Intersection Peak

Method for determining peak hour: Total Entering Volume

LOCATION: D' Este Dr -- Guinida Ln  
 CITY/STATE: Orange, CA

QC JOB #: 16966427  
 DATE: Wed, Apr 9 2025

Peak-Hour: 7:35 AM -- 8:35 AM  
 Peak 15-Min: 8:20 AM -- 8:35 AM

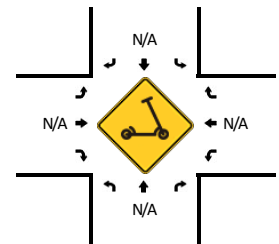
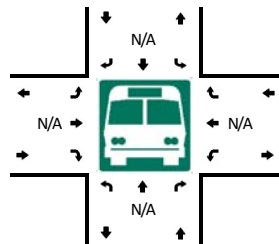
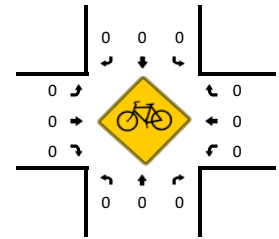
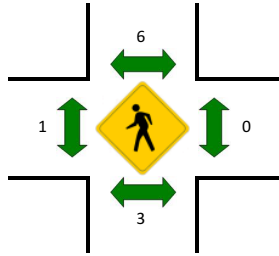
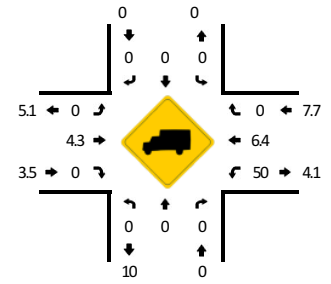
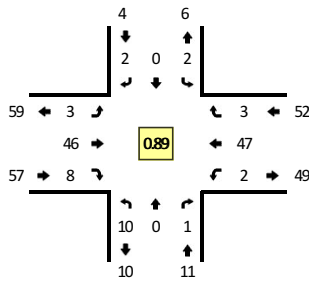

| 5-Min Count Period Beginning At | D' Este Dr (Northbound) |      |       |   | D' Este Dr (Southbound) |      |       |   | Guinida Ln (Eastbound) |      |       |   | Guinida Ln (Westbound) |      |       |   | Total | Hourly Totals |
|---------------------------------|-------------------------|------|-------|---|-------------------------|------|-------|---|------------------------|------|-------|---|------------------------|------|-------|---|-------|---------------|
|                                 | Left                    | Thru | Right | U | Left                    | Thru | Right | U | Left                   | Thru | Right | U | Left                   | Thru | Right | U |       |               |
| 6:00 AM                         | 1                       | 0    | 0     | 0 | 1                       | 0    | 1     | 0 | 0                      | 0    | 0     | 0 | 0                      | 0    | 0     | 0 | 3     |               |
| 6:05 AM                         | 0                       | 0    | 0     | 0 | 0                       | 0    | 0     | 0 | 0                      | 0    | 0     | 0 | 0                      | 0    | 0     | 0 | 0     | 0             |
| 6:10 AM                         | 0                       | 0    | 0     | 0 | 0                       | 0    | 0     | 0 | 0                      | 1    | 0     | 0 | 0                      | 0    | 0     | 0 | 1     |               |
| 6:15 AM                         | 0                       | 0    | 0     | 0 | 0                       | 0    | 0     | 0 | 0                      | 1    | 0     | 0 | 0                      | 2    | 0     | 0 | 3     |               |
| 6:20 AM                         | 0                       | 0    | 0     | 0 | 1                       | 0    | 0     | 0 | 0                      | 1    | 0     | 0 | 0                      | 1    | 0     | 0 | 3     |               |
| 6:25 AM                         | 0                       | 0    | 0     | 0 | 1                       | 0    | 0     | 0 | 0                      | 1    | 0     | 0 | 0                      | 0    | 0     | 0 | 2     |               |
| 6:30 AM                         | 0                       | 0    | 0     | 0 | 0                       | 0    | 0     | 0 | 0                      | 1    | 0     | 0 | 0                      | 1    | 0     | 0 | 2     |               |
| 6:35 AM                         | 0                       | 0    | 0     | 0 | 0                       | 0    | 0     | 0 | 0                      | 0    | 0     | 0 | 0                      | 3    | 0     | 0 | 3     |               |
| 6:40 AM                         | 1                       | 0    | 0     | 0 | 0                       | 0    | 1     | 0 | 1                      | 2    | 0     | 0 | 0                      | 2    | 0     | 0 | 7     |               |
| 6:45 AM                         | 0                       | 0    | 0     | 0 | 0                       | 0    | 0     | 0 | 0                      | 3    | 0     | 0 | 0                      | 0    | 0     | 0 | 3     |               |
| 6:50 AM                         | 0                       | 0    | 0     | 0 | 0                       | 0    | 1     | 0 | 0                      | 2    | 0     | 0 | 0                      | 2    | 0     | 0 | 5     |               |
| 6:55 AM                         | 0                       | 0    | 0     | 0 | 1                       | 0    | 0     | 0 | 0                      | 0    | 0     | 0 | 0                      | 3    | 0     | 0 | 4     | 36            |
| 7:00 AM                         | 0                       | 0    | 0     | 0 | 1                       | 0    | 1     | 0 | 1                      | 3    | 0     | 0 | 0                      | 2    | 1     | 0 | 9     | 42            |
| 7:05 AM                         | 0                       | 0    | 1     | 0 | 3                       | 0    | 0     | 0 | 0                      | 1    | 0     | 0 | 0                      | 1    | 0     | 0 | 6     | 48            |
| 7:10 AM                         | 0                       | 0    | 0     | 0 | 0                       | 0    | 0     | 0 | 0                      | 1    | 0     | 0 | 0                      | 2    | 0     | 0 | 3     | 50            |
| 7:15 AM                         | 0                       | 0    | 0     | 0 | 0                       | 1    | 0     | 0 | 0                      | 1    | 0     | 0 | 0                      | 1    | 0     | 0 | 3     | 50            |
| 7:20 AM                         | 0                       | 0    | 0     | 0 | 0                       | 0    | 2     | 0 | 0                      | 0    | 0     | 0 | 0                      | 0    | 0     | 0 | 2     | 49            |
| 7:25 AM                         | 0                       | 0    | 0     | 0 | 0                       | 0    | 0     | 0 | 0                      | 3    | 0     | 0 | 0                      | 4    | 0     | 0 | 7     | 54            |
| 7:30 AM                         | 0                       | 0    | 1     | 0 | 0                       | 0    | 2     | 0 | 0                      | 2    | 0     | 0 | 1                      | 2    | 0     | 0 | 8     | 60            |
| 7:35 AM                         | 1                       | 0    | 0     | 0 | 0                       | 0    | 0     | 0 | 0                      | 3    | 0     | 0 | 0                      | 5    | 0     | 0 | 9     | 66            |
| 7:40 AM                         | 4                       | 0    | 0     | 0 | 1                       | 0    | 0     | 0 | 0                      | 1    | 0     | 0 | 0                      | 8    | 1     | 0 | 15    | 74            |
| 7:45 AM                         | 0                       | 0    | 0     | 0 | 0                       | 0    | 0     | 0 | 1                      | 2    | 1     | 0 | 0                      | 6    | 0     | 0 | 10    | 81            |
| 7:50 AM                         | 0                       | 0    | 1     | 0 | 0                       | 0    | 1     | 0 | 0                      | 3    | 0     | 0 | 0                      | 4    | 0     | 0 | 9     | 85            |
| 7:55 AM                         | 1                       | 0    | 0     | 0 | 0                       | 0    | 0     | 0 | 0                      | 2    | 1     | 0 | 0                      | 4    | 0     | 0 | 8     | 89            |
| 8:00 AM                         | 0                       | 0    | 0     | 0 | 0                       | 0    | 0     | 0 | 0                      | 4    | 0     | 0 | 0                      | 1    | 0     | 0 | 5     | 85            |
| 8:05 AM                         | 0                       | 0    | 0     | 0 | 0                       | 0    | 0     | 0 | 1                      | 7    | 0     | 0 | 1                      | 4    | 1     | 0 | 14    | 93            |
| 8:10 AM                         | 1                       | 0    | 0     | 0 | 0                       | 0    | 0     | 0 | 0                      | 3    | 1     | 0 | 0                      | 6    | 0     | 0 | 11    | 101           |
| 8:15 AM                         | 2                       | 0    | 0     | 0 | 0                       | 0    | 1     | 0 | 0                      | 3    | 0     | 0 | 0                      | 2    | 0     | 0 | 8     | 106           |
| 8:20 AM                         | 1                       | 0    | 0     | 0 | 1                       | 0    | 0     | 0 | 0                      | 6    | 3     | 0 | 1                      | 1    | 1     | 0 | 14    | 118           |
| 8:25 AM                         | 0                       | 0    | 0     | 0 | 0                       | 0    | 0     | 0 | 0                      | 5    | 2     | 0 | 0                      | 1    | 0     | 0 | 8     | 119           |
| 8:30 AM                         | 0                       | 0    | 0     | 0 | 0                       | 0    | 0     | 0 | 1                      | 7    | 0     | 0 | 0                      | 5    | 0     | 0 | 13    | 124           |
| 8:35 AM                         | 1                       | 0    | 1     | 0 | 0                       | 0    | 0     | 0 | 0                      | 2    | 0     | 0 | 0                      | 1    | 0     | 0 | 5     | 120           |
| 8:40 AM                         | 0                       | 0    | 0     | 0 | 0                       | 0    | 1     | 0 | 0                      | 4    | 0     | 0 | 0                      | 1    | 0     | 0 | 6     | 111           |
| 8:45 AM                         | 0                       | 0    | 0     | 0 | 0                       | 0    | 0     | 0 | 0                      | 3    | 0     | 0 | 0                      | 1    | 0     | 0 | 4     | 105           |
| 8:50 AM                         | 0                       | 0    | 0     | 0 | 0                       | 0    | 0     | 0 | 0                      | 0    | 0     | 0 | 0                      | 1    | 0     | 0 | 1     | 97            |
| 8:55 AM                         | 0                       | 0    | 0     | 0 | 0                       | 0    | 0     | 0 | 0                      | 0    | 0     | 0 | 0                      | 0    | 0     | 0 | 0     | 89            |
| 9:00 AM                         | 1                       | 0    | 0     | 0 | 1                       | 0    | 0     | 0 | 0                      | 0    | 0     | 0 | 0                      | 3    | 0     | 0 | 5     | 89            |
| 9:05 AM                         | 0                       | 0    | 0     | 0 | 0                       | 0    | 1     | 0 | 1                      | 0    | 1     | 0 | 0                      | 1    | 0     | 0 | 4     | 79            |

Attachment B

| 5-Min Count Period Beginning At | D' Este Dr (Northbound) |      |       |   | D' Este Dr (Southbound) |      |       |   | Guinida Ln (Eastbound) |      |       |   | Guinida Ln (Westbound) |      |       |   | Total | Hourly Totals |
|---------------------------------|-------------------------|------|-------|---|-------------------------|------|-------|---|------------------------|------|-------|---|------------------------|------|-------|---|-------|---------------|
|                                 | Left                    | Thru | Right | U | Left                    | Thru | Right | U | Left                   | Thru | Right | U | Left                   | Thru | Right | U |       |               |
| 9:10 AM                         | 0                       | 0    | 0     | 0 | 1                       | 0    | 0     | 0 | 0                      | 0    | 1     | 0 | 0                      | 0    | 0     | 0 | 2     | 70            |
| 9:15 AM                         | 0                       | 0    | 0     | 0 | 0                       | 0    | 1     | 0 | 0                      | 0    | 0     | 0 | 0                      | 0    | 0     | 0 | 1     | 63            |
| 9:20 AM                         | 0                       | 0    | 0     | 0 | 0                       | 0    | 1     | 0 | 0                      | 1    | 1     | 0 | 0                      | 0    | 2     | 0 | 5     | 54            |
| 9:25 AM                         | 0                       | 0    | 1     | 0 | 0                       | 0    | 0     | 0 | 3                      | 1    | 0     | 0 | 0                      | 0    | 0     | 0 | 5     | 51            |
| 9:30 AM                         | 0                       | 0    | 0     | 0 | 1                       | 0    | 0     | 0 | 0                      | 1    | 0     | 0 | 0                      | 0    | 1     | 0 | 3     | 41            |
| 9:35 AM                         | 0                       | 0    | 0     | 0 | 0                       | 0    | 1     | 0 | 0                      | 0    | 0     | 0 | 1                      | 2    | 0     | 0 | 4     | 40            |
| 9:40 AM                         | 0                       | 0    | 0     | 0 | 0                       | 0    | 0     | 0 | 1                      | 0    | 0     | 0 | 0                      | 1    | 0     | 0 | 2     | 36            |
| 9:45 AM                         | 0                       | 0    | 0     | 0 | 0                       | 0    | 0     | 0 | 0                      | 2    | 0     | 0 | 0                      | 0    | 0     | 0 | 2     | 34            |
| 9:50 AM                         | 0                       | 0    | 0     | 0 | 2                       | 0    | 2     | 0 | 0                      | 0    | 0     | 0 | 0                      | 0    | 1     | 0 | 5     | 38            |
| 9:55 AM                         | 1                       | 0    | 0     | 0 | 0                       | 0    | 0     | 0 | 0                      | 0    | 0     | 0 | 0                      | 0    | 0     | 0 | 1     | 39            |
| 10:00 AM                        | 0                       | 0    | 0     | 0 | 0                       | 0    | 1     | 0 | 0                      | 3    | 0     | 0 | 0                      | 1    | 0     | 0 | 5     | 39            |
| 10:05 AM                        | 0                       | 0    | 0     | 0 | 0                       | 0    | 0     | 0 | 0                      | 1    | 0     | 0 | 0                      | 3    | 0     | 0 | 4     | 39            |
| 10:10 AM                        | 0                       | 0    | 0     | 0 | 1                       | 0    | 0     | 0 | 0                      | 0    | 0     | 0 | 0                      | 0    | 0     | 0 | 1     | 38            |
| 10:15 AM                        | 0                       | 0    | 1     | 0 | 0                       | 0    | 0     | 0 | 0                      | 1    | 0     | 0 | 0                      | 2    | 0     | 0 | 4     | 41            |
| 10:20 AM                        | 0                       | 0    | 0     | 0 | 1                       | 0    | 0     | 0 | 1                      | 1    | 0     | 0 | 0                      | 4    | 0     | 0 | 7     | 43            |
| 10:25 AM                        | 0                       | 0    | 0     | 0 | 0                       | 0    | 0     | 0 | 0                      | 1    | 0     | 0 | 0                      | 1    | 0     | 0 | 2     | 40            |
| 10:30 AM                        | 0                       | 0    | 0     | 0 | 0                       | 1    | 0     | 0 | 0                      | 2    | 0     | 0 | 0                      | 0    | 2     | 0 | 5     | 42            |
| 10:35 AM                        | 0                       | 0    | 0     | 0 | 0                       | 0    | 1     | 0 | 0                      | 0    | 0     | 0 | 0                      | 0    | 0     | 0 | 1     | 39            |
| 10:40 AM                        | 0                       | 0    | 0     | 0 | 0                       | 0    | 0     | 0 | 0                      | 1    | 0     | 0 | 0                      | 2    | 0     | 0 | 3     | 40            |
| 10:45 AM                        | 0                       | 0    | 0     | 0 | 0                       | 0    | 0     | 0 | 0                      | 3    | 0     | 0 | 0                      | 0    | 0     | 0 | 3     | 41            |
| 10:50 AM                        | 0                       | 0    | 0     | 0 | 0                       | 0    | 0     | 0 | 0                      | 0    | 0     | 0 | 0                      | 3    | 0     | 0 | 3     | 39            |
| 10:55 AM                        | 0                       | 0    | 2     | 0 | 0                       | 0    | 0     | 0 | 0                      | 1    | 0     | 0 | 0                      | 2    | 0     | 0 | 5     | 43            |
| 11:00 AM                        | 0                       | 0    | 0     | 0 | 0                       | 0    | 0     | 0 | 0                      | 1    | 0     | 0 | 0                      | 1    | 0     | 0 | 2     | 40            |
| 11:05 AM                        | 0                       | 0    | 0     | 0 | 0                       | 0    | 1     | 0 | 1                      | 2    | 0     | 0 | 0                      | 1    | 0     | 0 | 5     | 41            |
| 11:10 AM                        | 0                       | 0    | 0     | 0 | 1                       | 0    | 0     | 0 | 1                      | 1    | 0     | 0 | 0                      | 0    | 1     | 0 | 4     | 44            |
| 11:15 AM                        | 0                       | 0    | 0     | 0 | 2                       | 0    | 0     | 0 | 1                      | 1    | 0     | 0 | 0                      | 2    | 0     | 0 | 6     | 46            |
| 11:20 AM                        | 0                       | 0    | 0     | 0 | 0                       | 0    | 1     | 0 | 1                      | 0    | 0     | 0 | 0                      | 3    | 1     | 0 | 6     | 45            |
| 11:25 AM                        | 0                       | 0    | 0     | 0 | 0                       | 0    | 1     | 0 | 0                      | 0    | 0     | 0 | 0                      | 1    | 0     | 0 | 2     | 45            |
| 11:30 AM                        | 1                       | 0    | 0     | 0 | 0                       | 0    | 0     | 0 | 0                      | 1    | 0     | 0 | 0                      | 2    | 0     | 0 | 4     | 44            |
| 11:35 AM                        | 0                       | 0    | 0     | 0 | 0                       | 0    | 0     | 0 | 0                      | 3    | 0     | 0 | 0                      | 2    | 0     | 0 | 5     | 48            |
| 11:40 AM                        | 0                       | 0    | 0     | 0 | 0                       | 0    | 0     | 0 | 0                      | 0    | 1     | 0 | 1                      | 1    | 0     | 0 | 3     | 48            |
| 11:45 AM                        | 0                       | 0    | 0     | 0 | 0                       | 0    | 1     | 0 | 0                      | 1    | 0     | 0 | 0                      | 2    | 0     | 0 | 4     | 49            |
| 11:50 AM                        | 0                       | 0    | 0     | 0 | 1                       | 0    | 0     | 0 | 1                      | 1    | 0     | 0 | 0                      | 2    | 1     | 0 | 6     | 52            |
| 11:55 AM                        | 1                       | 0    | 1     | 0 | 0                       | 0    | 0     | 0 | 0                      | 0    | 0     | 0 | 1                      | 1    | 0     | 0 | 4     | 51            |
| 12:00 PM                        | 0                       | 0    | 0     | 0 | 0                       | 0    | 0     | 0 | 0                      | 0    | 0     | 0 | 1                      | 3    | 0     | 0 | 4     | 53            |
| 12:05 PM                        | 1                       | 0    | 1     | 0 | 0                       | 0    | 1     | 0 | 2                      | 1    | 0     | 0 | 0                      | 2    | 0     | 0 | 8     | 56            |
| 12:10 PM                        | 0                       | 0    | 0     | 0 | 1                       | 0    | 0     | 0 | 0                      | 1    | 1     | 0 | 1                      | 4    | 0     | 0 | 8     | 60            |
| 12:15 PM                        | 0                       | 0    | 0     | 0 | 2                       | 0    | 0     | 0 | 0                      | 1    | 1     | 0 | 0                      | 1    | 0     | 0 | 5     | 59            |
| 12:20 PM                        | 0                       | 0    | 2     | 0 | 0                       | 0    | 1     | 0 | 0                      | 2    | 1     | 0 | 0                      | 3    | 1     | 0 | 10    | 63            |
| 12:25 PM                        | 0                       | 0    | 1     | 0 | 0                       | 0    | 0     | 0 | 0                      | 6    | 0     | 0 | 0                      | 1    | 0     | 0 | 8     | 69            |
| 12:30 PM                        | 0                       | 0    | 0     | 0 | 0                       | 0    | 0     | 0 | 0                      | 2    | 1     | 0 | 0                      | 5    | 0     | 0 | 8     | 73            |
| 12:35 PM                        | 0                       | 0    | 0     | 0 | 1                       | 0    | 0     | 0 | 0                      | 1    | 0     | 0 | 0                      | 0    | 0     | 0 | 2     | 70            |
| 12:40 PM                        | 0                       | 0    | 0     | 0 | 0                       | 0    | 1     | 0 | 0                      | 1    | 2     | 0 | 0                      | 2    | 0     | 0 | 6     | 73            |
| 12:45 PM                        | 0                       | 0    | 0     | 0 | 0                       | 0    | 0     | 0 | 0                      | 3    | 0     | 0 | 0                      | 4    | 0     | 0 | 7     | 76            |
| 12:50 PM                        | 0                       | 0    | 1     | 0 | 0                       | 0    | 0     | 0 | 0                      | 1    | 1     | 0 | 0                      | 0    | 1     | 0 | 4     | 74            |
| 12:55 PM                        | 0                       | 0    | 1     | 0 | 0                       | 0    | 0     | 0 | 0                      | 2    | 0     | 0 | 0                      | 4    | 0     | 0 | 7     | 77            |
| 1:00 PM                         | 0                       | 0    | 0     | 0 | 0                       | 0    | 0     | 0 | 0                      | 2    | 0     | 0 | 0                      | 2    | 0     | 0 | 4     | 77            |
| 1:05 PM                         | 0                       | 0    | 0     | 0 | 1                       | 0    | 0     | 0 | 1                      | 3    | 1     | 0 | 0                      | 1    | 0     | 0 | 7     | 76            |
| 1:10 PM                         | 0                       | 0    | 0     | 0 | 0                       | 0    | 0     | 0 | 0                      | 4    | 0     | 0 | 0                      | 1    | 1     | 0 | 6     | 74            |
| 1:15 PM                         | 0                       | 0    | 0     | 0 | 0                       | 1    | 0     | 0 | 0                      | 1    | 0     | 0 | 0                      | 2    | 0     | 0 | 4     | 73            |
| 1:20 PM                         | 0                       | 0    | 0     | 0 | 0                       | 0    | 0     | 0 | 0                      | 0    | 0     | 0 | 0                      | 1    | 0     | 0 | 1     | 64            |
| 1:25 PM                         | 0                       | 0    | 1     | 0 | 0                       | 0    | 0     | 0 | 0                      | 2    | 0     | 0 | 0                      | 2    | 0     | 0 | 5     | 61            |
| 1:30 PM                         | 0                       | 0    | 0     | 0 | 0                       | 0    | 0     | 0 | 0                      | 0    | 0     | 0 | 0                      | 1    | 0     | 0 | 1     | 54            |
| 1:35 PM                         | 0                       | 0    | 0     | 0 | 0                       | 0    | 0     | 0 | 1                      | 2    | 0     | 0 | 0                      | 1    | 0     | 0 | 4     | 56            |
| 1:40 PM                         | 0                       | 0    | 1     | 0 | 0                       | 0    | 1     | 0 | 0                      | 1    | 0     | 0 | 0                      | 0    | 0     | 0 | 3     | 53            |
| 1:45 PM                         | 0                       | 0    | 0     | 0 | 1                       | 0    | 0     | 0 | 0                      | 1    | 0     | 0 | 0                      | 1    | 0     | 0 | 3     | 49            |
| 1:50 PM                         | 0                       | 0    | 1     | 0 | 0                       | 0    | 0     | 0 | 1                      | 1    | 0     | 0 | 0                      | 0    | 0     | 0 | 3     | 48            |
| 1:55 PM                         | 0                       | 0    | 0     | 0 | 0                       | 0    | 1     | 0 | 0                      | 1    | 0     | 0 | 0                      | 1    | 0     | 0 | 3     | 44            |
| 2:00 PM                         | 1                       | 0    | 0     | 0 | 0                       | 0    | 1     | 0 | 1                      | 4    | 0     | 0 | 0                      | 2    | 0     | 0 | 9     | 49            |
| 2:05 PM                         | 0                       | 0    | 0     | 0 | 0                       | 0    | 0     | 0 | 0                      | 0    | 0     | 0 | 0                      | 1    | 0     | 0 | 1     | 43            |
| 2:10 PM                         | 0                       | 0    | 0     | 0 | 0                       | 0    | 0     | 0 | 0                      | 0    | 0     | 0 | 1                      | 0    | 0     | 0 | 1     | 38            |
| 2:15 PM                         | 0                       | 0    | 1     | 0 | 0                       | 0    | 1     | 0 | 1                      | 1    | 0     | 0 | 1                      | 1    | 0     | 0 | 6     | 40            |
| 2:20 PM                         | 0                       | 0    | 0     | 0 | 1                       | 0    | 0     | 0 | 0                      | 1    | 0     | 0 | 1                      | 1    | 0     | 0 | 4     | 43            |
| 2:25 PM                         | 1                       | 0    | 0     | 0 | 0                       | 0    | 0     | 0 | 1                      | 2    | 1     | 0 | 0                      | 2    | 0     | 0 | 7     | 45            |
| 2:30 PM                         | 0                       | 0    | 0     | 0 | 0                       | 0    | 1     | 0 | 1                      | 1    | 0     | 0 | 0                      | 2    | 0     | 0 | 5     | 49            |
| 2:35 PM                         | 0                       | 0    | 0     | 0 | 0                       | 0    | 0     | 0 | 0                      | 2    | 0     | 0 | 0                      | 1    | 0     | 0 | 3     | 48            |
| 2:40 PM                         | 0                       | 0    | 0     | 0 | 0                       | 0    | 0     | 0 | 0                      | 0    | 0     | 0 | 0                      | 1    | 0     | 0 | 1     | 46            |
| 2:45 PM                         | 0                       | 0    | 2     | 0 | 0                       | 0    | 0     | 0 | 1                      | 0    | 1     | 0 | 0                      | 3    | 0     | 0 | 7     | 50            |
| 2:50 PM                         | 0                       | 0    | 1     | 0 | 0                       | 0    | 0     | 0 | 0                      | 1    | 0     | 0 | 0                      | 0    | 0     | 0 | 2     | 49            |
| 2:55 PM                         | 0                       | 0    | 0     | 0 | 0                       | 0    | 0     | 0 | 1                      | 2    | 0     | 0 | 0                      | 1    | 0     | 0 | 4     | 50            |
| 3:00 PM                         | 0                       | 0    | 0     | 0 | 0                       | 0    | 0     | 0 | 0                      | 2    | 0     | 0 | 0                      | 1    | 0     | 0 | 3     | 44            |
| 3:05 PM                         | 0                       | 1    | 0     | 0 | 0                       | 0    | 2     | 0 | 1                      | 3    | 0     | 0 | 0                      | 3    | 1     | 0 | 11    | 54            |
| 3:10 PM                         | 0                       | 0    | 0     | 0 | 0                       | 0    | 0     | 0 | 1                      | 1    | 0     | 0 | 0                      | 1    | 0     | 0 | 3     | 56            |
| 3:15 PM                         | 1                       | 0    | 0     | 0 | 0                       | 0    | 2     | 0 | 0                      | 1    | 0     | 0 | 1                      | 1    | 0     | 0 | 6     | 56            |
| 3:20 PM                         | 0                       | 0    | 0     | 0 | 0                       | 0    | 1     | 0 | 1                      | 2    | 0     | 0 | 0                      | 1    | 0     | 0 | 5     | 57            |
| 3:25 PM                         | 1                       | 0    | 0     | 0 | 0                       | 0    | 0     | 0 | 2                      | 4    | 0     | 0 | 0                      | 4    | 0     | 0 | 11    | 61            |
| 3:30 PM                         | 0                       | 0    | 0     | 0 | 0                       | 0    | 0     | 0 | 0                      | 1    | 0     | 0 | 0                      | 1    | 0     | 0 | 2     | 58            |
| 3:35 PM                         | 0                       | 0    | 0     | 0 | 0                       | 0    | 0     | 0 | 0                      | 1    | 1     | 0 | 0                      | 1    | 0     | 0 | 3     | 58            |
| 3:40 PM                         | 0                       | 0    | 0     | 0 | 0                       | 1    | 1     | 0 | 0                      | 0    | 2     | 0 | 0                      | 2    | 0     | 0 | 6     | 63            |
| 3:45 PM                         | 0                       | 0    | 1     | 0 | 1                       | 0    | 0     | 0 | 0                      | 6    | 0     | 0 | 0                      | 1    | 0     | 0 | 9     | 65            |
| 3:50 PM                         | 0                       | 0    | 0     | 0 | 0                       | 0    | 0     | 0 | 2                      | 2    | 0     | 0 | 1                      | 0    | 0     | 0 | 5     | 68            |
| 3:55 PM                         | 1                       | 0    | 2     | 0 | 0                       | 0    | 0     | 0 | 1                      | 0    | 1     | 0 | 0                      | 1    | 0     | 0 | 6     | 70            |
| 4:00 PM                         | 0                       | 0    | 0     | 0 | 0                       | 0    | 0     | 0 | 0                      | 1    | 0     | 0 | 0                      | 4    | 0     | 0 | 5     | 72            |
| 4:05 PM                         | 0                       | 0    | 0     | 0 | 0                       | 0    | 1     | 0 | 2                      | 1    | 0     | 0 | 0                      | 0    | 0     | 0 | 4     | 65            |
| 4:10 PM                         | 0                       | 0    | 0     | 0 | 0                       | 0    | 0     | 0 | 2                      | 1    | 1     | 0 | 1                      | 2    | 0     | 0 | 7     | 69            |
| 4:15 PM                         | 1                       | 0    | 0     | 0 | 0                       | 0    | 1     | 0 | 1                      | 8    | 0     | 0 | 0                      | 2    | 0     | 0 | 13    | 76            |
| 4:20 PM                         | 1                       | 0    | 0     | 0 | 0                       | 0    | 0     | 0 | 2                      | 2    | 0     | 0 | 0                      | 2    | 0     | 0 | 7     | 78            |
| 4:25 PM                         | 0                       | 1    | 0     | 0 | 0                       | 0    | 0     | 0 | 0                      | 0    | 0     | 0 | 0                      | 2    | 0     | 0 | 3     | 70            |
| 4:30 PM                         | 0                       | 0    | 0     | 0 | 0                       | 0    | 0     | 0 | 0                      | 2    | 0     | 0 | 0                      | 1    | 0     | 0 | 3     | 71            |

**Attachment B**

| 5-Min Count Period Beginning At | D' Este Dr (Northbound) |      |       |   | D' Este Dr (Southbound) |      |       |   | Guinida Ln (Eastbound) |      |       |   | Guinida Ln (Westbound) |      |       |   | Total | Hourly Totals |    |
|---------------------------------|-------------------------|------|-------|---|-------------------------|------|-------|---|------------------------|------|-------|---|------------------------|------|-------|---|-------|---------------|----|
|                                 | Left                    | Thru | Right | U | Left                    | Thru | Right | U | Left                   | Thru | Right | U | Left                   | Thru | Right | U |       |               |    |
| 4:35 PM                         | 0                       | 0    | 0     | 0 | 0                       | 0    | 0     | 0 | 0                      | 0    | 0     | 0 | 0                      | 1    | 1     | 0 | 0     | 2             | 70 |
| 4:40 PM                         | 0                       | 0    | 0     | 0 | 0                       | 0    | 0     | 0 | 0                      | 1    | 2     | 1 | 0                      | 0    | 1     | 0 | 0     | 5             | 69 |
| 4:45 PM                         | 0                       | 0    | 0     | 0 | 0                       | 0    | 1     | 0 | 0                      | 0    | 1     | 0 | 0                      | 0    | 3     | 0 | 0     | 5             | 65 |
| 4:50 PM                         | 0                       | 1    | 0     | 0 | 0                       | 0    | 1     | 0 | 0                      | 0    | 3     | 0 | 0                      | 0    | 1     | 0 | 0     | 6             | 66 |
| 4:55 PM                         | 0                       | 0    | 0     | 0 | 0                       | 0    | 0     | 0 | 0                      | 1    | 2     | 0 | 0                      | 0    | 2     | 0 | 0     | 5             | 65 |
| 5:00 PM                         | 0                       | 0    | 1     | 0 | 0                       | 0    | 1     | 0 | 0                      | 0    | 2     | 0 | 0                      | 0    | 5     | 0 | 0     | 9             | 69 |
| 5:05 PM                         | 0                       | 0    | 0     | 0 | 0                       | 0    | 1     | 0 | 0                      | 1    | 1     | 0 | 0                      | 1    | 2     | 0 | 0     | 6             | 71 |
| 5:10 PM                         | 2                       | 0    | 0     | 0 | 0                       | 0    | 0     | 0 | 0                      | 1    | 3     | 0 | 0                      | 0    | 0     | 0 | 0     | 6             | 70 |
| 5:15 PM                         | 0                       | 0    | 0     | 0 | 0                       | 0    | 0     | 0 | 0                      | 1    | 1     | 0 | 0                      | 0    | 2     | 1 | 0     | 5             | 62 |
| 5:20 PM                         | 0                       | 0    | 0     | 0 | 0                       | 0    | 0     | 0 | 0                      | 1    | 3     | 0 | 0                      | 0    | 4     | 0 | 0     | 8             | 63 |
| 5:25 PM                         | 1                       | 0    | 0     | 0 | 0                       | 0    | 0     | 0 | 0                      | 0    | 4     | 0 | 0                      | 2    | 1     | 0 | 0     | 8             | 68 |
| 5:30 PM                         | 0                       | 0    | 0     | 0 | 0                       | 0    | 1     | 0 | 0                      | 0    | 1     | 0 | 0                      | 0    | 2     | 0 | 0     | 4             | 69 |
| 5:35 PM                         | 0                       | 0    | 0     | 0 | 0                       | 0    | 0     | 0 | 0                      | 0    | 3     | 1 | 0                      | 1    | 0     | 0 | 0     | 5             | 72 |
| 5:40 PM                         | 0                       | 0    | 0     | 0 | 0                       | 0    | 1     | 0 | 0                      | 1    | 5     | 1 | 0                      | 0    | 4     | 0 | 0     | 12            | 79 |
| 5:45 PM                         | 1                       | 0    | 0     | 0 | 0                       | 0    | 0     | 0 | 0                      | 0    | 1     | 0 | 0                      | 0    | 3     | 1 | 0     | 6             | 80 |
| 5:50 PM                         | 0                       | 0    | 0     | 0 | 0                       | 0    | 2     | 0 | 0                      | 0    | 4     | 1 | 0                      | 0    | 3     | 0 | 0     | 10            | 84 |
| 5:55 PM                         | 0                       | 0    | 0     | 0 | 1                       | 0    | 1     | 0 | 0                      | 0    | 4     | 1 | 0                      | 0    | 3     | 1 | 0     | 11            | 90 |
| 6:00 PM                         | 0                       | 0    | 0     | 0 | 0                       | 0    | 0     | 0 | 0                      | 0    | 0     | 1 | 0                      | 0    | 2     | 0 | 0     | 3             | 84 |
| 6:05 PM                         | 0                       | 0    | 0     | 0 | 0                       | 0    | 0     | 0 | 0                      | 0    | 2     | 0 | 0                      | 0    | 0     | 0 | 0     | 2             | 80 |
| 6:10 PM                         | 0                       | 0    | 0     | 0 | 1                       | 0    | 0     | 0 | 0                      | 0    | 1     | 0 | 0                      | 0    | 0     | 0 | 0     | 2             | 76 |
| 6:15 PM                         | 0                       | 0    | 0     | 0 | 0                       | 0    | 0     | 0 | 0                      | 0    | 0     | 0 | 0                      | 0    | 1     | 0 | 0     | 1             | 72 |
| 6:20 PM                         | 1                       | 0    | 0     | 0 | 0                       | 0    | 0     | 0 | 0                      | 0    | 4     | 1 | 0                      | 1    | 0     | 0 | 0     | 7             | 71 |
| 6:25 PM                         | 0                       | 0    | 0     | 0 | 0                       | 0    | 0     | 0 | 0                      | 0    | 0     | 1 | 0                      | 0    | 2     | 1 | 0     | 4             | 67 |
| 6:30 PM                         | 0                       | 0    | 0     | 0 | 0                       | 0    | 0     | 0 | 0                      | 0    | 3     | 0 | 0                      | 0    | 2     | 2 | 0     | 7             | 70 |
| 6:35 PM                         | 0                       | 0    | 0     | 0 | 1                       | 0    | 1     | 0 | 0                      | 0    | 1     | 0 | 0                      | 0    | 2     | 0 | 0     | 5             | 70 |
| 6:40 PM                         | 0                       | 1    | 1     | 0 | 0                       | 0    | 0     | 0 | 0                      | 0    | 2     | 1 | 0                      | 0    | 2     | 1 | 0     | 8             | 66 |
| 6:45 PM                         | 0                       | 0    | 0     | 0 | 0                       | 0    | 0     | 0 | 0                      | 0    | 1     | 0 | 0                      | 0    | 1     | 0 | 0     | 2             | 62 |
| 6:50 PM                         | 0                       | 0    | 3     | 0 | 0                       | 0    | 0     | 0 | 0                      | 0    | 2     | 0 | 0                      | 0    | 2     | 1 | 0     | 8             | 60 |
| 6:55 PM                         | 0                       | 0    | 0     | 0 | 0                       | 0    | 1     | 0 | 0                      | 1    | 2     | 3 | 0                      | 0    | 3     | 0 | 0     | 10            | 59 |
| 7:00 PM                         | 1                       | 0    | 0     | 0 | 0                       | 0    | 0     | 0 | 0                      | 0    | 3     | 0 | 0                      | 1    | 2     | 0 | 0     | 7             | 63 |
| 7:05 PM                         | 1                       | 0    | 0     | 0 | 0                       | 0    | 0     | 0 | 0                      | 1    | 4     | 0 | 0                      | 0    | 1     | 0 | 0     | 7             | 68 |
| 7:10 PM                         | 0                       | 0    | 0     | 0 | 2                       | 0    | 0     | 0 | 0                      | 3    | 4     | 0 | 0                      | 0    | 2     | 1 | 0     | 12            | 78 |
| 7:15 PM                         | 0                       | 0    | 0     | 0 | 1                       | 0    | 1     | 0 | 0                      | 0    | 1     | 0 | 0                      | 0    | 2     | 0 | 0     | 5             | 82 |
| 7:20 PM                         | 0                       | 0    | 0     | 0 | 1                       | 0    | 0     | 0 | 0                      | 0    | 2     | 0 | 0                      | 0    | 0     | 0 | 0     | 3             | 78 |
| 7:25 PM                         | 0                       | 0    | 0     | 0 | 1                       | 0    | 0     | 0 | 0                      | 0    | 0     | 0 | 0                      | 0    | 2     | 0 | 0     | 3             | 77 |
| 7:30 PM                         | 0                       | 0    | 0     | 0 | 1                       | 0    | 0     | 0 | 0                      | 0    | 3     | 0 | 0                      | 0    | 3     | 0 | 0     | 7             | 77 |
| 7:35 PM                         | 0                       | 0    | 0     | 0 | 0                       | 0    | 0     | 0 | 0                      | 0    | 0     | 1 | 0                      | 0    | 2     | 0 | 0     | 3             | 75 |
| 7:40 PM                         | 0                       | 0    | 0     | 0 | 0                       | 0    | 0     | 0 | 0                      | 1    | 2     | 0 | 0                      | 0    | 0     | 0 | 0     | 3             | 70 |
| 7:45 PM                         | 2                       | 0    | 0     | 0 | 0                       | 0    | 0     | 0 | 0                      | 1    | 1     | 1 | 0                      | 0    | 0     | 0 | 0     | 5             | 73 |
| 7:50 PM                         | 0                       | 0    | 0     | 0 | 0                       | 0    | 0     | 0 | 0                      | 0    | 2     | 0 | 0                      | 0    | 1     | 0 | 0     | 3             | 68 |
| 7:55 PM                         | 0                       | 0    | 0     | 0 | 0                       | 0    | 0     | 0 | 0                      | 0    | 2     | 0 | 0                      | 0    | 1     | 2 | 0     | 5             | 63 |
| 8:00 PM                         | 0                       | 0    | 0     | 0 | 1                       | 0    | 0     | 0 | 0                      | 0    | 6     | 0 | 0                      | 0    | 1     | 0 | 0     | 8             | 64 |
| 8:05 PM                         | 0                       | 0    | 1     | 0 | 0                       | 0    | 0     | 0 | 0                      | 0    | 2     | 0 | 0                      | 0    | 0     | 0 | 0     | 3             | 60 |
| 8:10 PM                         | 0                       | 0    | 0     | 0 | 0                       | 0    | 0     | 0 | 0                      | 0    | 2     | 0 | 0                      | 0    | 2     | 0 | 0     | 4             | 52 |
| 8:15 PM                         | 0                       | 0    | 0     | 0 | 0                       | 0    | 0     | 0 | 0                      | 0    | 0     | 0 | 0                      | 0    | 2     | 0 | 0     | 2             | 49 |
| 8:20 PM                         | 0                       | 0    | 0     | 0 | 0                       | 0    | 2     | 0 | 0                      | 2    | 1     | 1 | 0                      | 0    | 2     | 0 | 0     | 8             | 54 |
| 8:25 PM                         | 0                       | 1    | 0     | 0 | 1                       | 0    | 0     | 0 | 0                      | 1    | 1     | 1 | 0                      | 0    | 0     | 0 | 0     | 5             | 56 |
| 8:30 PM                         | 1                       | 0    | 0     | 0 | 0                       | 0    | 0     | 0 | 0                      | 0    | 2     | 0 | 0                      | 1    | 2     | 0 | 0     | 6             | 55 |
| 8:35 PM                         | 0                       | 0    | 0     | 0 | 0                       | 0    | 0     | 0 | 0                      | 1    | 1     | 0 | 0                      | 1    | 1     | 0 | 0     | 4             | 56 |
| 8:40 PM                         | 0                       | 0    | 0     | 0 | 0                       | 0    | 0     | 0 | 0                      | 1    | 1     | 0 | 0                      | 0    | 2     | 0 | 0     | 4             | 57 |
| 8:45 PM                         | 0                       | 0    | 0     | 0 | 0                       | 0    | 1     | 0 | 0                      | 0    | 1     | 0 | 0                      | 1    | 1     | 0 | 0     | 4             | 56 |
| 8:50 PM                         | 0                       | 0    | 0     | 0 | 0                       | 0    | 1     | 0 | 0                      | 0    | 4     | 0 | 0                      | 0    | 2     | 1 | 0     | 8             | 61 |
| 8:55 PM                         | 0                       | 0    | 0     | 0 | 0                       | 0    | 0     | 0 | 0                      | 0    | 1     | 0 | 0                      | 0    | 0     | 1 | 0     | 2             | 58 |
| 9:00 PM                         | 0                       | 0    | 0     | 0 | 0                       | 0    | 0     | 0 | 0                      | 1    | 2     | 0 | 0                      | 1    | 0     | 0 | 0     | 4             | 54 |
| 9:05 PM                         | 0                       | 0    | 0     | 0 | 0                       | 0    | 0     | 0 | 0                      | 0    | 0     | 0 | 0                      | 0    | 1     | 0 | 0     | 1             | 52 |
| 9:10 PM                         | 1                       | 0    | 0     | 0 | 0                       | 0    | 1     | 0 | 0                      | 1    | 0     | 0 | 0                      | 0    | 0     | 0 | 0     | 3             | 51 |
| 9:15 PM                         | 0                       | 0    | 0     | 0 | 0                       | 0    | 0     | 0 | 0                      | 0    | 1     | 0 | 0                      | 0    | 0     | 1 | 0     | 2             | 51 |
| 9:20 PM                         | 0                       | 0    | 0     | 0 | 1                       | 0    | 1     | 0 | 0                      | 0    | 0     | 0 | 0                      | 0    | 1     | 1 | 0     | 4             | 47 |
| 9:25 PM                         | 0                       | 0    | 0     | 0 | 0                       | 0    | 0     | 0 | 0                      | 0    | 2     | 0 | 0                      | 0    | 0     | 0 | 0     | 2             | 44 |
| 9:30 PM                         | 0                       | 0    | 0     | 0 | 0                       | 0    | 0     | 0 | 0                      | 0    | 3     | 1 | 0                      | 0    | 0     | 1 | 0     | 5             | 43 |
| 9:35 PM                         | 0                       | 0    | 0     | 0 | 0                       | 0    | 0     | 0 | 0                      | 0    | 2     | 0 | 0                      | 0    | 0     | 2 | 0     | 4             | 43 |
| 9:40 PM                         | 0                       | 0    | 0     | 0 | 0                       | 0    | 1     | 0 | 0                      | 0    | 0     | 0 | 0                      | 0    | 0     | 1 | 0     | 2             | 41 |
| 9:45 PM                         | 0                       | 0    | 0     | 0 | 0                       | 0    | 1     | 0 | 0                      | 2    | 2     | 0 | 0                      | 0    | 0     | 1 | 0     | 6             | 43 |
| 9:50 PM                         | 0                       | 0    | 0     | 0 | 1                       | 0    | 0     | 0 | 0                      | 1    | 3     | 0 | 0                      | 0    | 0     | 1 | 0     | 6             | 41 |
| 9:55 PM                         | 0                       | 0    | 0     | 0 | 0                       | 0    | 1     | 0 | 0                      | 0    | 3     | 0 | 0                      | 0    | 0     | 0 | 0     | 4             | 43 |
| Peak 15-Min Flowrates           | Northbound              |      |       |   | Southbound              |      |       |   | Eastbound              |      |       |   | Westbound              |      |       |   | Total |               |    |
|                                 | Left                    | Thru | Right | U | Left                    | Thru | Right | U | Left                   | Thru | Right | U | Left                   | Thru | Right | U |       |               |    |
| All Vehicles                    | 4                       | 0    | 0     | 0 | 4                       | 0    | 0     | 0 | 4                      | 72   | 20    | 0 | 4                      | 28   | 4     | 0 | 140   |               |    |
| Heavy Trucks                    | 0                       | 0    | 0     | 0 | 0                       | 0    | 0     | 0 | 0                      | 4    | 0     | 0 | 4                      | 0    | 0     | 0 | 8     |               |    |
| Buses                           |                         | 8    |       |   |                         | 16   |       |   |                        | 0    |       |   |                        | 0    |       |   | 24    |               |    |
| Pedestrians                     | 0                       | 0    | 0     | 0 | 0                       | 0    | 0     | 0 | 0                      | 0    | 0     | 0 | 0                      | 0    | 0     | 0 | 0     |               |    |
| Bicycles                        |                         |      |       |   |                         |      |       |   |                        |      |       |   |                        |      |       |   |       |               |    |
| Scoters                         |                         |      |       |   |                         |      |       |   |                        |      |       |   |                        |      |       |   |       |               |    |
| <i>Comments:</i>                |                         |      |       |   |                         |      |       |   |                        |      |       |   |                        |      |       |   |       |               |    |

LOCATION: Antigua St -- Guinida Ln  
 CITY/STATE: Orange, CA

QC JOB #: 16966428  
 DATE: Wed, Apr 9 2025

Peak-Hour: 5:00 PM -- 6:00 PM  
 Peak 15-Min: 5:35 PM -- 5:50 PM

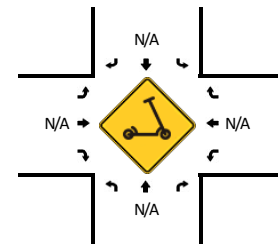
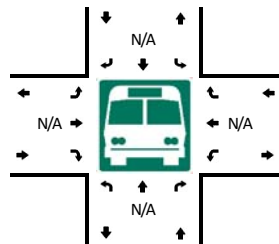
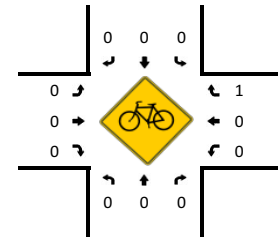
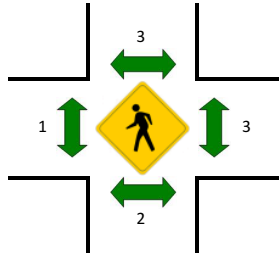
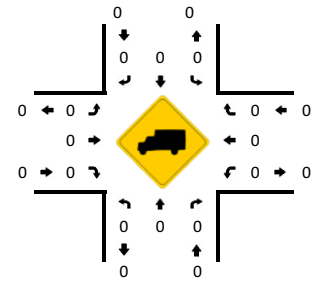
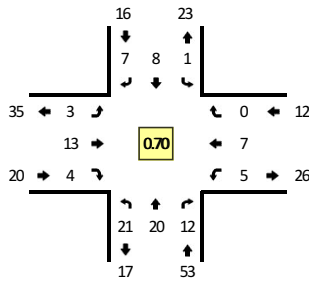

| 5-Min Count Period Beginning At | Antigua St (Northbound) |      |       |   | Antigua St (Southbound) |      |       |   | Guinida Ln (Eastbound) |      |       |   | Guinida Ln (Westbound) |      |       |   | Total | Hourly Totals |
|---------------------------------|-------------------------|------|-------|---|-------------------------|------|-------|---|------------------------|------|-------|---|------------------------|------|-------|---|-------|---------------|
|                                 | Left                    | Thru | Right | U | Left                    | Thru | Right | U | Left                   | Thru | Right | U | Left                   | Thru | Right | U |       |               |
| 6:00 AM                         | 0                       | 0    | 0     | 0 | 0                       | 1    | 0     | 0 | 1                      | 0    | 1     | 0 | 0                      | 2    | 0     | 0 | 5     |               |
| 6:05 AM                         | 0                       | 0    | 0     | 0 | 0                       | 0    | 0     | 0 | 0                      | 0    | 0     | 0 | 0                      | 0    | 0     | 0 | 0     |               |
| 6:10 AM                         | 1                       | 0    | 0     | 0 | 0                       | 0    | 0     | 0 | 0                      | 0    | 2     | 0 | 0                      | 0    | 0     | 0 | 3     |               |
| 6:15 AM                         | 2                       | 0    | 0     | 0 | 0                       | 0    | 0     | 0 | 0                      | 0    | 0     | 0 | 0                      | 1    | 0     | 0 | 3     |               |
| 6:20 AM                         | 1                       | 0    | 1     | 0 | 0                       | 0    | 1     | 0 | 0                      | 0    | 1     | 0 | 1                      | 0    | 0     | 0 | 5     |               |
| 6:25 AM                         | 1                       | 0    | 0     | 0 | 0                       | 1    | 1     | 0 | 0                      | 0    | 0     | 0 | 0                      | 0    | 0     | 0 | 3     |               |
| 6:30 AM                         | 3                       | 0    | 0     | 0 | 0                       | 0    | 0     | 0 | 0                      | 0    | 0     | 0 | 0                      | 2    | 1     | 0 | 6     |               |
| 6:35 AM                         | 2                       | 1    | 0     | 0 | 0                       | 1    | 0     | 0 | 0                      | 0    | 0     | 0 | 0                      | 1    | 0     | 0 | 5     |               |
| 6:40 AM                         | 0                       | 0    | 0     | 0 | 0                       | 2    | 0     | 0 | 1                      | 1    | 0     | 0 | 0                      | 0    | 0     | 0 | 4     |               |
| 6:45 AM                         | 1                       | 2    | 0     | 0 | 0                       | 0    | 0     | 0 | 0                      | 0    | 0     | 0 | 0                      | 0    | 0     | 0 | 3     |               |
| 6:50 AM                         | 0                       | 0    | 0     | 0 | 0                       | 1    | 0     | 0 | 1                      | 1    | 0     | 0 | 0                      | 0    | 0     | 0 | 3     |               |
| 6:55 AM                         | 3                       | 0    | 1     | 0 | 0                       | 0    | 0     | 0 | 0                      | 0    | 0     | 0 | 0                      | 0    | 0     | 0 | 4     | 44            |
| 7:00 AM                         | 1                       | 0    | 0     | 0 | 0                       | 2    | 1     | 0 | 0                      | 0    | 0     | 0 | 1                      | 4    | 0     | 0 | 9     | 48            |
| 7:05 AM                         | 3                       | 0    | 0     | 0 | 0                       | 0    | 0     | 0 | 0                      | 1    | 0     | 0 | 0                      | 0    | 0     | 0 | 4     | 52            |
| 7:10 AM                         | 2                       | 0    | 0     | 0 | 0                       | 2    | 1     | 0 | 0                      | 0    | 1     | 0 | 1                      | 2    | 0     | 0 | 9     | 58            |
| 7:15 AM                         | 1                       | 0    | 0     | 0 | 0                       | 1    | 0     | 0 | 0                      | 0    | 2     | 0 | 0                      | 2    | 0     | 0 | 6     | 61            |
| 7:20 AM                         | 1                       | 0    | 0     | 0 | 0                       | 2    | 0     | 0 | 0                      | 0    | 0     | 0 | 0                      | 0    | 0     | 0 | 3     | 59            |
| 7:25 AM                         | 1                       | 0    | 0     | 0 | 0                       | 0    | 1     | 0 | 1                      | 0    | 0     | 0 | 0                      | 0    | 0     | 0 | 3     | 59            |
| 7:30 AM                         | 1                       | 0    | 0     | 0 | 0                       | 0    | 0     | 0 | 0                      | 0    | 1     | 0 | 0                      | 2    | 0     | 0 | 4     | 57            |
| 7:35 AM                         | 0                       | 0    | 0     | 0 | 0                       | 2    | 0     | 0 | 0                      | 0    | 0     | 0 | 2                      | 5    | 0     | 0 | 9     | 61            |
| 7:40 AM                         | 2                       | 1    | 0     | 0 | 0                       | 2    | 0     | 0 | 1                      | 2    | 2     | 0 | 0                      | 0    | 0     | 0 | 10    | 67            |
| 7:45 AM                         | 3                       | 1    | 0     | 0 | 0                       | 2    | 0     | 0 | 0                      | 1    | 2     | 0 | 0                      | 0    | 0     | 0 | 9     | 73            |
| 7:50 AM                         | 0                       | 0    | 0     | 0 | 0                       | 1    | 0     | 0 | 0                      | 0    | 0     | 0 | 1                      | 1    | 0     | 0 | 3     | 73            |
| 7:55 AM                         | 3                       | 0    | 0     | 0 | 0                       | 1    | 0     | 0 | 0                      | 0    | 1     | 0 | 0                      | 0    | 0     | 0 | 5     | 74            |
| 8:00 AM                         | 3                       | 1    | 1     | 0 | 0                       | 0    | 0     | 0 | 0                      | 0    | 0     | 0 | 0                      | 0    | 0     | 0 | 5     | 70            |
| 8:05 AM                         | 2                       | 1    | 0     | 0 | 0                       | 0    | 1     | 0 | 1                      | 0    | 0     | 0 | 0                      | 0    | 0     | 0 | 5     | 71            |
| 8:10 AM                         | 3                       | 3    | 0     | 0 | 0                       | 0    | 1     | 0 | 1                      | 0    | 0     | 0 | 0                      | 2    | 0     | 0 | 10    | 72            |
| 8:15 AM                         | 0                       | 0    | 0     | 0 | 0                       | 0    | 0     | 0 | 0                      | 2    | 2     | 0 | 1                      | 1    | 0     | 0 | 6     | 72            |
| 8:20 AM                         | 3                       | 0    | 0     | 0 | 1                       | 0    | 0     | 0 | 0                      | 1    | 2     | 0 | 0                      | 0    | 0     | 0 | 7     | 76            |
| 8:25 AM                         | 1                       | 0    | 2     | 0 | 0                       | 0    | 0     | 0 | 0                      | 0    | 0     | 0 | 0                      | 1    | 0     | 0 | 4     | 77            |
| 8:30 AM                         | 1                       | 0    | 2     | 0 | 0                       | 1    | 1     | 0 | 0                      | 0    | 1     | 0 | 0                      | 1    | 0     | 0 | 7     | 80            |
| 8:35 AM                         | 0                       | 0    | 0     | 0 | 0                       | 0    | 0     | 0 | 0                      | 0    | 0     | 0 | 0                      | 2    | 0     | 0 | 2     | 73            |
| 8:40 AM                         | 0                       | 1    | 0     | 0 | 0                       | 0    | 0     | 0 | 1                      | 0    | 1     | 0 | 0                      | 0    | 0     | 0 | 3     | 66            |
| 8:45 AM                         | 1                       | 0    | 0     | 0 | 0                       | 0    | 0     | 0 | 0                      | 1    | 2     | 0 | 0                      | 1    | 0     | 0 | 5     | 62            |
| 8:50 AM                         | 2                       | 0    | 1     | 0 | 1                       | 1    | 0     | 0 | 0                      | 0    | 2     | 0 | 1                      | 0    | 0     | 0 | 8     | 67            |
| 8:55 AM                         | 2                       | 0    | 0     | 0 | 0                       | 0    | 0     | 0 | 0                      | 0    | 1     | 0 | 0                      | 0    | 0     | 0 | 3     | 65            |
| 9:00 AM                         | 0                       | 0    | 0     | 0 | 0                       | 1    | 0     | 0 | 0                      | 0    | 0     | 0 | 0                      | 1    | 0     | 0 | 2     | 62            |
| 9:05 AM                         | 0                       | 0    | 0     | 0 | 0                       | 0    | 0     | 0 | 1                      | 0    | 0     | 0 | 0                      | 1    | 0     | 0 | 2     | 59            |

Attachment B

| 5-Min Count Period Beginning At | Antigua St (Northbound) |      |       |   | Antigua St (Southbound) |      |       |   | Guinida Ln (Eastbound) |      |       |   | Guinida Ln (Westbound) |      |       |   | Total | Hourly Totals |
|---------------------------------|-------------------------|------|-------|---|-------------------------|------|-------|---|------------------------|------|-------|---|------------------------|------|-------|---|-------|---------------|
|                                 | Left                    | Thru | Right | U | Left                    | Thru | Right | U | Left                   | Thru | Right | U | Left                   | Thru | Right | U |       |               |
| 9:10 AM                         | 1                       | 0    | 1     | 0 | 0                       | 1    | 0     | 0 | 0                      | 0    | 0     | 0 | 0                      | 0    | 0     | 0 | 3     | 52            |
| 9:15 AM                         | 3                       | 0    | 1     | 0 | 0                       | 1    | 0     | 0 | 0                      | 0    | 0     | 0 | 2                      | 0    | 0     | 0 | 7     | 53            |
| 9:20 AM                         | 1                       | 1    | 0     | 0 | 0                       | 0    | 1     | 0 | 0                      | 0    | 0     | 1 | 2                      | 1    | 0     | 0 | 7     | 53            |
| 9:25 AM                         | 2                       | 1    | 0     | 0 | 0                       | 0    | 0     | 0 | 0                      | 0    | 0     | 0 | 0                      | 1    | 0     | 0 | 4     | 53            |
| 9:30 AM                         | 1                       | 0    | 1     | 0 | 0                       | 1    | 0     | 0 | 0                      | 0    | 0     | 0 | 0                      | 1    | 0     | 0 | 4     | 50            |
| 9:35 AM                         | 0                       | 1    | 0     | 0 | 0                       | 0    | 1     | 0 | 0                      | 0    | 0     | 1 | 1                      | 1    | 0     | 0 | 5     | 53            |
| 9:40 AM                         | 2                       | 0    | 1     | 0 | 0                       | 0    | 0     | 0 | 0                      | 0    | 0     | 0 | 0                      | 0    | 0     | 0 | 3     | 53            |
| 9:45 AM                         | 0                       | 1    | 0     | 0 | 0                       | 2    | 0     | 0 | 0                      | 0    | 0     | 0 | 1                      | 0    | 0     | 0 | 4     | 52            |
| 9:50 AM                         | 0                       | 0    | 1     | 0 | 0                       | 0    | 0     | 0 | 0                      | 0    | 1     | 1 | 0                      | 1    | 0     | 0 | 4     | 48            |
| 9:55 AM                         | 0                       | 0    | 0     | 0 | 0                       | 1    | 0     | 0 | 0                      | 0    | 0     | 0 | 0                      | 0    | 0     | 0 | 1     | 46            |
| 10:00 AM                        | 3                       | 1    | 1     | 0 | 0                       | 0    | 1     | 0 | 0                      | 0    | 0     | 3 | 0                      | 2    | 0     | 0 | 11    | 55            |
| 10:05 AM                        | 2                       | 0    | 0     | 0 | 0                       | 0    | 0     | 0 | 0                      | 0    | 0     | 2 | 0                      | 0    | 1     | 0 | 5     | 58            |
| 10:10 AM                        | 0                       | 0    | 1     | 0 | 0                       | 0    | 0     | 0 | 0                      | 0    | 0     | 0 | 0                      | 0    | 0     | 0 | 1     | 56            |
| 10:15 AM                        | 2                       | 0    | 0     | 0 | 0                       | 0    | 0     | 0 | 0                      | 1    | 1     | 2 | 0                      | 0    | 1     | 0 | 7     | 56            |
| 10:20 AM                        | 1                       | 1    | 0     | 0 | 0                       | 2    | 0     | 0 | 0                      | 0    | 0     | 0 | 0                      | 1    | 3     | 0 | 8     | 57            |
| 10:25 AM                        | 1                       | 0    | 0     | 0 | 0                       | 1    | 0     | 0 | 0                      | 0    | 0     | 0 | 0                      | 0    | 0     | 0 | 2     | 55            |
| 10:30 AM                        | 0                       | 0    | 0     | 0 | 0                       | 0    | 0     | 0 | 0                      | 0    | 0     | 1 | 0                      | 0    | 0     | 0 | 1     | 52            |
| 10:35 AM                        | 0                       | 0    | 2     | 0 | 0                       | 0    | 0     | 0 | 0                      | 0    | 0     | 0 | 0                      | 1    | 0     | 0 | 3     | 50            |
| 10:40 AM                        | 0                       | 0    | 0     | 0 | 0                       | 1    | 0     | 0 | 0                      | 0    | 0     | 0 | 0                      | 0    | 0     | 0 | 1     | 48            |
| 10:45 AM                        | 1                       | 0    | 0     | 0 | 0                       | 0    | 0     | 0 | 0                      | 0    | 2     | 1 | 0                      | 4    | 0     | 0 | 8     | 52            |
| 10:50 AM                        | 0                       | 0    | 0     | 0 | 0                       | 0    | 0     | 0 | 0                      | 0    | 0     | 0 | 0                      | 0    | 0     | 0 | 0     | 48            |
| 10:55 AM                        | 1                       | 2    | 2     | 0 | 0                       | 1    | 0     | 0 | 0                      | 0    | 0     | 1 | 0                      | 0    | 0     | 0 | 7     | 54            |
| 11:00 AM                        | 2                       | 1    | 0     | 0 | 0                       | 0    | 0     | 0 | 0                      | 0    | 0     | 0 | 0                      | 0    | 0     | 0 | 3     | 46            |
| 11:05 AM                        | 0                       | 0    | 0     | 0 | 0                       | 0    | 0     | 0 | 0                      | 1    | 0     | 0 | 0                      | 0    | 0     | 0 | 1     | 42            |
| 11:10 AM                        | 2                       | 1    | 0     | 0 | 0                       | 0    | 0     | 0 | 0                      | 0    | 0     | 0 | 0                      | 1    | 0     | 0 | 4     | 45            |
| 11:15 AM                        | 1                       | 3    | 0     | 0 | 0                       | 0    | 0     | 0 | 0                      | 0    | 0     | 1 | 0                      | 1    | 0     | 0 | 6     | 44            |
| 11:20 AM                        | 1                       | 0    | 0     | 0 | 0                       | 0    | 1     | 0 | 0                      | 0    | 0     | 1 | 0                      | 0    | 0     | 0 | 4     | 40            |
| 11:25 AM                        | 0                       | 1    | 1     | 0 | 0                       | 1    | 0     | 0 | 0                      | 0    | 0     | 0 | 0                      | 1    | 0     | 0 | 4     | 42            |
| 11:30 AM                        | 0                       | 0    | 0     | 0 | 0                       | 0    | 0     | 0 | 0                      | 0    | 0     | 1 | 0                      | 0    | 0     | 0 | 2     | 43            |
| 11:35 AM                        | 3                       | 1    | 1     | 0 | 0                       | 0    | 0     | 0 | 0                      | 0    | 0     | 0 | 0                      | 0    | 0     | 0 | 5     | 45            |
| 11:40 AM                        | 1                       | 0    | 0     | 0 | 0                       | 0    | 0     | 0 | 0                      | 0    | 0     | 0 | 0                      | 2    | 0     | 0 | 3     | 47            |
| 11:45 AM                        | 0                       | 0    | 2     | 0 | 0                       | 2    | 0     | 0 | 0                      | 0    | 0     | 0 | 0                      | 0    | 0     | 0 | 4     | 43            |
| 11:50 AM                        | 1                       | 2    | 2     | 0 | 0                       | 0    | 0     | 0 | 0                      | 0    | 0     | 0 | 0                      | 1    | 0     | 0 | 6     | 49            |
| 11:55 AM                        | 0                       | 0    | 0     | 0 | 0                       | 0    | 1     | 0 | 0                      | 1    | 0     | 0 | 0                      | 1    | 0     | 0 | 3     | 45            |
| 12:00 PM                        | 0                       | 1    | 0     | 0 | 0                       | 0    | 0     | 0 | 0                      | 0    | 0     | 1 | 0                      | 2    | 0     | 0 | 4     | 46            |
| 12:05 PM                        | 1                       | 1    | 2     | 0 | 0                       | 0    | 0     | 0 | 0                      | 0    | 1     | 0 | 0                      | 0    | 0     | 0 | 5     | 50            |
| 12:10 PM                        | 1                       | 1    | 1     | 0 | 0                       | 1    | 0     | 0 | 0                      | 0    | 0     | 0 | 0                      | 1    | 0     | 0 | 5     | 51            |
| 12:15 PM                        | 1                       | 0    | 1     | 0 | 0                       | 0    | 1     | 0 | 0                      | 0    | 1     | 0 | 0                      | 0    | 0     | 0 | 4     | 49            |
| 12:20 PM                        | 2                       | 0    | 0     | 0 | 0                       | 0    | 0     | 0 | 0                      | 0    | 0     | 0 | 0                      | 0    | 0     | 0 | 2     | 47            |
| 12:25 PM                        | 0                       | 2    | 0     | 0 | 0                       | 0    | 0     | 0 | 0                      | 0    | 2     | 1 | 0                      | 0    | 0     | 0 | 5     | 48            |
| 12:30 PM                        | 2                       | 0    | 0     | 0 | 0                       | 0    | 0     | 0 | 0                      | 0    | 0     | 0 | 0                      | 4    | 0     | 0 | 6     | 52            |
| 12:35 PM                        | 2                       | 0    | 0     | 0 | 0                       | 0    | 0     | 0 | 0                      | 0    | 0     | 2 | 0                      | 1    | 0     | 0 | 5     | 52            |
| 12:40 PM                        | 2                       | 0    | 1     | 0 | 0                       | 2    | 1     | 0 | 0                      | 1    | 3     | 0 | 0                      | 0    | 0     | 0 | 10    | 59            |
| 12:45 PM                        | 2                       | 1    | 0     | 0 | 0                       | 0    | 1     | 0 | 0                      | 0    | 0     | 1 | 0                      | 2    | 0     | 0 | 7     | 62            |
| 12:50 PM                        | 1                       | 0    | 0     | 0 | 0                       | 1    | 0     | 0 | 0                      | 1    | 0     | 0 | 0                      | 0    | 0     | 0 | 3     | 59            |
| 12:55 PM                        | 1                       | 2    | 1     | 0 | 0                       | 0    | 0     | 0 | 0                      | 1    | 1     | 0 | 0                      | 1    | 0     | 0 | 7     | 63            |
| 1:00 PM                         | 1                       | 0    | 1     | 0 | 0                       | 0    | 1     | 0 | 0                      | 0    | 3     | 0 | 0                      | 0    | 1     | 0 | 7     | 66            |
| 1:05 PM                         | 1                       | 1    | 0     | 0 | 0                       | 0    | 0     | 0 | 0                      | 1    | 0     | 1 | 0                      | 0    | 1     | 0 | 5     | 66            |
| 1:10 PM                         | 0                       | 1    | 0     | 0 | 0                       | 0    | 0     | 0 | 0                      | 0    | 0     | 2 | 0                      | 1    | 1     | 0 | 5     | 66            |
| 1:15 PM                         | 1                       | 1    | 2     | 0 | 0                       | 0    | 0     | 0 | 0                      | 0    | 0     | 0 | 0                      | 0    | 0     | 0 | 4     | 66            |
| 1:20 PM                         | 2                       | 0    | 1     | 0 | 0                       | 1    | 0     | 0 | 0                      | 0    | 1     | 0 | 0                      | 2    | 0     | 0 | 7     | 71            |
| 1:25 PM                         | 2                       | 0    | 1     | 0 | 0                       | 1    | 0     | 0 | 0                      | 0    | 1     | 0 | 0                      | 1    | 1     | 0 | 7     | 73            |
| 1:30 PM                         | 1                       | 0    | 0     | 0 | 0                       | 0    | 0     | 0 | 0                      | 0    | 0     | 1 | 0                      | 1    | 0     | 0 | 4     | 71            |
| 1:35 PM                         | 2                       | 3    | 1     | 0 | 0                       | 0    | 0     | 0 | 0                      | 0    | 1     | 0 | 0                      | 0    | 0     | 0 | 7     | 73            |
| 1:40 PM                         | 2                       | 3    | 0     | 0 | 0                       | 0    | 1     | 0 | 0                      | 0    | 1     | 0 | 0                      | 1    | 0     | 0 | 8     | 71            |
| 1:45 PM                         | 1                       | 0    | 0     | 0 | 0                       | 0    | 0     | 0 | 0                      | 0    | 0     | 0 | 0                      | 0    | 0     | 0 | 1     | 65            |
| 1:50 PM                         | 1                       | 0    | 1     | 0 | 0                       | 0    | 0     | 0 | 0                      | 0    | 0     | 1 | 0                      | 1    | 0     | 0 | 4     | 66            |
| 1:55 PM                         | 1                       | 2    | 0     | 0 | 0                       | 0    | 0     | 0 | 0                      | 0    | 0     | 0 | 0                      | 0    | 0     | 0 | 3     | 62            |
| 2:00 PM                         | 1                       | 0    | 0     | 0 | 0                       | 0    | 0     | 0 | 0                      | 0    | 0     | 0 | 0                      | 1    | 0     | 0 | 2     | 57            |
| 2:05 PM                         | 2                       | 0    | 0     | 0 | 0                       | 1    | 0     | 0 | 0                      | 1    | 0     | 0 | 0                      | 0    | 1     | 0 | 5     | 57            |
| 2:10 PM                         | 0                       | 0    | 1     | 0 | 0                       | 0    | 0     | 0 | 0                      | 0    | 1     | 0 | 0                      | 0    | 2     | 0 | 4     | 56            |
| 2:15 PM                         | 2                       | 0    | 1     | 0 | 0                       | 0    | 0     | 0 | 0                      | 0    | 0     | 0 | 0                      | 0    | 0     | 0 | 3     | 55            |
| 2:20 PM                         | 2                       | 1    | 0     | 0 | 0                       | 0    | 0     | 0 | 0                      | 0    | 1     | 1 | 0                      | 0    | 1     | 0 | 6     | 54            |
| 2:25 PM                         | 2                       | 0    | 1     | 0 | 0                       | 0    | 0     | 0 | 0                      | 1    | 1     | 0 | 0                      | 0    | 1     | 0 | 6     | 53            |
| 2:30 PM                         | 4                       | 1    | 2     | 0 | 0                       | 1    | 0     | 0 | 0                      | 0    | 1     | 0 | 0                      | 0    | 1     | 0 | 10    | 59            |
| 2:35 PM                         | 1                       | 1    | 1     | 0 | 0                       | 0    | 0     | 0 | 0                      | 0    | 2     | 0 | 0                      | 0    | 0     | 2 | 7     | 59            |
| 2:40 PM                         | 0                       | 0    | 0     | 0 | 0                       | 1    | 0     | 0 | 0                      | 0    | 0     | 0 | 0                      | 2    | 0     | 0 | 3     | 54            |
| 2:45 PM                         | 1                       | 0    | 0     | 0 | 0                       | 0    | 0     | 0 | 0                      | 0    | 0     | 0 | 0                      | 0    | 1     | 0 | 2     | 55            |
| 2:50 PM                         | 2                       | 1    | 2     | 0 | 0                       | 0    | 0     | 0 | 0                      | 0    | 0     | 0 | 0                      | 0    | 0     | 0 | 5     | 56            |
| 2:55 PM                         | 0                       | 1    | 1     | 0 | 0                       | 0    | 0     | 0 | 0                      | 0    | 1     | 1 | 0                      | 0    | 0     | 0 | 4     | 57            |
| 3:00 PM                         | 0                       | 0    | 0     | 0 | 0                       | 0    | 0     | 0 | 0                      | 0    | 2     | 0 | 0                      | 0    | 1     | 0 | 3     | 58            |
| 3:05 PM                         | 2                       | 1    | 0     | 0 | 0                       | 0    | 0     | 0 | 0                      | 1    | 0     | 2 | 0                      | 0    | 1     | 0 | 7     | 60            |
| 3:10 PM                         | 1                       | 0    | 0     | 0 | 0                       | 0    | 1     | 0 | 0                      | 0    | 1     | 0 | 0                      | 0    | 1     | 0 | 4     | 60            |
| 3:15 PM                         | 3                       | 0    | 0     | 0 | 0                       | 0    | 0     | 0 | 0                      | 0    | 2     | 0 | 0                      | 0    | 0     | 0 | 5     | 62            |
| 3:20 PM                         | 1                       | 2    | 2     | 0 | 0                       | 0    | 0     | 0 | 0                      | 0    | 1     | 0 | 0                      | 1    | 0     | 0 | 7     | 63            |
| 3:25 PM                         | 2                       | 0    | 1     | 0 | 0                       | 0    | 0     | 0 | 0                      | 1    | 0     | 0 | 0                      | 0    | 2     | 0 | 6     | 63            |
| 3:30 PM                         | 1                       | 0    | 0     | 0 | 0                       | 0    | 1     | 0 | 0                      | 0    | 3     | 1 | 0                      | 0    | 1     | 0 | 7     | 60            |
| 3:35 PM                         | 1                       | 0    | 1     | 0 | 0                       | 1    | 0     | 0 | 0                      | 1    | 0     | 1 | 0                      | 2    | 0     | 0 | 7     | 60            |
| 3:40 PM                         | 1                       | 0    | 1     | 0 | 0                       | 1    | 0     | 0 | 0                      | 0    | 0     | 0 | 0                      | 0    | 0     | 0 | 3     | 60            |
| 3:45 PM                         | 3                       | 1    | 0     | 0 | 0                       | 0    | 0     | 0 | 0                      | 0    | 1     | 3 | 0                      | 0    | 0     | 0 | 8     | 66            |
| 3:50 PM                         | 1                       | 1    | 1     | 0 | 0                       | 0    | 0     | 0 | 0                      | 0    | 0     | 3 | 0                      | 0    | 0     | 0 | 6     | 67            |
| 3:55 PM                         | 2                       | 0    | 2     | 0 | 0                       | 2    | 0     | 0 | 0                      | 0    | 0     | 3 | 0                      | 1    | 0     | 0 | 10    | 73            |
| 4:00 PM                         | 2                       | 0    | 1     | 0 | 0                       | 1    | 0     | 0 | 0                      | 0    | 0     | 0 | 0                      | 0    | 2     | 0 | 6     | 76            |
| 4:05 PM                         | 1                       | 1    | 4     | 0 | 0                       | 0    | 0     | 0 | 0                      | 0    | 0     | 1 | 0                      | 0    | 0     | 0 | 7     | 76            |
| 4:10 PM                         | 1                       | 1    | 1     | 0 | 0                       | 0    | 1     | 0 | 0                      | 0    | 0     | 0 | 0                      | 0    | 1     | 0 | 5     | 77            |
| 4:15 PM                         | 0                       | 0    | 3     | 0 | 0                       | 1    | 0     | 0 | 0                      | 0    | 1     | 2 | 0                      | 0    | 3     | 0 | 10    | 82            |
| 4:20 PM                         | 3                       | 0    | 0     | 0 | 0                       | 0    | 1     | 0 | 0                      | 0    | 1     | 0 | 0                      | 1    | 1     | 0 | 7     | 82            |
| 4:25 PM                         | 0                       | 1    | 0     | 0 | 0                       | 0    | 0     | 0 | 0                      | 0    | 0     | 0 | 0                      | 0    | 1     | 0 | 2     | 78            |
| 4:30 PM                         | 3                       | 1    | 1     | 0 | 0                       | 1    | 0     | 0 | 0                      | 0    | 2     | 1 | 0                      | 0    | 0     | 0 | 9     | 80            |

Attachment B

| 5-Min Count Period Beginning At | Antigua St (Northbound) |      |       |   | Antigua St (Southbound) |      |       |   | Guinida Ln (Eastbound) |      |       |   | Guinida Ln (Westbound) |      |       |   | Total | Hourly Totals |
|---------------------------------|-------------------------|------|-------|---|-------------------------|------|-------|---|------------------------|------|-------|---|------------------------|------|-------|---|-------|---------------|
|                                 | Left                    | Thru | Right | U | Left                    | Thru | Right | U | Left                   | Thru | Right | U | Left                   | Thru | Right | U |       |               |
| 4:35 PM                         | 1                       | 1    | 1     | 0 | 0                       | 0    | 0     | 0 | 0                      | 0    | 0     | 0 | 0                      | 0    | 1     | 0 | 4     | 77            |
| 4:40 PM                         | 2                       | 3    | 1     | 0 | 0                       | 0    | 0     | 0 | 1                      | 0    | 1     | 0 | 0                      | 1    | 0     | 0 | 9     | 83            |
| 4:45 PM                         | 4                       | 0    | 0     | 0 | 0                       | 0    | 0     | 0 | 1                      | 1    | 1     | 0 | 0                      | 1    | 0     | 0 | 8     | 83            |
| 4:50 PM                         | 2                       | 0    | 0     | 0 | 0                       | 1    | 0     | 0 | 2                      | 0    | 0     | 0 | 0                      | 1    | 0     | 0 | 6     | 83            |
| 4:55 PM                         | 0                       | 1    | 1     | 0 | 0                       | 0    | 1     | 0 | 0                      | 1    | 0     | 0 | 1                      | 0    | 0     | 0 | 5     | 78            |
| 5:00 PM                         | 0                       | 1    | 0     | 0 | 0                       | 1    | 0     | 0 | 0                      | 4    | 0     | 0 | 0                      | 0    | 0     | 0 | 6     | 78            |
| 5:05 PM                         | 0                       | 4    | 3     | 0 | 0                       | 0    | 0     | 0 | 1                      | 1    | 0     | 0 | 0                      | 1    | 0     | 0 | 10    | 81            |
| 5:10 PM                         | 3                       | 1    | 0     | 0 | 0                       | 1    | 0     | 0 | 0                      | 0    | 0     | 0 | 0                      | 2    | 0     | 0 | 7     | 83            |
| 5:15 PM                         | 2                       | 4    | 0     | 0 | 0                       | 1    | 2     | 0 | 0                      | 0    | 1     | 0 | 0                      | 0    | 0     | 0 | 10    | 83            |
| 5:20 PM                         | 2                       | 1    | 1     | 0 | 0                       | 0    | 0     | 0 | 0                      | 0    | 1     | 0 | 1                      | 1    | 0     | 0 | 7     | 83            |
| 5:25 PM                         | 3                       | 1    | 0     | 0 | 1                       | 0    | 0     | 0 | 1                      | 0    | 1     | 0 | 0                      | 0    | 0     | 0 | 7     | 88            |
| 5:30 PM                         | 1                       | 0    | 2     | 0 | 0                       | 1    | 0     | 0 | 0                      | 0    | 0     | 0 | 0                      | 1    | 0     | 0 | 5     | 84            |
| 5:35 PM                         | 1                       | 5    | 2     | 0 | 0                       | 1    | 1     | 0 | 1                      | 1    | 0     | 0 | 1                      | 1    | 0     | 0 | 14    | 94            |
| 5:40 PM                         | 1                       | 1    | 2     | 0 | 0                       | 0    | 1     | 0 | 0                      | 4    | 1     | 0 | 1                      | 1    | 0     | 0 | 12    | 97            |
| 5:45 PM                         | 4                       | 1    | 1     | 0 | 0                       | 2    | 1     | 0 | 0                      | 0    | 0     | 0 | 1                      | 0    | 0     | 0 | 10    | 99            |
| 5:50 PM                         | 2                       | 1    | 1     | 0 | 0                       | 0    | 1     | 0 | 0                      | 0    | 0     | 0 | 0                      | 0    | 0     | 0 | 5     | 98            |
| 5:55 PM                         | 2                       | 0    | 0     | 0 | 0                       | 1    | 1     | 0 | 0                      | 3    | 0     | 0 | 1                      | 0    | 0     | 0 | 8     | 101           |
| 6:00 PM                         | 0                       | 0    | 4     | 0 | 0                       | 0    | 0     | 0 | 0                      | 0    | 0     | 0 | 0                      | 2    | 0     | 0 | 6     | 101           |
| 6:05 PM                         | 1                       | 2    | 1     | 0 | 0                       | 1    | 0     | 0 | 0                      | 1    | 1     | 0 | 0                      | 0    | 0     | 0 | 7     | 98            |
| 6:10 PM                         | 3                       | 0    | 1     | 0 | 0                       | 0    | 0     | 0 | 0                      | 0    | 1     | 0 | 0                      | 0    | 0     | 0 | 5     | 96            |
| 6:15 PM                         | 3                       | 0    | 1     | 0 | 0                       | 1    | 0     | 0 | 0                      | 0    | 1     | 0 | 0                      | 0    | 0     | 0 | 6     | 92            |
| 6:20 PM                         | 2                       | 0    | 3     | 0 | 0                       | 0    | 0     | 0 | 0                      | 1    | 1     | 0 | 1                      | 1    | 0     | 0 | 9     | 94            |
| 6:25 PM                         | 0                       | 0    | 0     | 0 | 0                       | 1    | 1     | 0 | 0                      | 0    | 0     | 0 | 0                      | 1    | 0     | 0 | 3     | 90            |
| 6:30 PM                         | 1                       | 0    | 0     | 0 | 0                       | 1    | 0     | 0 | 1                      | 0    | 0     | 0 | 0                      | 0    | 0     | 0 | 3     | 88            |
| 6:35 PM                         | 1                       | 1    | 1     | 0 | 1                       | 0    | 0     | 0 | 0                      | 0    | 1     | 0 | 0                      | 0    | 0     | 0 | 5     | 79            |
| 6:40 PM                         | 0                       | 1    | 1     | 0 | 0                       | 0    | 0     | 0 | 0                      | 1    | 0     | 0 | 0                      | 0    | 0     | 0 | 3     | 70            |
| 6:45 PM                         | 0                       | 0    | 0     | 0 | 0                       | 1    | 0     | 0 | 1                      | 0    | 0     | 0 | 0                      | 0    | 0     | 0 | 2     | 62            |
| 6:50 PM                         | 2                       | 0    | 2     | 0 | 0                       | 0    | 0     | 0 | 0                      | 0    | 0     | 0 | 1                      | 0    | 0     | 0 | 5     | 62            |
| 6:55 PM                         | 3                       | 1    | 0     | 0 | 0                       | 1    | 0     | 0 | 1                      | 0    | 0     | 0 | 0                      | 2    | 0     | 0 | 8     | 62            |
| 7:00 PM                         | 0                       | 2    | 1     | 0 | 0                       | 0    | 0     | 0 | 0                      | 1    | 0     | 0 | 0                      | 0    | 0     | 0 | 4     | 60            |
| 7:05 PM                         | 2                       | 0    | 0     | 0 | 0                       | 2    | 0     | 0 | 1                      | 4    | 0     | 0 | 0                      | 2    | 1     | 0 | 12    | 65            |
| 7:10 PM                         | 0                       | 0    | 0     | 0 | 0                       | 1    | 0     | 0 | 1                      | 0    | 0     | 0 | 0                      | 0    | 0     | 0 | 2     | 62            |
| 7:15 PM                         | 1                       | 1    | 2     | 0 | 0                       | 1    | 1     | 0 | 0                      | 1    | 0     | 0 | 0                      | 1    | 0     | 0 | 8     | 64            |
| 7:20 PM                         | 0                       | 1    | 1     | 0 | 0                       | 0    | 0     | 0 | 0                      | 2    | 0     | 0 | 0                      | 0    | 0     | 0 | 4     | 59            |
| 7:25 PM                         | 2                       | 0    | 2     | 0 | 0                       | 0    | 0     | 0 | 0                      | 1    | 0     | 0 | 0                      | 0    | 0     | 0 | 5     | 61            |
| 7:30 PM                         | 1                       | 0    | 1     | 0 | 0                       | 0    | 0     | 0 | 0                      | 0    | 1     | 0 | 0                      | 0    | 0     | 0 | 3     | 61            |
| 7:35 PM                         | 1                       | 1    | 1     | 0 | 0                       | 0    | 0     | 0 | 0                      | 2    | 0     | 0 | 0                      | 1    | 0     | 0 | 6     | 62            |
| 7:40 PM                         | 0                       | 1    | 2     | 0 | 0                       | 0    | 0     | 0 | 0                      | 2    | 0     | 0 | 0                      | 1    | 0     | 0 | 6     | 65            |
| 7:45 PM                         | 0                       | 2    | 0     | 0 | 0                       | 1    | 0     | 0 | 0                      | 2    | 0     | 0 | 0                      | 0    | 0     | 0 | 5     | 68            |
| 7:50 PM                         | 0                       | 0    | 0     | 0 | 0                       | 0    | 0     | 0 | 0                      | 1    | 1     | 0 | 1                      | 0    | 0     | 0 | 3     | 66            |
| 7:55 PM                         | 2                       | 1    | 3     | 0 | 0                       | 0    | 2     | 0 | 0                      | 0    | 1     | 0 | 1                      | 1    | 0     | 0 | 11    | 69            |
| 8:00 PM                         | 5                       | 1    | 0     | 0 | 0                       | 1    | 0     | 0 | 0                      | 0    | 0     | 0 | 1                      | 1    | 0     | 0 | 9     | 74            |
| 8:05 PM                         | 3                       | 1    | 0     | 0 | 0                       | 1    | 0     | 0 | 0                      | 1    | 0     | 0 | 0                      | 0    | 0     | 0 | 6     | 68            |
| 8:10 PM                         | 3                       | 1    | 0     | 0 | 0                       | 0    | 0     | 0 | 1                      | 1    | 0     | 0 | 0                      | 1    | 0     | 0 | 7     | 73            |
| 8:15 PM                         | 2                       | 0    | 2     | 0 | 0                       | 0    | 0     | 0 | 0                      | 0    | 0     | 0 | 0                      | 1    | 0     | 0 | 5     | 70            |
| 8:20 PM                         | 2                       | 0    | 1     | 0 | 1                       | 0    | 0     | 0 | 0                      | 0    | 0     | 0 | 0                      | 2    | 0     | 0 | 6     | 72            |
| 8:25 PM                         | 1                       | 0    | 0     | 0 | 0                       | 0    | 0     | 0 | 0                      | 1    | 1     | 0 | 0                      | 0    | 0     | 0 | 3     | 70            |
| 8:30 PM                         | 1                       | 0    | 0     | 0 | 0                       | 0    | 0     | 0 | 0                      | 1    | 0     | 0 | 0                      | 0    | 0     | 0 | 2     | 69            |
| 8:35 PM                         | 0                       | 0    | 0     | 0 | 0                       | 0    | 0     | 0 | 0                      | 0    | 0     | 0 | 0                      | 1    | 0     | 0 | 1     | 64            |
| 8:40 PM                         | 0                       | 1    | 0     | 0 | 0                       | 0    | 0     | 0 | 1                      | 0    | 1     | 0 | 0                      | 0    | 0     | 0 | 3     | 61            |
| 8:45 PM                         | 0                       | 1    | 1     | 0 | 0                       | 1    | 0     | 0 | 0                      | 1    | 0     | 0 | 0                      | 0    | 0     | 0 | 4     | 60            |
| 8:50 PM                         | 2                       | 0    | 0     | 0 | 0                       | 0    | 0     | 0 | 1                      | 1    | 3     | 0 | 0                      | 0    | 0     | 0 | 7     | 64            |
| 8:55 PM                         | 3                       | 1    | 2     | 0 | 0                       | 0    | 0     | 0 | 0                      | 3    | 1     | 0 | 0                      | 1    | 0     | 0 | 11    | 64            |
| 9:00 PM                         | 0                       | 1    | 1     | 0 | 0                       | 0    | 1     | 0 | 0                      | 1    | 0     | 0 | 0                      | 2    | 1     | 0 | 7     | 62            |
| 9:05 PM                         | 0                       | 0    | 2     | 0 | 0                       | 0    | 0     | 0 | 0                      | 0    | 0     | 0 | 0                      | 0    | 0     | 0 | 2     | 58            |
| 9:10 PM                         | 0                       | 1    | 0     | 0 | 0                       | 0    | 0     | 0 | 0                      | 0    | 0     | 0 | 0                      | 1    | 0     | 0 | 2     | 53            |
| 9:15 PM                         | 1                       | 0    | 1     | 0 | 0                       | 0    | 1     | 0 | 0                      | 0    | 0     | 0 | 1                      | 0    | 0     | 0 | 4     | 52            |
| 9:20 PM                         | 0                       | 0    | 2     | 0 | 0                       | 0    | 0     | 0 | 0                      | 2    | 0     | 0 | 1                      | 1    | 0     | 0 | 6     | 52            |
| 9:25 PM                         | 2                       | 0    | 0     | 0 | 0                       | 0    | 0     | 0 | 0                      | 0    | 2     | 0 | 0                      | 1    | 0     | 0 | 5     | 54            |
| 9:30 PM                         | 1                       | 0    | 1     | 0 | 0                       | 0    | 0     | 0 | 0                      | 0    | 0     | 0 | 0                      | 0    | 0     | 0 | 2     | 54            |
| 9:35 PM                         | 1                       | 0    | 1     | 0 | 0                       | 0    | 0     | 0 | 0                      | 0    | 1     | 0 | 0                      | 0    | 0     | 0 | 3     | 56            |
| 9:40 PM                         | 0                       | 0    | 2     | 0 | 0                       | 0    | 0     | 0 | 0                      | 0    | 0     | 0 | 0                      | 0    | 0     | 0 | 2     | 55            |
| 9:45 PM                         | 1                       | 1    | 0     | 0 | 0                       | 1    | 0     | 0 | 0                      | 0    | 0     | 0 | 0                      | 0    | 0     | 0 | 3     | 54            |
| 9:50 PM                         | 0                       | 0    | 0     | 0 | 0                       | 0    | 0     | 0 | 0                      | 2    | 0     | 0 | 0                      | 0    | 0     | 0 | 2     | 49            |
| 9:55 PM                         | 2                       | 0    | 0     | 0 | 0                       | 0    | 1     | 0 | 0                      | 0    | 0     | 0 | 0                      | 1    | 0     | 0 | 4     | 42            |
| Peak 15-Min Flowrates           | Northbound              |      |       |   | Southbound              |      |       |   | Eastbound              |      |       |   | Westbound              |      |       |   | Total |               |
|                                 | Left                    | Thru | Right | U | Left                    | Thru | Right | U | Left                   | Thru | Right | U | Left                   | Thru | Right | U |       |               |
| All Vehicles                    | 24                      | 28   | 20    | 0 | 0                       | 12   | 12    | 0 | 4                      | 20   | 4     | 0 | 12                     | 8    | 0     | 0 | 144   |               |
| Heavy Trucks                    | 0                       | 0    | 0     | 0 | 0                       | 0    | 0     | 0 | 0                      | 0    | 0     | 0 | 0                      | 0    | 0     | 0 | 0     |               |
| Buses                           |                         |      |       |   |                         |      |       |   |                        |      |       |   |                        |      |       |   |       |               |
| Pedestrians                     |                         | 4    |       |   |                         | 0    |       |   |                        | 4    |       |   |                        | 12   |       |   | 20    |               |
| Bicycles                        | 0                       | 0    | 0     |   | 0                       | 0    | 0     |   | 0                      | 0    | 0     |   | 0                      | 0    | 4     |   | 4     |               |
| Scoters                         |                         |      |       |   |                         |      |       |   |                        |      |       |   |                        |      |       |   |       |               |

Comments:

LOCATION: Gravier St -- Bienville Ave  
 CITY/STATE: Orange, CA

QC JOB #: 16966429  
 DATE: Wed, Apr 9 2025

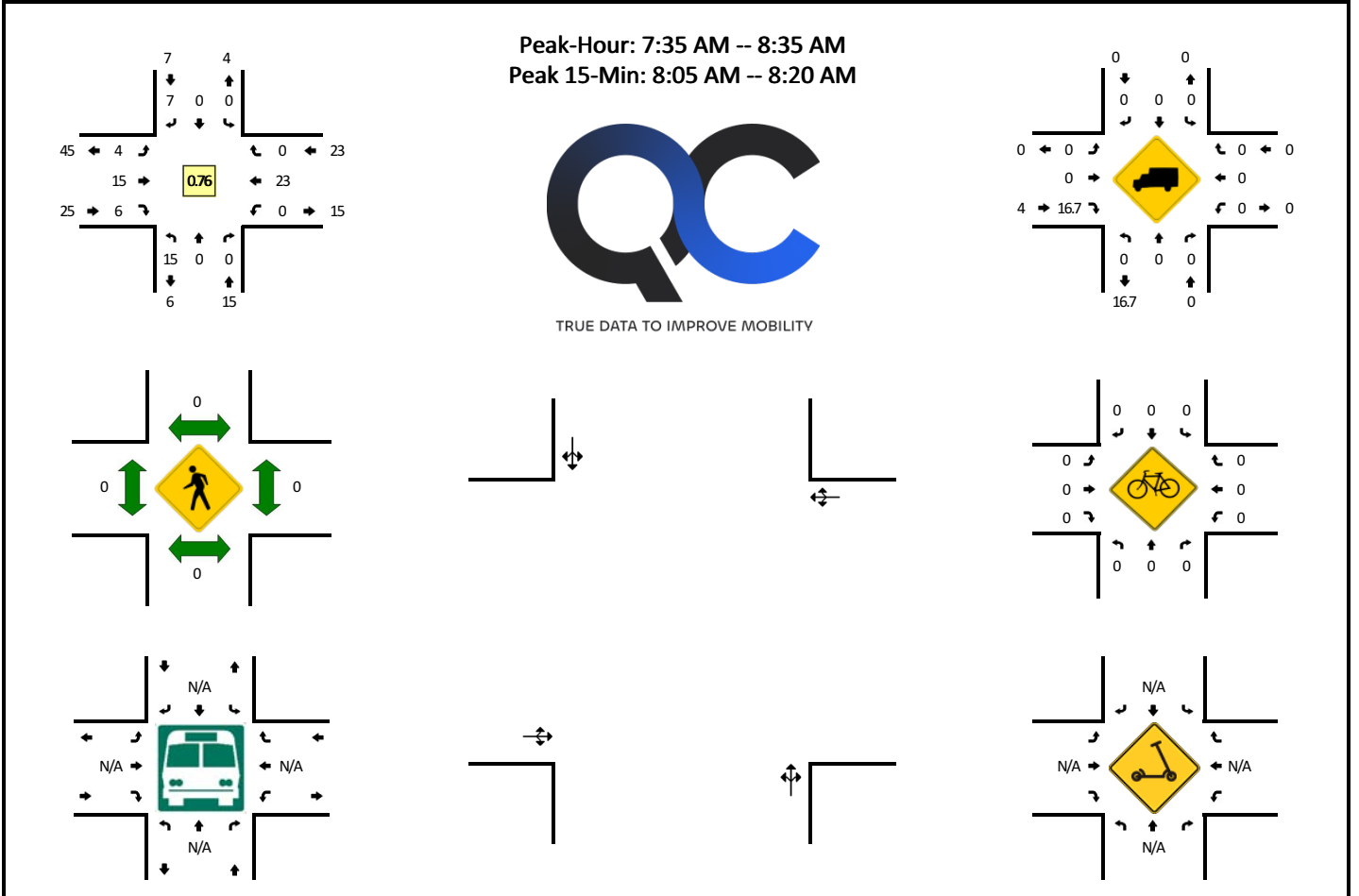

| 5-Min Count Period Beginning At | Gravier St (Northbound) |      |       |   | Gravier St (Southbound) |      |       |   | Bienville Ave (Eastbound) |      |       |   | Bienville Ave (Westbound) |      |       |   | Total | Hourly Totals |    |
|---------------------------------|-------------------------|------|-------|---|-------------------------|------|-------|---|---------------------------|------|-------|---|---------------------------|------|-------|---|-------|---------------|----|
|                                 | Left                    | Thru | Right | U | Left                    | Thru | Right | U | Left                      | Thru | Right | U | Left                      | Thru | Right | U |       |               |    |
| 6:00 AM                         | 1                       | 0    | 0     | 0 | 0                       | 0    | 0     | 0 | 0                         | 0    | 0     | 0 | 0                         | 2    | 0     | 0 | 0     | 3             |    |
| 6:05 AM                         | 1                       | 0    | 0     | 0 | 0                       | 0    | 0     | 0 | 0                         | 0    | 0     | 0 | 0                         | 1    | 0     | 0 | 0     | 2             |    |
| 6:10 AM                         | 1                       | 0    | 0     | 0 | 0                       | 0    | 0     | 0 | 0                         | 0    | 0     | 0 | 0                         | 0    | 0     | 0 | 0     | 1             |    |
| 6:15 AM                         | 0                       | 0    | 0     | 0 | 0                       | 0    | 0     | 0 | 0                         | 0    | 0     | 0 | 0                         | 2    | 0     | 0 | 0     | 2             |    |
| 6:20 AM                         | 1                       | 0    | 0     | 0 | 0                       | 0    | 0     | 0 | 0                         | 0    | 0     | 0 | 0                         | 2    | 0     | 0 | 0     | 3             |    |
| 6:25 AM                         | 0                       | 0    | 0     | 0 | 0                       | 0    | 0     | 0 | 0                         | 0    | 2     | 1 | 0                         | 0    | 1     | 0 | 0     | 4             |    |
| 6:30 AM                         | 0                       | 0    | 0     | 0 | 0                       | 0    | 0     | 0 | 0                         | 0    | 0     | 1 | 0                         | 0    | 1     | 0 | 0     | 2             |    |
| 6:35 AM                         | 0                       | 0    | 0     | 0 | 0                       | 0    | 2     | 0 | 0                         | 0    | 0     | 0 | 0                         | 3    | 0     | 0 | 0     | 5             |    |
| 6:40 AM                         | 0                       | 0    | 0     | 0 | 0                       | 0    | 0     | 0 | 0                         | 0    | 0     | 0 | 0                         | 1    | 0     | 0 | 0     | 1             |    |
| 6:45 AM                         | 1                       | 0    | 0     | 0 | 0                       | 0    | 0     | 0 | 0                         | 0    | 2     | 1 | 0                         | 0    | 0     | 0 | 0     | 4             |    |
| 6:50 AM                         | 2                       | 0    | 0     | 0 | 0                       | 0    | 1     | 0 | 0                         | 0    | 1     | 1 | 0                         | 0    | 2     | 0 | 0     | 7             |    |
| 6:55 AM                         | 2                       | 0    | 0     | 0 | 0                       | 0    | 0     | 0 | 0                         | 0    | 0     | 0 | 0                         | 1    | 0     | 0 | 0     | 3             | 37 |
| 7:00 AM                         | 0                       | 0    | 0     | 0 | 0                       | 0    | 0     | 0 | 0                         | 0    | 0     | 0 | 0                         | 0    | 0     | 0 | 0     | 0             | 34 |
| 7:05 AM                         | 1                       | 0    | 0     | 0 | 0                       | 0    | 0     | 0 | 0                         | 0    | 1     | 0 | 0                         | 0    | 2     | 0 | 0     | 4             | 36 |
| 7:10 AM                         | 2                       | 0    | 0     | 0 | 0                       | 0    | 1     | 0 | 0                         | 0    | 0     | 0 | 0                         | 1    | 0     | 0 | 0     | 4             | 39 |
| 7:15 AM                         | 0                       | 0    | 0     | 0 | 0                       | 0    | 0     | 0 | 0                         | 1    | 0     | 0 | 0                         | 1    | 0     | 0 | 0     | 2             | 39 |
| 7:20 AM                         | 0                       | 0    | 0     | 0 | 0                       | 0    | 0     | 0 | 0                         | 0    | 0     | 0 | 0                         | 2    | 0     | 0 | 0     | 2             | 38 |
| 7:25 AM                         | 3                       | 0    | 0     | 0 | 0                       | 0    | 0     | 0 | 0                         | 0    | 0     | 1 | 0                         | 1    | 0     | 0 | 0     | 5             | 39 |
| 7:30 AM                         | 0                       | 0    | 0     | 0 | 0                       | 0    | 0     | 0 | 0                         | 0    | 0     | 0 | 0                         | 0    | 0     | 0 | 0     | 0             | 37 |
| 7:35 AM                         | 0                       | 0    | 0     | 0 | 0                       | 0    | 2     | 0 | 0                         | 0    | 0     | 0 | 0                         | 2    | 0     | 0 | 0     | 4             | 36 |
| 7:40 AM                         | 4                       | 0    | 0     | 0 | 0                       | 0    | 1     | 0 | 0                         | 0    | 1     | 0 | 0                         | 4    | 0     | 0 | 0     | 10            | 45 |
| 7:45 AM                         | 1                       | 0    | 0     | 0 | 0                       | 0    | 1     | 0 | 0                         | 0    | 2     | 0 | 0                         | 2    | 0     | 0 | 0     | 6             | 47 |
| 7:50 AM                         | 1                       | 0    | 0     | 0 | 0                       | 0    | 0     | 0 | 0                         | 0    | 2     | 1 | 0                         | 2    | 0     | 0 | 0     | 6             | 46 |
| 7:55 AM                         | 0                       | 0    | 0     | 0 | 0                       | 0    | 0     | 0 | 0                         | 0    | 1     | 1 | 0                         | 4    | 0     | 0 | 0     | 6             | 49 |
| 8:00 AM                         | 1                       | 0    | 0     | 0 | 0                       | 0    | 0     | 0 | 0                         | 0    | 1     | 0 | 0                         | 0    | 0     | 0 | 0     | 2             | 51 |
| 8:05 AM                         | 1                       | 0    | 0     | 0 | 0                       | 0    | 1     | 0 | 0                         | 0    | 2     | 0 | 0                         | 2    | 0     | 0 | 0     | 6             | 53 |
| 8:10 AM                         | 1                       | 0    | 0     | 0 | 0                       | 0    | 0     | 0 | 0                         | 0    | 2     | 1 | 0                         | 1    | 0     | 0 | 0     | 5             | 54 |
| 8:15 AM                         | 4                       | 0    | 0     | 0 | 0                       | 0    | 1     | 0 | 0                         | 1    | 1     | 2 | 0                         | 3    | 0     | 0 | 0     | 12            | 64 |
| 8:20 AM                         | 0                       | 0    | 0     | 0 | 0                       | 0    | 1     | 0 | 0                         | 1    | 1     | 0 | 0                         | 1    | 0     | 0 | 0     | 4             | 66 |
| 8:25 AM                         | 1                       | 0    | 0     | 0 | 0                       | 0    | 0     | 0 | 0                         | 1    | 0     | 0 | 0                         | 1    | 0     | 0 | 0     | 3             | 64 |
| 8:30 AM                         | 1                       | 0    | 0     | 0 | 0                       | 0    | 0     | 0 | 0                         | 1    | 2     | 1 | 0                         | 0    | 1     | 0 | 0     | 6             | 70 |
| 8:35 AM                         | 1                       | 0    | 0     | 0 | 0                       | 0    | 0     | 0 | 0                         | 0    | 1     | 1 | 0                         | 0    | 1     | 0 | 0     | 4             | 70 |
| 8:40 AM                         | 1                       | 0    | 0     | 0 | 0                       | 0    | 0     | 0 | 0                         | 0    | 1     | 1 | 0                         | 0    | 0     | 0 | 0     | 3             | 63 |
| 8:45 AM                         | 2                       | 0    | 0     | 0 | 0                       | 0    | 0     | 0 | 0                         | 0    | 0     | 1 | 0                         | 1    | 0     | 0 | 0     | 4             | 61 |
| 8:50 AM                         | 1                       | 0    | 0     | 0 | 0                       | 1    | 0     | 0 | 0                         | 1    | 0     | 0 | 0                         | 1    | 0     | 0 | 0     | 4             | 59 |
| 8:55 AM                         | 0                       | 0    | 0     | 0 | 0                       | 0    | 1     | 0 | 0                         | 0    | 1     | 0 | 0                         | 0    | 0     | 0 | 0     | 2             | 55 |
| 9:00 AM                         | 0                       | 0    | 0     | 0 | 0                       | 0    | 2     | 0 | 0                         | 0    | 0     | 1 | 0                         | 0    | 0     | 0 | 0     | 3             | 56 |
| 9:05 AM                         | 2                       | 0    | 0     | 0 | 0                       | 0    | 0     | 0 | 0                         | 0    | 0     | 0 | 0                         | 1    | 0     | 0 | 0     | 3             | 53 |

**Attachment B**

| 5-Min Count Period Beginning At | Gravier St (Northbound) |      |       |   | Gravier St (Southbound) |      |       |   | Bienville Ave (Eastbound) |      |       |   | Bienville Ave (Westbound) |      |       |   | Total | Hourly Totals |
|---------------------------------|-------------------------|------|-------|---|-------------------------|------|-------|---|---------------------------|------|-------|---|---------------------------|------|-------|---|-------|---------------|
|                                 | Left                    | Thru | Right | U | Left                    | Thru | Right | U | Left                      | Thru | Right | U | Left                      | Thru | Right | U |       |               |
| 9:10 AM                         | 0                       | 0    | 1     | 0 | 0                       | 0    | 0     | 0 | 0                         | 0    | 0     | 0 | 0                         | 0    | 0     | 0 | 1     | 49            |
| 9:15 AM                         | 0                       | 0    | 1     | 0 | 0                       | 0    | 0     | 0 | 1                         | 0    | 0     | 0 | 0                         | 0    | 0     | 0 | 2     | 39            |
| 9:20 AM                         | 1                       | 0    | 0     | 0 | 0                       | 0    | 0     | 0 | 0                         | 0    | 0     | 0 | 0                         | 1    | 0     | 0 | 2     | 37            |
| 9:25 AM                         | 0                       | 0    | 0     | 0 | 0                       | 0    | 0     | 0 | 0                         | 0    | 0     | 0 | 0                         | 0    | 0     | 0 | 0     | 34            |
| 9:30 AM                         | 1                       | 0    | 0     | 0 | 0                       | 0    | 0     | 0 | 0                         | 0    | 1     | 0 | 0                         | 2    | 0     | 0 | 4     | 32            |
| 9:35 AM                         | 0                       | 0    | 0     | 0 | 0                       | 0    | 0     | 0 | 0                         | 0    | 0     | 0 | 0                         | 0    | 0     | 0 | 0     | 28            |
| 9:40 AM                         | 1                       | 0    | 0     | 0 | 0                       | 0    | 0     | 0 | 0                         | 0    | 0     | 0 | 0                         | 0    | 0     | 0 | 1     | 26            |
| 9:45 AM                         | 0                       | 0    | 0     | 0 | 0                       | 0    | 1     | 0 | 0                         | 1    | 0     | 0 | 1                         | 1    | 0     | 0 | 4     | 26            |
| 9:50 AM                         | 0                       | 0    | 0     | 0 | 0                       | 0    | 0     | 0 | 0                         | 0    | 0     | 0 | 0                         | 1    | 0     | 0 | 1     | 23            |
| 9:55 AM                         | 0                       | 0    | 0     | 0 | 0                       | 0    | 0     | 0 | 0                         | 0    | 0     | 0 | 0                         | 1    | 0     | 0 | 1     | 22            |
| 10:00 AM                        | 1                       | 0    | 0     | 0 | 0                       | 0    | 0     | 0 | 0                         | 0    | 1     | 0 | 0                         | 1    | 0     | 0 | 3     | 22            |
| 10:05 AM                        | 0                       | 0    | 0     | 0 | 0                       | 0    | 0     | 0 | 0                         | 0    | 0     | 0 | 0                         | 0    | 0     | 0 | 0     | 19            |
| 10:10 AM                        | 0                       | 0    | 0     | 0 | 0                       | 0    | 0     | 0 | 1                         | 0    | 0     | 0 | 0                         | 0    | 0     | 0 | 1     | 19            |
| 10:15 AM                        | 1                       | 0    | 0     | 0 | 0                       | 0    | 0     | 0 | 0                         | 1    | 0     | 0 | 0                         | 0    | 0     | 0 | 2     | 19            |
| 10:20 AM                        | 0                       | 0    | 0     | 0 | 0                       | 0    | 1     | 0 | 0                         | 0    | 2     | 0 | 0                         | 1    | 0     | 0 | 4     | 21            |
| 10:25 AM                        | 0                       | 0    | 0     | 0 | 0                       | 0    | 3     | 0 | 0                         | 0    | 2     | 0 | 0                         | 2    | 0     | 0 | 7     | 28            |
| 10:30 AM                        | 1                       | 0    | 0     | 0 | 0                       | 0    | 0     | 0 | 0                         | 1    | 0     | 0 | 0                         | 1    | 0     | 0 | 3     | 27            |
| 10:35 AM                        | 2                       | 0    | 0     | 0 | 0                       | 0    | 1     | 0 | 0                         | 0    | 0     | 0 | 0                         | 1    | 0     | 0 | 4     | 31            |
| 10:40 AM                        | 0                       | 0    | 0     | 0 | 0                       | 0    | 0     | 0 | 0                         | 0    | 2     | 0 | 0                         | 0    | 0     | 0 | 2     | 32            |
| 10:45 AM                        | 2                       | 0    | 0     | 0 | 0                       | 0    | 0     | 0 | 0                         | 0    | 0     | 0 | 0                         | 3    | 0     | 0 | 5     | 33            |
| 10:50 AM                        | 1                       | 0    | 0     | 0 | 0                       | 0    | 0     | 0 | 0                         | 1    | 0     | 0 | 0                         | 0    | 0     | 0 | 2     | 34            |
| 10:55 AM                        | 0                       | 0    | 0     | 0 | 0                       | 0    | 0     | 0 | 0                         | 1    | 1     | 0 | 0                         | 1    | 0     | 0 | 3     | 36            |
| 11:00 AM                        | 1                       | 0    | 0     | 0 | 0                       | 0    | 0     | 0 | 0                         | 1    | 1     | 0 | 0                         | 1    | 0     | 0 | 4     | 37            |
| 11:05 AM                        | 0                       | 0    | 0     | 0 | 0                       | 0    | 0     | 0 | 1                         | 0    | 1     | 0 | 0                         | 1    | 0     | 0 | 3     | 40            |
| 11:10 AM                        | 0                       | 0    | 0     | 0 | 0                       | 0    | 0     | 0 | 0                         | 0    | 1     | 0 | 0                         | 0    | 0     | 0 | 1     | 40            |
| 11:15 AM                        | 0                       | 0    | 0     | 0 | 0                       | 0    | 0     | 0 | 0                         | 2    | 1     | 0 | 0                         | 0    | 0     | 0 | 3     | 41            |
| 11:20 AM                        | 0                       | 0    | 0     | 0 | 0                       | 0    | 3     | 0 | 1                         | 1    | 0     | 0 | 0                         | 2    | 0     | 0 | 7     | 44            |
| 11:25 AM                        | 0                       | 0    | 0     | 0 | 0                       | 0    | 0     | 0 | 0                         | 2    | 0     | 0 | 0                         | 1    | 0     | 0 | 3     | 40            |
| 11:30 AM                        | 0                       | 0    | 0     | 0 | 0                       | 0    | 0     | 0 | 0                         | 0    | 0     | 0 | 0                         | 0    | 0     | 0 | 0     | 37            |
| 11:35 AM                        | 0                       | 0    | 0     | 0 | 0                       | 0    | 0     | 0 | 0                         | 0    | 0     | 0 | 0                         | 0    | 0     | 0 | 0     | 33            |
| 11:40 AM                        | 0                       | 0    | 0     | 0 | 0                       | 0    | 0     | 0 | 0                         | 0    | 2     | 0 | 0                         | 1    | 0     | 0 | 3     | 34            |
| 11:45 AM                        | 0                       | 0    | 0     | 0 | 0                       | 0    | 0     | 0 | 0                         | 0    | 0     | 0 | 0                         | 1    | 0     | 0 | 1     | 30            |
| 11:50 AM                        | 0                       | 0    | 0     | 0 | 0                       | 0    | 1     | 0 | 0                         | 2    | 2     | 0 | 0                         | 1    | 0     | 0 | 6     | 34            |
| 11:55 AM                        | 1                       | 0    | 0     | 0 | 0                       | 0    | 0     | 0 | 0                         | 0    | 0     | 0 | 0                         | 0    | 0     | 0 | 1     | 32            |
| 12:00 PM                        | 0                       | 0    | 0     | 0 | 0                       | 0    | 0     | 0 | 2                         | 0    | 1     | 0 | 0                         | 0    | 0     | 0 | 3     | 31            |
| 12:05 PM                        | 2                       | 1    | 0     | 0 | 0                       | 0    | 1     | 0 | 0                         | 1    | 0     | 0 | 0                         | 1    | 0     | 0 | 6     | 34            |
| 12:10 PM                        | 2                       | 0    | 0     | 0 | 0                       | 0    | 0     | 0 | 0                         | 0    | 0     | 0 | 0                         | 1    | 0     | 0 | 3     | 36            |
| 12:15 PM                        | 0                       | 0    | 0     | 0 | 0                       | 0    | 0     | 0 | 0                         | 0    | 0     | 0 | 0                         | 0    | 0     | 0 | 0     | 33            |
| 12:20 PM                        | 1                       | 0    | 1     | 0 | 0                       | 0    | 0     | 0 | 0                         | 0    | 0     | 0 | 0                         | 1    | 0     | 0 | 3     | 29            |
| 12:25 PM                        | 0                       | 0    | 0     | 0 | 0                       | 0    | 0     | 0 | 0                         | 0    | 0     | 0 | 0                         | 0    | 0     | 0 | 0     | 26            |
| 12:30 PM                        | 1                       | 0    | 0     | 0 | 0                       | 0    | 0     | 0 | 0                         | 0    | 0     | 0 | 0                         | 0    | 0     | 0 | 1     | 27            |
| 12:35 PM                        | 1                       | 0    | 0     | 0 | 0                       | 0    | 0     | 0 | 1                         | 0    | 0     | 0 | 0                         | 1    | 0     | 0 | 3     | 30            |
| 12:40 PM                        | 1                       | 0    | 0     | 0 | 0                       | 0    | 1     | 0 | 0                         | 0    | 3     | 0 | 0                         | 0    | 0     | 0 | 5     | 32            |
| 12:45 PM                        | 1                       | 0    | 0     | 0 | 0                       | 0    | 0     | 0 | 0                         | 1    | 0     | 0 | 0                         | 1    | 0     | 0 | 3     | 34            |
| 12:50 PM                        | 0                       | 0    | 0     | 0 | 0                       | 0    | 0     | 0 | 0                         | 1    | 3     | 0 | 0                         | 0    | 0     | 0 | 4     | 32            |
| 12:55 PM                        | 1                       | 0    | 0     | 0 | 0                       | 0    | 0     | 0 | 0                         | 1    | 0     | 0 | 0                         | 0    | 0     | 0 | 2     | 33            |
| 1:00 PM                         | 1                       | 0    | 0     | 0 | 0                       | 0    | 0     | 0 | 0                         | 1    | 2     | 0 | 0                         | 0    | 0     | 0 | 4     | 34            |
| 1:05 PM                         | 2                       | 0    | 0     | 0 | 0                       | 0    | 1     | 0 | 0                         | 1    | 0     | 0 | 0                         | 2    | 0     | 0 | 6     | 34            |
| 1:10 PM                         | 0                       | 0    | 0     | 0 | 0                       | 0    | 0     | 0 | 0                         | 0    | 1     | 0 | 0                         | 1    | 0     | 0 | 2     | 33            |
| 1:15 PM                         | 0                       | 0    | 0     | 0 | 0                       | 0    | 0     | 0 | 0                         | 0    | 1     | 0 | 0                         | 1    | 0     | 0 | 2     | 35            |
| 1:20 PM                         | 1                       | 0    | 0     | 0 | 0                       | 0    | 0     | 0 | 0                         | 1    | 3     | 0 | 0                         | 1    | 0     | 0 | 6     | 38            |
| 1:25 PM                         | 1                       | 0    | 0     | 0 | 0                       | 0    | 1     | 0 | 0                         | 0    | 2     | 0 | 0                         | 0    | 0     | 0 | 4     | 42            |
| 1:30 PM                         | 1                       | 0    | 0     | 0 | 0                       | 0    | 0     | 0 | 0                         | 1    | 0     | 0 | 0                         | 1    | 0     | 0 | 3     | 44            |
| 1:35 PM                         | 0                       | 0    | 0     | 0 | 0                       | 0    | 1     | 0 | 0                         | 3    | 0     | 0 | 0                         | 1    | 0     | 0 | 5     | 46            |
| 1:40 PM                         | 0                       | 0    | 0     | 0 | 0                       | 0    | 0     | 0 | 0                         | 0    | 1     | 0 | 0                         | 0    | 0     | 0 | 1     | 42            |
| 1:45 PM                         | 1                       | 0    | 0     | 0 | 0                       | 0    | 0     | 0 | 0                         | 0    | 0     | 0 | 0                         | 0    | 0     | 0 | 1     | 40            |
| 1:50 PM                         | 1                       | 0    | 0     | 0 | 0                       | 0    | 0     | 0 | 0                         | 1    | 1     | 0 | 0                         | 0    | 0     | 0 | 3     | 39            |
| 1:55 PM                         | 3                       | 0    | 0     | 0 | 0                       | 0    | 1     | 0 | 0                         | 2    | 0     | 0 | 0                         | 0    | 0     | 0 | 6     | 43            |
| 2:00 PM                         | 0                       | 0    | 0     | 0 | 0                       | 0    | 0     | 0 | 0                         | 0    | 0     | 0 | 0                         | 1    | 0     | 0 | 1     | 40            |
| 2:05 PM                         | 0                       | 0    | 0     | 0 | 0                       | 0    | 0     | 0 | 0                         | 0    | 0     | 0 | 0                         | 1    | 0     | 0 | 1     | 35            |
| 2:10 PM                         | 0                       | 0    | 0     | 0 | 0                       | 0    | 0     | 0 | 0                         | 1    | 0     | 0 | 0                         | 0    | 0     | 0 | 1     | 34            |
| 2:15 PM                         | 0                       | 0    | 0     | 0 | 0                       | 0    | 0     | 0 | 0                         | 0    | 1     | 0 | 0                         | 0    | 0     | 0 | 1     | 33            |
| 2:20 PM                         | 1                       | 1    | 0     | 0 | 1                       | 0    | 0     | 0 | 0                         | 0    | 0     | 0 | 0                         | 0    | 0     | 0 | 3     | 30            |
| 2:25 PM                         | 0                       | 0    | 0     | 0 | 0                       | 0    | 1     | 0 | 0                         | 0    | 0     | 0 | 1                         | 0    | 0     | 0 | 2     | 28            |
| 2:30 PM                         | 0                       | 0    | 0     | 0 | 0                       | 0    | 0     | 0 | 1                         | 1    | 0     | 0 | 0                         | 3    | 0     | 0 | 5     | 30            |
| 2:35 PM                         | 1                       | 1    | 1     | 0 | 0                       | 0    | 0     | 0 | 0                         | 0    | 0     | 0 | 0                         | 0    | 0     | 0 | 3     | 28            |
| 2:40 PM                         | 1                       | 0    | 0     | 0 | 0                       | 0    | 0     | 0 | 1                         | 1    | 0     | 0 | 0                         | 1    | 0     | 0 | 4     | 31            |
| 2:45 PM                         | 2                       | 0    | 0     | 0 | 0                       | 0    | 0     | 0 | 0                         | 0    | 0     | 0 | 0                         | 0    | 0     | 0 | 2     | 32            |
| 2:50 PM                         | 1                       | 0    | 0     | 0 | 0                       | 0    | 1     | 0 | 0                         | 1    | 0     | 0 | 0                         | 0    | 0     | 0 | 3     | 32            |
| 2:55 PM                         | 0                       | 0    | 0     | 0 | 0                       | 0    | 1     | 0 | 0                         | 1    | 0     | 0 | 0                         | 1    | 0     | 0 | 3     | 29            |
| 3:00 PM                         | 1                       | 0    | 0     | 0 | 0                       | 0    | 0     | 0 | 0                         | 1    | 1     | 0 | 0                         | 0    | 0     | 0 | 3     | 31            |
| 3:05 PM                         | 0                       | 0    | 0     | 0 | 0                       | 0    | 0     | 0 | 0                         | 1    | 0     | 0 | 0                         | 1    | 0     | 0 | 2     | 32            |
| 3:10 PM                         | 1                       | 0    | 0     | 0 | 0                       | 0    | 0     | 0 | 1                         | 2    | 0     | 0 | 0                         | 1    | 0     | 0 | 5     | 36            |
| 3:15 PM                         | 0                       | 0    | 0     | 0 | 0                       | 0    | 0     | 0 | 0                         | 1    | 1     | 0 | 0                         | 0    | 0     | 0 | 2     | 37            |
| 3:20 PM                         | 1                       | 0    | 0     | 0 | 0                       | 0    | 0     | 0 | 0                         | 2    | 0     | 0 | 0                         | 0    | 0     | 0 | 3     | 37            |
| 3:25 PM                         | 0                       | 0    | 0     | 0 | 0                       | 0    | 0     | 0 | 0                         | 1    | 0     | 0 | 0                         | 0    | 0     | 0 | 1     | 36            |
| 3:30 PM                         | 0                       | 0    | 0     | 0 | 0                       | 0    | 1     | 0 | 0                         | 0    | 1     | 0 | 0                         | 0    | 0     | 0 | 2     | 33            |
| 3:35 PM                         | 0                       | 0    | 0     | 0 | 0                       | 0    | 0     | 0 | 0                         | 0    | 1     | 0 | 0                         | 0    | 0     | 0 | 1     | 31            |
| 3:40 PM                         | 1                       | 0    | 0     | 0 | 0                       | 0    | 0     | 0 | 0                         | 2    | 0     | 0 | 0                         | 2    | 0     | 0 | 5     | 32            |
| 3:45 PM                         | 1                       | 1    | 0     | 0 | 0                       | 0    | 0     | 0 | 0                         | 1    | 1     | 0 | 0                         | 0    | 0     | 0 | 4     | 34            |
| 3:50 PM                         | 0                       | 0    | 0     | 0 | 0                       | 0    | 0     | 0 | 2                         | 0    | 0     | 0 | 1                         | 2    | 0     | 0 | 5     | 36            |
| 3:55 PM                         | 1                       | 0    | 0     | 0 | 0                       | 0    | 1     | 0 | 0                         | 1    | 2     | 0 | 0                         | 1    | 0     | 0 | 6     | 39            |
| 4:00 PM                         | 0                       | 1    | 0     | 0 | 0                       | 0    | 0     | 0 | 0                         | 1    | 0     | 0 | 0                         | 0    | 0     | 0 | 2     | 38            |
| 4:05 PM                         | 1                       | 0    | 0     | 0 | 0                       | 0    | 1     | 0 | 1                         | 0    | 0     | 0 | 0                         | 1    | 0     | 0 | 4     | 40            |
| 4:10 PM                         | 0                       | 0    | 0     | 0 | 0                       | 0    | 1     | 0 | 0                         | 3    | 1     | 0 | 0                         | 2    | 0     | 0 | 7     | 42            |
| 4:15 PM                         | 0                       | 1    | 0     | 0 | 0                       | 0    | 1     | 0 | 0                         | 1    | 1     | 0 | 0                         | 0    | 0     | 0 | 4     | 44            |
| 4:20 PM                         | 0                       | 0    | 0     | 0 | 0                       | 0    | 0     | 0 | 1                         | 0    | 0     | 0 | 0                         | 2    | 1     | 0 | 4     | 45            |
| 4:25 PM                         | 1                       | 0    | 0     | 0 | 0                       | 0    | 0     | 0 | 1                         | 1    | 2     | 0 | 0                         | 0    | 0     | 0 | 5     | 49            |
| 4:30 PM                         | 2                       | 0    | 1     | 0 | 0                       | 0    | 0     | 0 | 1                         | 1    | 0     | 0 | 0                         | 2    | 0     | 0 | 7     | 54            |

**Attachment B**

| 5-Min Count Period Beginning At | Gravier St (Northbound) |      |       |   | Gravier St (Southbound) |      |       |   | Bienville Ave (Eastbound) |      |       |   | Bienville Ave (Westbound) |      |       |   | Total | Hourly Totals |
|---------------------------------|-------------------------|------|-------|---|-------------------------|------|-------|---|---------------------------|------|-------|---|---------------------------|------|-------|---|-------|---------------|
|                                 | Left                    | Thru | Right | U | Left                    | Thru | Right | U | Left                      | Thru | Right | U | Left                      | Thru | Right | U |       |               |
| 4:35 PM                         | 0                       | 0    | 0     | 0 | 0                       | 0    | 0     | 0 | 0                         | 2    | 2     | 0 | 0                         | 0    | 0     | 0 | 4     | 57            |
| 4:40 PM                         | 0                       | 0    | 1     | 0 | 0                       | 0    | 0     | 0 | 0                         | 0    | 3     | 2 | 0                         | 0    | 0     | 0 | 6     | 58            |
| 4:45 PM                         | 2                       | 0    | 0     | 0 | 0                       | 0    | 0     | 0 | 0                         | 2    | 1     | 0 | 0                         | 0    | 0     | 0 | 5     | 59            |
| 4:50 PM                         | 0                       | 0    | 0     | 0 | 0                       | 0    | 0     | 0 | 1                         | 1    | 1     | 0 | 0                         | 2    | 0     | 0 | 5     | 59            |
| 4:55 PM                         | 1                       | 0    | 0     | 0 | 0                       | 0    | 0     | 0 | 0                         | 1    | 1     | 0 | 0                         | 1    | 0     | 0 | 4     | 57            |
| 5:00 PM                         | 2                       | 0    | 0     | 0 | 0                       | 0    | 0     | 0 | 0                         | 2    | 0     | 0 | 0                         | 0    | 0     | 0 | 4     | 59            |
| 5:05 PM                         | 2                       | 0    | 1     | 0 | 0                       | 0    | 0     | 0 | 1                         | 3    | 1     | 0 | 0                         | 2    | 0     | 0 | 10    | 65            |
| 5:10 PM                         | 0                       | 0    | 0     | 0 | 0                       | 0    | 1     | 0 | 0                         | 1    | 0     | 0 | 0                         | 1    | 0     | 0 | 3     | 61            |
| 5:15 PM                         | 0                       | 0    | 0     | 0 | 0                       | 0    | 1     | 0 | 1                         | 1    | 0     | 0 | 0                         | 0    | 0     | 0 | 3     | 60            |
| 5:20 PM                         | 0                       | 0    | 0     | 0 | 0                       | 0    | 0     | 0 | 1                         | 1    | 3     | 0 | 0                         | 0    | 0     | 0 | 5     | 61            |
| 5:25 PM                         | 1                       | 0    | 0     | 0 | 0                       | 0    | 1     | 0 | 0                         | 0    | 0     | 0 | 0                         | 1    | 0     | 0 | 3     | 59            |
| 5:30 PM                         | 1                       | 0    | 0     | 0 | 1                       | 0    | 2     | 0 | 1                         | 0    | 1     | 0 | 0                         | 2    | 0     | 0 | 8     | 60            |
| 5:35 PM                         | 1                       | 0    | 0     | 0 | 0                       | 0    | 0     | 0 | 1                         | 2    | 1     | 0 | 0                         | 1    | 0     | 0 | 6     | 62            |
| 5:40 PM                         | 0                       | 1    | 0     | 0 | 0                       | 0    | 0     | 0 | 1                         | 1    | 0     | 0 | 0                         | 1    | 0     | 0 | 4     | 60            |
| 5:45 PM                         | 0                       | 0    | 1     | 0 | 0                       | 0    | 0     | 0 | 0                         | 1    | 0     | 0 | 0                         | 2    | 0     | 0 | 4     | 59            |
| 5:50 PM                         | 0                       | 0    | 0     | 0 | 0                       | 0    | 1     | 0 | 0                         | 0    | 0     | 0 | 0                         | 2    | 0     | 0 | 3     | 57            |
| 5:55 PM                         | 0                       | 0    | 0     | 0 | 0                       | 0    | 0     | 0 | 1                         | 2    | 2     | 0 | 0                         | 1    | 0     | 0 | 6     | 59            |
| 6:00 PM                         | 2                       | 0    | 0     | 0 | 0                       | 0    | 0     | 0 | 0                         | 0    | 1     | 0 | 0                         | 0    | 0     | 0 | 3     | 58            |
| 6:05 PM                         | 0                       | 0    | 0     | 0 | 0                       | 0    | 1     | 0 | 2                         | 2    | 0     | 0 | 0                         | 0    | 0     | 0 | 5     | 53            |
| 6:10 PM                         | 1                       | 0    | 0     | 0 | 0                       | 0    | 0     | 0 | 0                         | 1    | 1     | 0 | 0                         | 2    | 0     | 0 | 5     | 55            |
| 6:15 PM                         | 0                       | 0    | 0     | 0 | 0                       | 0    | 0     | 0 | 1                         | 0    | 0     | 0 | 0                         | 2    | 0     | 0 | 3     | 55            |
| 6:20 PM                         | 0                       | 1    | 0     | 0 | 0                       | 0    | 0     | 0 | 1                         | 3    | 1     | 0 | 1                         | 2    | 0     | 0 | 9     | 59            |
| 6:25 PM                         | 1                       | 0    | 0     | 0 | 0                       | 0    | 0     | 0 | 1                         | 0    | 2     | 0 | 0                         | 0    | 0     | 0 | 4     | 60            |
| 6:30 PM                         | 0                       | 0    | 0     | 0 | 0                       | 0    | 1     | 0 | 0                         | 0    | 0     | 0 | 0                         | 2    | 0     | 0 | 3     | 55            |
| 6:35 PM                         | 1                       | 0    | 0     | 0 | 0                       | 0    | 0     | 0 | 0                         | 4    | 0     | 0 | 0                         | 1    | 0     | 0 | 6     | 55            |
| 6:40 PM                         | 0                       | 0    | 1     | 0 | 0                       | 0    | 0     | 0 | 0                         | 1    | 1     | 0 | 0                         | 1    | 0     | 0 | 4     | 55            |
| 6:45 PM                         | 0                       | 0    | 0     | 0 | 0                       | 0    | 1     | 0 | 0                         | 1    | 0     | 0 | 0                         | 1    | 0     | 0 | 3     | 54            |
| 6:50 PM                         | 0                       | 0    | 0     | 0 | 0                       | 0    | 0     | 0 | 0                         | 0    | 1     | 0 | 0                         | 1    | 0     | 0 | 2     | 53            |
| 6:55 PM                         | 1                       | 0    | 0     | 0 | 0                       | 0    | 0     | 0 | 0                         | 2    | 1     | 0 | 0                         | 1    | 0     | 0 | 5     | 52            |
| 7:00 PM                         | 1                       | 0    | 1     | 0 | 0                       | 0    | 0     | 0 | 0                         | 3    | 2     | 0 | 0                         | 0    | 0     | 0 | 7     | 56            |
| 7:05 PM                         | 2                       | 0    | 0     | 0 | 0                       | 0    | 1     | 0 | 1                         | 1    | 0     | 0 | 0                         | 2    | 1     | 0 | 8     | 59            |
| 7:10 PM                         | 1                       | 0    | 0     | 0 | 0                       | 0    | 2     | 0 | 0                         | 1    | 1     | 0 | 0                         | 0    | 0     | 0 | 5     | 59            |
| 7:15 PM                         | 2                       | 0    | 0     | 0 | 0                       | 0    | 0     | 0 | 1                         | 0    | 1     | 0 | 0                         | 1    | 0     | 0 | 5     | 61            |
| 7:20 PM                         | 0                       | 0    | 0     | 0 | 0                       | 0    | 0     | 0 | 0                         | 0    | 0     | 0 | 0                         | 0    | 0     | 0 | 0     | 52            |
| 7:25 PM                         | 1                       | 0    | 0     | 0 | 0                       | 0    | 0     | 0 | 0                         | 1    | 0     | 0 | 0                         | 1    | 0     | 0 | 3     | 51            |
| 7:30 PM                         | 2                       | 0    | 0     | 0 | 0                       | 0    | 1     | 0 | 0                         | 2    | 1     | 0 | 0                         | 0    | 0     | 0 | 6     | 54            |
| 7:35 PM                         | 1                       | 0    | 0     | 0 | 0                       | 0    | 0     | 0 | 0                         | 0    | 0     | 0 | 0                         | 0    | 0     | 0 | 1     | 49            |
| 7:40 PM                         | 0                       | 0    | 0     | 0 | 0                       | 0    | 0     | 0 | 0                         | 0    | 0     | 0 | 0                         | 1    | 0     | 0 | 1     | 46            |
| 7:45 PM                         | 1                       | 0    | 1     | 0 | 0                       | 0    | 0     | 0 | 0                         | 3    | 0     | 0 | 0                         | 0    | 0     | 0 | 5     | 48            |
| 7:50 PM                         | 1                       | 0    | 0     | 0 | 0                       | 0    | 0     | 0 | 1                         | 0    | 1     | 0 | 0                         | 1    | 0     | 0 | 4     | 50            |
| 7:55 PM                         | 1                       | 1    | 0     | 0 | 0                       | 0    | 0     | 0 | 0                         | 0    | 2     | 0 | 0                         | 0    | 0     | 0 | 4     | 49            |
| 8:00 PM                         | 1                       | 0    | 0     | 0 | 0                       | 0    | 0     | 0 | 1                         | 3    | 1     | 0 | 0                         | 1    | 0     | 0 | 7     | 49            |
| 8:05 PM                         | 0                       | 0    | 0     | 0 | 1                       | 1    | 0     | 0 | 1                         | 4    | 1     | 0 | 0                         | 1    | 1     | 0 | 10    | 51            |
| 8:10 PM                         | 0                       | 0    | 0     | 0 | 0                       | 0    | 0     | 0 | 1                         | 4    | 1     | 0 | 0                         | 1    | 0     | 0 | 7     | 53            |
| 8:15 PM                         | 0                       | 0    | 0     | 0 | 0                       | 0    | 0     | 0 | 0                         | 1    | 0     | 0 | 0                         | 1    | 0     | 0 | 2     | 50            |
| 8:20 PM                         | 0                       | 0    | 0     | 0 | 0                       | 0    | 0     | 0 | 0                         | 0    | 0     | 0 | 0                         | 0    | 0     | 0 | 0     | 50            |
| 8:25 PM                         | 0                       | 0    | 0     | 0 | 0                       | 0    | 1     | 0 | 0                         | 0    | 0     | 0 | 0                         | 0    | 0     | 0 | 1     | 48            |
| 8:30 PM                         | 1                       | 0    | 0     | 0 | 0                       | 0    | 0     | 0 | 0                         | 1    | 0     | 0 | 0                         | 0    | 0     | 0 | 2     | 44            |
| 8:35 PM                         | 1                       | 0    | 0     | 0 | 0                       | 0    | 0     | 0 | 1                         | 0    | 1     | 0 | 0                         | 0    | 0     | 0 | 3     | 46            |
| 8:40 PM                         | 0                       | 0    | 0     | 0 | 0                       | 0    | 1     | 0 | 2                         | 1    | 1     | 0 | 0                         | 0    | 0     | 0 | 5     | 50            |
| 8:45 PM                         | 1                       | 0    | 0     | 0 | 0                       | 0    | 1     | 0 | 0                         | 0    | 1     | 0 | 0                         | 2    | 0     | 0 | 5     | 50            |
| 8:50 PM                         | 0                       | 0    | 1     | 0 | 0                       | 0    | 0     | 0 | 1                         | 0    | 0     | 0 | 0                         | 1    | 0     | 0 | 3     | 49            |
| 8:55 PM                         | 0                       | 0    | 0     | 0 | 0                       | 0    | 0     | 0 | 1                         | 1    | 0     | 0 | 0                         | 0    | 0     | 0 | 2     | 47            |
| 9:00 PM                         | 2                       | 0    | 0     | 0 | 0                       | 0    | 0     | 0 | 0                         | 2    | 0     | 0 | 0                         | 0    | 0     | 0 | 4     | 44            |
| 9:05 PM                         | 0                       | 0    | 0     | 0 | 0                       | 0    | 0     | 0 | 1                         | 0    | 0     | 0 | 0                         | 3    | 0     | 0 | 4     | 38            |
| 9:10 PM                         | 0                       | 0    | 0     | 0 | 0                       | 0    | 0     | 0 | 0                         | 0    | 0     | 0 | 0                         | 0    | 0     | 0 | 0     | 31            |
| 9:15 PM                         | 0                       | 0    | 0     | 0 | 0                       | 0    | 0     | 0 | 0                         | 0    | 0     | 0 | 0                         | 0    | 0     | 0 | 0     | 29            |
| 9:20 PM                         | 1                       | 1    | 1     | 0 | 0                       | 0    | 0     | 0 | 0                         | 0    | 0     | 0 | 0                         | 0    | 0     | 0 | 3     | 32            |
| 9:25 PM                         | 0                       | 0    | 0     | 0 | 0                       | 0    | 0     | 0 | 0                         | 0    | 0     | 0 | 0                         | 0    | 0     | 0 | 0     | 31            |
| 9:30 PM                         | 0                       | 0    | 0     | 0 | 0                       | 0    | 0     | 0 | 0                         | 2    | 1     | 0 | 0                         | 0    | 0     | 0 | 3     | 32            |
| 9:35 PM                         | 1                       | 0    | 1     | 0 | 0                       | 0    | 1     | 0 | 1                         | 1    | 0     | 0 | 0                         | 3    | 0     | 0 | 8     | 37            |
| 9:40 PM                         | 1                       | 0    | 0     | 0 | 0                       | 0    | 0     | 0 | 0                         | 0    | 0     | 0 | 0                         | 0    | 0     | 0 | 1     | 33            |
| 9:45 PM                         | 0                       | 0    | 0     | 0 | 0                       | 0    | 0     | 0 | 0                         | 0    | 0     | 0 | 0                         | 1    | 0     | 0 | 1     | 29            |
| 9:50 PM                         | 0                       | 0    | 0     | 0 | 0                       | 0    | 0     | 0 | 0                         | 0    | 0     | 0 | 0                         | 1    | 0     | 0 | 1     | 27            |
| 9:55 PM                         | 0                       | 0    | 0     | 0 | 0                       | 0    | 0     | 0 | 0                         | 1    | 0     | 0 | 0                         | 1    | 0     | 0 | 2     | 27            |
| Peak 15-Min Flowrates           | Northbound              |      |       |   | Southbound              |      |       |   | Eastbound                 |      |       |   | Westbound                 |      |       |   | Total |               |
|                                 | Left                    | Thru | Right | U | Left                    | Thru | Right | U | Left                      | Thru | Right | U | Left                      | Thru | Right | U |       |               |
| All Vehicles                    | 24                      | 0    | 0     | 0 | 0                       | 0    | 8     | 0 | 4                         | 20   | 12    | 0 | 0                         | 24   | 0     | 0 | 92    |               |
| Heavy Trucks                    | 0                       | 0    | 0     |   | 0                       | 0    | 0     |   | 0                         | 0    | 4     |   | 0                         | 0    | 0     |   | 4     |               |
| Buses                           |                         |      |       |   |                         |      |       |   |                           |      |       |   |                           |      |       |   |       |               |
| Pedestrians                     |                         | 0    |       |   |                         | 0    |       |   |                           | 0    |       |   |                           | 0    |       |   | 0     |               |
| Bicycles                        | 0                       | 0    | 0     |   | 0                       | 0    | 0     |   | 0                         | 0    | 0     |   | 0                         | 0    | 0     |   | 0     |               |
| Scoters                         |                         |      |       |   |                         |      |       |   |                           |      |       |   |                           |      |       |   |       |               |
| <i>Comments:</i>                |                         |      |       |   |                         |      |       |   |                           |      |       |   |                           |      |       |   |       |               |

LOCATION: Yardley St -- S Harvest Ln  
 CITY/STATE: Orange, CA

QC JOB #: 16966430  
 DATE: Wed, Apr 9 2025

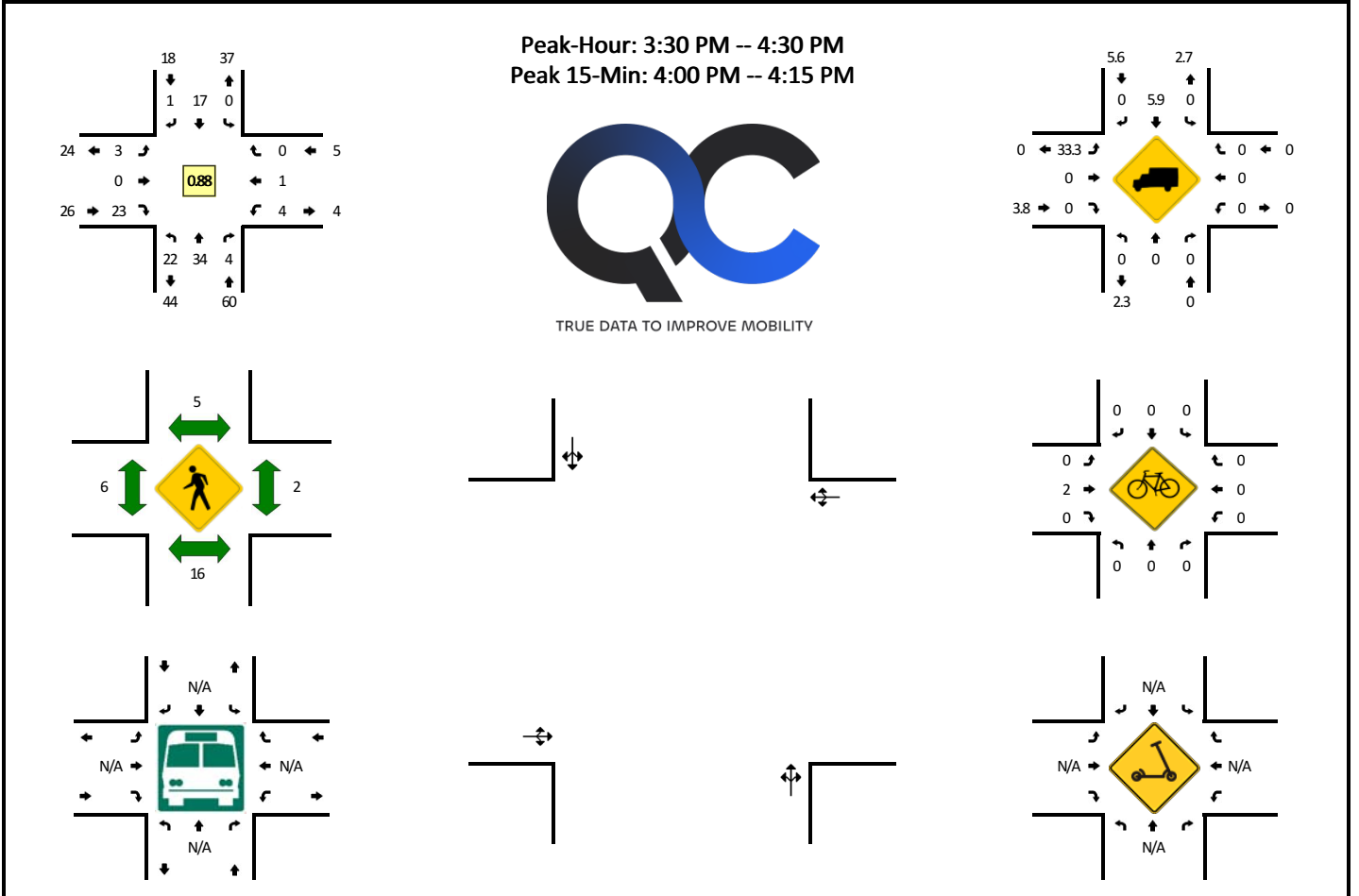

| 5-Min Count Period Beginning At | Yardley St (Northbound) |      |       |   | Yardley St (Southbound) |      |       |   | S Harvest Ln (Eastbound) |      |       |   | S Harvest Ln (Westbound) |      |       |   | Total | Hourly Totals |     |
|---------------------------------|-------------------------|------|-------|---|-------------------------|------|-------|---|--------------------------|------|-------|---|--------------------------|------|-------|---|-------|---------------|-----|
|                                 | Left                    | Thru | Right | U | Left                    | Thru | Right | U | Left                     | Thru | Right | U | Left                     | Thru | Right | U |       |               |     |
| 6:00 AM                         | 2                       | 0    | 0     | 0 | 0                       | 1    | 0     | 0 | 0                        | 0    | 0     | 0 | 0                        | 0    | 0     | 0 | 3     |               |     |
| 6:05 AM                         | 1                       | 0    | 0     | 0 | 0                       | 3    | 0     | 0 | 0                        | 0    | 0     | 0 | 0                        | 0    | 1     | 0 | 0     | 5             |     |
| 6:10 AM                         | 1                       | 0    | 0     | 0 | 0                       | 1    | 0     | 0 | 0                        | 1    | 0     | 3 | 0                        | 0    | 0     | 0 | 0     | 6             |     |
| 6:15 AM                         | 0                       | 1    | 0     | 0 | 0                       | 1    | 0     | 0 | 0                        | 0    | 0     | 2 | 0                        | 0    | 0     | 0 | 0     | 4             |     |
| 6:20 AM                         | 0                       | 3    | 0     | 0 | 0                       | 1    | 0     | 0 | 0                        | 0    | 0     | 0 | 0                        | 0    | 0     | 0 | 0     | 4             |     |
| 6:25 AM                         | 0                       | 0    | 0     | 0 | 0                       | 2    | 0     | 0 | 0                        | 0    | 0     | 1 | 0                        | 0    | 0     | 0 | 0     | 3             |     |
| 6:30 AM                         | 0                       | 1    | 0     | 0 | 0                       | 5    | 0     | 0 | 0                        | 0    | 0     | 2 | 0                        | 0    | 0     | 0 | 0     | 8             |     |
| 6:35 AM                         | 0                       | 0    | 0     | 0 | 0                       | 1    | 0     | 0 | 0                        | 0    | 0     | 1 | 0                        | 0    | 0     | 0 | 0     | 2             |     |
| 6:40 AM                         | 0                       | 1    | 0     | 0 | 0                       | 0    | 0     | 0 | 0                        | 0    | 0     | 3 | 0                        | 1    | 0     | 0 | 0     | 5             |     |
| 6:45 AM                         | 0                       | 1    | 0     | 0 | 0                       | 2    | 0     | 0 | 0                        | 0    | 0     | 1 | 0                        | 1    | 0     | 0 | 0     | 5             |     |
| 6:50 AM                         | 1                       | 0    | 0     | 0 | 0                       | 7    | 0     | 0 | 0                        | 0    | 0     | 1 | 0                        | 0    | 0     | 0 | 0     | 9             |     |
| 6:55 AM                         | 0                       | 2    | 0     | 0 | 0                       | 1    | 0     | 0 | 0                        | 0    | 0     | 0 | 0                        | 0    | 0     | 0 | 0     | 3             | 57  |
| 7:00 AM                         | 0                       | 3    | 0     | 0 | 0                       | 1    | 0     | 0 | 0                        | 0    | 0     | 4 | 0                        | 1    | 0     | 0 | 0     | 9             | 63  |
| 7:05 AM                         | 0                       | 2    | 0     | 0 | 0                       | 4    | 0     | 0 | 0                        | 0    | 0     | 3 | 0                        | 0    | 0     | 0 | 0     | 9             | 67  |
| 7:10 AM                         | 0                       | 0    | 0     | 0 | 0                       | 4    | 0     | 0 | 0                        | 0    | 0     | 0 | 0                        | 0    | 0     | 0 | 0     | 4             | 65  |
| 7:15 AM                         | 0                       | 1    | 0     | 0 | 0                       | 4    | 1     | 0 | 0                        | 1    | 0     | 1 | 0                        | 0    | 0     | 0 | 0     | 8             | 69  |
| 7:20 AM                         | 0                       | 0    | 0     | 0 | 0                       | 4    | 0     | 0 | 0                        | 0    | 0     | 2 | 0                        | 0    | 0     | 0 | 0     | 6             | 71  |
| 7:25 AM                         | 1                       | 1    | 0     | 0 | 0                       | 3    | 0     | 0 | 0                        | 0    | 0     | 2 | 0                        | 0    | 0     | 0 | 0     | 7             | 75  |
| 7:30 AM                         | 0                       | 1    | 0     | 0 | 0                       | 4    | 1     | 0 | 0                        | 0    | 0     | 0 | 0                        | 0    | 0     | 0 | 0     | 6             | 73  |
| 7:35 AM                         | 1                       | 2    | 0     | 0 | 0                       | 3    | 0     | 0 | 0                        | 0    | 0     | 3 | 0                        | 0    | 0     | 0 | 0     | 9             | 80  |
| 7:40 AM                         | 0                       | 1    | 0     | 0 | 0                       | 4    | 0     | 0 | 0                        | 0    | 0     | 1 | 0                        | 0    | 0     | 0 | 0     | 6             | 81  |
| 7:45 AM                         | 1                       | 3    | 0     | 0 | 0                       | 2    | 0     | 0 | 0                        | 0    | 0     | 1 | 0                        | 0    | 0     | 0 | 0     | 7             | 83  |
| 7:50 AM                         | 0                       | 1    | 0     | 0 | 0                       | 4    | 0     | 0 | 0                        | 0    | 0     | 2 | 0                        | 2    | 0     | 0 | 0     | 9             | 83  |
| 7:55 AM                         | 0                       | 3    | 0     | 0 | 0                       | 4    | 0     | 0 | 0                        | 0    | 0     | 1 | 0                        | 0    | 0     | 0 | 0     | 8             | 88  |
| 8:00 AM                         | 0                       | 3    | 0     | 0 | 0                       | 3    | 0     | 0 | 0                        | 1    | 0     | 4 | 0                        | 1    | 0     | 0 | 0     | 12            | 91  |
| 8:05 AM                         | 1                       | 3    | 0     | 0 | 0                       | 6    | 0     | 0 | 0                        | 0    | 0     | 2 | 0                        | 0    | 0     | 0 | 0     | 12            | 94  |
| 8:10 AM                         | 1                       | 0    | 0     | 0 | 0                       | 2    | 0     | 0 | 0                        | 0    | 0     | 2 | 0                        | 0    | 0     | 0 | 0     | 5             | 95  |
| 8:15 AM                         | 1                       | 3    | 0     | 0 | 0                       | 1    | 0     | 0 | 0                        | 0    | 0     | 0 | 0                        | 0    | 0     | 0 | 0     | 5             | 92  |
| 8:20 AM                         | 2                       | 2    | 0     | 0 | 0                       | 3    | 1     | 0 | 0                        | 0    | 0     | 4 | 0                        | 0    | 0     | 0 | 0     | 12            | 98  |
| 8:25 AM                         | 3                       | 4    | 0     | 0 | 0                       | 5    | 0     | 0 | 0                        | 0    | 0     | 0 | 0                        | 0    | 0     | 0 | 0     | 12            | 103 |
| 8:30 AM                         | 0                       | 2    | 0     | 0 | 0                       | 4    | 0     | 0 | 0                        | 1    | 0     | 1 | 0                        | 0    | 0     | 0 | 0     | 8             | 105 |
| 8:35 AM                         | 1                       | 1    | 0     | 0 | 0                       | 1    | 0     | 0 | 0                        | 0    | 0     | 1 | 0                        | 0    | 0     | 0 | 0     | 4             | 100 |
| 8:40 AM                         | 2                       | 1    | 0     | 0 | 0                       | 0    | 0     | 0 | 0                        | 0    | 0     | 2 | 0                        | 0    | 0     | 0 | 0     | 5             | 99  |
| 8:45 AM                         | 0                       | 4    | 0     | 0 | 0                       | 1    | 1     | 0 | 0                        | 0    | 0     | 2 | 0                        | 0    | 0     | 0 | 0     | 8             | 100 |
| 8:50 AM                         | 0                       | 2    | 0     | 0 | 0                       | 2    | 0     | 0 | 0                        | 0    | 0     | 2 | 0                        | 1    | 0     | 0 | 0     | 7             | 98  |
| 8:55 AM                         | 0                       | 2    | 0     | 0 | 0                       | 2    | 0     | 0 | 0                        | 0    | 0     | 1 | 0                        | 0    | 0     | 0 | 0     | 5             | 95  |
| 9:00 AM                         | 1                       | 2    | 1     | 0 | 0                       | 0    | 0     | 0 | 0                        | 0    | 0     | 2 | 0                        | 1    | 0     | 0 | 0     | 7             | 90  |
| 9:05 AM                         | 1                       | 2    | 1     | 0 | 0                       | 0    | 0     | 0 | 0                        | 0    | 0     | 2 | 0                        | 0    | 0     | 0 | 0     | 6             | 84  |

Attachment B

| 5-Min Count Period Beginning At | Yardley St (Northbound) |      |       |   | Yardley St (Southbound) |      |       |   | S Harvest Ln (Eastbound) |      |       |   | S Harvest Ln (Westbound) |      |       |   | Total | Hourly Totals |
|---------------------------------|-------------------------|------|-------|---|-------------------------|------|-------|---|--------------------------|------|-------|---|--------------------------|------|-------|---|-------|---------------|
|                                 | Left                    | Thru | Right | U | Left                    | Thru | Right | U | Left                     | Thru | Right | U | Left                     | Thru | Right | U |       |               |
| 9:10 AM                         | 1                       | 0    | 0     | 0 | 0                       | 4    | 0     | 0 | 0                        | 0    | 1     | 0 | 0                        | 0    | 1     | 0 | 7     | 86            |
| 9:15 AM                         | 1                       | 0    | 0     | 0 | 0                       | 2    | 0     | 0 | 0                        | 0    | 0     | 2 | 0                        | 0    | 0     | 0 | 5     | 86            |
| 9:20 AM                         | 0                       | 0    | 0     | 0 | 0                       | 1    | 0     | 0 | 0                        | 0    | 0     | 2 | 0                        | 0    | 0     | 0 | 3     | 77            |
| 9:25 AM                         | 1                       | 1    | 0     | 0 | 0                       | 0    | 0     | 0 | 0                        | 0    | 0     | 0 | 0                        | 1    | 0     | 0 | 3     | 68            |
| 9:30 AM                         | 2                       | 1    | 0     | 0 | 0                       | 4    | 0     | 0 | 0                        | 0    | 0     | 2 | 0                        | 0    | 0     | 0 | 9     | 69            |
| 9:35 AM                         | 1                       | 0    | 0     | 0 | 0                       | 1    | 1     | 0 | 0                        | 0    | 0     | 1 | 0                        | 0    | 0     | 0 | 4     | 69            |
| 9:40 AM                         | 0                       | 0    | 0     | 0 | 0                       | 0    | 0     | 0 | 0                        | 0    | 0     | 3 | 0                        | 2    | 0     | 0 | 5     | 69            |
| 9:45 AM                         | 1                       | 1    | 0     | 0 | 0                       | 1    | 0     | 0 | 0                        | 0    | 0     | 0 | 0                        | 0    | 0     | 0 | 3     | 64            |
| 9:50 AM                         | 2                       | 0    | 1     | 0 | 0                       | 0    | 0     | 0 | 0                        | 0    | 0     | 1 | 0                        | 0    | 0     | 0 | 4     | 61            |
| 9:55 AM                         | 2                       | 1    | 0     | 0 | 0                       | 3    | 0     | 0 | 0                        | 0    | 0     | 0 | 0                        | 0    | 0     | 0 | 6     | 62            |
| 10:00 AM                        | 0                       | 0    | 0     | 0 | 0                       | 1    | 0     | 0 | 0                        | 0    | 0     | 3 | 0                        | 0    | 0     | 0 | 4     | 59            |
| 10:05 AM                        | 1                       | 2    | 0     | 0 | 0                       | 1    | 0     | 0 | 0                        | 0    | 0     | 2 | 0                        | 0    | 0     | 0 | 6     | 59            |
| 10:10 AM                        | 0                       | 1    | 0     | 0 | 0                       | 1    | 0     | 0 | 0                        | 0    | 0     | 0 | 0                        | 1    | 0     | 0 | 3     | 55            |
| 10:15 AM                        | 1                       | 0    | 0     | 0 | 0                       | 0    | 0     | 0 | 0                        | 0    | 0     | 0 | 0                        | 0    | 0     | 0 | 1     | 51            |
| 10:20 AM                        | 1                       | 0    | 0     | 0 | 0                       | 2    | 0     | 0 | 0                        | 0    | 0     | 0 | 0                        | 0    | 0     | 0 | 3     | 51            |
| 10:25 AM                        | 0                       | 2    | 1     | 0 | 0                       | 0    | 0     | 0 | 0                        | 0    | 0     | 0 | 0                        | 0    | 0     | 0 | 3     | 51            |
| 10:30 AM                        | 0                       | 1    | 0     | 0 | 0                       | 1    | 0     | 0 | 0                        | 0    | 0     | 1 | 0                        | 1    | 0     | 0 | 4     | 46            |
| 10:35 AM                        | 0                       | 1    | 0     | 0 | 0                       | 2    | 0     | 0 | 0                        | 0    | 0     | 3 | 0                        | 0    | 0     | 0 | 6     | 48            |
| 10:40 AM                        | 1                       | 1    | 0     | 0 | 0                       | 0    | 0     | 0 | 0                        | 0    | 0     | 1 | 0                        | 0    | 0     | 0 | 3     | 46            |
| 10:45 AM                        | 1                       | 0    | 0     | 0 | 0                       | 4    | 0     | 0 | 0                        | 0    | 0     | 1 | 0                        | 0    | 0     | 0 | 6     | 49            |
| 10:50 AM                        | 0                       | 4    | 0     | 0 | 0                       | 1    | 0     | 0 | 0                        | 0    | 0     | 1 | 0                        | 0    | 0     | 0 | 6     | 51            |
| 10:55 AM                        | 0                       | 1    | 0     | 0 | 0                       | 0    | 0     | 0 | 0                        | 0    | 0     | 0 | 0                        | 0    | 0     | 0 | 1     | 46            |
| 11:00 AM                        | 0                       | 1    | 0     | 0 | 0                       | 2    | 0     | 0 | 0                        | 0    | 0     | 1 | 0                        | 1    | 0     | 0 | 5     | 47            |
| 11:05 AM                        | 1                       | 2    | 1     | 0 | 0                       | 3    | 0     | 0 | 0                        | 0    | 0     | 2 | 0                        | 1    | 0     | 0 | 10    | 51            |
| 11:10 AM                        | 1                       | 1    | 0     | 0 | 0                       | 2    | 0     | 0 | 0                        | 0    | 0     | 2 | 0                        | 0    | 0     | 0 | 6     | 54            |
| 11:15 AM                        | 2                       | 2    | 0     | 0 | 0                       | 1    | 0     | 0 | 0                        | 0    | 0     | 1 | 0                        | 0    | 0     | 0 | 6     | 59            |
| 11:20 AM                        | 0                       | 2    | 0     | 0 | 1                       | 0    | 0     | 0 | 0                        | 0    | 0     | 0 | 0                        | 0    | 0     | 0 | 3     | 59            |
| 11:25 AM                        | 1                       | 1    | 0     | 0 | 0                       | 1    | 0     | 0 | 0                        | 0    | 0     | 4 | 0                        | 0    | 1     | 0 | 8     | 64            |
| 11:30 AM                        | 0                       | 1    | 0     | 0 | 0                       | 1    | 0     | 0 | 0                        | 0    | 0     | 0 | 0                        | 0    | 0     | 1 | 3     | 63            |
| 11:35 AM                        | 1                       | 1    | 1     | 0 | 0                       | 1    | 0     | 0 | 0                        | 0    | 0     | 0 | 0                        | 0    | 0     | 0 | 4     | 61            |
| 11:40 AM                        | 0                       | 1    | 1     | 0 | 0                       | 1    | 0     | 0 | 0                        | 0    | 0     | 0 | 0                        | 0    | 0     | 0 | 3     | 61            |
| 11:45 AM                        | 0                       | 1    | 0     | 0 | 0                       | 4    | 0     | 0 | 0                        | 1    | 0     | 1 | 0                        | 0    | 0     | 0 | 7     | 62            |
| 11:50 AM                        | 0                       | 3    | 0     | 0 | 0                       | 1    | 0     | 0 | 0                        | 0    | 0     | 0 | 0                        | 0    | 0     | 0 | 4     | 60            |
| 11:55 AM                        | 1                       | 2    | 0     | 0 | 0                       | 2    | 0     | 0 | 0                        | 0    | 0     | 0 | 0                        | 1    | 0     | 0 | 6     | 65            |
| 12:00 PM                        | 1                       | 0    | 0     | 0 | 0                       | 2    | 0     | 0 | 0                        | 0    | 0     | 2 | 0                        | 0    | 0     | 0 | 5     | 65            |
| 12:05 PM                        | 0                       | 0    | 1     | 0 | 0                       | 1    | 0     | 0 | 0                        | 0    | 0     | 2 | 0                        | 0    | 0     | 0 | 4     | 59            |
| 12:10 PM                        | 0                       | 2    | 0     | 0 | 0                       | 0    | 0     | 0 | 0                        | 0    | 0     | 0 | 0                        | 0    | 0     | 0 | 2     | 55            |
| 12:15 PM                        | 1                       | 2    | 0     | 0 | 0                       | 4    | 0     | 0 | 0                        | 0    | 0     | 1 | 0                        | 1    | 0     | 0 | 9     | 58            |
| 12:20 PM                        | 1                       | 0    | 0     | 0 | 0                       | 2    | 0     | 0 | 0                        | 0    | 0     | 1 | 0                        | 0    | 0     | 0 | 4     | 59            |
| 12:25 PM                        | 4                       | 6    | 0     | 0 | 0                       | 3    | 0     | 0 | 0                        | 0    | 0     | 2 | 0                        | 0    | 0     | 0 | 15    | 66            |
| 12:30 PM                        | 2                       | 1    | 0     | 0 | 0                       | 2    | 0     | 0 | 0                        | 0    | 0     | 0 | 0                        | 0    | 0     | 0 | 5     | 68            |
| 12:35 PM                        | 0                       | 5    | 0     | 0 | 0                       | 0    | 0     | 0 | 0                        | 0    | 0     | 1 | 0                        | 0    | 0     | 0 | 6     | 70            |
| 12:40 PM                        | 1                       | 1    | 0     | 0 | 0                       | 1    | 0     | 0 | 0                        | 0    | 0     | 0 | 0                        | 0    | 0     | 0 | 3     | 70            |
| 12:45 PM                        | 1                       | 1    | 0     | 0 | 0                       | 1    | 0     | 0 | 0                        | 0    | 0     | 1 | 0                        | 0    | 0     | 0 | 4     | 67            |
| 12:50 PM                        | 0                       | 1    | 0     | 0 | 0                       | 0    | 0     | 0 | 0                        | 0    | 0     | 1 | 0                        | 0    | 0     | 0 | 2     | 65            |
| 12:55 PM                        | 1                       | 2    | 0     | 0 | 0                       | 0    | 0     | 0 | 0                        | 1    | 0     | 0 | 0                        | 0    | 0     | 0 | 4     | 63            |
| 1:00 PM                         | 0                       | 2    | 1     | 0 | 0                       | 3    | 1     | 0 | 0                        | 0    | 0     | 1 | 0                        | 0    | 0     | 0 | 8     | 66            |
| 1:05 PM                         | 1                       | 0    | 0     | 0 | 0                       | 2    | 1     | 0 | 0                        | 0    | 0     | 1 | 0                        | 1    | 0     | 1 | 7     | 69            |
| 1:10 PM                         | 2                       | 1    | 0     | 0 | 0                       | 1    | 0     | 0 | 0                        | 0    | 0     | 1 | 0                        | 0    | 0     | 0 | 5     | 72            |
| 1:15 PM                         | 0                       | 1    | 0     | 0 | 0                       | 0    | 0     | 0 | 0                        | 1    | 0     | 0 | 0                        | 0    | 0     | 0 | 2     | 65            |
| 1:20 PM                         | 1                       | 0    | 0     | 0 | 0                       | 2    | 0     | 0 | 0                        | 0    | 0     | 2 | 0                        | 2    | 0     | 0 | 7     | 68            |
| 1:25 PM                         | 1                       | 0    | 0     | 0 | 0                       | 4    | 0     | 0 | 0                        | 0    | 0     | 0 | 0                        | 0    | 0     | 0 | 5     | 58            |
| 1:30 PM                         | 0                       | 4    | 0     | 0 | 0                       | 3    | 0     | 0 | 0                        | 0    | 0     | 0 | 0                        | 0    | 0     | 0 | 7     | 60            |
| 1:35 PM                         | 1                       | 5    | 0     | 0 | 1                       | 3    | 0     | 0 | 0                        | 0    | 0     | 1 | 0                        | 0    | 0     | 0 | 11    | 65            |
| 1:40 PM                         | 1                       | 1    | 1     | 0 | 0                       | 0    | 0     | 0 | 0                        | 0    | 0     | 4 | 0                        | 1    | 0     | 0 | 8     | 70            |
| 1:45 PM                         | 0                       | 3    | 1     | 0 | 0                       | 1    | 0     | 0 | 0                        | 0    | 0     | 1 | 0                        | 0    | 0     | 0 | 6     | 72            |
| 1:50 PM                         | 1                       | 1    | 1     | 0 | 0                       | 4    | 0     | 0 | 0                        | 0    | 0     | 1 | 0                        | 0    | 0     | 0 | 8     | 78            |
| 1:55 PM                         | 1                       | 1    | 1     | 0 | 0                       | 1    | 0     | 0 | 0                        | 0    | 0     | 1 | 0                        | 0    | 0     | 0 | 5     | 79            |
| 2:00 PM                         | 1                       | 3    | 1     | 0 | 0                       | 2    | 0     | 0 | 0                        | 0    | 0     | 0 | 0                        | 0    | 0     | 0 | 7     | 78            |
| 2:05 PM                         | 1                       | 4    | 0     | 0 | 0                       | 2    | 0     | 0 | 0                        | 0    | 0     | 1 | 0                        | 0    | 0     | 0 | 8     | 79            |
| 2:10 PM                         | 1                       | 0    | 0     | 0 | 0                       | 0    | 0     | 0 | 0                        | 0    | 0     | 2 | 0                        | 0    | 0     | 1 | 4     | 78            |
| 2:15 PM                         | 0                       | 3    | 0     | 0 | 0                       | 2    | 0     | 0 | 0                        | 0    | 0     | 1 | 0                        | 0    | 0     | 0 | 6     | 82            |
| 2:20 PM                         | 1                       | 2    | 0     | 0 | 0                       | 3    | 0     | 0 | 0                        | 0    | 0     | 0 | 0                        | 0    | 0     | 0 | 6     | 81            |
| 2:25 PM                         | 0                       | 4    | 0     | 0 | 1                       | 5    | 0     | 0 | 0                        | 0    | 0     | 0 | 0                        | 0    | 0     | 0 | 10    | 86            |
| 2:30 PM                         | 0                       | 4    | 0     | 0 | 0                       | 1    | 0     | 0 | 0                        | 0    | 0     | 0 | 0                        | 1    | 0     | 0 | 6     | 85            |
| 2:35 PM                         | 2                       | 0    | 0     | 0 | 0                       | 1    | 2     | 0 | 0                        | 0    | 0     | 2 | 0                        | 0    | 0     | 0 | 7     | 81            |
| 2:40 PM                         | 0                       | 2    | 0     | 0 | 0                       | 3    | 0     | 0 | 0                        | 0    | 0     | 2 | 0                        | 0    | 0     | 0 | 7     | 80            |
| 2:45 PM                         | 0                       | 3    | 0     | 0 | 0                       | 0    | 0     | 0 | 0                        | 0    | 0     | 1 | 0                        | 0    | 0     | 0 | 4     | 78            |
| 2:50 PM                         | 1                       | 3    | 0     | 0 | 0                       | 2    | 0     | 0 | 0                        | 0    | 0     | 1 | 0                        | 0    | 0     | 0 | 7     | 77            |
| 2:55 PM                         | 1                       | 1    | 0     | 0 | 0                       | 4    | 0     | 0 | 0                        | 1    | 0     | 5 | 0                        | 0    | 0     | 0 | 12    | 84            |
| 3:00 PM                         | 0                       | 1    | 0     | 0 | 0                       | 2    | 0     | 0 | 0                        | 0    | 0     | 1 | 0                        | 0    | 0     | 0 | 4     | 81            |
| 3:05 PM                         | 0                       | 1    | 1     | 0 | 0                       | 1    | 0     | 0 | 0                        | 0    | 0     | 0 | 0                        | 0    | 0     | 0 | 3     | 76            |
| 3:10 PM                         | 0                       | 0    | 0     | 0 | 1                       | 0    | 0     | 0 | 0                        | 0    | 0     | 3 | 0                        | 0    | 0     | 0 | 4     | 76            |
| 3:15 PM                         | 1                       | 2    | 0     | 0 | 0                       | 3    | 0     | 0 | 0                        | 0    | 0     | 1 | 0                        | 0    | 0     | 0 | 7     | 77            |
| 3:20 PM                         | 0                       | 1    | 0     | 0 | 0                       | 3    | 0     | 0 | 0                        | 0    | 0     | 1 | 0                        | 1    | 0     | 0 | 6     | 77            |
| 3:25 PM                         | 2                       | 2    | 1     | 0 | 0                       | 2    | 0     | 0 | 0                        | 0    | 0     | 1 | 0                        | 0    | 0     | 0 | 8     | 75            |
| 3:30 PM                         | 0                       | 1    | 0     | 0 | 0                       | 3    | 0     | 0 | 0                        | 0    | 0     | 5 | 0                        | 1    | 0     | 0 | 10    | 79            |
| 3:35 PM                         | 0                       | 2    | 2     | 0 | 0                       | 0    | 0     | 0 | 0                        | 0    | 0     | 5 | 0                        | 0    | 0     | 0 | 9     | 81            |
| 3:40 PM                         | 1                       | 2    | 0     | 0 | 0                       | 2    | 0     | 0 | 0                        | 1    | 0     | 2 | 0                        | 1    | 1     | 0 | 10    | 84            |
| 3:45 PM                         | 2                       | 3    | 0     | 0 | 0                       | 3    | 0     | 0 | 0                        | 1    | 0     | 0 | 0                        | 1    | 0     | 0 | 10    | 90            |
| 3:50 PM                         | 1                       | 2    | 0     | 0 | 0                       | 0    | 1     | 0 | 0                        | 0    | 0     | 1 | 0                        | 0    | 0     | 0 | 5     | 88            |
| 3:55 PM                         | 2                       | 4    | 1     | 0 | 0                       | 0    | 0     | 0 | 0                        | 0    | 0     | 1 | 0                        | 0    | 0     | 0 | 8     | 84            |
| 4:00 PM                         | 3                       | 5    | 0     | 0 | 0                       | 3    | 0     | 0 | 0                        | 0    | 0     | 0 | 0                        | 0    | 0     | 0 | 11    | 91            |
| 4:05 PM                         | 1                       | 4    | 0     | 0 | 0                       | 2    | 0     | 0 | 0                        | 0    | 0     | 0 | 0                        | 0    | 0     | 0 | 7     | 95            |
| 4:10 PM                         | 3                       | 3    | 0     | 0 | 0                       | 2    | 0     | 0 | 0                        | 0    | 0     | 5 | 0                        | 0    | 0     | 0 | 13    | 104           |
| 4:15 PM                         | 2                       | 3    | 0     | 0 | 0                       | 0    | 0     | 0 | 0                        | 0    | 0     | 2 | 0                        | 0    | 0     | 0 | 7     | 104           |
| 4:20 PM                         | 3                       | 2    | 1     | 0 | 0                       | 1    | 0     | 0 | 0                        | 0    | 0     | 0 | 0                        | 0    | 0     | 0 | 7     | 105           |
| 4:25 PM                         | 4                       | 3    | 0     | 0 | 0                       | 1    | 0     | 0 | 0                        | 1    | 0     | 2 | 0                        | 1    | 0     | 0 | 12    | 109           |

**Attachment B**

| 5-Min Count Period Beginning At | Yardley St (Northbound) |      |       |   | Yardley St (Southbound) |      |       |   | S Harvest Ln (Eastbound) |      |       |    | S Harvest Ln (Westbound) |      |       |   | Total | Hourly Totals |
|---------------------------------|-------------------------|------|-------|---|-------------------------|------|-------|---|--------------------------|------|-------|----|--------------------------|------|-------|---|-------|---------------|
|                                 | Left                    | Thru | Right | U | Left                    | Thru | Right | U | Left                     | Thru | Right | U  | Left                     | Thru | Right | U |       |               |
| 4:30 PM                         | 2                       | 3    | 0     | 0 | 0                       | 1    | 0     | 0 | 0                        | 0    | 1     | 0  | 0                        | 0    | 0     | 0 | 7     | 106           |
| 4:35 PM                         | 4                       | 2    | 1     | 0 | 0                       | 1    | 0     | 0 | 0                        | 0    | 0     | 2  | 0                        | 0    | 0     | 0 | 10    | 107           |
| 4:40 PM                         | 1                       | 2    | 0     | 0 | 0                       | 2    | 0     | 0 | 0                        | 0    | 0     | 1  | 0                        | 0    | 0     | 0 | 6     | 103           |
| 4:45 PM                         | 0                       | 3    | 1     | 0 | 0                       | 2    | 0     | 0 | 0                        | 0    | 0     | 1  | 0                        | 1    | 0     | 0 | 8     | 101           |
| 4:50 PM                         | 1                       | 3    | 0     | 0 | 0                       | 3    | 1     | 0 | 0                        | 0    | 0     | 5  | 0                        | 0    | 0     | 0 | 13    | 109           |
| 4:55 PM                         | 2                       | 3    | 0     | 0 | 0                       | 3    | 0     | 0 | 0                        | 0    | 0     | 0  | 0                        | 0    | 0     | 0 | 8     | 109           |
| 5:00 PM                         | 1                       | 4    | 0     | 0 | 0                       | 1    | 1     | 0 | 0                        | 0    | 0     | 1  | 0                        | 0    | 0     | 0 | 8     | 106           |
| 5:05 PM                         | 2                       | 5    | 0     | 0 | 0                       | 1    | 0     | 0 | 0                        | 1    | 0     | 0  | 0                        | 1    | 0     | 0 | 10    | 109           |
| 5:10 PM                         | 2                       | 0    | 1     | 0 | 0                       | 3    | 0     | 0 | 0                        | 0    | 0     | 1  | 0                        | 0    | 0     | 0 | 7     | 103           |
| 5:15 PM                         | 0                       | 1    | 0     | 0 | 0                       | 1    | 0     | 0 | 0                        | 0    | 0     | 1  | 0                        | 1    | 0     | 0 | 4     | 100           |
| 5:20 PM                         | 0                       | 5    | 0     | 0 | 0                       | 1    | 0     | 0 | 0                        | 0    | 0     | 1  | 0                        | 0    | 0     | 0 | 7     | 100           |
| 5:25 PM                         | 1                       | 1    | 1     | 0 | 0                       | 4    | 0     | 0 | 0                        | 0    | 0     | 0  | 0                        | 0    | 0     | 0 | 7     | 95            |
| 5:30 PM                         | 1                       | 5    | 1     | 0 | 0                       | 4    | 0     | 0 | 0                        | 0    | 0     | 0  | 0                        | 0    | 0     | 0 | 11    | 99            |
| 5:35 PM                         | 0                       | 6    | 1     | 0 | 0                       | 0    | 0     | 0 | 0                        | 0    | 0     | 0  | 0                        | 0    | 0     | 0 | 7     | 96            |
| 5:40 PM                         | 1                       | 3    | 0     | 0 | 0                       | 1    | 0     | 0 | 0                        | 1    | 0     | 1  | 0                        | 0    | 0     | 0 | 7     | 97            |
| 5:45 PM                         | 0                       | 4    | 0     | 0 | 0                       | 0    | 0     | 0 | 0                        | 0    | 0     | 1  | 0                        | 0    | 0     | 0 | 5     | 94            |
| 5:50 PM                         | 2                       | 0    | 0     | 0 | 0                       | 2    | 0     | 0 | 0                        | 0    | 0     | 4  | 0                        | 1    | 0     | 0 | 9     | 90            |
| 5:55 PM                         | 3                       | 1    | 1     | 0 | 0                       | 1    | 0     | 0 | 0                        | 0    | 0     | 2  | 0                        | 1    | 0     | 0 | 9     | 91            |
| 6:00 PM                         | 1                       | 5    | 0     | 0 | 0                       | 3    | 0     | 0 | 0                        | 0    | 0     | 0  | 0                        | 0    | 0     | 0 | 9     | 92            |
| 6:05 PM                         | 2                       | 5    | 0     | 0 | 0                       | 2    | 0     | 0 | 0                        | 0    | 0     | 0  | 0                        | 0    | 0     | 0 | 9     | 91            |
| 6:10 PM                         | 1                       | 4    | 0     | 0 | 0                       | 2    | 0     | 0 | 0                        | 0    | 0     | 0  | 0                        | 0    | 0     | 0 | 7     | 91            |
| 6:15 PM                         | 1                       | 5    | 0     | 0 | 1                       | 3    | 0     | 0 | 0                        | 0    | 0     | 3  | 0                        | 1    | 0     | 0 | 14    | 101           |
| 6:20 PM                         | 1                       | 2    | 0     | 0 | 0                       | 2    | 1     | 0 | 0                        | 0    | 0     | 1  | 0                        | 0    | 0     | 0 | 7     | 101           |
| 6:25 PM                         | 0                       | 1    | 0     | 0 | 0                       | 2    | 0     | 0 | 0                        | 0    | 0     | 1  | 0                        | 0    | 0     | 0 | 4     | 98            |
| 6:30 PM                         | 3                       | 6    | 0     | 0 | 0                       | 1    | 0     | 0 | 0                        | 0    | 0     | 0  | 0                        | 0    | 0     | 0 | 10    | 97            |
| 6:35 PM                         | 0                       | 1    | 1     | 0 | 0                       | 4    | 0     | 0 | 0                        | 0    | 0     | 0  | 0                        | 0    | 0     | 0 | 6     | 96            |
| 6:40 PM                         | 1                       | 5    | 1     | 0 | 0                       | 0    | 0     | 0 | 0                        | 0    | 0     | 3  | 0                        | 0    | 0     | 0 | 10    | 99            |
| 6:45 PM                         | 2                       | 0    | 0     | 0 | 0                       | 2    | 0     | 0 | 0                        | 0    | 0     | 0  | 0                        | 0    | 0     | 0 | 4     | 98            |
| 6:50 PM                         | 1                       | 3    | 0     | 0 | 0                       | 2    | 0     | 0 | 0                        | 0    | 0     | 1  | 0                        | 1    | 0     | 0 | 8     | 97            |
| 6:55 PM                         | 3                       | 2    | 0     | 0 | 0                       | 3    | 0     | 0 | 0                        | 0    | 0     | 1  | 0                        | 0    | 0     | 0 | 9     | 97            |
| 7:00 PM                         | 2                       | 2    | 0     | 0 | 1                       | 3    | 0     | 0 | 0                        | 0    | 1     | 2  | 0                        | 1    | 1     | 0 | 13    | 101           |
| 7:05 PM                         | 1                       | 3    | 0     | 0 | 0                       | 1    | 0     | 0 | 0                        | 0    | 0     | 0  | 0                        | 0    | 0     | 0 | 5     | 97            |
| 7:10 PM                         | 0                       | 3    | 0     | 0 | 0                       | 0    | 0     | 0 | 0                        | 0    | 0     | 1  | 0                        | 0    | 0     | 0 | 4     | 94            |
| 7:15 PM                         | 0                       | 1    | 0     | 0 | 0                       | 1    | 0     | 0 | 0                        | 0    | 0     | 0  | 0                        | 0    | 0     | 0 | 2     | 82            |
| 7:20 PM                         | 0                       | 3    | 0     | 0 | 0                       | 1    | 0     | 0 | 0                        | 0    | 0     | 2  | 0                        | 0    | 0     | 0 | 6     | 81            |
| 7:25 PM                         | 1                       | 2    | 0     | 0 | 1                       | 1    | 0     | 0 | 0                        | 0    | 0     | 0  | 0                        | 0    | 0     | 1 | 6     | 83            |
| 7:30 PM                         | 0                       | 1    | 0     | 0 | 0                       | 1    | 0     | 0 | 0                        | 0    | 0     | 2  | 0                        | 0    | 0     | 0 | 4     | 77            |
| 7:35 PM                         | 1                       | 1    | 0     | 0 | 0                       | 0    | 0     | 0 | 0                        | 0    | 0     | 0  | 0                        | 0    | 0     | 0 | 2     | 73            |
| 7:40 PM                         | 1                       | 3    | 0     | 0 | 0                       | 0    | 0     | 0 | 0                        | 0    | 0     | 1  | 0                        | 0    | 0     | 0 | 5     | 68            |
| 7:45 PM                         | 1                       | 4    | 1     | 0 | 0                       | 2    | 0     | 0 | 0                        | 0    | 0     | 1  | 0                        | 0    | 0     | 0 | 9     | 73            |
| 7:50 PM                         | 1                       | 3    | 0     | 0 | 0                       | 2    | 0     | 0 | 0                        | 0    | 0     | 0  | 0                        | 1    | 0     | 0 | 7     | 72            |
| 7:55 PM                         | 3                       | 3    | 0     | 0 | 0                       | 1    | 0     | 0 | 0                        | 0    | 0     | 0  | 0                        | 0    | 0     | 0 | 7     | 70            |
| 8:00 PM                         | 4                       | 4    | 0     | 0 | 0                       | 1    | 0     | 0 | 0                        | 0    | 0     | 0  | 0                        | 0    | 0     | 0 | 9     | 66            |
| 8:05 PM                         | 1                       | 5    | 0     | 0 | 0                       | 2    | 0     | 0 | 0                        | 0    | 0     | 1  | 0                        | 0    | 0     | 0 | 9     | 70            |
| 8:10 PM                         | 2                       | 4    | 0     | 0 | 0                       | 2    | 1     | 0 | 0                        | 0    | 0     | 2  | 0                        | 1    | 0     | 0 | 12    | 78            |
| 8:15 PM                         | 0                       | 2    | 1     | 0 | 1                       | 0    | 0     | 0 | 0                        | 0    | 0     | 2  | 0                        | 0    | 0     | 0 | 6     | 82            |
| 8:20 PM                         | 2                       | 5    | 1     | 0 | 0                       | 0    | 0     | 0 | 0                        | 0    | 0     | 0  | 0                        | 1    | 0     | 0 | 9     | 85            |
| 8:25 PM                         | 2                       | 2    | 0     | 0 | 0                       | 1    | 0     | 0 | 0                        | 0    | 0     | 2  | 0                        | 0    | 0     | 0 | 7     | 86            |
| 8:30 PM                         | 0                       | 0    | 0     | 0 | 0                       | 0    | 0     | 0 | 0                        | 0    | 0     | 0  | 0                        | 0    | 0     | 0 | 0     | 82            |
| 8:35 PM                         | 1                       | 2    | 0     | 0 | 0                       | 1    | 0     | 0 | 0                        | 1    | 0     | 1  | 0                        | 0    | 0     | 0 | 6     | 86            |
| 8:40 PM                         | 3                       | 0    | 1     | 0 | 0                       | 1    | 0     | 0 | 0                        | 0    | 0     | 1  | 0                        | 0    | 0     | 0 | 6     | 87            |
| 8:45 PM                         | 2                       | 3    | 2     | 0 | 0                       | 0    | 0     | 0 | 0                        | 0    | 0     | 0  | 0                        | 0    | 0     | 0 | 7     | 85            |
| 8:50 PM                         | 0                       | 3    | 2     | 0 | 0                       | 1    | 0     | 0 | 0                        | 0    | 0     | 0  | 0                        | 0    | 0     | 0 | 6     | 84            |
| 8:55 PM                         | 0                       | 2    | 0     | 0 | 0                       | 4    | 0     | 0 | 0                        | 0    | 0     | 1  | 0                        | 1    | 0     | 0 | 8     | 85            |
| 9:00 PM                         | 0                       | 0    | 0     | 0 | 0                       | 0    | 0     | 0 | 0                        | 0    | 0     | 1  | 0                        | 0    | 0     | 0 | 1     | 77            |
| 9:05 PM                         | 0                       | 0    | 0     | 0 | 0                       | 4    | 0     | 0 | 0                        | 0    | 0     | 0  | 0                        | 0    | 0     | 0 | 4     | 72            |
| 9:10 PM                         | 1                       | 1    | 0     | 0 | 0                       | 0    | 0     | 0 | 0                        | 0    | 0     | 2  | 0                        | 0    | 0     | 0 | 4     | 64            |
| 9:15 PM                         | 0                       | 3    | 1     | 0 | 0                       | 2    | 0     | 0 | 0                        | 0    | 0     | 0  | 0                        | 0    | 0     | 0 | 6     | 64            |
| 9:20 PM                         | 0                       | 1    | 0     | 0 | 0                       | 2    | 0     | 0 | 0                        | 0    | 0     | 0  | 0                        | 1    | 1     | 0 | 5     | 60            |
| 9:25 PM                         | 0                       | 1    | 1     | 0 | 0                       | 1    | 0     | 0 | 0                        | 0    | 0     | 0  | 0                        | 0    | 0     | 0 | 3     | 56            |
| 9:30 PM                         | 2                       | 2    | 0     | 0 | 0                       | 0    | 0     | 0 | 0                        | 0    | 0     | 0  | 0                        | 0    | 0     | 0 | 4     | 60            |
| 9:35 PM                         | 1                       | 0    | 0     | 0 | 0                       | 1    | 0     | 0 | 0                        | 0    | 0     | 2  | 0                        | 0    | 0     | 0 | 4     | 58            |
| 9:40 PM                         | 1                       | 4    | 0     | 0 | 0                       | 0    | 0     | 0 | 0                        | 0    | 0     | 1  | 0                        | 0    | 0     | 0 | 6     | 58            |
| 9:45 PM                         | 1                       | 4    | 0     | 0 | 0                       | 2    | 0     | 0 | 0                        | 0    | 2     | 0  | 0                        | 1    | 0     | 0 | 10    | 61            |
| 9:50 PM                         | 0                       | 0    | 0     | 0 | 0                       | 1    | 0     | 0 | 0                        | 0    | 0     | 0  | 0                        | 0    | 0     | 0 | 1     | 56            |
| 9:55 PM                         | 1                       | 1    | 0     | 0 | 0                       | 0    | 0     | 0 | 0                        | 0    | 0     | 1  | 0                        | 0    | 0     | 0 | 4     | 52            |
| Peak 15-Min Flowrates           | Northbound              |      |       |   | Southbound              |      |       |   | Eastbound                |      |       |    | Westbound                |      |       |   | Total |               |
|                                 | Left                    | Thru | Right | U | Left                    | Thru | Right | U | Left                     | Thru | Right | U  | Left                     | Thru | Right | U |       |               |
| All Vehicles                    | 28                      | 48   | 0     | 0 | 0                       | 28   | 0     | 0 | 0                        | 0    | 0     | 20 | 0                        | 0    | 0     | 0 | 124   |               |
| Heavy Trucks                    | 0                       | 0    | 0     |   | 0                       | 4    | 0     |   | 0                        | 0    | 0     |    |                          | 0    | 0     |   | 4     |               |
| Buses                           |                         | 4    |       |   |                         | 8    |       |   |                          | 4    |       |    |                          | 4    |       |   | 20    |               |
| Pedestrians                     |                         |      |       |   |                         |      |       |   |                          |      |       |    |                          |      |       |   | 0     |               |
| Bicycles                        | 0                       | 0    | 0     |   | 0                       | 0    | 0     |   | 0                        | 0    | 0     |    | 0                        | 0    | 0     |   | 0     |               |
| Scooters                        |                         |      |       |   |                         |      |       |   |                          |      |       |    |                          |      |       |   |       |               |

Comments:

Type of peak hour being reported: Intersection Peak

Method for determining peak hour: Total Entering Volume

LOCATION: Wendover Rd -- Shadow Hill Dr  
 CITY/STATE: Orange, CA

QC JOB #: 16966431  
 DATE: Wed, Apr 9 2025

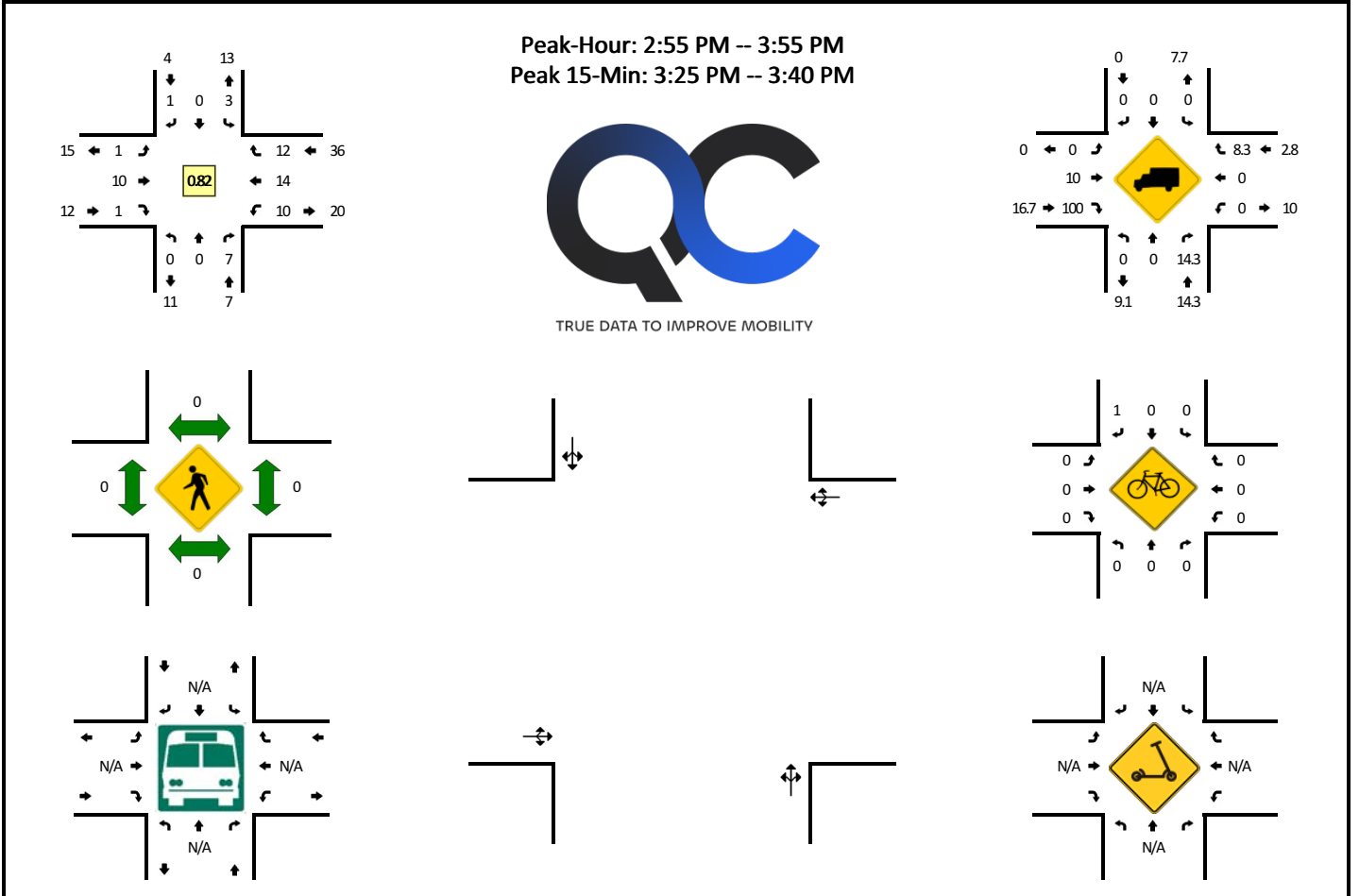

| 5-Min Count Period Beginning At | Wendover Rd (Northbound) |      |       |   | Wendover Rd (Southbound) |      |       |   | Shadow Hill Dr (Eastbound) |      |       |   | Shadow Hill Dr (Westbound) |      |       |   | Total | Hourly Totals |
|---------------------------------|--------------------------|------|-------|---|--------------------------|------|-------|---|----------------------------|------|-------|---|----------------------------|------|-------|---|-------|---------------|
|                                 | Left                     | Thru | Right | U | Left                     | Thru | Right | U | Left                       | Thru | Right | U | Left                       | Thru | Right | U |       |               |
| 6:00 AM                         | 0                        | 0    | 0     | 0 | 1                        | 0    | 0     | 0 | 0                          | 0    | 0     | 0 | 0                          | 0    | 1     | 0 | 2     |               |
| 6:05 AM                         | 0                        | 0    | 0     | 0 | 1                        | 0    | 0     | 0 | 0                          | 0    | 0     | 0 | 0                          | 0    | 0     | 0 | 1     |               |
| 6:10 AM                         | 0                        | 0    | 0     | 0 | 0                        | 0    | 0     | 0 | 0                          | 0    | 0     | 0 | 0                          | 0    | 0     | 0 | 0     |               |
| 6:15 AM                         | 0                        | 0    | 0     | 0 | 1                        | 0    | 0     | 0 | 0                          | 0    | 0     | 0 | 0                          | 0    | 0     | 0 | 1     |               |
| 6:20 AM                         | 0                        | 0    | 2     | 0 | 0                        | 0    | 0     | 0 | 0                          | 0    | 1     | 0 | 0                          | 0    | 0     | 0 | 3     |               |
| 6:25 AM                         | 0                        | 0    | 1     | 0 | 0                        | 0    | 0     | 0 | 0                          | 0    | 0     | 0 | 1                          | 0    | 0     | 0 | 2     |               |
| 6:30 AM                         | 0                        | 0    | 1     | 0 | 0                        | 0    | 0     | 0 | 0                          | 0    | 1     | 0 | 0                          | 0    | 0     | 0 | 2     |               |
| 6:35 AM                         | 0                        | 0    | 0     | 0 | 2                        | 0    | 0     | 0 | 0                          | 0    | 1     | 0 | 0                          | 0    | 0     | 0 | 3     |               |
| 6:40 AM                         | 0                        | 0    | 0     | 0 | 0                        | 0    | 0     | 0 | 0                          | 0    | 0     | 0 | 0                          | 0    | 0     | 0 | 0     |               |
| 6:45 AM                         | 0                        | 0    | 1     | 0 | 0                        | 0    | 0     | 0 | 0                          | 0    | 0     | 0 | 1                          | 0    | 0     | 0 | 2     |               |
| 6:50 AM                         | 0                        | 0    | 1     | 0 | 0                        | 0    | 0     | 0 | 0                          | 0    | 0     | 0 | 0                          | 0    | 0     | 0 | 1     |               |
| 6:55 AM                         | 0                        | 0    | 0     | 0 | 1                        | 0    | 0     | 0 | 0                          | 0    | 0     | 0 | 0                          | 0    | 0     | 0 | 1     | 18            |
| 7:00 AM                         | 0                        | 0    | 0     | 0 | 1                        | 0    | 0     | 0 | 0                          | 0    | 0     | 0 | 0                          | 0    | 0     | 0 | 1     | 17            |
| 7:05 AM                         | 0                        | 0    | 0     | 0 | 0                        | 0    | 0     | 0 | 0                          | 0    | 1     | 0 | 0                          | 0    | 0     | 0 | 1     | 17            |
| 7:10 AM                         | 0                        | 0    | 0     | 0 | 0                        | 0    | 0     | 0 | 0                          | 0    | 0     | 0 | 1                          | 0    | 0     | 0 | 1     | 18            |
| 7:15 AM                         | 0                        | 0    | 0     | 0 | 1                        | 0    | 0     | 0 | 0                          | 0    | 0     | 0 | 0                          | 0    | 0     | 0 | 1     | 18            |
| 7:20 AM                         | 0                        | 0    | 0     | 0 | 1                        | 0    | 0     | 0 | 0                          | 0    | 0     | 0 | 0                          | 0    | 0     | 0 | 1     | 16            |
| 7:25 AM                         | 0                        | 0    | 0     | 0 | 0                        | 0    | 0     | 0 | 0                          | 0    | 1     | 0 | 0                          | 0    | 0     | 0 | 1     | 15            |
| 7:30 AM                         | 0                        | 0    | 0     | 0 | 1                        | 0    | 0     | 0 | 0                          | 0    | 2     | 0 | 0                          | 0    | 0     | 0 | 3     | 16            |
| 7:35 AM                         | 0                        | 0    | 3     | 0 | 2                        | 0    | 0     | 0 | 0                          | 0    | 0     | 0 | 0                          | 0    | 0     | 0 | 5     | 18            |
| 7:40 AM                         | 0                        | 0    | 1     | 0 | 0                        | 0    | 0     | 0 | 0                          | 0    | 1     | 0 | 0                          | 0    | 1     | 0 | 3     | 21            |
| 7:45 AM                         | 0                        | 0    | 0     | 0 | 1                        | 0    | 0     | 0 | 0                          | 0    | 1     | 0 | 0                          | 1    | 1     | 0 | 4     | 23            |
| 7:50 AM                         | 0                        | 0    | 0     | 0 | 1                        | 0    | 0     | 0 | 0                          | 0    | 1     | 0 | 0                          | 1    | 0     | 1 | 4     | 26            |
| 7:55 AM                         | 0                        | 0    | 2     | 0 | 1                        | 0    | 0     | 0 | 0                          | 0    | 2     | 0 | 0                          | 2    | 0     | 0 | 7     | 32            |
| 8:00 AM                         | 0                        | 0    | 0     | 0 | 0                        | 0    | 0     | 0 | 0                          | 0    | 0     | 0 | 0                          | 1    | 3     | 0 | 4     | 35            |
| 8:05 AM                         | 0                        | 0    | 1     | 0 | 1                        | 0    | 0     | 0 | 0                          | 0    | 1     | 0 | 0                          | 2    | 0     | 0 | 5     | 39            |
| 8:10 AM                         | 0                        | 0    | 2     | 0 | 2                        | 0    | 0     | 0 | 0                          | 0    | 1     | 1 | 0                          | 1    | 0     | 1 | 8     | 46            |
| 8:15 AM                         | 1                        | 0    | 0     | 0 | 0                        | 0    | 0     | 0 | 0                          | 0    | 0     | 0 | 0                          | 0    | 0     | 0 | 1     | 46            |
| 8:20 AM                         | 0                        | 0    | 0     | 0 | 1                        | 0    | 0     | 0 | 0                          | 0    | 0     | 0 | 0                          | 2    | 0     | 0 | 3     | 48            |
| 8:25 AM                         | 0                        | 0    | 0     | 0 | 1                        | 0    | 0     | 0 | 0                          | 0    | 0     | 0 | 0                          | 0    | 0     | 0 | 1     | 48            |
| 8:30 AM                         | 0                        | 0    | 1     | 0 | 0                        | 0    | 0     | 0 | 0                          | 0    | 1     | 0 | 0                          | 0    | 0     | 0 | 2     | 47            |
| 8:35 AM                         | 0                        | 0    | 2     | 0 | 1                        | 0    | 0     | 0 | 0                          | 0    | 0     | 0 | 1                          | 1    | 1     | 0 | 6     | 48            |
| 8:40 AM                         | 0                        | 0    | 0     | 0 | 1                        | 0    | 0     | 0 | 0                          | 0    | 0     | 0 | 0                          | 0    | 0     | 0 | 1     | 46            |
| 8:45 AM                         | 0                        | 0    | 3     | 0 | 0                        | 0    | 0     | 0 | 0                          | 0    | 1     | 0 | 0                          | 2    | 1     | 2 | 9     | 51            |
| 8:50 AM                         | 0                        | 0    | 0     | 0 | 0                        | 0    | 0     | 0 | 0                          | 0    | 3     | 0 | 0                          | 0    | 0     | 1 | 4     | 51            |
| 8:55 AM                         | 0                        | 0    | 0     | 0 | 0                        | 0    | 0     | 0 | 0                          | 0    | 1     | 0 | 0                          | 0    | 1     | 1 | 3     | 47            |
| 9:00 AM                         | 0                        | 0    | 1     | 0 | 1                        | 0    | 0     | 0 | 0                          | 0    | 0     | 0 | 0                          | 0    | 1     | 0 | 3     | 46            |
| 9:05 AM                         | 0                        | 0    | 1     | 0 | 1                        | 0    | 0     | 0 | 0                          | 0    | 2     | 0 | 0                          | 0    | 0     | 0 | 4     | 45            |

**Attachment B**

| 5-Min Count Period Beginning At | Wendover Rd (Northbound) |      |       |   | Wendover Rd (Southbound) |      |       |   | Shadow Hill Dr (Eastbound) |      |       |   | Shadow Hill Dr (Westbound) |      |       |   | Total | Hourly Totals |
|---------------------------------|--------------------------|------|-------|---|--------------------------|------|-------|---|----------------------------|------|-------|---|----------------------------|------|-------|---|-------|---------------|
|                                 | Left                     | Thru | Right | U | Left                     | Thru | Right | U | Left                       | Thru | Right | U | Left                       | Thru | Right | U |       |               |
| 9:10 AM                         | 0                        | 0    | 0     | 0 | 0                        | 0    | 0     | 0 | 0                          | 0    | 0     | 0 | 0                          | 0    | 1     | 0 | 1     | 38            |
| 9:15 AM                         | 0                        | 0    | 0     | 0 | 1                        | 0    | 0     | 0 | 0                          | 0    | 0     | 0 | 0                          | 0    | 0     | 0 | 1     | 38            |
| 9:20 AM                         | 0                        | 0    | 0     | 0 | 1                        | 0    | 0     | 0 | 0                          | 0    | 1     | 0 | 0                          | 0    | 0     | 0 | 2     | 37            |
| 9:25 AM                         | 0                        | 0    | 0     | 0 | 1                        | 0    | 0     | 0 | 0                          | 0    | 0     | 0 | 0                          | 0    | 0     | 0 | 1     | 37            |
| 9:30 AM                         | 0                        | 0    | 0     | 0 | 0                        | 0    | 0     | 0 | 0                          | 0    | 0     | 0 | 0                          | 1    | 0     | 0 | 1     | 36            |
| 9:35 AM                         | 0                        | 0    | 0     | 0 | 0                        | 0    | 0     | 0 | 0                          | 0    | 0     | 0 | 0                          | 2    | 1     | 0 | 3     | 33            |
| 9:40 AM                         | 0                        | 0    | 1     | 0 | 1                        | 0    | 0     | 0 | 0                          | 0    | 0     | 0 | 0                          | 0    | 0     | 0 | 2     | 34            |
| 9:45 AM                         | 0                        | 0    | 1     | 0 | 0                        | 0    | 0     | 0 | 0                          | 0    | 1     | 0 | 0                          | 0    | 1     | 1 | 4     | 29            |
| 9:50 AM                         | 0                        | 0    | 1     | 0 | 0                        | 0    | 0     | 0 | 0                          | 0    | 0     | 0 | 0                          | 0    | 1     | 0 | 2     | 27            |
| 9:55 AM                         | 0                        | 0    | 0     | 0 | 0                        | 0    | 0     | 0 | 0                          | 0    | 1     | 0 | 0                          | 1    | 1     | 2 | 5     | 29            |
| 10:00 AM                        | 0                        | 0    | 0     | 0 | 0                        | 0    | 0     | 0 | 0                          | 0    | 0     | 0 | 0                          | 0    | 0     | 0 | 0     | 26            |
| 10:05 AM                        | 0                        | 0    | 1     | 0 | 2                        | 0    | 0     | 0 | 0                          | 0    | 0     | 1 | 0                          | 1    | 0     | 1 | 6     | 28            |
| 10:10 AM                        | 0                        | 0    | 2     | 0 | 2                        | 1    | 0     | 0 | 0                          | 0    | 0     | 1 | 0                          | 1    | 1     | 0 | 9     | 36            |
| 10:15 AM                        | 0                        | 0    | 1     | 0 | 0                        | 0    | 0     | 0 | 0                          | 0    | 1     | 0 | 0                          | 0    | 0     | 0 | 2     | 37            |
| 10:20 AM                        | 1                        | 0    | 2     | 0 | 1                        | 1    | 0     | 0 | 0                          | 0    | 0     | 0 | 0                          | 1    | 0     | 0 | 6     | 41            |
| 10:25 AM                        | 0                        | 0    | 1     | 0 | 1                        | 0    | 0     | 0 | 0                          | 0    | 0     | 0 | 0                          | 0    | 1     | 0 | 3     | 43            |
| 10:30 AM                        | 0                        | 0    | 2     | 0 | 1                        | 0    | 0     | 0 | 0                          | 0    | 0     | 0 | 0                          | 2    | 1     | 0 | 6     | 48            |
| 10:35 AM                        | 0                        | 0    | 1     | 0 | 1                        | 0    | 0     | 0 | 0                          | 0    | 1     | 0 | 0                          | 0    | 0     | 0 | 3     | 48            |
| 10:40 AM                        | 0                        | 0    | 0     | 0 | 2                        | 0    | 0     | 0 | 0                          | 0    | 1     | 0 | 0                          | 1    | 0     | 1 | 5     | 51            |
| 10:45 AM                        | 0                        | 0    | 1     | 0 | 0                        | 0    | 0     | 0 | 0                          | 0    | 1     | 0 | 0                          | 0    | 1     | 0 | 3     | 50            |
| 10:50 AM                        | 0                        | 0    | 1     | 0 | 0                        | 0    | 0     | 0 | 0                          | 0    | 2     | 0 | 0                          | 0    | 1     | 0 | 4     | 52            |
| 10:55 AM                        | 0                        | 0    | 0     | 0 | 0                        | 0    | 0     | 0 | 0                          | 0    | 0     | 0 | 0                          | 1    | 0     | 1 | 2     | 49            |
| 11:00 AM                        | 0                        | 0    | 1     | 0 | 2                        | 0    | 0     | 0 | 0                          | 0    | 3     | 0 | 0                          | 0    | 0     | 1 | 7     | 56            |
| 11:05 AM                        | 0                        | 0    | 0     | 0 | 1                        | 0    | 0     | 0 | 0                          | 0    | 0     | 0 | 0                          | 1    | 0     | 0 | 2     | 52            |
| 11:10 AM                        | 0                        | 0    | 0     | 0 | 0                        | 0    | 0     | 0 | 0                          | 0    | 0     | 0 | 0                          | 0    | 0     | 0 | 0     | 43            |
| 11:15 AM                        | 0                        | 0    | 0     | 0 | 0                        | 0    | 0     | 0 | 0                          | 0    | 1     | 0 | 0                          | 1    | 1     | 0 | 3     | 44            |
| 11:20 AM                        | 0                        | 0    | 0     | 0 | 1                        | 0    | 0     | 0 | 0                          | 0    | 0     | 0 | 0                          | 1    | 1     | 0 | 3     | 41            |
| 11:25 AM                        | 0                        | 0    | 1     | 0 | 1                        | 1    | 0     | 0 | 0                          | 0    | 0     | 0 | 0                          | 0    | 1     | 0 | 4     | 42            |
| 11:30 AM                        | 0                        | 1    | 0     | 0 | 2                        | 0    | 0     | 0 | 0                          | 0    | 1     | 0 | 0                          | 1    | 1     | 0 | 6     | 42            |
| 11:35 AM                        | 0                        | 0    | 1     | 0 | 0                        | 0    | 0     | 0 | 0                          | 0    | 2     | 0 | 0                          | 0    | 0     | 1 | 4     | 43            |
| 11:40 AM                        | 0                        | 0    | 1     | 0 | 0                        | 0    | 0     | 0 | 0                          | 0    | 1     | 0 | 0                          | 0    | 1     | 0 | 3     | 41            |
| 11:45 AM                        | 0                        | 0    | 1     | 0 | 1                        | 0    | 0     | 0 | 0                          | 0    | 2     | 0 | 0                          | 1    | 1     | 1 | 7     | 45            |
| 11:50 AM                        | 0                        | 0    | 0     | 0 | 0                        | 0    | 0     | 0 | 0                          | 0    | 0     | 0 | 0                          | 0    | 1     | 0 | 1     | 42            |
| 11:55 AM                        | 0                        | 0    | 0     | 0 | 1                        | 0    | 0     | 0 | 0                          | 0    | 0     | 0 | 0                          | 0    | 1     | 0 | 2     | 42            |
| 12:00 PM                        | 1                        | 0    | 0     | 0 | 0                        | 1    | 0     | 0 | 0                          | 0    | 0     | 0 | 0                          | 2    | 1     | 0 | 5     | 40            |
| 12:05 PM                        | 1                        | 0    | 0     | 0 | 1                        | 0    | 0     | 0 | 0                          | 0    | 0     | 0 | 0                          | 1    | 1     | 0 | 4     | 42            |
| 12:10 PM                        | 0                        | 0    | 0     | 0 | 0                        | 0    | 0     | 0 | 0                          | 0    | 1     | 0 | 0                          | 0    | 1     | 1 | 3     | 45            |
| 12:15 PM                        | 0                        | 0    | 0     | 0 | 1                        | 0    | 0     | 0 | 0                          | 0    | 0     | 0 | 0                          | 1    | 0     | 1 | 3     | 45            |
| 12:20 PM                        | 0                        | 0    | 0     | 0 | 0                        | 0    | 0     | 0 | 0                          | 0    | 0     | 0 | 0                          | 0    | 0     | 0 | 0     | 42            |
| 12:25 PM                        | 0                        | 0    | 0     | 0 | 1                        | 0    | 0     | 0 | 0                          | 0    | 1     | 0 | 0                          | 1    | 0     | 1 | 4     | 42            |
| 12:30 PM                        | 0                        | 0    | 1     | 0 | 1                        | 0    | 0     | 0 | 0                          | 0    | 4     | 0 | 0                          | 1    | 0     | 1 | 8     | 44            |
| 12:35 PM                        | 0                        | 0    | 0     | 0 | 0                        | 0    | 0     | 0 | 0                          | 0    | 2     | 0 | 0                          | 0    | 1     | 0 | 3     | 43            |
| 12:40 PM                        | 0                        | 0    | 0     | 0 | 0                        | 0    | 0     | 0 | 0                          | 0    | 0     | 0 | 0                          | 0    | 1     | 0 | 1     | 41            |
| 12:45 PM                        | 0                        | 0    | 1     | 0 | 1                        | 0    | 0     | 0 | 0                          | 0    | 0     | 0 | 0                          | 0    | 2     | 0 | 4     | 38            |
| 12:50 PM                        | 0                        | 0    | 0     | 0 | 0                        | 0    | 0     | 0 | 0                          | 0    | 0     | 0 | 0                          | 1    | 0     | 0 | 1     | 38            |
| 12:55 PM                        | 0                        | 0    | 0     | 0 | 2                        | 0    | 0     | 0 | 0                          | 0    | 1     | 0 | 0                          | 0    | 1     | 0 | 4     | 40            |
| 1:00 PM                         | 0                        | 0    | 0     | 0 | 0                        | 0    | 0     | 0 | 0                          | 0    | 3     | 0 | 0                          | 0    | 1     | 0 | 4     | 39            |
| 1:05 PM                         | 0                        | 0    | 0     | 0 | 2                        | 0    | 0     | 0 | 0                          | 0    | 0     | 0 | 0                          | 1    | 1     | 0 | 4     | 39            |
| 1:10 PM                         | 1                        | 0    | 1     | 0 | 0                        | 0    | 0     | 0 | 0                          | 0    | 2     | 0 | 0                          | 0    | 1     | 1 | 6     | 42            |
| 1:15 PM                         | 0                        | 0    | 0     | 0 | 1                        | 0    | 0     | 0 | 0                          | 0    | 0     | 0 | 0                          | 0    | 1     | 0 | 2     | 41            |
| 1:20 PM                         | 0                        | 0    | 0     | 0 | 2                        | 0    | 0     | 0 | 0                          | 0    | 1     | 0 | 0                          | 0    | 0     | 2 | 5     | 46            |
| 1:25 PM                         | 0                        | 0    | 0     | 0 | 1                        | 0    | 0     | 0 | 0                          | 0    | 0     | 0 | 0                          | 0    | 1     | 1 | 3     | 45            |
| 1:30 PM                         | 0                        | 0    | 0     | 0 | 1                        | 0    | 0     | 0 | 0                          | 0    | 0     | 0 | 0                          | 0    | 2     | 2 | 5     | 42            |
| 1:35 PM                         | 0                        | 0    | 0     | 0 | 1                        | 0    | 0     | 0 | 0                          | 0    | 0     | 0 | 0                          | 1    | 1     | 1 | 4     | 43            |
| 1:40 PM                         | 0                        | 0    | 2     | 0 | 0                        | 0    | 0     | 0 | 0                          | 0    | 2     | 0 | 0                          | 1    | 1     | 0 | 6     | 48            |
| 1:45 PM                         | 0                        | 0    | 1     | 0 | 1                        | 0    | 0     | 0 | 0                          | 0    | 0     | 0 | 0                          | 0    | 1     | 1 | 4     | 48            |
| 1:50 PM                         | 0                        | 0    | 0     | 0 | 1                        | 0    | 0     | 0 | 0                          | 0    | 0     | 0 | 0                          | 0    | 0     | 0 | 1     | 48            |
| 1:55 PM                         | 0                        | 0    | 0     | 0 | 0                        | 0    | 0     | 0 | 0                          | 0    | 0     | 0 | 0                          | 0    | 1     | 2 | 3     | 47            |
| 2:00 PM                         | 0                        | 0    | 0     | 0 | 0                        | 0    | 0     | 0 | 0                          | 0    | 0     | 0 | 0                          | 0    | 1     | 1 | 2     | 45            |
| 2:05 PM                         | 0                        | 0    | 0     | 0 | 0                        | 0    | 0     | 0 | 0                          | 0    | 0     | 0 | 0                          | 1    | 0     | 1 | 2     | 43            |
| 2:10 PM                         | 0                        | 0    | 1     | 0 | 1                        | 0    | 0     | 0 | 0                          | 0    | 0     | 0 | 0                          | 0    | 0     | 0 | 2     | 39            |
| 2:15 PM                         | 0                        | 0    | 1     | 0 | 0                        | 0    | 0     | 0 | 0                          | 0    | 0     | 0 | 0                          | 0    | 0     | 0 | 1     | 38            |
| 2:20 PM                         | 0                        | 0    | 0     | 0 | 0                        | 0    | 0     | 0 | 0                          | 0    | 1     | 0 | 0                          | 0    | 2     | 0 | 3     | 36            |
| 2:25 PM                         | 0                        | 0    | 0     | 0 | 0                        | 0    | 0     | 0 | 0                          | 0    | 3     | 0 | 0                          | 0    | 0     | 0 | 3     | 36            |
| 2:30 PM                         | 0                        | 0    | 0     | 0 | 1                        | 0    | 0     | 0 | 0                          | 0    | 1     | 0 | 0                          | 0    | 0     | 0 | 2     | 33            |
| 2:35 PM                         | 0                        | 0    | 0     | 0 | 0                        | 0    | 0     | 0 | 0                          | 0    | 0     | 0 | 0                          | 0    | 0     | 2 | 2     | 31            |
| 2:40 PM                         | 0                        | 0    | 0     | 0 | 0                        | 0    | 0     | 0 | 0                          | 0    | 0     | 0 | 0                          | 1    | 2     | 2 | 5     | 30            |
| 2:45 PM                         | 0                        | 0    | 0     | 0 | 2                        | 0    | 0     | 0 | 0                          | 0    | 2     | 0 | 0                          | 0    | 0     | 1 | 5     | 31            |
| 2:50 PM                         | 0                        | 0    | 0     | 0 | 0                        | 0    | 0     | 0 | 0                          | 0    | 0     | 0 | 0                          | 0    | 1     | 0 | 1     | 31            |
| 2:55 PM                         | 0                        | 0    | 0     | 0 | 0                        | 0    | 0     | 0 | 0                          | 1    | 2     | 0 | 0                          | 3    | 0     | 1 | 7     | 35            |
| 3:00 PM                         | 0                        | 0    | 0     | 0 | 0                        | 0    | 0     | 0 | 0                          | 0    | 1     | 0 | 0                          | 0    | 1     | 1 | 3     | 36            |
| 3:05 PM                         | 0                        | 0    | 0     | 0 | 0                        | 0    | 0     | 0 | 0                          | 0    | 1     | 0 | 0                          | 0    | 1     | 2 | 4     | 38            |
| 3:10 PM                         | 0                        | 0    | 1     | 0 | 0                        | 0    | 0     | 0 | 0                          | 0    | 0     | 0 | 0                          | 1    | 0     | 2 | 4     | 40            |
| 3:15 PM                         | 0                        | 0    | 1     | 0 | 0                        | 0    | 0     | 0 | 0                          | 0    | 0     | 0 | 0                          | 0    | 2     | 1 | 4     | 43            |
| 3:20 PM                         | 0                        | 0    | 0     | 0 | 0                        | 0    | 0     | 0 | 0                          | 0    | 3     | 0 | 0                          | 1    | 2     | 1 | 7     | 47            |
| 3:25 PM                         | 0                        | 0    | 2     | 0 | 1                        | 0    | 0     | 0 | 0                          | 0    | 0     | 0 | 0                          | 0    | 2     | 0 | 5     | 49            |
| 3:30 PM                         | 0                        | 0    | 0     | 0 | 0                        | 0    | 1     | 0 | 0                          | 0    | 1     | 0 | 0                          | 0    | 0     | 1 | 3     | 50            |
| 3:35 PM                         | 0                        | 0    | 1     | 0 | 1                        | 0    | 0     | 0 | 0                          | 0    | 1     | 1 | 0                          | 2    | 2     | 2 | 10    | 58            |
| 3:40 PM                         | 0                        | 0    | 1     | 0 | 0                        | 0    | 0     | 0 | 0                          | 0    | 0     | 0 | 0                          | 3    | 1     | 0 | 5     | 58            |
| 3:45 PM                         | 0                        | 0    | 1     | 0 | 1                        | 0    | 0     | 0 | 0                          | 0    | 0     | 0 | 0                          | 0    | 1     | 0 | 3     | 56            |
| 3:50 PM                         | 0                        | 0    | 0     | 0 | 0                        | 0    | 0     | 0 | 0                          | 0    | 1     | 0 | 0                          | 0    | 2     | 1 | 4     | 59            |
| 3:55 PM                         | 0                        | 0    | 1     | 0 | 0                        | 1    | 0     | 0 | 0                          | 0    | 0     | 0 | 0                          | 0    | 0     | 0 | 2     | 54            |
| 4:00 PM                         | 0                        | 0    | 0     | 0 | 1                        | 0    | 0     | 0 | 0                          | 0    | 3     | 0 | 0                          | 0    | 1     | 1 | 6     | 57            |
| 4:05 PM                         | 0                        | 0    | 1     | 0 | 0                        | 0    | 0     | 0 | 0                          | 0    | 0     | 0 | 0                          | 0    | 0     | 0 | 1     | 54            |
| 4:10 PM                         | 0                        | 0    | 0     | 0 | 0                        | 0    | 0     | 0 | 0                          | 0    | 0     | 0 | 0                          | 3    | 1     | 0 | 4     | 54            |
| 4:15 PM                         | 0                        | 0    | 0     | 0 | 0                        | 0    | 0     | 0 | 0                          | 0    | 0     | 0 | 0                          | 1    | 3     | 0 | 4     | 54            |
| 4:20 PM                         | 0                        | 0    | 0     | 0 | 0                        | 0    | 0     | 0 | 0                          | 0    | 1     | 0 | 0                          | 1    | 0     | 0 | 2     | 49            |
| 4:25 PM                         | 0                        | 0    | 0     | 0 | 1                        | 0    | 0     | 0 | 0                          | 0    | 1     | 0 | 0                          | 0    | 1     | 1 | 4     | 48            |

**Attachment B**

| 5-Min Count Period Beginning At | Wendover Rd (Northbound) |      |       |   | Wendover Rd (Southbound) |      |       |   | Shadow Hill Dr (Eastbound) |      |       |   | Shadow Hill Dr (Westbound) |      |       |   | Total | Hourly Totals |
|---------------------------------|--------------------------|------|-------|---|--------------------------|------|-------|---|----------------------------|------|-------|---|----------------------------|------|-------|---|-------|---------------|
|                                 | Left                     | Thru | Right | U | Left                     | Thru | Right | U | Left                       | Thru | Right | U | Left                       | Thru | Right | U |       |               |
| 4:30 PM                         | 0                        | 0    | 0     | 0 | 0                        | 0    | 0     | 0 | 0                          | 0    | 0     | 0 | 0                          | 0    | 1     | 0 | 1     | 46            |
| 4:35 PM                         | 0                        | 0    | 0     | 0 | 0                        | 0    | 0     | 0 | 0                          | 0    | 0     | 0 | 0                          | 1    | 0     | 0 | 1     | 37            |
| 4:40 PM                         | 0                        | 0    | 0     | 0 | 1                        | 0    | 0     | 0 | 0                          | 0    | 0     | 0 | 0                          | 0    | 1     | 0 | 2     | 34            |
| 4:45 PM                         | 0                        | 0    | 1     | 0 | 0                        | 0    | 0     | 0 | 0                          | 1    | 0     | 0 | 0                          | 1    | 1     | 0 | 4     | 35            |
| 4:50 PM                         | 0                        | 0    | 0     | 0 | 1                        | 0    | 0     | 0 | 0                          | 2    | 0     | 0 | 1                          | 2    | 1     | 0 | 7     | 38            |
| 4:55 PM                         | 0                        | 0    | 0     | 0 | 0                        | 0    | 0     | 0 | 0                          | 1    | 0     | 0 | 0                          | 0    | 0     | 0 | 1     | 37            |
| 5:00 PM                         | 0                        | 0    | 0     | 0 | 1                        | 0    | 0     | 0 | 0                          | 0    | 0     | 0 | 1                          | 0    | 0     | 0 | 2     | 33            |
| 5:05 PM                         | 0                        | 0    | 0     | 0 | 0                        | 0    | 0     | 0 | 0                          | 1    | 0     | 0 | 1                          | 1    | 0     | 0 | 3     | 35            |
| 5:10 PM                         | 0                        | 0    | 0     | 0 | 1                        | 0    | 0     | 0 | 0                          | 0    | 0     | 0 | 0                          | 0    | 0     | 0 | 1     | 32            |
| 5:15 PM                         | 0                        | 0    | 0     | 0 | 1                        | 0    | 0     | 0 | 0                          | 0    | 1     | 0 | 0                          | 0    | 1     | 0 | 3     | 31            |
| 5:20 PM                         | 0                        | 0    | 0     | 0 | 0                        | 0    | 0     | 0 | 0                          | 2    | 0     | 0 | 1                          | 0    | 3     | 0 | 6     | 35            |
| 5:25 PM                         | 0                        | 0    | 0     | 0 | 1                        | 0    | 0     | 0 | 0                          | 0    | 0     | 0 | 0                          | 1    | 1     | 0 | 3     | 34            |
| 5:30 PM                         | 0                        | 0    | 0     | 0 | 0                        | 0    | 0     | 0 | 0                          | 1    | 0     | 0 | 0                          | 2    | 0     | 0 | 3     | 36            |
| 5:35 PM                         | 0                        | 0    | 0     | 0 | 1                        | 0    | 0     | 0 | 0                          | 0    | 0     | 0 | 1                          | 1    | 0     | 0 | 3     | 38            |
| 5:40 PM                         | 0                        | 0    | 0     | 0 | 2                        | 0    | 0     | 0 | 0                          | 0    | 0     | 0 | 1                          | 0    | 0     | 0 | 3     | 39            |
| 5:45 PM                         | 1                        | 0    | 0     | 0 | 0                        | 0    | 0     | 0 | 0                          | 1    | 0     | 0 | 2                          | 0    | 0     | 0 | 4     | 39            |
| 5:50 PM                         | 0                        | 0    | 0     | 0 | 1                        | 0    | 0     | 0 | 0                          | 0    | 0     | 0 | 1                          | 0    | 0     | 0 | 2     | 34            |
| 5:55 PM                         | 0                        | 0    | 1     | 0 | 0                        | 0    | 0     | 0 | 0                          | 0    | 0     | 0 | 0                          | 0    | 1     | 0 | 2     | 35            |
| 6:00 PM                         | 0                        | 0    | 1     | 0 | 0                        | 0    | 0     | 0 | 0                          | 1    | 0     | 0 | 1                          | 1    | 0     | 0 | 4     | 37            |
| 6:05 PM                         | 0                        | 0    | 1     | 0 | 2                        | 0    | 0     | 0 | 0                          | 0    | 0     | 0 | 0                          | 0    | 1     | 0 | 4     | 38            |
| 6:10 PM                         | 0                        | 0    | 1     | 0 | 0                        | 0    | 0     | 0 | 0                          | 0    | 1     | 0 | 0                          | 1    | 1     | 0 | 4     | 41            |
| 6:15 PM                         | 0                        | 0    | 1     | 0 | 1                        | 0    | 0     | 0 | 0                          | 1    | 0     | 0 | 0                          | 0    | 0     | 0 | 3     | 41            |
| 6:20 PM                         | 0                        | 0    | 0     | 0 | 0                        | 0    | 0     | 0 | 0                          | 0    | 2     | 0 | 0                          | 0    | 0     | 0 | 2     | 37            |
| 6:25 PM                         | 1                        | 2    | 0     | 0 | 0                        | 0    | 0     | 0 | 0                          | 0    | 0     | 0 | 0                          | 2    | 0     | 0 | 5     | 39            |
| 6:30 PM                         | 0                        | 0    | 2     | 0 | 0                        | 0    | 1     | 0 | 0                          | 0    | 0     | 0 | 1                          | 1    | 0     | 0 | 5     | 41            |
| 6:35 PM                         | 0                        | 0    | 1     | 0 | 1                        | 0    | 0     | 0 | 0                          | 0    | 0     | 0 | 0                          | 0    | 3     | 0 | 5     | 43            |
| 6:40 PM                         | 0                        | 0    | 0     | 0 | 2                        | 0    | 0     | 0 | 1                          | 0    | 0     | 0 | 2                          | 0    | 2     | 0 | 7     | 47            |
| 6:45 PM                         | 0                        | 0    | 0     | 0 | 0                        | 0    | 0     | 0 | 0                          | 0    | 0     | 0 | 0                          | 0    | 0     | 0 | 0     | 43            |
| 6:50 PM                         | 0                        | 0    | 0     | 0 | 0                        | 0    | 0     | 0 | 0                          | 0    | 0     | 0 | 0                          | 1    | 1     | 0 | 2     | 43            |
| 6:55 PM                         | 0                        | 0    | 0     | 0 | 1                        | 0    | 0     | 0 | 0                          | 1    | 0     | 0 | 0                          | 1    | 2     | 0 | 5     | 46            |
| 7:00 PM                         | 0                        | 0    | 0     | 0 | 0                        | 0    | 0     | 0 | 0                          | 1    | 0     | 0 | 1                          | 1    | 1     | 0 | 4     | 46            |
| 7:05 PM                         | 0                        | 0    | 0     | 0 | 1                        | 0    | 0     | 0 | 0                          | 0    | 0     | 0 | 0                          | 1    | 1     | 0 | 3     | 45            |
| 7:10 PM                         | 0                        | 0    | 1     | 0 | 0                        | 0    | 0     | 0 | 0                          | 1    | 0     | 0 | 0                          | 0    | 1     | 0 | 3     | 44            |
| 7:15 PM                         | 0                        | 0    | 0     | 0 | 0                        | 0    | 0     | 0 | 0                          | 0    | 1     | 0 | 0                          | 0    | 0     | 0 | 1     | 42            |
| 7:20 PM                         | 0                        | 2    | 1     | 0 | 0                        | 0    | 0     | 0 | 1                          | 0    | 0     | 0 | 0                          | 0    | 0     | 0 | 4     | 44            |
| 7:25 PM                         | 0                        | 0    | 0     | 0 | 1                        | 1    | 0     | 0 | 0                          | 0    | 0     | 0 | 1                          | 0    | 0     | 0 | 3     | 42            |
| 7:30 PM                         | 0                        | 0    | 0     | 0 | 0                        | 0    | 0     | 0 | 0                          | 0    | 0     | 0 | 2                          | 0    | 0     | 0 | 2     | 39            |
| 7:35 PM                         | 0                        | 0    | 0     | 0 | 0                        | 0    | 0     | 0 | 0                          | 0    | 0     | 0 | 0                          | 0    | 0     | 0 | 0     | 34            |
| 7:40 PM                         | 0                        | 0    | 0     | 0 | 1                        | 0    | 0     | 0 | 0                          | 0    | 0     | 0 | 1                          | 1    | 1     | 0 | 4     | 31            |
| 7:45 PM                         | 0                        | 0    | 0     | 0 | 0                        | 0    | 0     | 0 | 0                          | 1    | 0     | 0 | 0                          | 0    | 0     | 0 | 1     | 32            |
| 7:50 PM                         | 0                        | 0    | 0     | 0 | 2                        | 0    | 0     | 0 | 0                          | 0    | 0     | 0 | 0                          | 0    | 0     | 0 | 2     | 32            |
| 7:55 PM                         | 0                        | 0    | 1     | 0 | 0                        | 0    | 0     | 0 | 0                          | 0    | 0     | 0 | 0                          | 1    | 0     | 0 | 2     | 29            |
| 8:00 PM                         | 0                        | 0    | 1     | 0 | 1                        | 0    | 0     | 0 | 0                          | 0    | 0     | 0 | 0                          | 2    | 1     | 0 | 5     | 30            |
| 8:05 PM                         | 0                        | 0    | 0     | 0 | 0                        | 0    | 0     | 0 | 0                          | 0    | 0     | 0 | 0                          | 1    | 0     | 0 | 1     | 28            |
| 8:10 PM                         | 0                        | 0    | 0     | 0 | 0                        | 0    | 0     | 0 | 0                          | 0    | 0     | 0 | 0                          | 0    | 2     | 0 | 2     | 27            |
| 8:15 PM                         | 0                        | 0    | 0     | 0 | 0                        | 0    | 0     | 0 | 0                          | 1    | 0     | 0 | 0                          | 0    | 1     | 0 | 2     | 28            |
| 8:20 PM                         | 0                        | 0    | 0     | 0 | 0                        | 0    | 0     | 0 | 0                          | 0    | 0     | 0 | 2                          | 0    | 2     | 0 | 4     | 28            |
| 8:25 PM                         | 0                        | 0    | 0     | 0 | 0                        | 0    | 1     | 0 | 0                          | 1    | 0     | 0 | 0                          | 0    | 1     | 0 | 3     | 28            |
| 8:30 PM                         | 0                        | 0    | 0     | 0 | 0                        | 0    | 0     | 0 | 0                          | 1    | 0     | 0 | 0                          | 0    | 0     | 0 | 1     | 27            |
| 8:35 PM                         | 0                        | 0    | 0     | 0 | 0                        | 0    | 0     | 0 | 0                          | 0    | 0     | 0 | 0                          | 1    | 1     | 0 | 2     | 29            |
| 8:40 PM                         | 0                        | 0    | 1     | 0 | 0                        | 0    | 0     | 0 | 0                          | 1    | 1     | 0 | 1                          | 2    | 1     | 0 | 7     | 32            |
| 8:45 PM                         | 0                        | 0    | 0     | 0 | 0                        | 0    | 0     | 0 | 0                          | 0    | 0     | 0 | 2                          | 0    | 1     | 0 | 3     | 34            |
| 8:50 PM                         | 0                        | 0    | 2     | 0 | 0                        | 0    | 0     | 0 | 0                          | 0    | 0     | 0 | 1                          | 1    | 1     | 0 | 5     | 37            |
| 8:55 PM                         | 0                        | 0    | 0     | 0 | 1                        | 0    | 0     | 0 | 0                          | 0    | 0     | 0 | 0                          | 1    | 0     | 0 | 2     | 37            |
| 9:00 PM                         | 0                        | 0    | 0     | 0 | 0                        | 0    | 0     | 0 | 0                          | 0    | 0     | 0 | 1                          | 0    | 1     | 0 | 2     | 34            |
| 9:05 PM                         | 0                        | 0    | 0     | 0 | 0                        | 0    | 0     | 0 | 0                          | 0    | 0     | 0 | 0                          | 0    | 0     | 0 | 0     | 33            |
| 9:10 PM                         | 0                        | 0    | 0     | 0 | 0                        | 0    | 0     | 0 | 0                          | 1    | 0     | 0 | 0                          | 2    | 0     | 0 | 3     | 34            |
| 9:15 PM                         | 0                        | 0    | 0     | 0 | 1                        | 0    | 0     | 0 | 0                          | 0    | 0     | 0 | 0                          | 1    | 1     | 0 | 3     | 35            |
| 9:20 PM                         | 0                        | 0    | 0     | 0 | 0                        | 0    | 0     | 0 | 0                          | 1    | 0     | 0 | 0                          | 0    | 1     | 0 | 2     | 33            |
| 9:25 PM                         | 0                        | 0    | 0     | 0 | 0                        | 0    | 0     | 0 | 0                          | 0    | 0     | 0 | 0                          | 0    | 0     | 0 | 0     | 30            |
| 9:30 PM                         | 0                        | 0    | 0     | 0 | 0                        | 0    | 0     | 0 | 0                          | 0    | 0     | 0 | 0                          | 0    | 1     | 0 | 1     | 30            |
| 9:35 PM                         | 0                        | 0    | 0     | 0 | 0                        | 0    | 0     | 0 | 0                          | 0    | 0     | 0 | 0                          | 0    | 0     | 0 | 0     | 28            |
| 9:40 PM                         | 0                        | 0    | 0     | 0 | 0                        | 0    | 0     | 0 | 0                          | 0    | 0     | 0 | 0                          | 0    | 0     | 0 | 0     | 21            |
| 9:45 PM                         | 0                        | 0    | 0     | 0 | 0                        | 0    | 0     | 0 | 0                          | 1    | 0     | 0 | 0                          | 0    | 0     | 0 | 1     | 19            |
| 9:50 PM                         | 0                        | 0    | 0     | 0 | 0                        | 0    | 0     | 0 | 0                          | 0    | 0     | 0 | 1                          | 0    | 0     | 0 | 1     | 15            |
| 9:55 PM                         | 0                        | 0    | 0     | 0 | 0                        | 0    | 0     | 0 | 0                          | 0    | 0     | 0 | 0                          | 0    | 1     | 0 | 1     | 14            |
| Peak 15-Min Flowrates           | Northbound               |      |       |   | Southbound               |      |       |   | Eastbound                  |      |       |   | Westbound                  |      |       |   | Total |               |
|                                 | Left                     | Thru | Right | U | Left                     | Thru | Right | U | Left                       | Thru | Right | U | Left                       | Thru | Right | U |       |               |
| All Vehicles                    | 0                        | 0    | 12    | 0 | 8                        | 0    | 4     | 0 | 0                          | 8    | 4     | 0 | 8                          | 16   | 12    | 0 | 72    |               |
| Heavy Trucks                    | 0                        | 0    | 0     |   | 0                        | 0    | 0     |   | 0                          | 0    | 4     |   | 0                          | 0    | 4     |   | 8     |               |
| Buses                           |                          |      |       |   |                          |      |       |   |                            |      |       |   |                            |      |       |   |       |               |
| Pedestrians                     |                          | 0    |       |   |                          | 0    |       |   |                            | 0    |       |   |                            | 0    |       |   | 0     |               |
| Bicycles                        | 0                        | 0    | 0     |   | 0                        | 0    | 0     |   | 0                          | 0    | 0     |   | 0                          | 0    | 0     |   | 0     |               |
| Scoters                         |                          |      |       |   |                          |      |       |   |                            |      |       |   |                            |      |       |   |       |               |

Comments:

LOCATION: Colony Dr -- La Loma Dr  
 CITY/STATE: North Tustin, CA

QC JOB #: 16966432  
 DATE: Thu, Apr 10 2025

Peak-Hour: 7:30 AM -- 8:30 AM  
 Peak 15-Min: 7:50 AM -- 8:05 AM

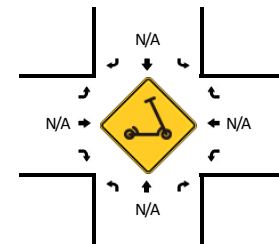
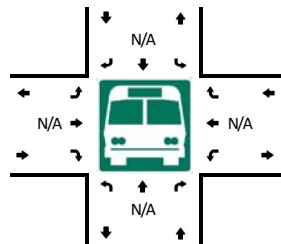
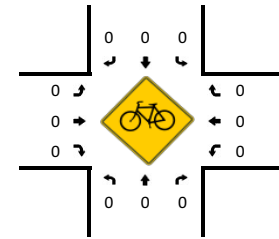
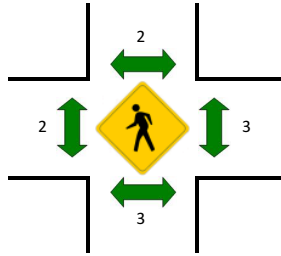
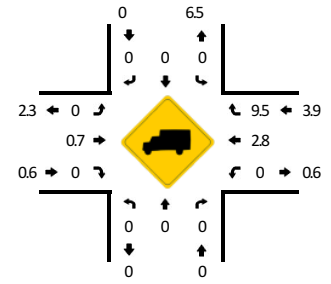
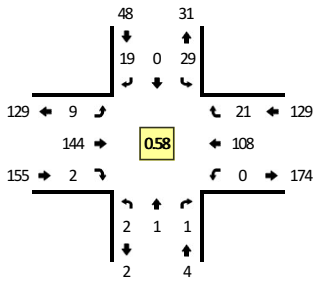

| 5-Min Count Period Beginning At | Colony Dr (Northbound) |      |       |   | Colony Dr (Southbound) |      |       |   | La Loma Dr (Eastbound) |      |       |   | La Loma Dr (Westbound) |      |       |   | Total | Hourly Totals |     |
|---------------------------------|------------------------|------|-------|---|------------------------|------|-------|---|------------------------|------|-------|---|------------------------|------|-------|---|-------|---------------|-----|
|                                 | Left                   | Thru | Right | U | Left                   | Thru | Right | U | Left                   | Thru | Right | U | Left                   | Thru | Right | U |       |               |     |
| 6:00 AM                         | 0                      | 0    | 0     | 0 | 0                      | 0    | 0     | 0 | 0                      | 0    | 0     | 0 | 0                      | 1    | 1     | 0 | 0     | 2             |     |
| 6:05 AM                         | 0                      | 0    | 0     | 0 | 0                      | 0    | 0     | 0 | 0                      | 0    | 0     | 0 | 0                      | 0    | 0     | 0 | 0     | 0             | 0   |
| 6:10 AM                         | 1                      | 0    | 0     | 0 | 0                      | 0    | 0     | 0 | 0                      | 0    | 0     | 0 | 0                      | 0    | 0     | 0 | 0     | 1             |     |
| 6:15 AM                         | 0                      | 0    | 0     | 0 | 0                      | 0    | 0     | 0 | 0                      | 1    | 0     | 0 | 0                      | 0    | 0     | 0 | 0     | 1             |     |
| 6:20 AM                         | 0                      | 0    | 0     | 0 | 1                      | 0    | 0     | 0 | 0                      | 0    | 0     | 0 | 0                      | 0    | 0     | 0 | 0     | 1             |     |
| 6:25 AM                         | 0                      | 0    | 0     | 0 | 0                      | 0    | 1     | 0 | 0                      | 1    | 0     | 0 | 0                      | 1    | 0     | 0 | 0     | 3             |     |
| 6:30 AM                         | 0                      | 0    | 0     | 0 | 2                      | 0    | 1     | 0 | 0                      | 0    | 0     | 0 | 0                      | 3    | 1     | 0 | 0     | 7             |     |
| 6:35 AM                         | 0                      | 0    | 0     | 0 | 1                      | 0    | 0     | 0 | 0                      | 2    | 1     | 0 | 0                      | 1    | 0     | 0 | 0     | 5             |     |
| 6:40 AM                         | 0                      | 0    | 0     | 0 | 1                      | 0    | 0     | 0 | 0                      | 2    | 0     | 0 | 0                      | 2    | 0     | 0 | 0     | 5             |     |
| 6:45 AM                         | 0                      | 0    | 0     | 0 | 0                      | 0    | 0     | 0 | 0                      | 1    | 3     | 0 | 0                      | 0    | 0     | 0 | 0     | 4             |     |
| 6:50 AM                         | 0                      | 0    | 0     | 0 | 0                      | 0    | 0     | 0 | 0                      | 0    | 3     | 0 | 0                      | 0    | 1     | 1 | 0     | 5             |     |
| 6:55 AM                         | 0                      | 0    | 1     | 0 | 0                      | 0    | 0     | 0 | 0                      | 2    | 0     | 0 | 0                      | 1    | 0     | 0 | 0     | 4             | 38  |
| 7:00 AM                         | 0                      | 0    | 0     | 0 | 1                      | 0    | 0     | 0 | 0                      | 1    | 2     | 0 | 0                      | 5    | 1     | 0 | 0     | 10            | 46  |
| 7:05 AM                         | 0                      | 0    | 0     | 0 | 2                      | 0    | 0     | 0 | 0                      | 1    | 1     | 0 | 0                      | 7    | 4     | 0 | 0     | 14            | 60  |
| 7:10 AM                         | 0                      | 0    | 0     | 0 | 0                      | 0    | 0     | 0 | 0                      | 6    | 0     | 0 | 0                      | 5    | 1     | 0 | 0     | 13            | 72  |
| 7:15 AM                         | 0                      | 0    | 0     | 0 | 3                      | 0    | 1     | 0 | 0                      | 4    | 0     | 0 | 0                      | 2    | 0     | 0 | 0     | 10            | 81  |
| 7:20 AM                         | 0                      | 0    | 0     | 0 | 1                      | 0    | 0     | 0 | 0                      | 2    | 0     | 0 | 0                      | 4    | 1     | 0 | 0     | 8             | 88  |
| 7:25 AM                         | 0                      | 0    | 0     | 0 | 3                      | 0    | 1     | 0 | 0                      | 3    | 0     | 0 | 0                      | 2    | 0     | 0 | 0     | 9             | 94  |
| 7:30 AM                         | 0                      | 0    | 0     | 0 | 1                      | 0    | 0     | 0 | 0                      | 7    | 0     | 0 | 0                      | 4    | 1     | 0 | 0     | 13            | 100 |
| 7:35 AM                         | 0                      | 0    | 0     | 0 | 1                      | 0    | 0     | 0 | 0                      | 3    | 7     | 0 | 0                      | 3    | 1     | 0 | 0     | 15            | 110 |
| 7:40 AM                         | 1                      | 0    | 0     | 0 | 3                      | 0    | 2     | 0 | 0                      | 14   | 0     | 0 | 0                      | 0    | 3     | 0 | 0     | 23            | 128 |
| 7:45 AM                         | 0                      | 0    | 0     | 0 | 2                      | 0    | 4     | 0 | 0                      | 30   | 0     | 0 | 0                      | 4    | 2     | 0 | 0     | 42            | 166 |
| 7:50 AM                         | 1                      | 0    | 0     | 0 | 5                      | 0    | 1     | 0 | 1                      | 23   | 0     | 0 | 0                      | 12   | 2     | 0 | 0     | 45            | 206 |
| 7:55 AM                         | 0                      | 0    | 0     | 0 | 6                      | 0    | 2     | 0 | 2                      | 22   | 2     | 0 | 0                      | 17   | 0     | 0 | 0     | 51            | 253 |
| 8:00 AM                         | 0                      | 0    | 0     | 0 | 6                      | 0    | 4     | 0 | 0                      | 13   | 0     | 0 | 0                      | 21   | 4     | 0 | 0     | 48            | 291 |
| 8:05 AM                         | 0                      | 1    | 1     | 0 | 0                      | 0    | 0     | 0 | 0                      | 4    | 0     | 0 | 0                      | 17   | 3     | 0 | 0     | 26            | 303 |
| 8:10 AM                         | 0                      | 0    | 0     | 0 | 2                      | 0    | 1     | 0 | 1                      | 2    | 0     | 0 | 0                      | 9    | 1     | 0 | 0     | 16            | 306 |
| 8:15 AM                         | 0                      | 0    | 0     | 0 | 2                      | 0    | 1     | 0 | 1                      | 7    | 0     | 0 | 0                      | 8    | 2     | 0 | 0     | 21            | 317 |
| 8:20 AM                         | 0                      | 0    | 0     | 0 | 0                      | 0    | 1     | 0 | 1                      | 5    | 0     | 0 | 0                      | 7    | 1     | 0 | 0     | 15            | 324 |
| 8:25 AM                         | 0                      | 0    | 0     | 0 | 1                      | 0    | 3     | 0 | 0                      | 10   | 0     | 0 | 0                      | 6    | 1     | 0 | 0     | 21            | 336 |
| 8:30 AM                         | 0                      | 0    | 0     | 0 | 1                      | 0    | 2     | 0 | 1                      | 3    | 0     | 0 | 0                      | 1    | 1     | 0 | 0     | 9             | 332 |
| 8:35 AM                         | 1                      | 0    | 0     | 0 | 0                      | 0    | 1     | 0 | 0                      | 0    | 0     | 0 | 0                      | 2    | 0     | 0 | 0     | 4             | 321 |
| 8:40 AM                         | 0                      | 0    | 1     | 0 | 3                      | 0    | 0     | 0 | 0                      | 1    | 0     | 0 | 1                      | 3    | 1     | 0 | 0     | 10            | 308 |
| 8:45 AM                         | 0                      | 0    | 0     | 0 | 0                      | 0    | 0     | 0 | 1                      | 1    | 0     | 0 | 0                      | 2    | 0     | 0 | 0     | 4             | 270 |
| 8:50 AM                         | 0                      | 0    | 0     | 0 | 4                      | 0    | 1     | 0 | 1                      | 4    | 0     | 0 | 0                      | 1    | 0     | 0 | 0     | 11            | 236 |
| 8:55 AM                         | 0                      | 0    | 0     | 0 | 6                      | 0    | 0     | 0 | 0                      | 4    | 0     | 0 | 0                      | 4    | 2     | 0 | 0     | 16            | 201 |
| 9:00 AM                         | 0                      | 0    | 1     | 0 | 2                      | 0    | 2     | 0 | 2                      | 4    | 0     | 0 | 0                      | 0    | 1     | 0 | 0     | 12            | 165 |
| 9:05 AM                         | 0                      | 0    | 0     | 0 | 1                      | 0    | 2     | 0 | 1                      | 4    | 0     | 0 | 0                      | 3    | 2     | 0 | 0     | 13            | 152 |

**Attachment B**

| 5-Min Count Period Beginning At | Colony Dr (Northbound) |      |       |   | Colony Dr (Southbound) |      |       |   | La Loma Dr (Eastbound) |      |       |   | La Loma Dr (Westbound) |      |       |   | Total | Hourly Totals |
|---------------------------------|------------------------|------|-------|---|------------------------|------|-------|---|------------------------|------|-------|---|------------------------|------|-------|---|-------|---------------|
|                                 | Left                   | Thru | Right | U | Left                   | Thru | Right | U | Left                   | Thru | Right | U | Left                   | Thru | Right | U |       |               |
| 9:10 AM                         | 0                      | 0    | 0     | 0 | 1                      | 0    | 1     | 0 | 0                      | 4    | 0     | 0 | 0                      | 1    | 2     | 0 | 9     | 145           |
| 9:15 AM                         | 0                      | 0    | 0     | 0 | 2                      | 0    | 0     | 0 | 1                      | 1    | 0     | 0 | 0                      | 0    | 6     | 0 | 10    | 134           |
| 9:20 AM                         | 0                      | 0    | 0     | 0 | 2                      | 0    | 0     | 0 | 1                      | 1    | 0     | 0 | 0                      | 0    | 5     | 0 | 9     | 128           |
| 9:25 AM                         | 0                      | 0    | 0     | 0 | 0                      | 0    | 0     | 0 | 0                      | 2    | 0     | 0 | 0                      | 0    | 1     | 0 | 3     | 110           |
| 9:30 AM                         | 0                      | 0    | 1     | 0 | 0                      | 0    | 1     | 0 | 0                      | 2    | 0     | 0 | 0                      | 0    | 2     | 2 | 8     | 109           |
| 9:35 AM                         | 0                      | 0    | 0     | 0 | 0                      | 0    | 0     | 0 | 0                      | 4    | 0     | 0 | 0                      | 0    | 4     | 2 | 10    | 115           |
| 9:40 AM                         | 0                      | 0    | 0     | 0 | 0                      | 0    | 1     | 0 | 0                      | 2    | 0     | 0 | 0                      | 0    | 2     | 0 | 5     | 110           |
| 9:45 AM                         | 0                      | 0    | 0     | 0 | 2                      | 0    | 2     | 0 | 0                      | 0    | 0     | 0 | 0                      | 0    | 4     | 0 | 8     | 114           |
| 9:50 AM                         | 0                      | 0    | 0     | 0 | 2                      | 0    | 0     | 0 | 0                      | 3    | 0     | 0 | 0                      | 0    | 0     | 0 | 5     | 108           |
| 9:55 AM                         | 0                      | 0    | 0     | 0 | 1                      | 0    | 0     | 0 | 0                      | 3    | 0     | 0 | 0                      | 0    | 2     | 1 | 7     | 99            |
| 10:00 AM                        | 0                      | 0    | 0     | 0 | 1                      | 0    | 0     | 0 | 0                      | 3    | 0     | 0 | 0                      | 0    | 1     | 2 | 7     | 94            |
| 10:05 AM                        | 1                      | 0    | 0     | 0 | 0                      | 0    | 1     | 0 | 1                      | 3    | 0     | 0 | 0                      | 0    | 2     | 0 | 8     | 89            |
| 10:10 AM                        | 0                      | 0    | 0     | 0 | 3                      | 0    | 1     | 0 | 0                      | 3    | 0     | 0 | 0                      | 0    | 3     | 0 | 10    | 90            |
| 10:15 AM                        | 0                      | 0    | 0     | 0 | 3                      | 0    | 0     | 0 | 2                      | 6    | 0     | 0 | 0                      | 0    | 0     | 1 | 12    | 92            |
| 10:20 AM                        | 1                      | 0    | 1     | 0 | 0                      | 0    | 1     | 0 | 0                      | 0    | 0     | 0 | 1                      | 0    | 1     | 0 | 5     | 88            |
| 10:25 AM                        | 0                      | 0    | 0     | 0 | 1                      | 0    | 0     | 0 | 0                      | 2    | 0     | 0 | 0                      | 0    | 5     | 0 | 8     | 93            |
| 10:30 AM                        | 0                      | 0    | 0     | 0 | 3                      | 0    | 0     | 0 | 0                      | 1    | 0     | 0 | 0                      | 0    | 0     | 0 | 4     | 89            |
| 10:35 AM                        | 0                      | 0    | 0     | 0 | 3                      | 0    | 0     | 0 | 1                      | 4    | 0     | 0 | 0                      | 0    | 2     | 0 | 10    | 89            |
| 10:40 AM                        | 0                      | 0    | 1     | 0 | 0                      | 0    | 1     | 0 | 0                      | 2    | 0     | 0 | 0                      | 0    | 1     | 0 | 5     | 89            |
| 10:45 AM                        | 0                      | 0    | 0     | 0 | 1                      | 0    | 0     | 0 | 0                      | 1    | 0     | 0 | 0                      | 0    | 1     | 0 | 3     | 84            |
| 10:50 AM                        | 0                      | 0    | 0     | 0 | 2                      | 0    | 0     | 0 | 1                      | 1    | 0     | 0 | 0                      | 14   | 0     | 0 | 18    | 97            |
| 10:55 AM                        | 0                      | 0    | 0     | 0 | 1                      | 0    | 1     | 0 | 0                      | 0    | 1     | 0 | 0                      | 4    | 0     | 0 | 7     | 97            |
| 11:00 AM                        | 1                      | 0    | 0     | 0 | 0                      | 0    | 1     | 0 | 0                      | 3    | 1     | 0 | 0                      | 2    | 1     | 0 | 9     | 99            |
| 11:05 AM                        | 0                      | 0    | 0     | 0 | 1                      | 0    | 1     | 0 | 0                      | 6    | 0     | 0 | 1                      | 2    | 0     | 0 | 11    | 102           |
| 11:10 AM                        | 0                      | 0    | 0     | 0 | 1                      | 0    | 0     | 0 | 0                      | 1    | 0     | 0 | 0                      | 1    | 0     | 0 | 3     | 95            |
| 11:15 AM                        | 0                      | 0    | 0     | 0 | 2                      | 0    | 2     | 0 | 1                      | 2    | 0     | 0 | 0                      | 1    | 0     | 0 | 8     | 91            |
| 11:20 AM                        | 0                      | 0    | 0     | 0 | 1                      | 0    | 1     | 0 | 1                      | 1    | 0     | 0 | 0                      | 6    | 1     | 0 | 11    | 97            |
| 11:25 AM                        | 0                      | 0    | 0     | 0 | 1                      | 0    | 0     | 0 | 0                      | 2    | 0     | 0 | 0                      | 3    | 1     | 0 | 7     | 96            |
| 11:30 AM                        | 0                      | 0    | 0     | 0 | 1                      | 0    | 0     | 0 | 0                      | 0    | 0     | 0 | 0                      | 1    | 0     | 0 | 2     | 94            |
| 11:35 AM                        | 0                      | 0    | 1     | 0 | 4                      | 0    | 0     | 0 | 0                      | 2    | 0     | 0 | 0                      | 4    | 3     | 0 | 14    | 98            |
| 11:40 AM                        | 0                      | 0    | 0     | 0 | 1                      | 0    | 2     | 0 | 1                      | 1    | 1     | 0 | 0                      | 3    | 3     | 0 | 12    | 105           |
| 11:45 AM                        | 0                      | 0    | 0     | 0 | 1                      | 0    | 0     | 0 | 0                      | 5    | 0     | 0 | 0                      | 4    | 0     | 0 | 10    | 112           |
| 11:50 AM                        | 0                      | 0    | 0     | 0 | 0                      | 0    | 1     | 0 | 2                      | 5    | 0     | 0 | 0                      | 7    | 0     | 0 | 15    | 109           |
| 11:55 AM                        | 0                      | 0    | 0     | 0 | 0                      | 0    | 0     | 0 | 0                      | 4    | 0     | 0 | 0                      | 5    | 2     | 0 | 11    | 113           |
| 12:00 PM                        | 0                      | 0    | 0     | 0 | 0                      | 0    | 1     | 0 | 2                      | 1    | 0     | 0 | 0                      | 5    | 0     | 0 | 9     | 113           |
| 12:05 PM                        | 1                      | 0    | 0     | 0 | 0                      | 1    | 0     | 0 | 0                      | 0    | 0     | 0 | 0                      | 4    | 2     | 0 | 8     | 110           |
| 12:10 PM                        | 1                      | 0    | 0     | 0 | 2                      | 0    | 1     | 0 | 0                      | 6    | 0     | 0 | 0                      | 4    | 4     | 0 | 18    | 125           |
| 12:15 PM                        | 0                      | 0    | 0     | 0 | 0                      | 0    | 0     | 0 | 0                      | 2    | 0     | 0 | 0                      | 7    | 0     | 0 | 9     | 126           |
| 12:20 PM                        | 0                      | 0    | 0     | 0 | 0                      | 0    | 0     | 0 | 0                      | 1    | 0     | 0 | 0                      | 2    | 1     | 0 | 4     | 119           |
| 12:25 PM                        | 0                      | 0    | 0     | 0 | 2                      | 0    | 1     | 0 | 1                      | 3    | 0     | 0 | 0                      | 6    | 1     | 0 | 14    | 126           |
| 12:30 PM                        | 0                      | 0    | 0     | 0 | 0                      | 0    | 0     | 0 | 1                      | 0    | 0     | 0 | 0                      | 4    | 1     | 0 | 6     | 130           |
| 12:35 PM                        | 0                      | 0    | 1     | 0 | 1                      | 0    | 0     | 0 | 0                      | 4    | 0     | 0 | 0                      | 2    | 0     | 0 | 8     | 124           |
| 12:40 PM                        | 0                      | 0    | 0     | 0 | 0                      | 0    | 0     | 0 | 0                      | 3    | 0     | 0 | 0                      | 3    | 2     | 0 | 8     | 120           |
| 12:45 PM                        | 0                      | 0    | 0     | 0 | 1                      | 0    | 0     | 0 | 0                      | 3    | 1     | 0 | 0                      | 4    | 3     | 0 | 12    | 122           |
| 12:50 PM                        | 0                      | 0    | 0     | 0 | 3                      | 0    | 1     | 0 | 0                      | 2    | 0     | 0 | 0                      | 1    | 0     | 0 | 7     | 114           |
| 12:55 PM                        | 0                      | 0    | 0     | 0 | 2                      | 0    | 0     | 0 | 0                      | 3    | 0     | 0 | 0                      | 4    | 3     | 0 | 12    | 115           |
| 1:00 PM                         | 0                      | 0    | 0     | 0 | 1                      | 0    | 0     | 0 | 0                      | 2    | 0     | 0 | 0                      | 4    | 0     | 0 | 7     | 113           |
| 1:05 PM                         | 0                      | 0    | 0     | 0 | 2                      | 0    | 2     | 0 | 1                      | 2    | 0     | 0 | 0                      | 6    | 0     | 0 | 13    | 118           |
| 1:10 PM                         | 0                      | 0    | 0     | 0 | 0                      | 0    | 1     | 0 | 1                      | 3    | 1     | 0 | 0                      | 4    | 3     | 0 | 13    | 113           |
| 1:15 PM                         | 0                      | 0    | 0     | 0 | 0                      | 0    | 0     | 0 | 1                      | 3    | 0     | 0 | 0                      | 3    | 0     | 0 | 7     | 111           |
| 1:20 PM                         | 0                      | 0    | 0     | 0 | 0                      | 0    | 1     | 0 | 1                      | 5    | 0     | 0 | 0                      | 2    | 2     | 0 | 11    | 118           |
| 1:25 PM                         | 0                      | 0    | 1     | 0 | 1                      | 0    | 1     | 0 | 0                      | 1    | 0     | 0 | 1                      | 1    | 0     | 0 | 6     | 110           |
| 1:30 PM                         | 0                      | 0    | 0     | 0 | 0                      | 0    | 1     | 0 | 1                      | 9    | 0     | 0 | 0                      | 3    | 1     | 0 | 15    | 119           |
| 1:35 PM                         | 0                      | 0    | 0     | 0 | 3                      | 0    | 0     | 0 | 0                      | 9    | 0     | 0 | 0                      | 3    | 5     | 0 | 20    | 131           |
| 1:40 PM                         | 1                      | 0    | 0     | 0 | 1                      | 0    | 1     | 0 | 0                      | 3    | 0     | 0 | 1                      | 8    | 0     | 0 | 15    | 138           |
| 1:45 PM                         | 0                      | 0    | 0     | 0 | 0                      | 0    | 0     | 0 | 0                      | 1    | 0     | 0 | 0                      | 15   | 5     | 0 | 21    | 147           |
| 1:50 PM                         | 1                      | 0    | 0     | 0 | 4                      | 0    | 2     | 0 | 0                      | 5    | 0     | 0 | 0                      | 3    | 1     | 0 | 16    | 156           |
| 1:55 PM                         | 1                      | 0    | 0     | 0 | 3                      | 0    | 0     | 0 | 0                      | 5    | 1     | 0 | 0                      | 4    | 1     | 0 | 15    | 159           |
| 2:00 PM                         | 0                      | 0    | 0     | 0 | 3                      | 0    | 2     | 0 | 2                      | 6    | 0     | 0 | 0                      | 5    | 2     | 0 | 20    | 172           |
| 2:05 PM                         | 0                      | 0    | 0     | 0 | 1                      | 0    | 0     | 0 | 0                      | 6    | 0     | 0 | 0                      | 4    | 2     | 0 | 13    | 172           |
| 2:10 PM                         | 0                      | 0    | 0     | 0 | 2                      | 0    | 0     | 0 | 0                      | 3    | 0     | 0 | 0                      | 3    | 2     | 0 | 10    | 169           |
| 2:15 PM                         | 0                      | 0    | 1     | 0 | 2                      | 0    | 1     | 0 | 0                      | 6    | 0     | 0 | 0                      | 6    | 2     | 0 | 18    | 180           |
| 2:20 PM                         | 0                      | 0    | 0     | 0 | 4                      | 0    | 1     | 0 | 1                      | 9    | 1     | 0 | 0                      | 9    | 1     | 0 | 26    | 195           |
| 2:25 PM                         | 0                      | 0    | 0     | 0 | 1                      | 0    | 0     | 0 | 1                      | 9    | 0     | 0 | 0                      | 4    | 0     | 0 | 15    | 204           |
| 2:30 PM                         | 0                      | 0    | 0     | 0 | 2                      | 0    | 0     | 0 | 1                      | 11   | 0     | 0 | 0                      | 9    | 1     | 0 | 24    | 213           |
| 2:35 PM                         | 0                      | 0    | 0     | 0 | 2                      | 0    | 1     | 0 | 0                      | 11   | 0     | 0 | 0                      | 17   | 4     | 0 | 35    | 228           |
| 2:40 PM                         | 0                      | 0    | 0     | 0 | 0                      | 0    | 0     | 0 | 0                      | 4    | 0     | 0 | 0                      | 29   | 1     | 0 | 34    | 247           |
| 2:45 PM                         | 0                      | 0    | 0     | 0 | 1                      | 0    | 0     | 0 | 1                      | 1    | 1     | 0 | 0                      | 8    | 1     | 0 | 13    | 239           |
| 2:50 PM                         | 1                      | 0    | 0     | 0 | 1                      | 0    | 1     | 0 | 0                      | 5    | 0     | 0 | 0                      | 7    | 1     | 0 | 16    | 239           |
| 2:55 PM                         | 1                      | 0    | 0     | 0 | 3                      | 0    | 1     | 0 | 2                      | 1    | 0     | 0 | 1                      | 4    | 0     | 0 | 13    | 237           |
| 3:00 PM                         | 0                      | 0    | 0     | 0 | 0                      | 0    | 1     | 0 | 1                      | 3    | 0     | 0 | 0                      | 4    | 2     | 0 | 11    | 228           |
| 3:05 PM                         | 0                      | 0    | 0     | 0 | 1                      | 0    | 1     | 0 | 0                      | 3    | 0     | 0 | 0                      | 7    | 1     | 0 | 13    | 228           |
| 3:10 PM                         | 0                      | 0    | 0     | 0 | 1                      | 0    | 1     | 0 | 2                      | 4    | 2     | 0 | 0                      | 5    | 0     | 0 | 15    | 233           |
| 3:15 PM                         | 0                      | 0    | 0     | 0 | 5                      | 0    | 0     | 0 | 1                      | 4    | 0     | 0 | 0                      | 5    | 4     | 0 | 19    | 234           |
| 3:20 PM                         | 0                      | 0    | 1     | 0 | 0                      | 0    | 1     | 0 | 3                      | 1    | 0     | 0 | 0                      | 10   | 0     | 0 | 16    | 224           |
| 3:25 PM                         | 0                      | 0    | 0     | 0 | 3                      | 0    | 0     | 0 | 0                      | 3    | 0     | 0 | 0                      | 5    | 4     | 0 | 15    | 224           |
| 3:30 PM                         | 0                      | 0    | 0     | 0 | 1                      | 0    | 0     | 0 | 0                      | 4    | 0     | 0 | 0                      | 10   | 2     | 0 | 17    | 217           |
| 3:35 PM                         | 1                      | 0    | 0     | 0 | 2                      | 0    | 1     | 0 | 1                      | 5    | 0     | 0 | 1                      | 7    | 1     | 0 | 19    | 201           |
| 3:40 PM                         | 0                      | 0    | 1     | 0 | 2                      | 0    | 0     | 0 | 1                      | 2    | 0     | 0 | 0                      | 9    | 1     | 0 | 16    | 183           |
| 3:45 PM                         | 0                      | 0    | 0     | 0 | 3                      | 0    | 1     | 0 | 0                      | 3    | 0     | 0 | 0                      | 5    | 0     | 0 | 12    | 182           |
| 3:50 PM                         | 0                      | 0    | 0     | 0 | 3                      | 0    | 0     | 0 | 0                      | 5    | 0     | 0 | 0                      | 10   | 1     | 0 | 19    | 185           |
| 3:55 PM                         | 1                      | 0    | 0     | 0 | 1                      | 0    | 1     | 0 | 0                      | 0    | 0     | 0 | 0                      | 11   | 0     | 0 | 14    | 186           |
| 4:00 PM                         | 0                      | 0    | 0     | 0 | 0                      | 0    | 2     | 0 | 0                      | 2    | 0     | 0 | 1                      | 20   | 1     | 0 | 26    | 201           |
| 4:05 PM                         | 0                      | 0    | 0     | 0 | 0                      | 0    | 1     | 0 | 0                      | 3    | 0     | 0 | 0                      | 4    | 6     | 0 | 14    | 202           |
| 4:10 PM                         | 0                      | 0    | 0     | 0 | 0                      | 0    | 0     | 0 | 0                      | 4    | 0     | 0 | 1                      | 10   | 2     | 0 | 17    | 204           |
| 4:15 PM                         | 0                      | 0    | 0     | 0 | 4                      | 0    | 1     | 0 | 0                      | 5    | 1     | 0 | 0                      | 8    | 3     | 0 | 22    | 207           |
| 4:20 PM                         | 0                      | 0    | 0     | 0 | 1                      | 0    | 1     | 0 | 1                      | 3    | 1     | 0 | 1                      | 7    | 1     | 0 | 16    | 207           |
| 4:25 PM                         | 1                      | 0    | 0     | 0 | 3                      | 0    | 0     | 0 | 2                      | 2    | 0     | 0 | 2                      | 6    | 2     | 0 | 18    | 210           |
| 4:30 PM                         | 1                      | 0    | 0     | 0 | 2                      | 0    | 3     | 0 | 1                      | 1    | 0     | 0 | 0                      | 6    | 2     | 0 | 16    | 209           |

**Attachment B**

| 5-Min Count Period Beginning At | Colony Dr (Northbound) |      |       |   | Colony Dr (Southbound) |      |       |   | La Loma Dr (Eastbound) |      |       |   | La Loma Dr (Westbound) |      |       |   | Total | Hourly Totals |
|---------------------------------|------------------------|------|-------|---|------------------------|------|-------|---|------------------------|------|-------|---|------------------------|------|-------|---|-------|---------------|
|                                 | Left                   | Thru | Right | U | Left                   | Thru | Right | U | Left                   | Thru | Right | U | Left                   | Thru | Right | U |       |               |
| 4:35 PM                         | 1                      | 0    | 1     | 0 | 0                      | 0    | 1     | 0 | 0                      | 3    | 0     | 0 | 0                      | 12   | 1     | 0 | 19    | 209           |
| 4:40 PM                         | 0                      | 0    | 0     | 0 | 1                      | 0    | 1     | 0 | 1                      | 2    | 0     | 0 | 1                      | 10   | 2     | 0 | 18    | 211           |
| 4:45 PM                         | 0                      | 0    | 0     | 0 | 0                      | 0    | 0     | 0 | 1                      | 4    | 0     | 0 | 0                      | 11   | 2     | 0 | 18    | 217           |
| 4:50 PM                         | 0                      | 0    | 0     | 0 | 3                      | 0    | 0     | 0 | 0                      | 2    | 1     | 0 | 0                      | 13   | 5     | 0 | 24    | 222           |
| 4:55 PM                         | 0                      | 0    | 0     | 0 | 0                      | 0    | 1     | 0 | 1                      | 2    | 1     | 0 | 0                      | 12   | 4     | 0 | 21    | 229           |
| 5:00 PM                         | 0                      | 0    | 0     | 0 | 1                      | 0    | 0     | 0 | 0                      | 4    | 0     | 0 | 1                      | 13   | 1     | 0 | 20    | 223           |
| 5:05 PM                         | 0                      | 0    | 0     | 0 | 3                      | 0    | 0     | 0 | 0                      | 1    | 1     | 0 | 1                      | 15   | 4     | 0 | 25    | 234           |
| 5:10 PM                         | 0                      | 0    | 0     | 0 | 2                      | 0    | 0     | 0 | 0                      | 2    | 4     | 0 | 0                      | 11   | 3     | 0 | 22    | 239           |
| 5:15 PM                         | 0                      | 0    | 0     | 0 | 2                      | 0    | 1     | 0 | 0                      | 3    | 1     | 0 | 0                      | 13   | 1     | 0 | 21    | 238           |
| 5:20 PM                         | 0                      | 0    | 1     | 0 | 2                      | 0    | 1     | 0 | 0                      | 4    | 0     | 0 | 1                      | 8    | 1     | 0 | 18    | 240           |
| 5:25 PM                         | 0                      | 0    | 0     | 0 | 5                      | 0    | 0     | 0 | 0                      | 0    | 1     | 0 | 1                      | 12   | 4     | 0 | 23    | 245           |
| 5:30 PM                         | 0                      | 0    | 0     | 0 | 3                      | 0    | 0     | 0 | 1                      | 4    | 0     | 0 | 0                      | 13   | 1     | 0 | 22    | 251           |
| 5:35 PM                         | 0                      | 0    | 0     | 0 | 5                      | 0    | 0     | 0 | 0                      | 3    | 0     | 0 | 0                      | 8    | 1     | 0 | 17    | 249           |
| 5:40 PM                         | 0                      | 0    | 0     | 0 | 0                      | 0    | 0     | 0 | 1                      | 2    | 1     | 0 | 1                      | 6    | 3     | 0 | 14    | 245           |
| 5:45 PM                         | 0                      | 0    | 0     | 0 | 2                      | 0    | 1     | 0 | 1                      | 3    | 0     | 0 | 0                      | 13   | 2     | 0 | 22    | 249           |
| 5:50 PM                         | 0                      | 0    | 0     | 0 | 0                      | 0    | 0     | 0 | 1                      | 4    | 0     | 0 | 0                      | 10   | 2     | 0 | 17    | 242           |
| 5:55 PM                         | 0                      | 1    | 0     | 0 | 0                      | 0    | 0     | 0 | 0                      | 0    | 1     | 0 | 0                      | 6    | 3     | 0 | 11    | 232           |
| 6:00 PM                         | 0                      | 0    | 0     | 0 | 0                      | 0    | 1     | 0 | 0                      | 1    | 0     | 0 | 0                      | 11   | 0     | 0 | 13    | 225           |
| 6:05 PM                         | 0                      | 0    | 1     | 0 | 1                      | 0    | 1     | 0 | 0                      | 1    | 0     | 0 | 0                      | 2    | 2     | 0 | 8     | 208           |
| 6:10 PM                         | 0                      | 0    | 0     | 0 | 1                      | 0    | 0     | 0 | 0                      | 3    | 0     | 0 | 0                      | 7    | 4     | 0 | 15    | 201           |
| 6:15 PM                         | 0                      | 0    | 0     | 0 | 0                      | 0    | 0     | 0 | 0                      | 1    | 0     | 0 | 0                      | 10   | 6     | 0 | 17    | 197           |
| 6:20 PM                         | 0                      | 0    | 0     | 0 | 2                      | 0    | 1     | 0 | 0                      | 2    | 1     | 0 | 0                      | 5    | 1     | 0 | 12    | 191           |
| 6:25 PM                         | 0                      | 0    | 0     | 0 | 0                      | 0    | 1     | 0 | 0                      | 1    | 0     | 0 | 0                      | 7    | 1     | 0 | 10    | 178           |
| 6:30 PM                         | 0                      | 0    | 0     | 0 | 3                      | 0    | 0     | 0 | 1                      | 4    | 0     | 0 | 0                      | 7    | 3     | 0 | 18    | 174           |
| 6:35 PM                         | 1                      | 0    | 0     | 0 | 0                      | 0    | 0     | 0 | 0                      | 3    | 0     | 0 | 0                      | 6    | 3     | 0 | 13    | 170           |
| 6:40 PM                         | 0                      | 0    | 0     | 0 | 0                      | 0    | 0     | 0 | 0                      | 1    | 0     | 0 | 0                      | 6    | 2     | 0 | 9     | 165           |
| 6:45 PM                         | 0                      | 0    | 0     | 0 | 1                      | 0    | 0     | 0 | 0                      | 3    | 1     | 0 | 0                      | 7    | 2     | 0 | 14    | 157           |
| 6:50 PM                         | 0                      | 0    | 0     | 0 | 0                      | 0    | 0     | 0 | 2                      | 5    | 0     | 0 | 0                      | 2    | 1     | 0 | 10    | 150           |
| 6:55 PM                         | 0                      | 0    | 1     | 0 | 2                      | 0    | 0     | 0 | 0                      | 1    | 0     | 0 | 0                      | 7    | 1     | 0 | 12    | 151           |
| 7:00 PM                         | 0                      | 0    | 1     | 0 | 1                      | 1    | 0     | 0 | 1                      | 2    | 1     | 0 | 1                      | 3    | 0     | 0 | 11    | 149           |
| 7:05 PM                         | 0                      | 0    | 0     | 0 | 2                      | 0    | 0     | 0 | 0                      | 5    | 0     | 0 | 1                      | 6    | 0     | 0 | 14    | 155           |
| 7:10 PM                         | 0                      | 0    | 1     | 0 | 0                      | 0    | 0     | 0 | 2                      | 1    | 0     | 0 | 0                      | 6    | 2     | 0 | 12    | 152           |
| 7:15 PM                         | 0                      | 0    | 0     | 0 | 0                      | 0    | 0     | 0 | 1                      | 1    | 0     | 0 | 0                      | 4    | 1     | 0 | 7     | 142           |
| 7:20 PM                         | 0                      | 0    | 0     | 0 | 0                      | 0    | 0     | 0 | 0                      | 1    | 0     | 0 | 0                      | 7    | 1     | 0 | 9     | 139           |
| 7:25 PM                         | 0                      | 0    | 0     | 0 | 2                      | 0    | 0     | 0 | 1                      | 2    | 0     | 0 | 0                      | 2    | 1     | 0 | 8     | 137           |
| 7:30 PM                         | 0                      | 0    | 0     | 0 | 0                      | 0    | 2     | 0 | 0                      | 2    | 0     | 0 | 0                      | 3    | 1     | 0 | 8     | 127           |
| 7:35 PM                         | 0                      | 0    | 0     | 0 | 1                      | 0    | 0     | 0 | 0                      | 0    | 0     | 0 | 0                      | 2    | 1     | 0 | 4     | 118           |
| 7:40 PM                         | 0                      | 0    | 0     | 0 | 0                      | 0    | 0     | 0 | 0                      | 1    | 0     | 0 | 0                      | 2    | 1     | 0 | 4     | 113           |
| 7:45 PM                         | 0                      | 0    | 0     | 0 | 0                      | 0    | 0     | 0 | 0                      | 2    | 0     | 0 | 0                      | 4    | 0     | 0 | 6     | 105           |
| 7:50 PM                         | 0                      | 0    | 0     | 0 | 0                      | 0    | 0     | 0 | 0                      | 1    | 0     | 0 | 0                      | 2    | 2     | 0 | 5     | 100           |
| 7:55 PM                         | 0                      | 0    | 0     | 0 | 1                      | 0    | 0     | 0 | 0                      | 1    | 0     | 0 | 1                      | 1    | 0     | 0 | 4     | 92            |
| 8:00 PM                         | 0                      | 0    | 0     | 0 | 0                      | 0    | 0     | 0 | 0                      | 0    | 0     | 0 | 0                      | 2    | 1     | 0 | 3     | 84            |
| 8:05 PM                         | 0                      | 0    | 0     | 0 | 1                      | 0    | 0     | 0 | 0                      | 1    | 0     | 0 | 0                      | 0    | 1     | 0 | 3     | 73            |
| 8:10 PM                         | 0                      | 0    | 0     | 0 | 0                      | 0    | 1     | 0 | 0                      | 0    | 0     | 0 | 0                      | 4    | 0     | 0 | 5     | 66            |
| 8:15 PM                         | 0                      | 0    | 0     | 0 | 0                      | 0    | 0     | 0 | 1                      | 1    | 0     | 0 | 0                      | 3    | 2     | 0 | 7     | 66            |
| 8:20 PM                         | 0                      | 0    | 1     | 0 | 0                      | 0    | 0     | 0 | 0                      | 1    | 0     | 0 | 0                      | 5    | 0     | 0 | 7     | 64            |
| 8:25 PM                         | 0                      | 0    | 0     | 0 | 2                      | 0    | 0     | 0 | 0                      | 1    | 0     | 0 | 0                      | 0    | 3     | 0 | 6     | 62            |
| 8:30 PM                         | 0                      | 0    | 0     | 0 | 1                      | 0    | 0     | 0 | 1                      | 2    | 0     | 0 | 0                      | 0    | 0     | 0 | 4     | 58            |
| 8:35 PM                         | 0                      | 0    | 0     | 0 | 0                      | 0    | 0     | 0 | 0                      | 1    | 0     | 0 | 0                      | 1    | 1     | 0 | 3     | 57            |
| 8:40 PM                         | 0                      | 0    | 0     | 0 | 0                      | 0    | 0     | 0 | 1                      | 2    | 0     | 0 | 0                      | 2    | 1     | 0 | 6     | 59            |
| 8:45 PM                         | 1                      | 0    | 0     | 0 | 0                      | 0    | 0     | 0 | 0                      | 3    | 0     | 0 | 1                      | 2    | 1     | 0 | 8     | 61            |
| 8:50 PM                         | 0                      | 0    | 0     | 0 | 0                      | 0    | 0     | 0 | 0                      | 2    | 0     | 0 | 0                      | 2    | 0     | 0 | 4     | 60            |
| 8:55 PM                         | 0                      | 0    | 0     | 0 | 0                      | 0    | 0     | 0 | 1                      | 1    | 2     | 0 | 0                      | 3    | 1     | 0 | 8     | 64            |
| 9:00 PM                         | 0                      | 0    | 0     | 0 | 0                      | 0    | 0     | 0 | 0                      | 1    | 0     | 0 | 0                      | 4    | 0     | 0 | 5     | 66            |
| 9:05 PM                         | 0                      | 0    | 0     | 0 | 0                      | 0    | 0     | 0 | 0                      | 0    | 0     | 0 | 0                      | 4    | 1     | 0 | 5     | 68            |
| 9:10 PM                         | 1                      | 0    | 0     | 0 | 1                      | 0    | 0     | 0 | 0                      | 0    | 0     | 0 | 0                      | 2    | 0     | 0 | 4     | 67            |
| 9:15 PM                         | 0                      | 0    | 0     | 0 | 0                      | 0    | 0     | 0 | 0                      | 3    | 0     | 0 | 0                      | 1    | 1     | 0 | 5     | 65            |
| 9:20 PM                         | 0                      | 0    | 0     | 0 | 0                      | 0    | 0     | 0 | 1                      | 0    | 0     | 0 | 0                      | 3    | 4     | 0 | 8     | 66            |
| 9:25 PM                         | 0                      | 0    | 0     | 0 | 0                      | 0    | 0     | 0 | 0                      | 1    | 0     | 0 | 0                      | 3    | 2     | 0 | 6     | 66            |
| 9:30 PM                         | 0                      | 0    | 0     | 0 | 0                      | 0    | 0     | 0 | 1                      | 0    | 0     | 0 | 0                      | 1    | 1     | 0 | 3     | 65            |
| 9:35 PM                         | 0                      | 0    | 0     | 0 | 0                      | 0    | 0     | 0 | 0                      | 1    | 0     | 0 | 1                      | 1    | 0     | 0 | 3     | 65            |
| 9:40 PM                         | 0                      | 0    | 0     | 0 | 0                      | 0    | 0     | 0 | 0                      | 0    | 0     | 0 | 0                      | 3    | 2     | 0 | 5     | 64            |
| 9:45 PM                         | 0                      | 0    | 0     | 0 | 0                      | 0    | 0     | 0 | 0                      | 0    | 0     | 0 | 0                      | 1    | 0     | 0 | 1     | 57            |
| 9:50 PM                         | 0                      | 0    | 0     | 0 | 0                      | 0    | 0     | 0 | 2                      | 0    | 0     | 0 | 0                      | 1    | 1     | 0 | 4     | 57            |
| 9:55 PM                         | 0                      | 0    | 0     | 0 | 0                      | 0    | 0     | 0 | 1                      | 0    | 0     | 0 | 0                      | 1    | 0     | 0 | 2     | 51            |
| Peak 15-Min Flowrates           | Northbound             |      |       |   | Southbound             |      |       |   | Eastbound              |      |       |   | Westbound              |      |       |   | Total |               |
|                                 | Left                   | Thru | Right | U | Left                   | Thru | Right | U | Left                   | Thru | Right | U | Left                   | Thru | Right | U |       |               |
| All Vehicles                    | 4                      | 0    | 0     | 0 | 68                     | 0    | 28    | 0 | 12                     | 232  | 8     | 0 | 0                      | 200  | 24    | 0 | 576   |               |
| Heavy Trucks                    | 0                      | 0    | 0     | 0 | 0                      | 0    | 0     | 0 | 0                      | 0    | 0     | 0 | 0                      | 4    | 4     | 0 | 8     |               |
| Buses                           |                        |      |       |   |                        |      |       |   |                        |      |       |   |                        |      |       |   |       |               |
| Pedestrians                     |                        | 4    |       |   |                        | 0    |       |   |                        | 0    |       |   |                        | 0    |       |   | 4     |               |
| Bicycles                        | 0                      | 0    | 0     |   | 0                      | 0    | 0     |   | 0                      | 0    | 0     |   | 0                      | 0    | 0     |   | 0     |               |
| Scoters                         |                        |      |       |   |                        |      |       |   |                        |      |       |   |                        |      |       |   |       |               |
| <i>Comments:</i>                |                        |      |       |   |                        |      |       |   |                        |      |       |   |                        |      |       |   |       |               |

Report generated on 4/25/2025 4:02 PM

SOURCE: Quality Counts, LLC (<http://www.qualitycounts.net>) 1-877-580-2212

LOCATION: Brier Ln -- Highcliff Dr  
 CITY/STATE: North Tustin, CA

QC JOB #: 16966433  
 DATE: Thu, Apr 10 2025

Peak-Hour: 2:50 PM -- 3:50 PM  
 Peak 15-Min: 3:30 PM -- 3:45 PM

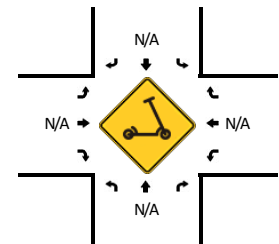
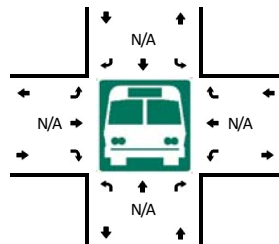
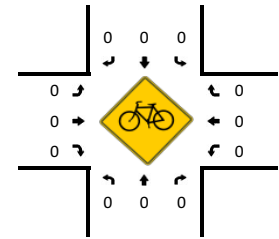
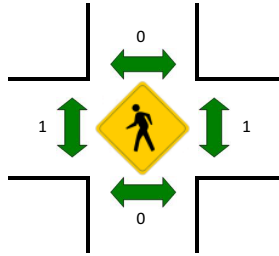
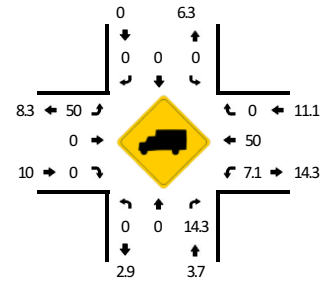
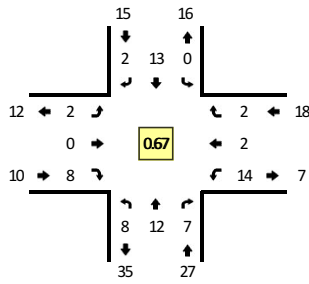

| 5-Min Count Period Beginning At | Brier Ln (Northbound) |      |       |   | Brier Ln (Southbound) |      |       |   | Highcliff Dr (Eastbound) |      |       |   | Highcliff Dr (Westbound) |      |       |   | Total | Hourly Totals |
|---------------------------------|-----------------------|------|-------|---|-----------------------|------|-------|---|--------------------------|------|-------|---|--------------------------|------|-------|---|-------|---------------|
|                                 | Left                  | Thru | Right | U | Left                  | Thru | Right | U | Left                     | Thru | Right | U | Left                     | Thru | Right | U |       |               |
| 6:00 AM                         | 0                     | 0    | 0     | 0 | 0                     | 0    | 0     | 0 | 0                        | 0    | 0     | 0 | 0                        | 0    | 0     | 0 | 0     | 0             |
| 6:05 AM                         | 0                     | 0    | 1     | 0 | 0                     | 0    | 0     | 0 | 0                        | 0    | 0     | 1 | 0                        | 0    | 0     | 0 | 0     | 2             |
| 6:10 AM                         | 0                     | 0    | 0     | 0 | 0                     | 0    | 0     | 0 | 0                        | 0    | 0     | 0 | 0                        | 0    | 0     | 0 | 0     | 0             |
| 6:15 AM                         | 0                     | 0    | 0     | 0 | 0                     | 0    | 0     | 0 | 0                        | 0    | 0     | 0 | 0                        | 0    | 0     | 0 | 0     | 0             |
| 6:20 AM                         | 0                     | 0    | 1     | 0 | 0                     | 0    | 1     | 0 | 0                        | 0    | 1     | 0 | 0                        | 0    | 0     | 0 | 0     | 3             |
| 6:25 AM                         | 1                     | 0    | 0     | 0 | 0                     | 0    | 0     | 0 | 0                        | 0    | 0     | 1 | 0                        | 0    | 0     | 0 | 0     | 3             |
| 6:30 AM                         | 0                     | 0    | 0     | 0 | 0                     | 1    | 0     | 0 | 0                        | 0    | 0     | 0 | 0                        | 1    | 0     | 0 | 0     | 2             |
| 6:35 AM                         | 0                     | 0    | 0     | 0 | 0                     | 0    | 0     | 0 | 0                        | 0    | 0     | 1 | 0                        | 0    | 0     | 0 | 0     | 1             |
| 6:40 AM                         | 0                     | 0    | 0     | 0 | 0                     | 0    | 0     | 0 | 0                        | 0    | 0     | 1 | 0                        | 0    | 0     | 0 | 0     | 1             |
| 6:45 AM                         | 0                     | 1    | 0     | 0 | 0                     | 1    | 0     | 0 | 0                        | 0    | 0     | 0 | 0                        | 0    | 0     | 0 | 0     | 2             |
| 6:50 AM                         | 0                     | 0    | 1     | 0 | 0                     | 0    | 0     | 0 | 0                        | 0    | 0     | 0 | 0                        | 0    | 0     | 0 | 0     | 1             |
| 6:55 AM                         | 2                     | 1    | 0     | 0 | 0                     | 0    | 0     | 0 | 0                        | 0    | 0     | 0 | 0                        | 0    | 0     | 0 | 0     | 3             |
| 7:00 AM                         | 0                     | 0    | 1     | 0 | 0                     | 0    | 0     | 0 | 0                        | 0    | 0     | 1 | 0                        | 0    | 0     | 0 | 0     | 2             |
| 7:05 AM                         | 0                     | 0    | 2     | 0 | 0                     | 0    | 0     | 0 | 0                        | 0    | 0     | 0 | 0                        | 1    | 0     | 0 | 0     | 3             |
| 7:10 AM                         | 0                     | 0    | 0     | 0 | 0                     | 2    | 0     | 0 | 0                        | 0    | 0     | 2 | 0                        | 0    | 0     | 0 | 0     | 4             |
| 7:15 AM                         | 0                     | 0    | 1     | 0 | 0                     | 0    | 0     | 0 | 0                        | 0    | 0     | 0 | 0                        | 2    | 0     | 0 | 0     | 3             |
| 7:20 AM                         | 0                     | 0    | 1     | 0 | 0                     | 0    | 0     | 0 | 0                        | 0    | 0     | 0 | 0                        | 1    | 0     | 0 | 0     | 2             |
| 7:25 AM                         | 0                     | 0    | 0     | 0 | 0                     | 1    | 0     | 0 | 0                        | 0    | 0     | 0 | 0                        | 0    | 0     | 0 | 0     | 1             |
| 7:30 AM                         | 0                     | 0    | 0     | 0 | 0                     | 3    | 0     | 0 | 0                        | 0    | 0     | 0 | 0                        | 0    | 0     | 0 | 0     | 3             |
| 7:35 AM                         | 0                     | 2    | 0     | 0 | 0                     | 1    | 0     | 0 | 0                        | 0    | 0     | 0 | 0                        | 0    | 0     | 0 | 0     | 3             |
| 7:40 AM                         | 0                     | 3    | 1     | 0 | 0                     | 3    | 0     | 0 | 0                        | 0    | 0     | 1 | 0                        | 0    | 0     | 0 | 0     | 8             |
| 7:45 AM                         | 1                     | 1    | 0     | 0 | 0                     | 3    | 0     | 0 | 0                        | 0    | 0     | 1 | 0                        | 1    | 0     | 0 | 0     | 7             |
| 7:50 AM                         | 2                     | 1    | 2     | 0 | 0                     | 0    | 0     | 0 | 0                        | 0    | 0     | 0 | 0                        | 0    | 0     | 0 | 0     | 5             |
| 7:55 AM                         | 0                     | 0    | 0     | 0 | 0                     | 2    | 0     | 0 | 0                        | 0    | 0     | 0 | 0                        | 2    | 0     | 0 | 0     | 4             |
| 8:00 AM                         | 1                     | 0    | 1     | 0 | 1                     | 2    | 0     | 0 | 0                        | 0    | 0     | 0 | 0                        | 2    | 0     | 0 | 0     | 7             |
| 8:05 AM                         | 0                     | 0    | 0     | 0 | 0                     | 0    | 0     | 0 | 0                        | 0    | 0     | 2 | 0                        | 1    | 0     | 0 | 0     | 3             |
| 8:10 AM                         | 0                     | 1    | 1     | 0 | 0                     | 2    | 0     | 0 | 0                        | 0    | 0     | 1 | 0                        | 0    | 0     | 0 | 0     | 5             |
| 8:15 AM                         | 1                     | 1    | 0     | 0 | 0                     | 0    | 0     | 0 | 0                        | 0    | 0     | 0 | 0                        | 0    | 0     | 0 | 0     | 2             |
| 8:20 AM                         | 0                     | 0    | 0     | 0 | 0                     | 0    | 0     | 0 | 0                        | 0    | 0     | 0 | 0                        | 1    | 0     | 0 | 0     | 1             |
| 8:25 AM                         | 1                     | 2    | 0     | 0 | 0                     | 0    | 0     | 0 | 0                        | 0    | 0     | 0 | 0                        | 0    | 0     | 0 | 0     | 3             |
| 8:30 AM                         | 0                     | 0    | 0     | 0 | 0                     | 0    | 0     | 0 | 0                        | 0    | 0     | 0 | 0                        | 0    | 0     | 0 | 0     | 0             |
| 8:35 AM                         | 2                     | 1    | 0     | 0 | 0                     | 1    | 0     | 0 | 0                        | 0    | 0     | 0 | 0                        | 0    | 0     | 0 | 0     | 4             |
| 8:40 AM                         | 0                     | 0    | 0     | 0 | 0                     | 2    | 0     | 0 | 0                        | 0    | 0     | 1 | 0                        | 0    | 0     | 0 | 0     | 3             |
| 8:45 AM                         | 0                     | 0    | 1     | 0 | 0                     | 1    | 0     | 0 | 0                        | 0    | 0     | 0 | 0                        | 0    | 0     | 0 | 0     | 2             |
| 8:50 AM                         | 1                     | 1    | 0     | 0 | 0                     | 2    | 0     | 0 | 0                        | 0    | 0     | 0 | 0                        | 1    | 0     | 0 | 0     | 5             |
| 8:55 AM                         | 0                     | 2    | 1     | 0 | 0                     | 0    | 0     | 0 | 0                        | 0    | 0     | 0 | 0                        | 1    | 0     | 0 | 0     | 4             |
| 9:00 AM                         | 0                     | 1    | 0     | 0 | 0                     | 0    | 0     | 0 | 0                        | 0    | 0     | 0 | 0                        | 1    | 0     | 0 | 0     | 2             |
| 9:05 AM                         | 2                     | 0    | 0     | 0 | 0                     | 1    | 0     | 0 | 0                        | 0    | 0     | 2 | 0                        | 0    | 0     | 0 | 0     | 5             |

### Attachment B

| 5-Min Count Period Beginning At | Brier Ln (Northbound) |      |       |   | Brier Ln (Southbound) |      |       |   | Highcliff Dr (Eastbound) |      |       |   | Highcliff Dr (Westbound) |      |       |   | Total | Hourly Totals |    |
|---------------------------------|-----------------------|------|-------|---|-----------------------|------|-------|---|--------------------------|------|-------|---|--------------------------|------|-------|---|-------|---------------|----|
|                                 | Left                  | Thru | Right | U | Left                  | Thru | Right | U | Left                     | Thru | Right | U | Left                     | Thru | Right | U |       |               |    |
| 9:10 AM                         | 1                     | 1    | 0     | 0 | 0                     | 2    | 0     | 0 | 0                        | 0    | 0     | 0 | 0                        | 1    | 0     | 0 | 0     | 5             | 36 |
| 9:15 AM                         | 0                     | 2    | 0     | 0 | 0                     | 1    | 0     | 0 | 0                        | 0    | 0     | 0 | 0                        | 0    | 0     | 0 | 0     | 3             | 37 |
| 9:20 AM                         | 1                     | 0    | 0     | 0 | 0                     | 1    | 0     | 0 | 0                        | 0    | 0     | 0 | 0                        | 1    | 0     | 0 | 0     | 3             | 39 |
| 9:25 AM                         | 1                     | 0    | 0     | 0 | 0                     | 3    | 0     | 0 | 0                        | 0    | 0     | 1 | 0                        | 0    | 0     | 0 | 0     | 5             | 41 |
| 9:30 AM                         | 0                     | 0    | 1     | 0 | 0                     | 1    | 0     | 0 | 0                        | 0    | 0     | 1 | 0                        | 0    | 0     | 0 | 0     | 3             | 44 |
| 9:35 AM                         | 0                     | 1    | 1     | 0 | 0                     | 1    | 0     | 0 | 0                        | 0    | 0     | 1 | 0                        | 0    | 0     | 0 | 0     | 4             | 44 |
| 9:40 AM                         | 0                     | 1    | 0     | 0 | 0                     | 1    | 0     | 0 | 0                        | 0    | 0     | 0 | 0                        | 0    | 0     | 0 | 0     | 2             | 43 |
| 9:45 AM                         | 0                     | 0    | 0     | 0 | 0                     | 1    | 0     | 0 | 0                        | 0    | 0     | 0 | 0                        | 0    | 0     | 0 | 0     | 1             | 42 |
| 9:50 AM                         | 1                     | 0    | 2     | 0 | 0                     | 2    | 0     | 0 | 0                        | 0    | 0     | 0 | 0                        | 0    | 0     | 0 | 0     | 5             | 42 |
| 9:55 AM                         | 0                     | 0    | 0     | 0 | 0                     | 0    | 0     | 0 | 0                        | 0    | 0     | 0 | 0                        | 0    | 0     | 0 | 0     | 0             | 38 |
| 10:00 AM                        | 2                     | 0    | 0     | 0 | 0                     | 0    | 0     | 0 | 0                        | 0    | 0     | 0 | 0                        | 1    | 0     | 0 | 0     | 3             | 39 |
| 10:05 AM                        | 1                     | 0    | 0     | 0 | 1                     | 0    | 0     | 0 | 0                        | 0    | 0     | 0 | 0                        | 1    | 0     | 0 | 0     | 3             | 37 |
| 10:10 AM                        | 0                     | 0    | 0     | 0 | 0                     | 1    | 0     | 0 | 0                        | 0    | 0     | 0 | 0                        | 2    | 0     | 0 | 0     | 3             | 35 |
| 10:15 AM                        | 0                     | 0    | 0     | 0 | 0                     | 1    | 0     | 0 | 0                        | 0    | 0     | 0 | 0                        | 1    | 0     | 0 | 0     | 2             | 34 |
| 10:20 AM                        | 1                     | 0    | 2     | 0 | 0                     | 0    | 0     | 0 | 0                        | 0    | 0     | 0 | 0                        | 1    | 1     | 0 | 0     | 5             | 36 |
| 10:25 AM                        | 0                     | 0    | 1     | 0 | 0                     | 1    | 0     | 0 | 0                        | 0    | 0     | 1 | 0                        | 2    | 0     | 0 | 0     | 5             | 36 |
| 10:30 AM                        | 0                     | 2    | 1     | 0 | 0                     | 1    | 0     | 0 | 0                        | 0    | 0     | 0 | 0                        | 1    | 0     | 0 | 0     | 5             | 38 |
| 10:35 AM                        | 1                     | 0    | 0     | 0 | 0                     | 1    | 0     | 0 | 0                        | 0    | 0     | 0 | 0                        | 0    | 0     | 0 | 0     | 2             | 36 |
| 10:40 AM                        | 1                     | 0    | 0     | 0 | 0                     | 0    | 0     | 0 | 0                        | 0    | 1     | 0 | 0                        | 0    | 0     | 0 | 0     | 2             | 36 |
| 10:45 AM                        | 0                     | 0    | 1     | 0 | 0                     | 0    | 0     | 0 | 0                        | 0    | 0     | 0 | 0                        | 1    | 0     | 0 | 0     | 2             | 37 |
| 10:50 AM                        | 1                     | 0    | 1     | 0 | 0                     | 0    | 0     | 0 | 0                        | 0    | 0     | 0 | 0                        | 1    | 0     | 0 | 0     | 3             | 35 |
| 10:55 AM                        | 0                     | 1    | 1     | 0 | 0                     | 0    | 0     | 0 | 0                        | 0    | 0     | 0 | 0                        | 0    | 0     | 0 | 0     | 2             | 37 |
| 11:00 AM                        | 1                     | 1    | 0     | 0 | 0                     | 1    | 0     | 0 | 0                        | 0    | 0     | 0 | 0                        | 0    | 0     | 0 | 0     | 3             | 37 |
| 11:05 AM                        | 0                     | 0    | 1     | 0 | 0                     | 1    | 0     | 0 | 0                        | 0    | 0     | 1 | 0                        | 0    | 0     | 0 | 0     | 3             | 37 |
| 11:10 AM                        | 0                     | 2    | 1     | 0 | 0                     | 0    | 0     | 0 | 0                        | 0    | 0     | 1 | 0                        | 0    | 0     | 0 | 0     | 4             | 38 |
| 11:15 AM                        | 0                     | 0    | 0     | 0 | 0                     | 0    | 0     | 0 | 0                        | 0    | 0     | 0 | 0                        | 2    | 0     | 0 | 0     | 2             | 38 |
| 11:20 AM                        | 0                     | 1    | 1     | 0 | 0                     | 1    | 1     | 0 | 0                        | 0    | 0     | 0 | 0                        | 0    | 1     | 0 | 0     | 5             | 38 |
| 11:25 AM                        | 0                     | 1    | 1     | 0 | 0                     | 0    | 0     | 0 | 0                        | 0    | 0     | 1 | 0                        | 1    | 0     | 1 | 0     | 5             | 38 |
| 11:30 AM                        | 0                     | 0    | 1     | 0 | 0                     | 0    | 0     | 0 | 0                        | 0    | 0     | 1 | 0                        | 3    | 0     | 0 | 0     | 5             | 38 |
| 11:35 AM                        | 0                     | 1    | 0     | 0 | 0                     | 0    | 0     | 0 | 0                        | 0    | 0     | 2 | 0                        | 0    | 0     | 0 | 0     | 3             | 39 |
| 11:40 AM                        | 1                     | 1    | 1     | 0 | 0                     | 2    | 0     | 0 | 0                        | 0    | 0     | 0 | 0                        | 0    | 0     | 0 | 0     | 5             | 42 |
| 11:45 AM                        | 1                     | 0    | 0     | 0 | 0                     | 0    | 0     | 0 | 0                        | 0    | 0     | 0 | 0                        | 0    | 0     | 0 | 0     | 1             | 41 |
| 11:50 AM                        | 0                     | 0    | 2     | 0 | 0                     | 0    | 0     | 0 | 0                        | 0    | 0     | 0 | 0                        | 0    | 0     | 0 | 0     | 2             | 40 |
| 11:55 AM                        | 2                     | 0    | 0     | 0 | 0                     | 0    | 0     | 0 | 0                        | 0    | 0     | 0 | 0                        | 0    | 0     | 0 | 0     | 2             | 40 |
| 12:00 PM                        | 1                     | 0    | 0     | 0 | 0                     | 0    | 0     | 0 | 0                        | 0    | 0     | 0 | 0                        | 1    | 0     | 0 | 0     | 2             | 39 |
| 12:05 PM                        | 0                     | 0    | 1     | 0 | 0                     | 1    | 0     | 0 | 0                        | 0    | 0     | 2 | 0                        | 0    | 0     | 0 | 0     | 4             | 40 |
| 12:10 PM                        | 2                     | 0    | 0     | 0 | 0                     | 0    | 0     | 0 | 0                        | 0    | 0     | 0 | 0                        | 1    | 0     | 0 | 0     | 3             | 39 |
| 12:15 PM                        | 0                     | 1    | 1     | 0 | 0                     | 1    | 0     | 0 | 0                        | 0    | 0     | 1 | 0                        | 0    | 1     | 0 | 0     | 5             | 42 |
| 12:20 PM                        | 2                     | 1    | 0     | 0 | 0                     | 1    | 0     | 0 | 0                        | 0    | 0     | 1 | 0                        | 1    | 0     | 0 | 0     | 6             | 43 |
| 12:25 PM                        | 0                     | 0    | 0     | 0 | 0                     | 0    | 0     | 0 | 0                        | 0    | 0     | 1 | 0                        | 1    | 0     | 1 | 0     | 3             | 41 |
| 12:30 PM                        | 1                     | 0    | 0     | 0 | 0                     | 1    | 0     | 0 | 0                        | 0    | 0     | 2 | 0                        | 3    | 0     | 0 | 0     | 7             | 43 |
| 12:35 PM                        | 0                     | 1    | 0     | 0 | 0                     | 1    | 0     | 0 | 0                        | 0    | 0     | 1 | 0                        | 0    | 0     | 0 | 0     | 3             | 43 |
| 12:40 PM                        | 1                     | 0    | 1     | 0 | 0                     | 1    | 0     | 0 | 0                        | 0    | 0     | 0 | 0                        | 0    | 1     | 0 | 0     | 4             | 42 |
| 12:45 PM                        | 0                     | 0    | 0     | 0 | 0                     | 0    | 0     | 0 | 0                        | 0    | 0     | 0 | 0                        | 1    | 0     | 0 | 0     | 1             | 42 |
| 12:50 PM                        | 0                     | 1    | 1     | 0 | 0                     | 1    | 0     | 0 | 0                        | 0    | 0     | 1 | 0                        | 0    | 0     | 0 | 0     | 4             | 44 |
| 12:55 PM                        | 0                     | 2    | 1     | 0 | 0                     | 2    | 0     | 0 | 0                        | 0    | 0     | 0 | 0                        | 0    | 0     | 0 | 0     | 5             | 47 |
| 1:00 PM                         | 0                     | 0    | 0     | 0 | 0                     | 0    | 0     | 0 | 0                        | 0    | 0     | 0 | 0                        | 1    | 0     | 0 | 0     | 1             | 46 |
| 1:05 PM                         | 0                     | 2    | 2     | 0 | 0                     | 0    | 0     | 0 | 0                        | 0    | 0     | 0 | 0                        | 1    | 0     | 0 | 0     | 5             | 47 |
| 1:10 PM                         | 1                     | 1    | 0     | 0 | 0                     | 2    | 0     | 0 | 0                        | 0    | 0     | 1 | 0                        | 0    | 0     | 0 | 0     | 5             | 49 |
| 1:15 PM                         | 0                     | 1    | 0     | 0 | 0                     | 1    | 0     | 0 | 0                        | 0    | 0     | 0 | 0                        | 0    | 0     | 0 | 0     | 2             | 46 |
| 1:20 PM                         | 1                     | 1    | 0     | 0 | 0                     | 1    | 0     | 0 | 0                        | 0    | 0     | 0 | 0                        | 1    | 0     | 0 | 0     | 4             | 44 |
| 1:25 PM                         | 0                     | 1    | 0     | 0 | 0                     | 1    | 0     | 0 | 0                        | 0    | 0     | 1 | 0                        | 0    | 0     | 0 | 0     | 3             | 44 |
| 1:30 PM                         | 1                     | 0    | 0     | 0 | 0                     | 0    | 0     | 0 | 0                        | 0    | 0     | 0 | 0                        | 1    | 0     | 0 | 0     | 2             | 39 |
| 1:35 PM                         | 0                     | 2    | 0     | 0 | 0                     | 0    | 0     | 0 | 0                        | 0    | 0     | 3 | 0                        | 0    | 0     | 0 | 0     | 5             | 41 |
| 1:40 PM                         | 0                     | 1    | 0     | 0 | 0                     | 1    | 0     | 0 | 0                        | 1    | 0     | 0 | 0                        | 1    | 1     | 0 | 0     | 5             | 42 |
| 1:45 PM                         | 0                     | 0    | 0     | 0 | 0                     | 2    | 0     | 0 | 0                        | 0    | 0     | 1 | 0                        | 1    | 0     | 0 | 0     | 4             | 45 |
| 1:50 PM                         | 0                     | 1    | 1     | 0 | 0                     | 0    | 0     | 0 | 0                        | 0    | 0     | 0 | 0                        | 0    | 0     | 0 | 0     | 2             | 43 |
| 1:55 PM                         | 0                     | 0    | 0     | 0 | 0                     | 0    | 0     | 0 | 0                        | 0    | 0     | 1 | 0                        | 0    | 0     | 0 | 0     | 1             | 39 |
| 2:00 PM                         | 0                     | 2    | 1     | 0 | 0                     | 0    | 0     | 0 | 0                        | 0    | 0     | 0 | 0                        | 0    | 0     | 0 | 0     | 3             | 41 |
| 2:05 PM                         | 1                     | 2    | 0     | 0 | 0                     | 1    | 0     | 0 | 0                        | 0    | 1     | 0 | 0                        | 1    | 0     | 0 | 0     | 6             | 42 |
| 2:10 PM                         | 0                     | 1    | 0     | 0 | 1                     | 0    | 0     | 0 | 0                        | 0    | 0     | 1 | 0                        | 0    | 0     | 0 | 0     | 3             | 40 |
| 2:15 PM                         | 0                     | 0    | 0     | 0 | 1                     | 2    | 0     | 0 | 0                        | 0    | 0     | 0 | 0                        | 0    | 0     | 0 | 0     | 3             | 41 |
| 2:20 PM                         | 1                     | 0    | 0     | 0 | 0                     | 3    | 0     | 0 | 0                        | 0    | 1     | 0 | 0                        | 0    | 0     | 1 | 0     | 6             | 43 |
| 2:25 PM                         | 0                     | 0    | 0     | 0 | 0                     | 3    | 0     | 0 | 0                        | 0    | 0     | 0 | 0                        | 0    | 0     | 0 | 0     | 3             | 43 |
| 2:30 PM                         | 1                     | 0    | 1     | 0 | 0                     | 2    | 0     | 0 | 0                        | 0    | 0     | 1 | 0                        | 3    | 0     | 0 | 0     | 8             | 49 |
| 2:35 PM                         | 0                     | 1    | 0     | 0 | 0                     | 3    | 0     | 0 | 0                        | 0    | 0     | 0 | 0                        | 0    | 0     | 0 | 0     | 4             | 48 |
| 2:40 PM                         | 0                     | 0    | 0     | 0 | 0                     | 0    | 0     | 0 | 0                        | 0    | 0     | 0 | 0                        | 0    | 0     | 1 | 0     | 1             | 44 |
| 2:45 PM                         | 0                     | 0    | 0     | 0 | 0                     | 1    | 0     | 0 | 0                        | 0    | 0     | 0 | 0                        | 1    | 0     | 0 | 0     | 2             | 42 |
| 2:50 PM                         | 2                     | 0    | 1     | 0 | 0                     | 1    | 0     | 0 | 0                        | 1    | 0     | 0 | 0                        | 0    | 0     | 0 | 0     | 5             | 45 |
| 2:55 PM                         | 2                     | 0    | 0     | 0 | 0                     | 3    | 0     | 0 | 0                        | 0    | 0     | 0 | 0                        | 1    | 0     | 0 | 0     | 6             | 50 |
| 3:00 PM                         | 1                     | 1    | 1     | 0 | 0                     | 1    | 0     | 0 | 0                        | 0    | 0     | 0 | 0                        | 0    | 1     | 0 | 0     | 5             | 52 |
| 3:05 PM                         | 0                     | 1    | 1     | 0 | 0                     | 1    | 0     | 0 | 0                        | 1    | 0     | 3 | 0                        | 0    | 0     | 0 | 0     | 7             | 53 |
| 3:10 PM                         | 0                     | 0    | 0     | 0 | 0                     | 1    | 0     | 0 | 0                        | 0    | 0     | 1 | 0                        | 1    | 0     | 2 | 0     | 5             | 55 |
| 3:15 PM                         | 0                     | 1    | 0     | 0 | 0                     | 0    | 0     | 0 | 0                        | 0    | 0     | 0 | 0                        | 0    | 0     | 0 | 0     | 1             | 53 |
| 3:20 PM                         | 0                     | 1    | 1     | 0 | 0                     | 0    | 0     | 0 | 0                        | 0    | 0     | 0 | 0                        | 0    | 0     | 0 | 0     | 2             | 49 |
| 3:25 PM                         | 1                     | 1    | 0     | 0 | 0                     | 1    | 1     | 0 | 0                        | 0    | 0     | 1 | 0                        | 0    | 0     | 0 | 0     | 5             | 51 |
| 3:30 PM                         | 0                     | 2    | 0     | 0 | 0                     | 1    | 0     | 0 | 0                        | 0    | 0     | 1 | 0                        | 4    | 1     | 0 | 0     | 9             | 52 |
| 3:35 PM                         | 1                     | 0    | 1     | 0 | 0                     | 2    | 1     | 0 | 0                        | 0    | 0     | 1 | 0                        | 4    | 0     | 0 | 0     | 10            | 58 |
| 3:40 PM                         | 1                     | 2    | 1     | 0 | 0                     | 1    | 0     | 0 | 0                        | 0    | 0     | 0 | 0                        | 2    | 0     | 0 | 0     | 7             | 64 |
| 3:45 PM                         | 0                     | 3    | 1     | 0 | 0                     | 1    | 0     | 0 | 0                        | 0    | 0     | 1 | 0                        | 2    | 0     | 0 | 0     | 8             | 70 |
| 3:50 PM                         | 0                     | 2    | 0     | 0 | 0                     | 0    | 0     | 0 | 0                        | 0    | 0     | 0 | 0                        | 0    | 0     | 0 | 0     | 2             | 67 |
| 3:55 PM                         | 0                     | 0    | 0     | 0 | 0                     | 0    | 0     | 0 | 0                        | 0    | 0     | 0 | 0                        | 1    | 0     | 0 | 0     | 1             | 62 |
| 4:00 PM                         | 1                     | 1    | 1     | 0 | 0                     | 0    | 0     | 0 | 0                        | 0    | 0     | 1 | 0                        | 0    | 0     | 0 | 0     | 4             | 61 |
| 4:05 PM                         | 0                     | 0    | 1     | 0 | 0                     | 0    | 0     | 0 | 0                        | 0    | 0     | 0 | 0                        | 1    | 0     | 0 | 0     | 2             | 56 |
| 4:10 PM                         | 0                     | 2    | 0     | 0 | 0                     | 2    | 0     | 0 | 0                        | 0    | 0     | 2 | 0                        | 0    | 0     | 0 | 0     | 6             | 57 |
| 4:15 PM                         | 1                     | 0    | 0     | 0 | 0                     | 0    | 0     | 0 | 0                        | 0    | 0     | 0 | 0                        | 0    | 0     | 0 | 0     | 1             | 57 |
| 4:20 PM                         | 0                     | 0    | 0     | 0 | 0                     | 0    | 0     | 0 | 0                        | 0    | 0     | 0 | 0                        | 0    | 0     | 0 | 0     | 0             | 55 |
| 4:25 PM                         | 0                     | 1    | 0     | 0 | 0                     | 0    | 0     | 0 | 0                        | 0    | 0     | 1 | 0                        | 1    | 0     | 0 | 0     | 3             | 53 |

**Attachment B**

| 5-Min Count Period Beginning At | Brier Ln (Northbound) |      |       |   | Brier Ln (Southbound) |      |       |   | Highcliff Dr (Eastbound) |      |       |   | Highcliff Dr (Westbound) |      |       |   | Total | Hourly Totals |
|---------------------------------|-----------------------|------|-------|---|-----------------------|------|-------|---|--------------------------|------|-------|---|--------------------------|------|-------|---|-------|---------------|
|                                 | Left                  | Thru | Right | U | Left                  | Thru | Right | U | Left                     | Thru | Right | U | Left                     | Thru | Right | U |       |               |
| 4:30 PM                         | 0                     | 0    | 0     | 0 | 0                     | 0    | 0     | 0 | 0                        | 0    | 0     | 0 | 1                        | 0    | 0     | 0 | 1     | 45            |
| 4:35 PM                         | 0                     | 2    | 0     | 0 | 0                     | 0    | 0     | 0 | 0                        | 0    | 0     | 0 | 1                        | 0    | 0     | 0 | 3     | 38            |
| 4:40 PM                         | 0                     | 1    | 0     | 0 | 0                     | 1    | 0     | 0 | 0                        | 0    | 0     | 0 | 0                        | 0    | 0     | 0 | 2     | 33            |
| 4:45 PM                         | 0                     | 1    | 1     | 0 | 0                     | 1    | 0     | 0 | 0                        | 0    | 1     | 0 | 0                        | 0    | 0     | 0 | 4     | 29            |
| 4:50 PM                         | 0                     | 0    | 1     | 0 | 1                     | 2    | 0     | 0 | 0                        | 0    | 3     | 0 | 0                        | 0    | 0     | 0 | 7     | 34            |
| 4:55 PM                         | 0                     | 0    | 0     | 0 | 0                     | 1    | 0     | 0 | 0                        | 0    | 3     | 0 | 0                        | 0    | 0     | 0 | 4     | 37            |
| 5:00 PM                         | 0                     | 0    | 0     | 0 | 0                     | 0    | 0     | 0 | 0                        | 0    | 0     | 0 | 0                        | 0    | 0     | 0 | 0     | 33            |
| 5:05 PM                         | 0                     | 0    | 1     | 0 | 0                     | 0    | 0     | 0 | 0                        | 0    | 0     | 0 | 0                        | 0    | 0     | 0 | 1     | 32            |
| 5:10 PM                         | 0                     | 2    | 0     | 0 | 2                     | 2    | 0     | 0 | 0                        | 0    | 0     | 0 | 0                        | 0    | 0     | 0 | 6     | 32            |
| 5:15 PM                         | 0                     | 0    | 0     | 0 | 0                     | 0    | 0     | 0 | 0                        | 0    | 1     | 0 | 0                        | 0    | 0     | 0 | 1     | 32            |
| 5:20 PM                         | 1                     | 0    | 0     | 0 | 0                     | 1    | 0     | 0 | 0                        | 0    | 0     | 0 | 1                        | 0    | 0     | 0 | 3     | 35            |
| 5:25 PM                         | 0                     | 0    | 0     | 0 | 0                     | 1    | 0     | 0 | 0                        | 0    | 0     | 0 | 0                        | 0    | 0     | 0 | 1     | 33            |
| 5:30 PM                         | 0                     | 0    | 1     | 0 | 0                     | 0    | 0     | 0 | 0                        | 0    | 1     | 0 | 1                        | 0    | 0     | 0 | 3     | 35            |
| 5:35 PM                         | 1                     | 1    | 0     | 0 | 0                     | 1    | 0     | 0 | 0                        | 0    | 0     | 0 | 1                        | 0    | 0     | 0 | 4     | 36            |
| 5:40 PM                         | 0                     | 1    | 0     | 0 | 0                     | 0    | 0     | 0 | 0                        | 0    | 2     | 0 | 0                        | 0    | 0     | 0 | 3     | 37            |
| 5:45 PM                         | 0                     | 1    | 0     | 0 | 0                     | 0    | 0     | 0 | 0                        | 0    | 0     | 0 | 0                        | 0    | 0     | 0 | 1     | 34            |
| 5:50 PM                         | 0                     | 1    | 0     | 0 | 0                     | 0    | 0     | 0 | 0                        | 0    | 0     | 0 | 1                        | 0    | 0     | 0 | 2     | 29            |
| 5:55 PM                         | 1                     | 1    | 1     | 0 | 0                     | 0    | 0     | 0 | 0                        | 0    | 0     | 0 | 1                        | 0    | 0     | 0 | 4     | 29            |
| 6:00 PM                         | 1                     | 1    | 0     | 0 | 0                     | 0    | 0     | 0 | 0                        | 0    | 0     | 0 | 0                        | 0    | 0     | 0 | 2     | 31            |
| 6:05 PM                         | 0                     | 0    | 0     | 0 | 0                     | 1    | 0     | 0 | 0                        | 0    | 0     | 0 | 0                        | 0    | 0     | 0 | 1     | 31            |
| 6:10 PM                         | 2                     | 0    | 0     | 0 | 0                     | 0    | 0     | 0 | 0                        | 0    | 0     | 0 | 0                        | 0    | 0     | 0 | 2     | 27            |
| 6:15 PM                         | 1                     | 1    | 0     | 0 | 0                     | 1    | 0     | 0 | 0                        | 0    | 2     | 0 | 0                        | 0    | 0     | 0 | 5     | 31            |
| 6:20 PM                         | 0                     | 1    | 0     | 0 | 0                     | 0    | 0     | 0 | 0                        | 1    | 0     | 0 | 0                        | 0    | 0     | 0 | 2     | 30            |
| 6:25 PM                         | 0                     | 1    | 1     | 0 | 0                     | 2    | 0     | 0 | 0                        | 0    | 0     | 0 | 0                        | 0    | 0     | 0 | 4     | 33            |
| 6:30 PM                         | 1                     | 0    | 0     | 0 | 0                     | 1    | 0     | 0 | 0                        | 0    | 1     | 0 | 0                        | 0    | 0     | 0 | 3     | 33            |
| 6:35 PM                         | 0                     | 1    | 0     | 0 | 0                     | 0    | 0     | 0 | 0                        | 0    | 1     | 0 | 0                        | 0    | 0     | 0 | 2     | 31            |
| 6:40 PM                         | 1                     | 1    | 0     | 0 | 0                     | 1    | 0     | 0 | 0                        | 0    | 0     | 0 | 0                        | 0    | 0     | 0 | 3     | 31            |
| 6:45 PM                         | 0                     | 0    | 1     | 0 | 0                     | 2    | 0     | 0 | 0                        | 0    | 0     | 0 | 0                        | 0    | 0     | 0 | 3     | 33            |
| 6:50 PM                         | 0                     | 0    | 0     | 0 | 0                     | 0    | 0     | 0 | 0                        | 0    | 0     | 0 | 0                        | 0    | 0     | 0 | 0     | 31            |
| 6:55 PM                         | 0                     | 1    | 0     | 0 | 0                     | 0    | 0     | 0 | 0                        | 0    | 0     | 0 | 0                        | 0    | 0     | 0 | 1     | 28            |
| 7:00 PM                         | 0                     | 1    | 0     | 0 | 0                     | 0    | 0     | 0 | 0                        | 0    | 0     | 0 | 0                        | 0    | 0     | 0 | 1     | 27            |
| 7:05 PM                         | 0                     | 0    | 0     | 0 | 0                     | 1    | 0     | 0 | 0                        | 0    | 0     | 0 | 0                        | 0    | 0     | 0 | 1     | 27            |
| 7:10 PM                         | 0                     | 2    | 0     | 0 | 0                     | 0    | 0     | 0 | 0                        | 0    | 0     | 0 | 0                        | 0    | 0     | 0 | 2     | 27            |
| 7:15 PM                         | 0                     | 3    | 0     | 0 | 0                     | 1    | 0     | 0 | 0                        | 0    | 0     | 0 | 1                        | 0    | 0     | 0 | 5     | 27            |
| 7:20 PM                         | 0                     | 0    | 0     | 0 | 0                     | 0    | 0     | 0 | 0                        | 0    | 0     | 0 | 0                        | 0    | 0     | 0 | 0     | 25            |
| 7:25 PM                         | 0                     | 1    | 0     | 0 | 0                     | 1    | 0     | 0 | 0                        | 0    | 0     | 0 | 0                        | 0    | 0     | 0 | 2     | 23            |
| 7:30 PM                         | 0                     | 0    | 0     | 0 | 0                     | 1    | 0     | 0 | 0                        | 0    | 0     | 0 | 0                        | 0    | 0     | 0 | 1     | 21            |
| 7:35 PM                         | 1                     | 1    | 0     | 0 | 0                     | 1    | 0     | 0 | 0                        | 0    | 0     | 0 | 0                        | 0    | 0     | 0 | 3     | 22            |
| 7:40 PM                         | 0                     | 3    | 0     | 0 | 0                     | 0    | 0     | 0 | 0                        | 0    | 0     | 0 | 1                        | 0    | 0     | 0 | 4     | 23            |
| 7:45 PM                         | 0                     | 1    | 0     | 0 | 0                     | 0    | 0     | 0 | 0                        | 0    | 0     | 0 | 0                        | 0    | 0     | 0 | 1     | 21            |
| 7:50 PM                         | 0                     | 0    | 0     | 0 | 0                     | 0    | 0     | 0 | 0                        | 0    | 0     | 0 | 0                        | 0    | 0     | 0 | 0     | 21            |
| 7:55 PM                         | 0                     | 1    | 0     | 0 | 0                     | 0    | 0     | 0 | 0                        | 0    | 0     | 0 | 1                        | 0    | 0     | 0 | 2     | 22            |
| 8:00 PM                         | 0                     | 0    | 1     | 0 | 0                     | 0    | 0     | 0 | 0                        | 0    | 0     | 0 | 1                        | 1    | 0     | 0 | 3     | 24            |
| 8:05 PM                         | 1                     | 1    | 0     | 0 | 0                     | 0    | 0     | 0 | 0                        | 1    | 0     | 0 | 0                        | 0    | 0     | 0 | 3     | 26            |
| 8:10 PM                         | 0                     | 0    | 0     | 0 | 0                     | 0    | 0     | 0 | 0                        | 0    | 0     | 0 | 0                        | 0    | 0     | 0 | 0     | 24            |
| 8:15 PM                         | 0                     | 0    | 0     | 0 | 0                     | 0    | 0     | 0 | 0                        | 0    | 0     | 0 | 1                        | 0    | 0     | 0 | 1     | 20            |
| 8:20 PM                         | 0                     | 0    | 1     | 0 | 0                     | 0    | 0     | 0 | 0                        | 0    | 0     | 0 | 1                        | 0    | 0     | 0 | 2     | 22            |
| 8:25 PM                         | 2                     | 0    | 0     | 0 | 0                     | 0    | 0     | 0 | 0                        | 0    | 1     | 0 | 0                        | 0    | 0     | 0 | 3     | 23            |
| 8:30 PM                         | 0                     | 0    | 0     | 0 | 0                     | 0    | 0     | 0 | 0                        | 0    | 0     | 0 | 0                        | 0    | 0     | 0 | 0     | 22            |
| 8:35 PM                         | 0                     | 0    | 0     | 0 | 0                     | 0    | 0     | 0 | 0                        | 0    | 0     | 0 | 1                        | 0    | 0     | 0 | 1     | 20            |
| 8:40 PM                         | 0                     | 0    | 1     | 0 | 0                     | 0    | 0     | 0 | 0                        | 0    | 0     | 0 | 0                        | 0    | 0     | 0 | 1     | 17            |
| 8:45 PM                         | 0                     | 0    | 0     | 0 | 0                     | 0    | 0     | 0 | 0                        | 0    | 0     | 0 | 0                        | 0    | 0     | 0 | 0     | 16            |
| 8:50 PM                         | 0                     | 0    | 0     | 0 | 0                     | 0    | 0     | 0 | 0                        | 0    | 0     | 0 | 1                        | 0    | 0     | 0 | 1     | 17            |
| 8:55 PM                         | 0                     | 0    | 0     | 0 | 0                     | 0    | 0     | 0 | 0                        | 0    | 0     | 0 | 0                        | 0    | 0     | 0 | 0     | 15            |
| 9:00 PM                         | 0                     | 0    | 0     | 0 | 0                     | 0    | 0     | 0 | 0                        | 0    | 0     | 0 | 0                        | 0    | 0     | 0 | 0     | 12            |
| 9:05 PM                         | 0                     | 0    | 0     | 0 | 0                     | 0    | 0     | 0 | 0                        | 0    | 0     | 0 | 0                        | 0    | 0     | 0 | 0     | 9             |
| 9:10 PM                         | 0                     | 0    | 0     | 0 | 0                     | 0    | 0     | 0 | 0                        | 0    | 0     | 0 | 0                        | 0    | 0     | 0 | 0     | 9             |
| 9:15 PM                         | 0                     | 0    | 0     | 0 | 0                     | 0    | 0     | 0 | 0                        | 0    | 0     | 0 | 0                        | 0    | 0     | 0 | 0     | 8             |
| 9:20 PM                         | 0                     | 1    | 0     | 0 | 0                     | 0    | 0     | 0 | 0                        | 0    | 0     | 0 | 0                        | 0    | 0     | 0 | 1     | 7             |
| 9:25 PM                         | 0                     | 0    | 0     | 0 | 0                     | 0    | 0     | 0 | 0                        | 0    | 0     | 0 | 0                        | 0    | 0     | 0 | 0     | 4             |
| 9:30 PM                         | 0                     | 1    | 0     | 0 | 0                     | 0    | 0     | 0 | 0                        | 0    | 0     | 0 | 0                        | 0    | 1     | 0 | 2     | 6             |
| 9:35 PM                         | 1                     | 0    | 0     | 0 | 0                     | 1    | 0     | 0 | 0                        | 0    | 0     | 0 | 0                        | 0    | 0     | 0 | 2     | 7             |
| 9:40 PM                         | 0                     | 1    | 0     | 0 | 0                     | 1    | 0     | 0 | 0                        | 0    | 0     | 0 | 0                        | 0    | 0     | 0 | 2     | 8             |
| 9:45 PM                         | 0                     | 0    | 0     | 0 | 0                     | 0    | 0     | 0 | 0                        | 0    | 0     | 0 | 0                        | 0    | 0     | 0 | 0     | 8             |
| 9:50 PM                         | 0                     | 3    | 0     | 0 | 0                     | 0    | 0     | 0 | 0                        | 0    | 0     | 0 | 0                        | 0    | 0     | 0 | 3     | 10            |
| 9:55 PM                         | 0                     | 0    | 0     | 0 | 0                     | 0    | 0     | 0 | 0                        | 0    | 0     | 0 | 0                        | 0    | 0     | 0 | 0     | 10            |
| Peak 15-Min Flowrates           | Northbound            |      |       |   | Southbound            |      |       |   | Eastbound                |      |       |   | Westbound                |      |       |   | Total |               |
|                                 | Left                  | Thru | Right | U | Left                  | Thru | Right | U | Left                     | Thru | Right | U | Left                     | Thru | Right | U |       |               |
| All Vehicles                    | 8                     | 16   | 8     | 0 | 0                     | 16   | 4     | 0 | 0                        | 0    | 8     | 0 | 40                       | 4    | 0     | 0 | 104   |               |
| Heavy Trucks                    | 0                     | 0    | 0     | 0 | 0                     | 0    | 0     | 0 | 0                        | 0    | 0     | 0 | 4                        | 0    | 0     | 0 | 4     |               |
| Buses                           |                       |      |       |   |                       |      |       |   |                          |      |       |   |                          |      |       |   |       |               |
| Pedestrians                     |                       | 0    |       |   |                       | 0    |       |   |                          | 0    |       |   |                          | 0    |       |   | 0     |               |
| Bicycles                        | 0                     | 0    | 0     |   | 0                     | 0    | 0     |   | 0                        | 0    | 0     |   | 0                        | 0    | 0     |   | 0     |               |
| Scoters                         |                       |      |       |   |                       |      |       |   |                          |      |       |   |                          |      |       |   |       |               |
| <i>Comments:</i>                |                       |      |       |   |                       |      |       |   |                          |      |       |   |                          |      |       |   |       |               |

LOCATION: Overhill Dr -- Deerhaven Dr  
 CITY/STATE: North Tustin, CA

QC JOB #: 16966434  
 DATE: Thu, Apr 10 2025

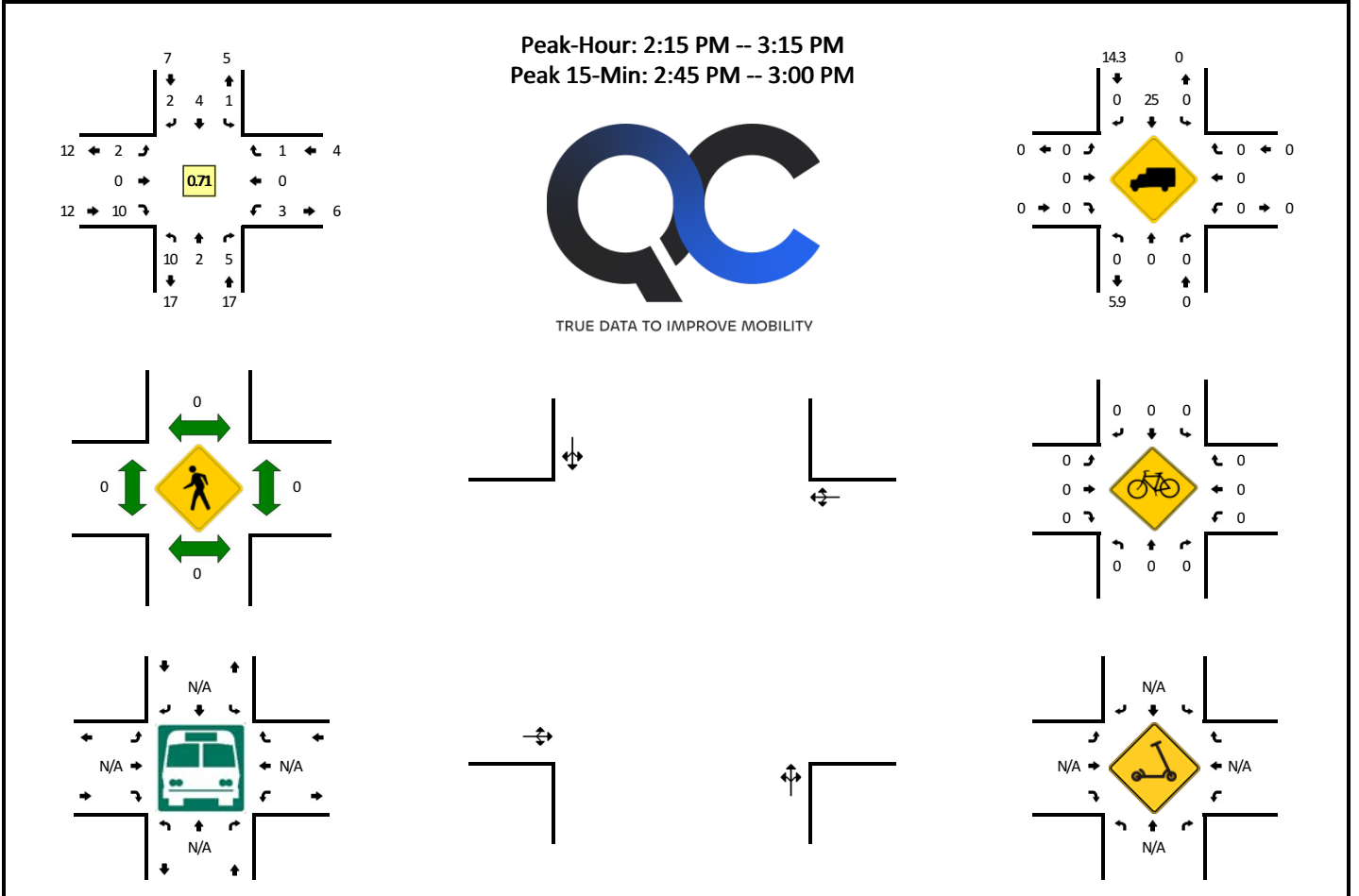

| 5-Min Count Period Beginning At | Overhill Dr (Northbound) |      |       |   | Overhill Dr (Southbound) |      |       |   | Deerhaven Dr (Eastbound) |      |       |   | Deerhaven Dr (Westbound) |      |       |   | Total | Hourly Totals |
|---------------------------------|--------------------------|------|-------|---|--------------------------|------|-------|---|--------------------------|------|-------|---|--------------------------|------|-------|---|-------|---------------|
|                                 | Left                     | Thru | Right | U | Left                     | Thru | Right | U | Left                     | Thru | Right | U | Left                     | Thru | Right | U |       |               |
| 6:00 AM                         | 0                        | 0    | 0     | 0 | 0                        | 0    | 0     | 0 | 0                        | 0    | 0     | 0 | 0                        | 0    | 0     | 0 | 0     | 0             |
| 6:05 AM                         | 0                        | 0    | 0     | 0 | 0                        | 0    | 0     | 0 | 0                        | 0    | 0     | 1 | 0                        | 0    | 0     | 0 | 0     | 1             |
| 6:10 AM                         | 0                        | 0    | 0     | 0 | 0                        | 0    | 0     | 0 | 0                        | 0    | 0     | 0 | 0                        | 0    | 0     | 0 | 0     | 0             |
| 6:15 AM                         | 0                        | 0    | 1     | 0 | 0                        | 0    | 0     | 0 | 0                        | 1    | 0     | 0 | 0                        | 0    | 1     | 0 | 0     | 3             |
| 6:20 AM                         | 0                        | 0    | 0     | 0 | 0                        | 0    | 0     | 0 | 0                        | 0    | 0     | 0 | 0                        | 0    | 0     | 0 | 0     | 0             |
| 6:25 AM                         | 2                        | 0    | 0     | 0 | 0                        | 0    | 0     | 0 | 0                        | 0    | 0     | 0 | 0                        | 0    | 0     | 0 | 0     | 2             |
| 6:30 AM                         | 0                        | 0    | 0     | 0 | 0                        | 0    | 0     | 0 | 0                        | 0    | 0     | 1 | 0                        | 0    | 0     | 0 | 0     | 1             |
| 6:35 AM                         | 0                        | 0    | 0     | 0 | 0                        | 0    | 0     | 0 | 0                        | 0    | 0     | 0 | 0                        | 1    | 0     | 0 | 0     | 1             |
| 6:40 AM                         | 0                        | 0    | 0     | 0 | 0                        | 1    | 0     | 0 | 0                        | 0    | 0     | 0 | 0                        | 0    | 0     | 0 | 0     | 1             |
| 6:45 AM                         | 0                        | 0    | 0     | 0 | 0                        | 0    | 0     | 0 | 0                        | 0    | 0     | 1 | 0                        | 0    | 0     | 0 | 0     | 1             |
| 6:50 AM                         | 0                        | 0    | 0     | 0 | 0                        | 0    | 0     | 0 | 0                        | 0    | 0     | 1 | 0                        | 0    | 0     | 0 | 0     | 1             |
| 6:55 AM                         | 0                        | 0    | 0     | 0 | 0                        | 0    | 0     | 0 | 0                        | 0    | 0     | 0 | 0                        | 0    | 0     | 0 | 0     | 0             |
| 7:00 AM                         | 1                        | 0    | 0     | 0 | 0                        | 0    | 0     | 0 | 0                        | 0    | 0     | 0 | 0                        | 0    | 0     | 0 | 0     | 1             |
| 7:05 AM                         | 0                        | 1    | 0     | 0 | 0                        | 0    | 0     | 0 | 0                        | 0    | 0     | 0 | 0                        | 0    | 0     | 0 | 0     | 1             |
| 7:10 AM                         | 0                        | 0    | 0     | 0 | 0                        | 0    | 0     | 0 | 0                        | 0    | 0     | 0 | 0                        | 0    | 0     | 0 | 0     | 0             |
| 7:15 AM                         | 0                        | 0    | 0     | 0 | 0                        | 0    | 0     | 0 | 0                        | 0    | 0     | 0 | 0                        | 0    | 0     | 0 | 0     | 0             |
| 7:20 AM                         | 2                        | 0    | 0     | 0 | 0                        | 0    | 0     | 0 | 0                        | 0    | 0     | 2 | 0                        | 0    | 0     | 0 | 0     | 4             |
| 7:25 AM                         | 0                        | 0    | 0     | 0 | 0                        | 0    | 0     | 0 | 0                        | 0    | 0     | 1 | 0                        | 0    | 0     | 0 | 0     | 1             |
| 7:30 AM                         | 1                        | 0    | 0     | 0 | 0                        | 0    | 0     | 0 | 0                        | 0    | 0     | 1 | 0                        | 0    | 0     | 0 | 0     | 2             |
| 7:35 AM                         | 0                        | 0    | 0     | 0 | 0                        | 0    | 0     | 0 | 0                        | 0    | 0     | 1 | 0                        | 0    | 0     | 0 | 0     | 1             |
| 7:40 AM                         | 1                        | 0    | 2     | 0 | 0                        | 0    | 0     | 0 | 0                        | 0    | 0     | 0 | 0                        | 0    | 0     | 0 | 0     | 3             |
| 7:45 AM                         | 0                        | 0    | 0     | 0 | 0                        | 0    | 0     | 0 | 0                        | 0    | 0     | 0 | 2                        | 0    | 0     | 0 | 0     | 2             |
| 7:50 AM                         | 0                        | 0    | 0     | 0 | 0                        | 0    | 0     | 0 | 0                        | 0    | 0     | 0 | 0                        | 0    | 0     | 0 | 0     | 0             |
| 7:55 AM                         | 0                        | 1    | 0     | 0 | 0                        | 1    | 0     | 0 | 0                        | 0    | 0     | 0 | 1                        | 0    | 0     | 0 | 0     | 3             |
| 8:00 AM                         | 0                        | 0    | 0     | 0 | 0                        | 0    | 0     | 0 | 0                        | 0    | 0     | 0 | 0                        | 0    | 0     | 0 | 0     | 0             |
| 8:05 AM                         | 1                        | 0    | 0     | 0 | 0                        | 0    | 0     | 0 | 0                        | 0    | 0     | 2 | 0                        | 0    | 0     | 0 | 0     | 3             |
| 8:10 AM                         | 1                        | 0    | 1     | 0 | 0                        | 1    | 0     | 0 | 0                        | 0    | 0     | 1 | 0                        | 0    | 0     | 0 | 0     | 4             |
| 8:15 AM                         | 2                        | 0    | 0     | 0 | 0                        | 0    | 0     | 0 | 0                        | 0    | 0     | 1 | 0                        | 0    | 0     | 0 | 0     | 3             |
| 8:20 AM                         | 3                        | 0    | 0     | 0 | 0                        | 0    | 0     | 0 | 0                        | 0    | 0     | 3 | 0                        | 0    | 0     | 0 | 0     | 6             |
| 8:25 AM                         | 1                        | 1    | 0     | 0 | 0                        | 0    | 0     | 0 | 0                        | 0    | 0     | 1 | 0                        | 0    | 0     | 0 | 0     | 3             |
| 8:30 AM                         | 0                        | 0    | 0     | 0 | 0                        | 0    | 0     | 0 | 0                        | 0    | 0     | 0 | 0                        | 0    | 0     | 0 | 0     | 0             |
| 8:35 AM                         | 1                        | 0    | 1     | 0 | 0                        | 0    | 0     | 0 | 0                        | 0    | 0     | 1 | 0                        | 0    | 0     | 0 | 0     | 3             |
| 8:40 AM                         | 1                        | 1    | 0     | 0 | 0                        | 0    | 0     | 0 | 0                        | 0    | 0     | 0 | 0                        | 0    | 0     | 0 | 0     | 2             |
| 8:45 AM                         | 0                        | 0    | 0     | 0 | 0                        | 0    | 0     | 0 | 0                        | 0    | 0     | 0 | 1                        | 0    | 0     | 0 | 0     | 1             |
| 8:50 AM                         | 0                        | 1    | 0     | 0 | 0                        | 0    | 0     | 0 | 0                        | 0    | 0     | 1 | 0                        | 0    | 0     | 0 | 0     | 2             |
| 8:55 AM                         | 1                        | 0    | 0     | 0 | 0                        | 0    | 0     | 0 | 0                        | 0    | 0     | 0 | 0                        | 0    | 0     | 0 | 0     | 1             |
| 9:00 AM                         | 1                        | 0    | 0     | 0 | 0                        | 0    | 0     | 0 | 0                        | 0    | 0     | 0 | 0                        | 0    | 0     | 0 | 0     | 1             |
| 9:05 AM                         | 2                        | 0    | 0     | 0 | 0                        | 0    | 0     | 0 | 0                        | 0    | 0     | 2 | 0                        | 0    | 0     | 0 | 0     | 4             |

**Attachment B**

| 5-Min Count Period Beginning At | Overhill Dr (Northbound) |      |       |   | Overhill Dr (Southbound) |      |       |   | Deerhaven Dr (Eastbound) |      |       |   | Deerhaven Dr (Westbound) |      |       |   | Total | Hourly Totals |
|---------------------------------|--------------------------|------|-------|---|--------------------------|------|-------|---|--------------------------|------|-------|---|--------------------------|------|-------|---|-------|---------------|
|                                 | Left                     | Thru | Right | U | Left                     | Thru | Right | U | Left                     | Thru | Right | U | Left                     | Thru | Right | U |       |               |
| 9:10 AM                         | 0                        | 0    | 0     | 0 | 0                        | 0    | 0     | 0 | 0                        | 0    | 1     | 0 | 0                        | 0    | 0     | 0 | 1     | 27            |
| 9:15 AM                         | 0                        | 0    | 0     | 0 | 0                        | 0    | 0     | 0 | 0                        | 0    | 0     | 0 | 0                        | 0    | 0     | 0 | 0     | 24            |
| 9:20 AM                         | 1                        | 1    | 0     | 0 | 0                        | 0    | 1     | 0 | 0                        | 0    | 0     | 0 | 0                        | 0    | 0     | 0 | 3     | 21            |
| 9:25 AM                         | 0                        | 0    | 0     | 0 | 0                        | 1    | 0     | 0 | 0                        | 0    | 0     | 0 | 0                        | 0    | 0     | 0 | 1     | 19            |
| 9:30 AM                         | 1                        | 0    | 0     | 0 | 0                        | 1    | 0     | 0 | 0                        | 0    | 0     | 0 | 0                        | 0    | 0     | 0 | 2     | 21            |
| 9:35 AM                         | 0                        | 0    | 1     | 0 | 0                        | 1    | 0     | 0 | 0                        | 0    | 0     | 2 | 0                        | 0    | 0     | 0 | 4     | 22            |
| 9:40 AM                         | 1                        | 0    | 0     | 0 | 0                        | 0    | 0     | 0 | 1                        | 0    | 0     | 0 | 0                        | 0    | 0     | 0 | 2     | 22            |
| 9:45 AM                         | 0                        | 0    | 0     | 0 | 0                        | 0    | 0     | 0 | 0                        | 0    | 0     | 0 | 0                        | 0    | 0     | 0 | 0     | 21            |
| 9:50 AM                         | 2                        | 0    | 0     | 0 | 0                        | 0    | 0     | 0 | 0                        | 0    | 0     | 0 | 1                        | 0    | 0     | 0 | 3     | 22            |
| 9:55 AM                         | 1                        | 0    | 0     | 0 | 0                        | 1    | 0     | 0 | 0                        | 0    | 0     | 0 | 0                        | 0    | 0     | 0 | 2     | 23            |
| 10:00 AM                        | 0                        | 0    | 1     | 0 | 0                        | 0    | 0     | 0 | 1                        | 0    | 1     | 0 | 1                        | 0    | 0     | 0 | 4     | 26            |
| 10:05 AM                        | 3                        | 1    | 0     | 0 | 0                        | 0    | 0     | 0 | 0                        | 0    | 0     | 0 | 0                        | 0    | 0     | 0 | 4     | 26            |
| 10:10 AM                        | 0                        | 0    | 0     | 0 | 0                        | 2    | 0     | 0 | 0                        | 0    | 0     | 0 | 0                        | 0    | 0     | 0 | 2     | 27            |
| 10:15 AM                        | 1                        | 0    | 0     | 0 | 0                        | 0    | 0     | 0 | 0                        | 0    | 3     | 0 | 0                        | 0    | 0     | 0 | 4     | 31            |
| 10:20 AM                        | 0                        | 0    | 0     | 0 | 0                        | 0    | 0     | 0 | 0                        | 0    | 1     | 0 | 0                        | 0    | 0     | 0 | 1     | 29            |
| 10:25 AM                        | 1                        | 0    | 1     | 0 | 0                        | 0    | 0     | 0 | 0                        | 0    | 1     | 0 | 0                        | 0    | 0     | 0 | 3     | 31            |
| 10:30 AM                        | 0                        | 2    | 0     | 0 | 0                        | 0    | 0     | 0 | 0                        | 0    | 0     | 0 | 1                        | 0    | 0     | 0 | 3     | 32            |
| 10:35 AM                        | 0                        | 0    | 0     | 0 | 0                        | 0    | 0     | 0 | 0                        | 0    | 0     | 0 | 1                        | 0    | 0     | 0 | 1     | 29            |
| 10:40 AM                        | 0                        | 0    | 0     | 0 | 0                        | 0    | 1     | 0 | 0                        | 0    | 0     | 0 | 0                        | 0    | 0     | 0 | 1     | 28            |
| 10:45 AM                        | 0                        | 0    | 0     | 0 | 0                        | 0    | 0     | 0 | 0                        | 0    | 0     | 0 | 0                        | 0    | 0     | 0 | 0     | 28            |
| 10:50 AM                        | 1                        | 0    | 1     | 0 | 0                        | 0    | 0     | 0 | 0                        | 0    | 0     | 0 | 1                        | 0    | 0     | 0 | 3     | 28            |
| 10:55 AM                        | 1                        | 0    | 1     | 0 | 0                        | 0    | 0     | 0 | 0                        | 0    | 1     | 0 | 0                        | 0    | 0     | 0 | 3     | 29            |
| 11:00 AM                        | 1                        | 0    | 0     | 0 | 0                        | 0    | 1     | 0 | 0                        | 0    | 0     | 0 | 0                        | 0    | 0     | 0 | 2     | 27            |
| 11:05 AM                        | 2                        | 1    | 0     | 0 | 0                        | 0    | 0     | 0 | 0                        | 0    | 0     | 0 | 0                        | 0    | 0     | 0 | 3     | 26            |
| 11:10 AM                        | 1                        | 0    | 0     | 0 | 0                        | 1    | 0     | 0 | 0                        | 0    | 0     | 1 | 0                        | 0    | 0     | 0 | 3     | 27            |
| 11:15 AM                        | 1                        | 0    | 0     | 0 | 0                        | 0    | 0     | 0 | 0                        | 0    | 1     | 0 | 0                        | 0    | 0     | 0 | 2     | 25            |
| 11:20 AM                        | 0                        | 1    | 1     | 0 | 0                        | 0    | 0     | 0 | 1                        | 0    | 1     | 0 | 0                        | 0    | 0     | 0 | 4     | 28            |
| 11:25 AM                        | 0                        | 0    | 0     | 0 | 0                        | 0    | 0     | 0 | 0                        | 0    | 1     | 0 | 1                        | 0    | 1     | 0 | 3     | 28            |
| 11:30 AM                        | 0                        | 0    | 0     | 0 | 0                        | 0    | 0     | 0 | 0                        | 0    | 0     | 0 | 0                        | 0    | 0     | 0 | 0     | 25            |
| 11:35 AM                        | 0                        | 0    | 0     | 0 | 0                        | 0    | 0     | 0 | 1                        | 0    | 0     | 0 | 0                        | 0    | 0     | 0 | 1     | 25            |
| 11:40 AM                        | 1                        | 0    | 0     | 0 | 0                        | 0    | 0     | 0 | 0                        | 0    | 2     | 0 | 0                        | 0    | 0     | 0 | 3     | 27            |
| 11:45 AM                        | 1                        | 1    | 0     | 0 | 0                        | 0    | 0     | 0 | 0                        | 0    | 2     | 0 | 0                        | 0    | 0     | 0 | 4     | 31            |
| 11:50 AM                        | 0                        | 0    | 0     | 0 | 0                        | 0    | 0     | 0 | 0                        | 0    | 0     | 0 | 1                        | 0    | 0     | 0 | 1     | 29            |
| 11:55 AM                        | 2                        | 0    | 0     | 0 | 0                        | 1    | 0     | 0 | 0                        | 0    | 2     | 0 | 0                        | 0    | 0     | 0 | 5     | 31            |
| 12:00 PM                        | 1                        | 0    | 0     | 0 | 0                        | 0    | 0     | 0 | 1                        | 0    | 1     | 0 | 0                        | 0    | 0     | 0 | 3     | 32            |
| 12:05 PM                        | 1                        | 0    | 0     | 0 | 0                        | 0    | 0     | 0 | 0                        | 0    | 1     | 0 | 0                        | 0    | 0     | 0 | 2     | 31            |
| 12:10 PM                        | 1                        | 0    | 0     | 0 | 0                        | 0    | 0     | 0 | 0                        | 0    | 0     | 0 | 0                        | 0    | 0     | 0 | 1     | 29            |
| 12:15 PM                        | 0                        | 1    | 0     | 0 | 0                        | 0    | 0     | 0 | 0                        | 0    | 1     | 0 | 0                        | 0    | 0     | 0 | 2     | 29            |
| 12:20 PM                        | 1                        | 0    | 1     | 0 | 0                        | 0    | 0     | 0 | 0                        | 0    | 1     | 0 | 0                        | 0    | 0     | 0 | 3     | 28            |
| 12:25 PM                        | 0                        | 0    | 0     | 0 | 0                        | 0    | 0     | 0 | 0                        | 0    | 1     | 0 | 0                        | 0    | 0     | 0 | 1     | 26            |
| 12:30 PM                        | 0                        | 0    | 0     | 0 | 0                        | 1    | 0     | 0 | 1                        | 0    | 1     | 0 | 0                        | 0    | 0     | 0 | 3     | 29            |
| 12:35 PM                        | 0                        | 0    | 0     | 0 | 0                        | 0    | 0     | 0 | 0                        | 0    | 1     | 0 | 0                        | 0    | 0     | 0 | 1     | 29            |
| 12:40 PM                        | 0                        | 0    | 0     | 0 | 0                        | 0    | 0     | 0 | 0                        | 0    | 0     | 0 | 1                        | 0    | 0     | 0 | 1     | 27            |
| 12:45 PM                        | 0                        | 1    | 0     | 0 | 0                        | 0    | 0     | 0 | 0                        | 0    | 0     | 0 | 0                        | 0    | 0     | 0 | 1     | 24            |
| 12:50 PM                        | 0                        | 0    | 0     | 0 | 0                        | 1    | 0     | 0 | 0                        | 0    | 0     | 0 | 1                        | 0    | 0     | 0 | 2     | 25            |
| 12:55 PM                        | 0                        | 0    | 0     | 0 | 0                        | 0    | 0     | 0 | 0                        | 0    | 0     | 0 | 1                        | 0    | 0     | 0 | 1     | 21            |
| 1:00 PM                         | 2                        | 0    | 0     | 0 | 0                        | 0    | 0     | 0 | 0                        | 0    | 1     | 0 | 0                        | 0    | 0     | 0 | 3     | 21            |
| 1:05 PM                         | 0                        | 1    | 0     | 0 | 0                        | 0    | 0     | 0 | 0                        | 0    | 0     | 0 | 0                        | 0    | 0     | 0 | 1     | 20            |
| 1:10 PM                         | 0                        | 0    | 0     | 0 | 0                        | 0    | 0     | 0 | 0                        | 0    | 2     | 0 | 0                        | 0    | 0     | 0 | 2     | 21            |
| 1:15 PM                         | 0                        | 0    | 1     | 0 | 1                        | 0    | 0     | 0 | 0                        | 0    | 1     | 0 | 0                        | 0    | 0     | 0 | 3     | 22            |
| 1:20 PM                         | 1                        | 0    | 0     | 0 | 0                        | 0    | 0     | 0 | 0                        | 0    | 2     | 0 | 0                        | 1    | 0     | 0 | 4     | 23            |
| 1:25 PM                         | 0                        | 0    | 0     | 0 | 0                        | 0    | 0     | 0 | 0                        | 0    | 0     | 0 | 1                        | 0    | 0     | 0 | 1     | 23            |
| 1:30 PM                         | 1                        | 1    | 0     | 0 | 0                        | 0    | 0     | 0 | 0                        | 0    | 4     | 0 | 0                        | 0    | 0     | 0 | 6     | 26            |
| 1:35 PM                         | 1                        | 0    | 0     | 0 | 0                        | 0    | 0     | 0 | 0                        | 1    | 1     | 0 | 0                        | 0    | 1     | 0 | 4     | 29            |
| 1:40 PM                         | 0                        | 0    | 0     | 0 | 1                        | 0    | 0     | 0 | 0                        | 0    | 0     | 0 | 0                        | 0    | 0     | 0 | 1     | 29            |
| 1:45 PM                         | 1                        | 0    | 0     | 0 | 0                        | 1    | 0     | 0 | 0                        | 0    | 0     | 0 | 0                        | 0    | 0     | 0 | 2     | 30            |
| 1:50 PM                         | 0                        | 0    | 0     | 0 | 1                        | 0    | 0     | 0 | 0                        | 0    | 0     | 0 | 0                        | 1    | 0     | 0 | 2     | 30            |
| 1:55 PM                         | 0                        | 2    | 0     | 0 | 0                        | 0    | 0     | 0 | 0                        | 0    | 1     | 0 | 0                        | 0    | 0     | 0 | 3     | 32            |
| 2:00 PM                         | 1                        | 1    | 0     | 0 | 0                        | 1    | 0     | 0 | 0                        | 0    | 2     | 0 | 0                        | 0    | 0     | 0 | 5     | 34            |
| 2:05 PM                         | 2                        | 0    | 0     | 0 | 0                        | 0    | 1     | 0 | 0                        | 0    | 0     | 0 | 0                        | 0    | 0     | 0 | 3     | 36            |
| 2:10 PM                         | 0                        | 1    | 0     | 0 | 0                        | 0    | 0     | 0 | 0                        | 0    | 0     | 0 | 0                        | 0    | 0     | 0 | 1     | 35            |
| 2:15 PM                         | 0                        | 0    | 0     | 0 | 0                        | 0    | 0     | 0 | 0                        | 0    | 1     | 0 | 0                        | 0    | 0     | 0 | 1     | 33            |
| 2:20 PM                         | 0                        | 0    | 0     | 0 | 0                        | 0    | 1     | 0 | 0                        | 1    | 0     | 1 | 0                        | 0    | 0     | 0 | 4     | 33            |
| 2:25 PM                         | 0                        | 0    | 0     | 0 | 0                        | 1    | 0     | 0 | 0                        | 0    | 1     | 0 | 0                        | 0    | 0     | 0 | 2     | 34            |
| 2:30 PM                         | 0                        | 0    | 1     | 0 | 0                        | 0    | 0     | 0 | 0                        | 0    | 0     | 0 | 0                        | 0    | 1     | 0 | 2     | 30            |
| 2:35 PM                         | 0                        | 0    | 0     | 0 | 1                        | 0    | 0     | 0 | 0                        | 0    | 0     | 0 | 0                        | 0    | 0     | 0 | 1     | 27            |
| 2:40 PM                         | 3                        | 0    | 0     | 0 | 0                        | 0    | 0     | 0 | 0                        | 0    | 1     | 0 | 0                        | 0    | 0     | 0 | 4     | 30            |
| 2:45 PM                         | 0                        | 0    | 1     | 0 | 0                        | 1    | 1     | 0 | 1                        | 0    | 3     | 0 | 0                        | 0    | 0     | 0 | 7     | 35            |
| 2:50 PM                         | 0                        | 1    | 0     | 0 | 0                        | 1    | 0     | 0 | 0                        | 0    | 0     | 0 | 0                        | 0    | 0     | 0 | 2     | 35            |
| 2:55 PM                         | 2                        | 1    | 1     | 0 | 0                        | 0    | 0     | 0 | 0                        | 0    | 1     | 0 | 0                        | 0    | 0     | 0 | 5     | 37            |
| 3:00 PM                         | 0                        | 0    | 0     | 0 | 0                        | 0    | 0     | 0 | 0                        | 0    | 0     | 0 | 1                        | 0    | 0     | 0 | 1     | 33            |
| 3:05 PM                         | 1                        | 0    | 0     | 0 | 0                        | 0    | 0     | 0 | 0                        | 0    | 1     | 0 | 1                        | 0    | 0     | 0 | 3     | 33            |
| 3:10 PM                         | 4                        | 0    | 2     | 0 | 0                        | 1    | 0     | 0 | 0                        | 0    | 1     | 0 | 0                        | 0    | 0     | 0 | 8     | 40            |
| 3:15 PM                         | 0                        | 0    | 0     | 0 | 0                        | 0    | 0     | 0 | 0                        | 0    | 1     | 0 | 0                        | 0    | 0     | 0 | 1     | 40            |
| 3:20 PM                         | 1                        | 0    | 0     | 0 | 0                        | 0    | 0     | 0 | 0                        | 0    | 1     | 0 | 0                        | 0    | 0     | 0 | 2     | 38            |
| 3:25 PM                         | 0                        | 0    | 0     | 0 | 0                        | 1    | 0     | 0 | 0                        | 0    | 0     | 0 | 0                        | 0    | 0     | 0 | 1     | 37            |
| 3:30 PM                         | 1                        | 0    | 0     | 0 | 0                        | 0    | 1     | 0 | 0                        | 0    | 0     | 0 | 0                        | 0    | 0     | 0 | 2     | 37            |
| 3:35 PM                         | 0                        | 0    | 0     | 0 | 0                        | 0    | 0     | 0 | 0                        | 0    | 1     | 0 | 0                        | 0    | 1     | 0 | 2     | 38            |
| 3:40 PM                         | 0                        | 0    | 0     | 0 | 0                        | 0    | 0     | 0 | 0                        | 0    | 0     | 0 | 1                        | 0    | 0     | 0 | 1     | 35            |
| 3:45 PM                         | 0                        | 1    | 1     | 0 | 0                        | 0    | 0     | 0 | 0                        | 0    | 0     | 0 | 0                        | 0    | 0     | 0 | 2     | 30            |
| 3:50 PM                         | 1                        | 0    | 0     | 0 | 0                        | 0    | 0     | 0 | 0                        | 0    | 2     | 0 | 1                        | 0    | 0     | 0 | 4     | 32            |
| 3:55 PM                         | 0                        | 0    | 0     | 0 | 0                        | 0    | 0     | 0 | 0                        | 0    | 1     | 0 | 0                        | 0    | 0     | 0 | 1     | 28            |
| 4:00 PM                         | 0                        | 0    | 1     | 0 | 0                        | 0    | 0     | 0 | 0                        | 0    | 2     | 0 | 1                        | 0    | 0     | 0 | 4     | 31            |
| 4:05 PM                         | 1                        | 0    | 0     | 0 | 0                        | 1    | 0     | 0 | 0                        | 0    | 0     | 0 | 0                        | 0    | 0     | 0 | 2     | 30            |
| 4:10 PM                         | 1                        | 0    | 0     | 0 | 0                        | 0    | 0     | 0 | 0                        | 0    | 0     | 0 | 0                        | 0    | 0     | 0 | 1     | 23            |
| 4:15 PM                         | 1                        | 0    | 0     | 0 | 0                        | 1    | 0     | 0 | 0                        | 0    | 0     | 0 | 0                        | 0    | 0     | 0 | 2     | 24            |
| 4:20 PM                         | 1                        | 0    | 0     | 0 | 0                        | 0    | 0     | 0 | 0                        | 0    | 0     | 0 | 0                        | 0    | 0     | 0 | 1     | 23            |
| 4:25 PM                         | 1                        | 2    | 1     | 0 | 0                        | 0    | 0     | 0 | 0                        | 0    | 1     | 0 | 0                        | 0    | 0     | 0 | 5     | 27            |

**Attachment B**

| 5-Min Count Period Beginning At | Overhill Dr (Northbound) |      |       |   | Overhill Dr (Southbound) |      |       |   | Deerhaven Dr (Eastbound) |      |       |   | Deerhaven Dr (Westbound) |      |       |   | Total | Hourly Totals |
|---------------------------------|--------------------------|------|-------|---|--------------------------|------|-------|---|--------------------------|------|-------|---|--------------------------|------|-------|---|-------|---------------|
|                                 | Left                     | Thru | Right | U | Left                     | Thru | Right | U | Left                     | Thru | Right | U | Left                     | Thru | Right | U |       |               |
| 4:30 PM                         | 2                        | 0    | 0     | 0 | 0                        | 0    | 0     | 0 | 0                        | 0    | 1     | 0 | 0                        | 0    | 0     | 0 | 3     | 28            |
| 4:35 PM                         | 0                        | 0    | 0     | 0 | 0                        | 0    | 0     | 0 | 0                        | 0    | 0     | 0 | 0                        | 0    | 0     | 0 | 0     | 26            |
| 4:40 PM                         | 0                        | 0    | 0     | 0 | 0                        | 0    | 1     | 0 | 0                        | 0    | 4     | 0 | 0                        | 0    | 0     | 0 | 5     | 30            |
| 4:45 PM                         | 0                        | 0    | 0     | 0 | 0                        | 0    | 0     | 0 | 0                        | 0    | 1     | 0 | 0                        | 0    | 0     | 0 | 1     | 29            |
| 4:50 PM                         | 0                        | 0    | 0     | 0 | 0                        | 0    | 0     | 0 | 0                        | 0    | 1     | 0 | 0                        | 0    | 0     | 0 | 1     | 26            |
| 4:55 PM                         | 1                        | 0    | 1     | 0 | 0                        | 0    | 0     | 0 | 0                        | 0    | 0     | 0 | 0                        | 0    | 0     | 0 | 2     | 27            |
| 5:00 PM                         | 1                        | 0    | 0     | 0 | 0                        | 0    | 0     | 0 | 0                        | 0    | 0     | 0 | 0                        | 0    | 0     | 0 | 1     | 24            |
| 5:05 PM                         | 0                        | 0    | 0     | 0 | 0                        | 0    | 0     | 0 | 0                        | 0    | 1     | 0 | 0                        | 0    | 0     | 0 | 1     | 23            |
| 5:10 PM                         | 0                        | 0    | 0     | 0 | 1                        | 1    | 0     | 0 | 0                        | 0    | 1     | 0 | 0                        | 0    | 0     | 0 | 3     | 25            |
| 5:15 PM                         | 1                        | 0    | 0     | 0 | 0                        | 0    | 0     | 0 | 0                        | 0    | 0     | 0 | 1                        | 1    | 0     | 0 | 3     | 26            |
| 5:20 PM                         | 1                        | 0    | 0     | 0 | 0                        | 0    | 0     | 0 | 0                        | 0    | 0     | 0 | 0                        | 0    | 0     | 0 | 1     | 26            |
| 5:25 PM                         | 0                        | 1    | 0     | 0 | 0                        | 0    | 0     | 0 | 0                        | 0    | 3     | 0 | 0                        | 0    | 0     | 0 | 4     | 25            |
| 5:30 PM                         | 0                        | 0    | 0     | 0 | 0                        | 0    | 0     | 0 | 0                        | 0    | 0     | 0 | 0                        | 0    | 0     | 0 | 0     | 22            |
| 5:35 PM                         | 0                        | 0    | 0     | 0 | 0                        | 1    | 0     | 0 | 0                        | 0    | 0     | 0 | 0                        | 0    | 0     | 0 | 1     | 23            |
| 5:40 PM                         | 0                        | 0    | 1     | 0 | 0                        | 0    | 0     | 0 | 0                        | 0    | 0     | 0 | 0                        | 0    | 0     | 0 | 1     | 19            |
| 5:45 PM                         | 0                        | 0    | 0     | 0 | 0                        | 0    | 0     | 0 | 0                        | 0    | 0     | 0 | 0                        | 0    | 0     | 0 | 0     | 18            |
| 5:50 PM                         | 0                        | 0    | 0     | 0 | 0                        | 0    | 0     | 0 | 0                        | 0    | 0     | 0 | 0                        | 0    | 0     | 0 | 0     | 17            |
| 5:55 PM                         | 0                        | 0    | 1     | 0 | 0                        | 0    | 0     | 0 | 0                        | 0    | 0     | 0 | 0                        | 0    | 0     | 0 | 1     | 16            |
| 6:00 PM                         | 1                        | 0    | 0     | 0 | 0                        | 0    | 0     | 0 | 0                        | 0    | 0     | 0 | 0                        | 1    | 0     | 0 | 2     | 17            |
| 6:05 PM                         | 0                        | 1    | 0     | 0 | 0                        | 0    | 0     | 0 | 0                        | 1    | 0     | 0 | 0                        | 0    | 0     | 0 | 2     | 18            |
| 6:10 PM                         | 0                        | 0    | 0     | 0 | 0                        | 0    | 0     | 0 | 0                        | 0    | 0     | 0 | 0                        | 0    | 0     | 0 | 0     | 15            |
| 6:15 PM                         | 0                        | 0    | 0     | 0 | 0                        | 0    | 0     | 0 | 0                        | 0    | 0     | 0 | 0                        | 0    | 0     | 0 | 0     | 12            |
| 6:20 PM                         | 0                        | 1    | 0     | 0 | 0                        | 0    | 0     | 0 | 0                        | 0    | 1     | 0 | 0                        | 0    | 0     | 0 | 2     | 13            |
| 6:25 PM                         | 0                        | 0    | 0     | 0 | 0                        | 0    | 0     | 0 | 0                        | 0    | 1     | 0 | 0                        | 0    | 0     | 0 | 1     | 10            |
| 6:30 PM                         | 0                        | 0    | 0     | 0 | 0                        | 0    | 0     | 0 | 0                        | 0    | 1     | 0 | 0                        | 0    | 0     | 0 | 1     | 11            |
| 6:35 PM                         | 0                        | 0    | 0     | 0 | 0                        | 0    | 0     | 0 | 0                        | 0    | 1     | 0 | 0                        | 0    | 0     | 0 | 1     | 11            |
| 6:40 PM                         | 0                        | 0    | 0     | 0 | 0                        | 0    | 0     | 0 | 0                        | 0    | 0     | 0 | 0                        | 0    | 0     | 0 | 0     | 10            |
| 6:45 PM                         | 0                        | 0    | 0     | 0 | 0                        | 1    | 0     | 0 | 0                        | 0    | 0     | 1 | 0                        | 0    | 0     | 0 | 2     | 12            |
| 6:50 PM                         | 0                        | 0    | 0     | 0 | 0                        | 0    | 0     | 0 | 0                        | 0    | 1     | 0 | 0                        | 0    | 0     | 0 | 1     | 13            |
| 6:55 PM                         | 0                        | 0    | 0     | 0 | 0                        | 0    | 0     | 0 | 0                        | 0    | 0     | 0 | 0                        | 0    | 0     | 0 | 0     | 12            |
| 7:00 PM                         | 0                        | 0    | 0     | 0 | 0                        | 0    | 0     | 0 | 0                        | 0    | 0     | 0 | 0                        | 0    | 0     | 0 | 0     | 10            |
| 7:05 PM                         | 3                        | 1    | 0     | 0 | 0                        | 0    | 1     | 0 | 0                        | 0    | 0     | 0 | 0                        | 0    | 0     | 0 | 5     | 13            |
| 7:10 PM                         | 0                        | 0    | 0     | 0 | 0                        | 0    | 0     | 0 | 0                        | 0    | 0     | 0 | 0                        | 0    | 0     | 0 | 0     | 13            |
| 7:15 PM                         | 0                        | 0    | 0     | 0 | 0                        | 0    | 0     | 0 | 0                        | 0    | 0     | 0 | 0                        | 0    | 0     | 0 | 0     | 13            |
| 7:20 PM                         | 0                        | 0    | 0     | 0 | 0                        | 0    | 0     | 0 | 0                        | 0    | 0     | 0 | 0                        | 0    | 0     | 0 | 0     | 11            |
| 7:25 PM                         | 0                        | 0    | 0     | 0 | 0                        | 0    | 0     | 0 | 0                        | 0    | 0     | 0 | 0                        | 0    | 0     | 0 | 0     | 10            |
| 7:30 PM                         | 2                        | 0    | 0     | 0 | 0                        | 0    | 0     | 0 | 0                        | 0    | 0     | 0 | 0                        | 0    | 0     | 0 | 2     | 11            |
| 7:35 PM                         | 0                        | 0    | 0     | 0 | 0                        | 0    | 0     | 0 | 0                        | 0    | 0     | 0 | 0                        | 0    | 0     | 0 | 0     | 10            |
| 7:40 PM                         | 1                        | 0    | 2     | 0 | 0                        | 0    | 0     | 0 | 0                        | 0    | 0     | 0 | 0                        | 0    | 0     | 0 | 3     | 13            |
| 7:45 PM                         | 0                        | 0    | 0     | 0 | 0                        | 0    | 0     | 0 | 0                        | 0    | 0     | 0 | 0                        | 0    | 0     | 0 | 0     | 11            |
| 7:50 PM                         | 0                        | 0    | 0     | 0 | 0                        | 0    | 0     | 0 | 0                        | 0    | 0     | 0 | 0                        | 0    | 0     | 0 | 0     | 10            |
| 7:55 PM                         | 0                        | 0    | 0     | 0 | 0                        | 0    | 0     | 0 | 0                        | 0    | 0     | 0 | 0                        | 0    | 0     | 0 | 0     | 10            |
| 8:00 PM                         | 1                        | 0    | 0     | 0 | 0                        | 0    | 0     | 0 | 0                        | 0    | 0     | 0 | 0                        | 0    | 0     | 0 | 1     | 11            |
| 8:05 PM                         | 0                        | 0    | 0     | 0 | 0                        | 0    | 0     | 0 | 0                        | 0    | 0     | 0 | 1                        | 0    | 0     | 0 | 1     | 7             |
| 8:10 PM                         | 0                        | 0    | 0     | 0 | 0                        | 0    | 0     | 0 | 0                        | 0    | 0     | 0 | 0                        | 0    | 0     | 0 | 0     | 7             |
| 8:15 PM                         | 1                        | 0    | 0     | 0 | 0                        | 0    | 0     | 0 | 0                        | 0    | 0     | 0 | 0                        | 0    | 0     | 0 | 1     | 8             |
| 8:20 PM                         | 1                        | 0    | 0     | 0 | 0                        | 0    | 0     | 0 | 0                        | 0    | 1     | 0 | 0                        | 0    | 0     | 0 | 2     | 10            |
| 8:25 PM                         | 1                        | 0    | 0     | 0 | 0                        | 0    | 0     | 0 | 0                        | 0    | 0     | 0 | 0                        | 0    | 0     | 0 | 1     | 11            |
| 8:30 PM                         | 0                        | 0    | 1     | 0 | 0                        | 0    | 0     | 0 | 0                        | 0    | 0     | 0 | 0                        | 0    | 0     | 0 | 1     | 10            |
| 8:35 PM                         | 1                        | 2    | 0     | 0 | 0                        | 0    | 0     | 0 | 0                        | 0    | 0     | 0 | 0                        | 0    | 0     | 0 | 3     | 13            |
| 8:40 PM                         | 0                        | 0    | 0     | 0 | 0                        | 0    | 0     | 0 | 0                        | 0    | 0     | 0 | 0                        | 0    | 0     | 0 | 0     | 10            |
| 8:45 PM                         | 0                        | 0    | 0     | 0 | 0                        | 0    | 0     | 0 | 0                        | 0    | 0     | 0 | 0                        | 0    | 0     | 0 | 0     | 10            |
| 8:50 PM                         | 2                        | 0    | 0     | 0 | 0                        | 0    | 0     | 0 | 0                        | 0    | 0     | 0 | 0                        | 0    | 0     | 0 | 2     | 12            |
| 8:55 PM                         | 0                        | 0    | 0     | 0 | 0                        | 0    | 0     | 0 | 0                        | 0    | 0     | 0 | 0                        | 0    | 0     | 0 | 0     | 12            |
| 9:00 PM                         | 1                        | 0    | 0     | 0 | 0                        | 0    | 0     | 0 | 0                        | 0    | 0     | 0 | 0                        | 0    | 0     | 0 | 1     | 12            |
| 9:05 PM                         | 0                        | 0    | 0     | 0 | 0                        | 0    | 0     | 0 | 0                        | 0    | 0     | 0 | 0                        | 0    | 0     | 0 | 0     | 11            |
| 9:10 PM                         | 0                        | 0    | 0     | 0 | 0                        | 0    | 0     | 0 | 0                        | 0    | 0     | 0 | 0                        | 0    | 0     | 0 | 0     | 11            |
| 9:15 PM                         | 0                        | 0    | 0     | 0 | 0                        | 0    | 0     | 0 | 0                        | 0    | 1     | 0 | 0                        | 0    | 0     | 0 | 1     | 11            |
| 9:20 PM                         | 1                        | 0    | 0     | 0 | 0                        | 0    | 0     | 0 | 0                        | 0    | 0     | 0 | 0                        | 0    | 0     | 0 | 1     | 10            |
| 9:25 PM                         | 0                        | 0    | 0     | 0 | 0                        | 0    | 0     | 0 | 0                        | 0    | 0     | 0 | 0                        | 0    | 0     | 0 | 0     | 9             |
| 9:30 PM                         | 0                        | 0    | 0     | 0 | 0                        | 0    | 0     | 0 | 0                        | 0    | 0     | 0 | 0                        | 0    | 0     | 0 | 0     | 8             |
| 9:35 PM                         | 0                        | 0    | 0     | 0 | 0                        | 0    | 0     | 0 | 0                        | 0    | 0     | 0 | 0                        | 0    | 0     | 0 | 0     | 5             |
| 9:40 PM                         | 0                        | 0    | 0     | 0 | 0                        | 0    | 0     | 0 | 0                        | 0    | 0     | 0 | 0                        | 0    | 0     | 0 | 0     | 5             |
| 9:45 PM                         | 0                        | 1    | 0     | 0 | 0                        | 0    | 0     | 0 | 0                        | 0    | 0     | 0 | 0                        | 0    | 0     | 0 | 1     | 6             |
| 9:50 PM                         | 0                        | 0    | 0     | 0 | 0                        | 0    | 0     | 0 | 0                        | 0    | 0     | 0 | 0                        | 0    | 0     | 0 | 0     | 4             |
| 9:55 PM                         | 0                        | 0    | 0     | 0 | 0                        | 1    | 0     | 0 | 0                        | 0    | 0     | 0 | 0                        | 0    | 0     | 0 | 1     | 5             |
| Peak 15-Min Flowrates           | Northbound               |      |       |   | Southbound               |      |       |   | Eastbound                |      |       |   | Westbound                |      |       |   | Total |               |
|                                 | Left                     | Thru | Right | U | Left                     | Thru | Right | U | Left                     | Thru | Right | U | Left                     | Thru | Right | U |       |               |
| All Vehicles                    | 8                        | 8    | 8     | 0 | 0                        | 8    | 4     | 0 | 4                        | 0    | 16    | 0 | 0                        | 0    | 0     | 0 | 56    |               |
| Heavy Trucks                    | 0                        | 0    | 0     |   | 0                        | 0    | 0     |   | 0                        | 0    | 0     |   | 0                        | 0    | 0     |   | 0     |               |
| Buses                           |                          |      |       |   |                          |      |       |   |                          |      |       |   |                          |      |       |   |       |               |
| Pedestrians                     |                          | 0    |       |   |                          | 0    |       |   |                          | 0    |       |   |                          | 0    |       |   | 0     |               |
| Bicycles                        | 0                        | 0    | 0     |   | 0                        | 0    | 0     |   | 0                        | 0    | 0     |   | 0                        | 0    | 0     |   | 0     |               |
| Scoters                         |                          |      |       |   |                          |      |       |   |                          |      |       |   |                          |      |       |   |       |               |
| <i>Comments:</i>                |                          |      |       |   |                          |      |       |   |                          |      |       |   |                          |      |       |   |       |               |

LOCATION: Cherry Hill Dr -- Coronel Rd  
 CITY/STATE: North Tustin, CA

QC JOB #: 16966435  
 DATE: Thu, Apr 10 2025

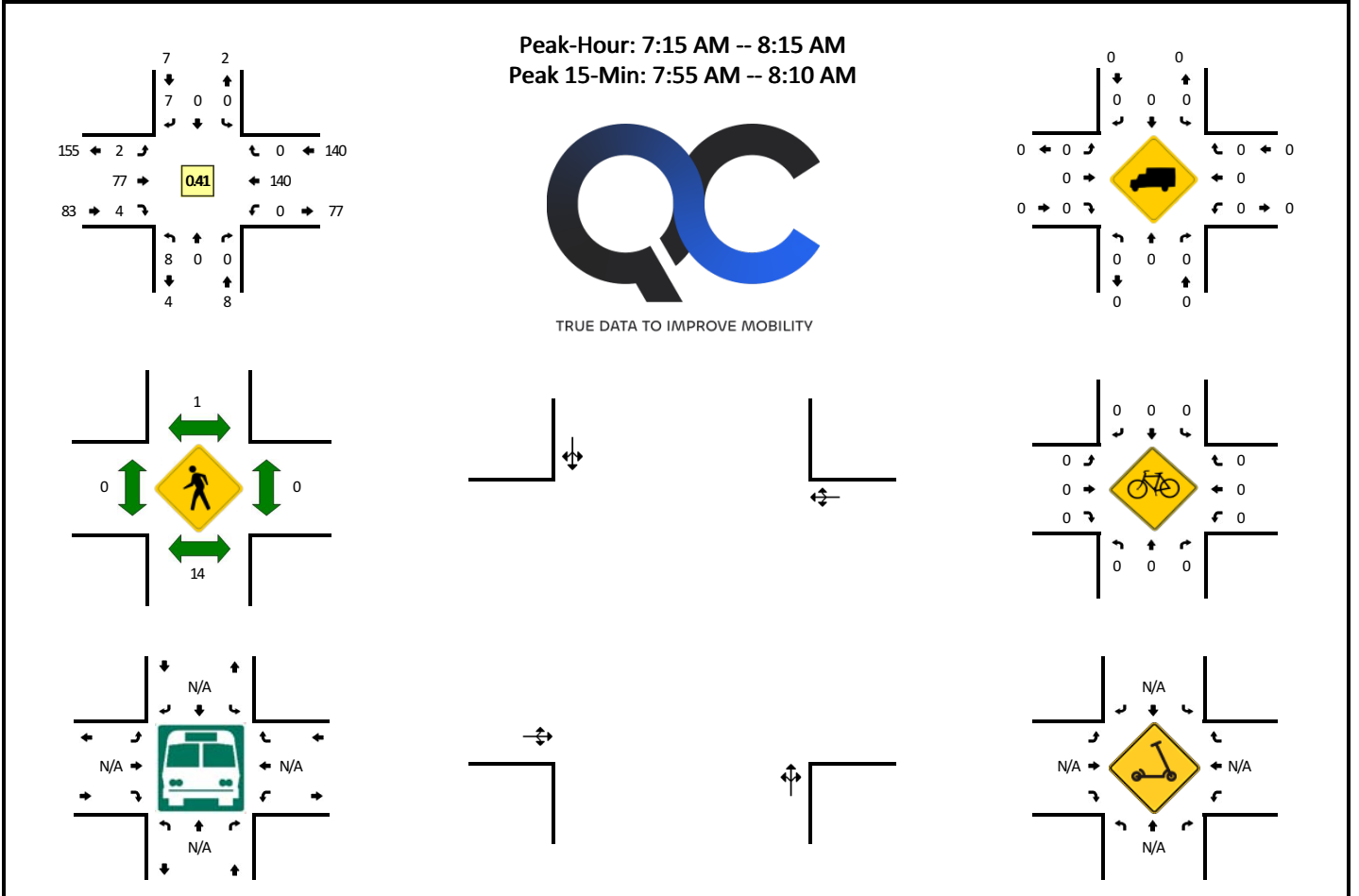

| 5-Min Count Period Beginning At | Cherry Hill Dr (Northbound) |      |       |   | Cherry Hill Dr (Southbound) |      |       |   | Coronel Rd (Eastbound) |      |       |   | Coronel Rd (Westbound) |      |       |   | Total | Hourly Totals |
|---------------------------------|-----------------------------|------|-------|---|-----------------------------|------|-------|---|------------------------|------|-------|---|------------------------|------|-------|---|-------|---------------|
|                                 | Left                        | Thru | Right | U | Left                        | Thru | Right | U | Left                   | Thru | Right | U | Left                   | Thru | Right | U |       |               |
| 6:00 AM                         | 0                           | 0    | 0     | 0 | 0                           | 0    | 0     | 0 | 0                      | 0    | 0     | 1 | 0                      | 0    | 0     | 0 | 1     |               |
| 6:05 AM                         | 0                           | 0    | 0     | 0 | 0                           | 0    | 0     | 0 | 0                      | 0    | 0     | 0 | 0                      | 0    | 0     | 0 | 0     |               |
| 6:10 AM                         | 0                           | 0    | 0     | 0 | 0                           | 0    | 0     | 0 | 0                      | 0    | 0     | 0 | 0                      | 0    | 0     | 0 | 0     |               |
| 6:15 AM                         | 0                           | 0    | 0     | 0 | 0                           | 0    | 0     | 0 | 0                      | 0    | 0     | 0 | 0                      | 1    | 0     | 0 | 1     |               |
| 6:20 AM                         | 0                           | 0    | 0     | 0 | 0                           | 0    | 0     | 0 | 0                      | 0    | 1     | 0 | 0                      | 0    | 0     | 0 | 1     |               |
| 6:25 AM                         | 0                           | 0    | 0     | 0 | 0                           | 0    | 0     | 0 | 0                      | 0    | 0     | 0 | 0                      | 0    | 0     | 0 | 0     |               |
| 6:30 AM                         | 0                           | 0    | 0     | 0 | 0                           | 0    | 0     | 0 | 0                      | 0    | 1     | 0 | 0                      | 0    | 2     | 0 | 3     |               |
| 6:35 AM                         | 0                           | 0    | 1     | 0 | 0                           | 0    | 0     | 0 | 0                      | 0    | 0     | 0 | 0                      | 0    | 0     | 0 | 1     |               |
| 6:40 AM                         | 0                           | 0    | 0     | 0 | 0                           | 0    | 0     | 0 | 0                      | 0    | 0     | 0 | 0                      | 0    | 0     | 0 | 0     |               |
| 6:45 AM                         | 0                           | 0    | 0     | 0 | 0                           | 0    | 0     | 0 | 0                      | 0    | 1     | 0 | 0                      | 0    | 0     | 0 | 1     |               |
| 6:50 AM                         | 0                           | 0    | 0     | 0 | 0                           | 0    | 0     | 0 | 0                      | 0    | 0     | 1 | 0                      | 0    | 0     | 0 | 1     |               |
| 6:55 AM                         | 1                           | 0    | 0     | 0 | 0                           | 0    | 0     | 0 | 0                      | 0    | 0     | 1 | 0                      | 0    | 0     | 0 | 2     | 11            |
| 7:00 AM                         | 0                           | 0    | 0     | 0 | 1                           | 0    | 1     | 0 | 1                      | 1    | 0     | 0 | 0                      | 0    | 0     | 0 | 4     | 14            |
| 7:05 AM                         | 0                           | 0    | 0     | 0 | 0                           | 0    | 1     | 0 | 0                      | 0    | 0     | 0 | 0                      | 2    | 0     | 0 | 3     | 17            |
| 7:10 AM                         | 0                           | 0    | 0     | 0 | 0                           | 0    | 0     | 0 | 0                      | 0    | 0     | 0 | 0                      | 0    | 0     | 0 | 0     | 17            |
| 7:15 AM                         | 2                           | 0    | 0     | 0 | 0                           | 0    | 0     | 0 | 0                      | 3    | 1     | 0 | 0                      | 1    | 0     | 0 | 7     | 23            |
| 7:20 AM                         | 0                           | 0    | 0     | 0 | 0                           | 0    | 0     | 0 | 0                      | 1    | 0     | 0 | 0                      | 3    | 0     | 0 | 4     | 26            |
| 7:25 AM                         | 1                           | 0    | 0     | 0 | 0                           | 0    | 1     | 0 | 0                      | 0    | 0     | 0 | 0                      | 2    | 0     | 0 | 4     | 30            |
| 7:30 AM                         | 1                           | 0    | 0     | 0 | 0                           | 0    | 1     | 0 | 0                      | 0    | 0     | 0 | 0                      | 2    | 0     | 0 | 4     | 31            |
| 7:35 AM                         | 0                           | 0    | 0     | 0 | 0                           | 0    | 2     | 0 | 1                      | 1    | 0     | 0 | 0                      | 3    | 0     | 0 | 7     | 37            |
| 7:40 AM                         | 1                           | 0    | 0     | 0 | 0                           | 0    | 2     | 0 | 0                      | 2    | 1     | 0 | 0                      | 4    | 0     | 0 | 10    | 47            |
| 7:45 AM                         | 0                           | 0    | 0     | 0 | 0                           | 0    | 0     | 0 | 0                      | 2    | 0     | 0 | 0                      | 10   | 0     | 0 | 12    | 58            |
| 7:50 AM                         | 0                           | 0    | 0     | 0 | 0                           | 0    | 0     | 0 | 1                      | 2    | 0     | 0 | 0                      | 25   | 0     | 0 | 28    | 85            |
| 7:55 AM                         | 2                           | 0    | 0     | 0 | 0                           | 0    | 0     | 0 | 0                      | 15   | 1     | 0 | 0                      | 41   | 0     | 0 | 59    | 142           |
| 8:00 AM                         | 1                           | 0    | 0     | 0 | 0                           | 0    | 0     | 0 | 0                      | 21   | 0     | 0 | 0                      | 29   | 0     | 0 | 51    | 189           |
| 8:05 AM                         | 0                           | 0    | 0     | 0 | 0                           | 0    | 1     | 0 | 0                      | 18   | 1     | 0 | 0                      | 15   | 0     | 0 | 35    | 221           |
| 8:10 AM                         | 0                           | 0    | 0     | 0 | 0                           | 0    | 0     | 0 | 0                      | 12   | 0     | 0 | 0                      | 5    | 0     | 0 | 17    | 238           |
| 8:15 AM                         | 0                           | 0    | 0     | 0 | 0                           | 0    | 0     | 0 | 0                      | 2    | 0     | 0 | 0                      | 0    | 0     | 0 | 2     | 233           |
| 8:20 AM                         | 0                           | 0    | 0     | 0 | 0                           | 0    | 0     | 0 | 1                      | 0    | 0     | 0 | 0                      | 3    | 0     | 0 | 4     | 233           |
| 8:25 AM                         | 1                           | 0    | 1     | 0 | 0                           | 0    | 1     | 0 | 0                      | 1    | 0     | 0 | 0                      | 1    | 1     | 0 | 6     | 235           |
| 8:30 AM                         | 0                           | 0    | 0     | 0 | 0                           | 0    | 0     | 0 | 0                      | 0    | 0     | 0 | 0                      | 1    | 0     | 0 | 1     | 232           |
| 8:35 AM                         | 1                           | 0    | 0     | 0 | 1                           | 0    | 0     | 0 | 0                      | 1    | 0     | 0 | 0                      | 0    | 0     | 0 | 3     | 228           |
| 8:40 AM                         | 0                           | 0    | 0     | 0 | 0                           | 0    | 0     | 0 | 0                      | 1    | 0     | 0 | 0                      | 1    | 0     | 0 | 2     | 220           |
| 8:45 AM                         | 0                           | 0    | 0     | 0 | 0                           | 0    | 0     | 0 | 0                      | 1    | 0     | 0 | 0                      | 1    | 0     | 0 | 2     | 210           |
| 8:50 AM                         | 1                           | 0    | 0     | 0 | 0                           | 0    | 0     | 0 | 0                      | 0    | 0     | 0 | 0                      | 1    | 0     | 0 | 2     | 184           |
| 8:55 AM                         | 1                           | 0    | 0     | 0 | 0                           | 0    | 0     | 0 | 0                      | 0    | 1     | 0 | 0                      | 0    | 0     | 0 | 2     | 127           |
| 9:00 AM                         | 1                           | 0    | 0     | 0 | 0                           | 0    | 0     | 0 | 0                      | 0    | 0     | 0 | 1                      | 0    | 1     | 0 | 3     | 79            |
| 9:05 AM                         | 0                           | 0    | 0     | 0 | 1                           | 0    | 0     | 0 | 0                      | 0    | 0     | 0 | 0                      | 1    | 0     | 0 | 2     | 46            |

| 5-Min Count<br>Period<br>Beginning At | Cherry Hill Dr<br>(Northbound) |      |       |   | Cherry Hill Dr<br>(Southbound) |      |       |   | Coronel Rd<br>(Eastbound) |      |       |   | Coronel Rd<br>(Westbound) |      |       |   | Total | Hourly<br>Totals |
|---------------------------------------|--------------------------------|------|-------|---|--------------------------------|------|-------|---|---------------------------|------|-------|---|---------------------------|------|-------|---|-------|------------------|
|                                       | Left                           | Thru | Right | U | Left                           | Thru | Right | U | Left                      | Thru | Right | U | Left                      | Thru | Right | U |       |                  |
| 9:10 AM                               | 0                              | 0    | 0     | 0 | 0                              | 0    | 0     | 0 | 0                         | 0    | 0     | 0 | 0                         | 1    | 0     | 0 | 1     | 30               |
| 9:15 AM                               | 0                              | 0    | 0     | 0 | 0                              | 0    | 0     | 0 | 0                         | 1    | 1     | 0 | 0                         | 0    | 1     | 0 | 0     | 31               |
| 9:20 AM                               | 0                              | 0    | 0     | 0 | 0                              | 0    | 2     | 0 | 0                         | 0    | 0     | 0 | 0                         | 1    | 0     | 0 | 3     | 30               |
| 9:25 AM                               | 0                              | 0    | 1     | 0 | 0                              | 0    | 0     | 0 | 0                         | 0    | 1     | 0 | 0                         | 1    | 0     | 0 | 3     | 27               |
| 9:30 AM                               | 1                              | 0    | 0     | 0 | 0                              | 0    | 2     | 0 | 0                         | 0    | 0     | 0 | 0                         | 0    | 0     | 0 | 3     | 29               |
| 9:35 AM                               | 0                              | 0    | 0     | 0 | 0                              | 0    | 0     | 0 | 0                         | 1    | 1     | 0 | 0                         | 2    | 0     | 0 | 4     | 30               |
| 9:40 AM                               | 0                              | 0    | 0     | 0 | 0                              | 0    | 1     | 0 | 0                         | 0    | 0     | 0 | 0                         | 0    | 0     | 0 | 1     | 29               |
| 9:45 AM                               | 0                              | 0    | 0     | 0 | 0                              | 0    | 0     | 0 | 0                         | 2    | 0     | 0 | 0                         | 1    | 0     | 0 | 3     | 30               |
| 9:50 AM                               | 1                              | 0    | 0     | 0 | 0                              | 0    | 1     | 0 | 1                         | 0    | 0     | 0 | 0                         | 1    | 0     | 0 | 4     | 32               |
| 9:55 AM                               | 1                              | 0    | 0     | 0 | 0                              | 0    | 0     | 0 | 0                         | 2    | 0     | 0 | 0                         | 2    | 0     | 0 | 5     | 35               |
| 10:00 AM                              | 0                              | 0    | 0     | 0 | 0                              | 0    | 0     | 0 | 0                         | 0    | 0     | 0 | 0                         | 0    | 0     | 0 | 0     | 32               |
| 10:05 AM                              | 0                              | 0    | 0     | 0 | 0                              | 0    | 1     | 0 | 0                         | 0    | 0     | 0 | 0                         | 0    | 0     | 0 | 1     | 31               |
| 10:10 AM                              | 0                              | 0    | 0     | 0 | 0                              | 0    | 0     | 0 | 1                         | 2    | 1     | 0 | 0                         | 2    | 0     | 0 | 6     | 36               |
| 10:15 AM                              | 1                              | 0    | 0     | 0 | 0                              | 0    | 0     | 0 | 0                         | 0    | 0     | 0 | 0                         | 0    | 0     | 0 | 1     | 34               |
| 10:20 AM                              | 0                              | 0    | 0     | 0 | 0                              | 0    | 0     | 0 | 1                         | 0    | 1     | 0 | 0                         | 0    | 0     | 0 | 2     | 33               |
| 10:25 AM                              | 2                              | 0    | 0     | 0 | 0                              | 0    | 0     | 0 | 0                         | 1    | 1     | 0 | 1                         | 0    | 0     | 0 | 5     | 35               |
| 10:30 AM                              | 0                              | 0    | 0     | 0 | 0                              | 0    | 1     | 0 | 0                         | 1    | 0     | 0 | 0                         | 1    | 0     | 0 | 3     | 35               |
| 10:35 AM                              | 1                              | 0    | 0     | 0 | 0                              | 0    | 0     | 0 | 0                         | 1    | 0     | 0 | 0                         | 1    | 0     | 0 | 3     | 34               |
| 10:40 AM                              | 0                              | 0    | 0     | 0 | 0                              | 0    | 0     | 0 | 1                         | 0    | 0     | 0 | 0                         | 1    | 0     | 0 | 2     | 35               |
| 10:45 AM                              | 0                              | 0    | 0     | 0 | 0                              | 0    | 0     | 0 | 0                         | 0    | 0     | 0 | 0                         | 0    | 0     | 0 | 0     | 32               |
| 10:50 AM                              | 0                              | 0    | 0     | 0 | 0                              | 0    | 0     | 0 | 0                         | 2    | 1     | 0 | 0                         | 1    | 0     | 0 | 4     | 32               |
| 10:55 AM                              | 0                              | 0    | 0     | 0 | 0                              | 0    | 0     | 0 | 0                         | 1    | 0     | 0 | 0                         | 2    | 0     | 0 | 3     | 30               |
| 11:00 AM                              | 0                              | 0    | 0     | 0 | 0                              | 0    | 0     | 0 | 0                         | 0    | 0     | 0 | 0                         | 0    | 0     | 0 | 0     | 30               |
| 11:05 AM                              | 1                              | 0    | 0     | 0 | 0                              | 0    | 0     | 0 | 0                         | 3    | 0     | 0 | 0                         | 0    | 0     | 0 | 4     | 33               |
| 11:10 AM                              | 0                              | 0    | 0     | 0 | 0                              | 0    | 0     | 0 | 0                         | 0    | 0     | 0 | 0                         | 1    | 0     | 0 | 1     | 28               |
| 11:15 AM                              | 0                              | 0    | 0     | 0 | 0                              | 0    | 0     | 0 | 0                         | 0    | 0     | 0 | 0                         | 0    | 0     | 0 | 0     | 27               |
| 11:20 AM                              | 0                              | 0    | 0     | 0 | 0                              | 0    | 0     | 0 | 1                         | 0    | 1     | 0 | 0                         | 2    | 1     | 0 | 5     | 30               |
| 11:25 AM                              | 0                              | 0    | 0     | 0 | 0                              | 0    | 0     | 0 | 0                         | 1    | 1     | 0 | 0                         | 1    | 0     | 0 | 3     | 28               |
| 11:30 AM                              | 1                              | 0    | 0     | 0 | 0                              | 0    | 3     | 0 | 1                         | 0    | 1     | 0 | 0                         | 1    | 0     | 0 | 7     | 32               |
| 11:35 AM                              | 1                              | 0    | 1     | 0 | 0                              | 0    | 0     | 0 | 0                         | 1    | 0     | 0 | 0                         | 3    | 0     | 0 | 6     | 35               |
| 11:40 AM                              | 3                              | 0    | 0     | 0 | 0                              | 0    | 1     | 0 | 0                         | 0    | 1     | 0 | 0                         | 1    | 0     | 0 | 6     | 39               |
| 11:45 AM                              | 0                              | 0    | 0     | 0 | 0                              | 0    | 0     | 0 | 0                         | 0    | 0     | 0 | 0                         | 0    | 0     | 0 | 0     | 39               |
| 11:50 AM                              | 0                              | 0    | 0     | 0 | 0                              | 0    | 0     | 0 | 0                         | 1    | 0     | 0 | 0                         | 1    | 0     | 0 | 2     | 37               |
| 11:55 AM                              | 0                              | 0    | 0     | 0 | 0                              | 0    | 0     | 0 | 0                         | 0    | 2     | 0 | 0                         | 3    | 0     | 0 | 5     | 39               |
| 12:00 PM                              | 1                              | 0    | 0     | 0 | 1                              | 0    | 0     | 0 | 2                         | 0    | 0     | 0 | 0                         | 2    | 0     | 0 | 6     | 45               |
| 12:05 PM                              | 0                              | 0    | 0     | 0 | 0                              | 0    | 0     | 0 | 0                         | 3    | 0     | 0 | 0                         | 0    | 0     | 0 | 3     | 44               |
| 12:10 PM                              | 0                              | 0    | 0     | 0 | 0                              | 0    | 0     | 0 | 1                         | 1    | 1     | 0 | 0                         | 0    | 0     | 0 | 3     | 46               |
| 12:15 PM                              | 0                              | 0    | 0     | 0 | 1                              | 0    | 0     | 0 | 1                         | 0    | 0     | 0 | 0                         | 0    | 0     | 0 | 2     | 48               |
| 12:20 PM                              | 1                              | 0    | 0     | 0 | 0                              | 0    | 0     | 0 | 0                         | 1    | 0     | 0 | 0                         | 0    | 0     | 0 | 2     | 45               |
| 12:25 PM                              | 0                              | 0    | 0     | 0 | 0                              | 0    | 0     | 0 | 0                         | 1    | 0     | 0 | 0                         | 0    | 0     | 0 | 1     | 43               |
| 12:30 PM                              | 1                              | 0    | 0     | 0 | 0                              | 0    | 2     | 0 | 0                         | 0    | 0     | 0 | 0                         | 0    | 0     | 0 | 3     | 39               |
| 12:35 PM                              | 0                              | 0    | 0     | 0 | 0                              | 0    | 0     | 0 | 0                         | 1    | 0     | 0 | 0                         | 2    | 0     | 0 | 3     | 36               |
| 12:40 PM                              | 1                              | 0    | 0     | 0 | 0                              | 0    | 0     | 0 | 1                         | 0    | 0     | 0 | 0                         | 0    | 0     | 0 | 2     | 32               |
| 12:45 PM                              | 0                              | 0    | 0     | 0 | 0                              | 0    | 0     | 0 | 1                         | 0    | 0     | 0 | 0                         | 0    | 0     | 0 | 1     | 33               |
| 12:50 PM                              | 0                              | 0    | 0     | 0 | 0                              | 0    | 0     | 0 | 0                         | 0    | 0     | 0 | 0                         | 1    | 0     | 0 | 1     | 32               |
| 12:55 PM                              | 0                              | 0    | 0     | 0 | 0                              | 0    | 0     | 0 | 0                         | 1    | 0     | 0 | 0                         | 0    | 0     | 0 | 1     | 28               |
| 1:00 PM                               | 0                              | 0    | 0     | 0 | 1                              | 0    | 0     | 0 | 0                         | 0    | 0     | 0 | 0                         | 0    | 0     | 0 | 1     | 23               |
| 1:05 PM                               | 0                              | 0    | 0     | 0 | 0                              | 0    | 0     | 0 | 2                         | 0    | 0     | 0 | 0                         | 0    | 0     | 0 | 2     | 22               |
| 1:10 PM                               | 0                              | 0    | 0     | 0 | 0                              | 0    | 0     | 0 | 0                         | 0    | 0     | 0 | 1                         | 0    | 0     | 0 | 1     | 20               |
| 1:15 PM                               | 0                              | 0    | 0     | 0 | 0                              | 0    | 0     | 0 | 0                         | 1    | 1     | 0 | 0                         | 0    | 1     | 0 | 3     | 21               |
| 1:20 PM                               | 0                              | 1    | 0     | 0 | 0                              | 0    | 0     | 0 | 0                         | 1    | 0     | 0 | 0                         | 0    | 0     | 0 | 2     | 21               |
| 1:25 PM                               | 0                              | 0    | 0     | 0 | 0                              | 0    | 2     | 0 | 0                         | 2    | 0     | 0 | 0                         | 0    | 0     | 0 | 4     | 24               |
| 1:30 PM                               | 0                              | 0    | 0     | 0 | 0                              | 0    | 0     | 0 | 0                         | 0    | 0     | 0 | 0                         | 1    | 0     | 0 | 1     | 22               |
| 1:35 PM                               | 1                              | 0    | 0     | 0 | 0                              | 0    | 0     | 0 | 0                         | 2    | 0     | 0 | 0                         | 1    | 0     | 0 | 4     | 23               |
| 1:40 PM                               | 0                              | 0    | 0     | 0 | 0                              | 0    | 0     | 0 | 0                         | 0    | 0     | 0 | 0                         | 4    | 0     | 0 | 4     | 25               |
| 1:45 PM                               | 1                              | 0    | 0     | 0 | 0                              | 0    | 0     | 0 | 0                         | 1    | 0     | 0 | 0                         | 2    | 0     | 0 | 4     | 28               |
| 1:50 PM                               | 0                              | 0    | 0     | 0 | 0                              | 0    | 0     | 0 | 0                         | 5    | 0     | 0 | 0                         | 3    | 0     | 0 | 8     | 35               |
| 1:55 PM                               | 0                              | 0    | 0     | 0 | 0                              | 0    | 0     | 0 | 0                         | 11   | 2     | 0 | 0                         | 1    | 0     | 0 | 14    | 48               |
| 2:00 PM                               | 1                              | 0    | 0     | 0 | 0                              | 0    | 0     | 0 | 0                         | 2    | 0     | 0 | 0                         | 2    | 0     | 0 | 5     | 52               |
| 2:05 PM                               | 1                              | 0    | 0     | 0 | 0                              | 0    | 0     | 0 | 0                         | 1    | 0     | 0 | 0                         | 2    | 0     | 0 | 4     | 54               |
| 2:10 PM                               | 0                              | 0    | 0     | 0 | 0                              | 0    | 0     | 0 | 1                         | 1    | 0     | 0 | 0                         | 3    | 0     | 0 | 5     | 58               |
| 2:15 PM                               | 1                              | 0    | 0     | 0 | 0                              | 0    | 1     | 0 | 0                         | 2    | 1     | 0 | 0                         | 2    | 0     | 0 | 7     | 62               |
| 2:20 PM                               | 0                              | 0    | 0     | 0 | 0                              | 0    | 0     | 0 | 0                         | 2    | 0     | 0 | 0                         | 6    | 0     | 0 | 8     | 68               |
| 2:25 PM                               | 2                              | 0    | 0     | 0 | 0                              | 1    | 2     | 0 | 1                         | 2    | 0     | 0 | 0                         | 2    | 0     | 0 | 10    | 74               |
| 2:30 PM                               | 0                              | 0    | 0     | 0 | 0                              | 0    | 0     | 0 | 1                         | 0    | 0     | 0 | 0                         | 8    | 0     | 0 | 9     | 82               |
| 2:35 PM                               | 0                              | 0    | 0     | 0 | 0                              | 0    | 1     | 0 | 0                         | 1    | 1     | 0 | 0                         | 8    | 0     | 0 | 11    | 89               |
| 2:40 PM                               | 0                              | 0    | 0     | 0 | 0                              | 0    | 0     | 0 | 0                         | 11   | 0     | 0 | 0                         | 3    | 0     | 0 | 14    | 99               |
| 2:45 PM                               | 0                              | 0    | 0     | 0 | 0                              | 0    | 0     | 0 | 0                         | 30   | 1     | 0 | 0                         | 4    | 1     | 0 | 36    | 131              |
| 2:50 PM                               | 0                              | 0    | 0     | 0 | 1                              | 0    | 0     | 0 | 0                         | 5    | 0     | 0 | 0                         | 1    | 0     | 0 | 7     | 130              |
| 2:55 PM                               | 0                              | 0    | 0     | 0 | 0                              | 0    | 0     | 0 | 0                         | 3    | 0     | 0 | 0                         | 0    | 0     | 0 | 3     | 119              |
| 3:00 PM                               | 0                              | 0    | 0     | 0 | 0                              | 0    | 0     | 0 | 0                         | 2    | 0     | 0 | 0                         | 1    | 0     | 0 | 3     | 117              |
| 3:05 PM                               | 0                              | 0    | 0     | 0 | 0                              | 0    | 0     | 0 | 0                         | 0    | 0     | 0 | 0                         | 3    | 0     | 0 | 3     | 116              |
| 3:10 PM                               | 0                              | 0    | 0     | 0 | 0                              | 0    | 0     | 0 | 1                         | 3    | 0     | 0 | 0                         | 2    | 0     | 0 | 6     | 117              |
| 3:15 PM                               | 0                              | 0    | 0     | 0 | 0                              | 0    | 0     | 0 | 0                         | 3    | 1     | 0 | 0                         | 2    | 0     | 0 | 6     | 116              |
| 3:20 PM                               | 1                              | 0    | 0     | 0 | 0                              | 0    | 0     | 0 | 0                         | 1    | 0     | 0 | 0                         | 1    | 0     | 0 | 3     | 111              |
| 3:25 PM                               | 2                              | 0    | 0     | 0 | 0                              | 0    | 0     | 0 | 1                         | 0    | 1     | 0 | 0                         | 3    | 0     | 0 | 7     | 108              |
| 3:30 PM                               | 1                              | 0    | 0     | 0 | 0                              | 0    | 1     | 0 | 0                         | 1    | 0     | 0 | 0                         | 2    | 0     | 0 | 5     | 104              |
| 3:35 PM                               | 0                              | 0    | 0     | 0 | 0                              | 0    | 1     | 0 | 0                         | 0    | 2     | 0 | 0                         | 1    | 0     | 0 | 4     | 97               |
| 3:40 PM                               | 0                              | 0    | 0     | 0 | 0                              | 0    | 0     | 0 | 0                         | 0    | 0     | 0 | 1                         | 3    | 0     | 0 | 4     | 87               |
| 3:45 PM                               | 1                              | 0    | 0     | 0 | 0                              | 0    | 0     | 0 | 0                         | 3    | 2     | 0 | 0                         | 0    | 0     | 0 | 6     | 57               |
| 3:50 PM                               | 0                              | 0    | 1     | 0 | 0                              | 0    | 0     | 0 | 1                         | 0    | 1     | 0 | 0                         | 3    | 0     | 0 | 6     | 56               |
| 3:55 PM                               | 0                              | 0    | 0     | 0 | 0                              | 0    | 0     | 0 | 0                         | 3    | 0     | 0 | 0                         | 2    | 0     | 0 | 5     | 58               |
| 4:00 PM                               | 0                              | 0    | 0     | 0 | 0                              | 0    | 0     | 0 | 0                         | 1    | 0     | 0 | 0                         | 0    | 0     | 0 | 1     | 56               |
| 4:05 PM                               | 0                              | 0    | 0     | 0 | 0                              | 0    | 0     | 0 | 0                         | 1    | 0     | 0 | 0                         | 1    | 0     | 0 | 2     | 55               |
| 4:10 PM                               | 1                              | 0    | 0     | 0 | 0                              | 0    | 1     | 0 | 0                         | 1    | 0     | 0 | 0                         | 0    | 1     | 0 | 4     | 53               |
| 4:15 PM                               | 1                              | 0    | 0     | 0 | 0                              | 0    | 0     | 0 | 1                         | 2    | 0     | 0 | 0                         | 0    | 0     | 0 | 4     | 51               |
| 4:20 PM                               | 0                              | 0    | 0     | 0 | 0                              | 0    | 0     | 0 | 0                         | 2    | 1     | 0 | 0                         | 1    | 0     | 0 | 3     | 51               |
| 4:25 PM                               | 1                              | 0    | 0     | 0 | 0                              | 0    | 0     | 0 | 1                         | 1    | 1     | 0 | 0                         | 2    | 0     | 0 | 6     | 50               |
| 4:30 PM                               | 0                              | 0    | 0     | 0 | 0                              | 0    | 0     | 0 | 0                         | 1    | 2     | 0 | 0                         | 2    | 0     | 0 | 5     | 50               |

## Attachment B

| 5-Min Count Period Beginning At | Cherry Hill Dr (Northbound) |      |       |   | Cherry Hill Dr (Southbound) |      |       |   | Coronel Rd (Eastbound) |      |       |   | Coronel Rd (Westbound) |      |       |   | Total | Hourly Totals |    |
|---------------------------------|-----------------------------|------|-------|---|-----------------------------|------|-------|---|------------------------|------|-------|---|------------------------|------|-------|---|-------|---------------|----|
|                                 | Left                        | Thru | Right | U | Left                        | Thru | Right | U | Left                   | Thru | Right | U | Left                   | Thru | Right | U |       |               |    |
| 4:35 PM                         | 0                           | 0    | 0     | 0 | 0                           | 0    | 0     | 0 | 0                      | 2    | 1     | 0 | 0                      | 0    | 1     | 0 | 0     | 3             | 49 |
| 4:40 PM                         | 0                           | 0    | 0     | 0 | 0                           | 0    | 0     | 0 | 0                      | 2    | 1     | 0 | 0                      | 0    | 0     | 0 | 0     | 3             | 48 |
| 4:45 PM                         | 0                           | 0    | 0     | 0 | 0                           | 0    | 0     | 0 | 0                      | 0    | 1     | 0 | 0                      | 0    | 1     | 0 | 0     | 2             | 44 |
| 4:50 PM                         | 0                           | 0    | 0     | 0 | 0                           | 0    | 0     | 0 | 0                      | 0    | 4     | 0 | 0                      | 0    | 1     | 0 | 0     | 5             | 43 |
| 4:55 PM                         | 0                           | 0    | 0     | 0 | 0                           | 0    | 1     | 0 | 1                      | 2    | 2     | 0 | 0                      | 0    | 1     | 0 | 0     | 7             | 45 |
| 5:00 PM                         | 1                           | 0    | 0     | 0 | 0                           | 0    | 0     | 0 | 0                      | 2    | 0     | 0 | 0                      | 0    | 0     | 0 | 0     | 3             | 47 |
| 5:05 PM                         | 0                           | 0    | 1     | 0 | 0                           | 0    | 0     | 0 | 0                      | 1    | 1     | 0 | 0                      | 0    | 1     | 0 | 0     | 4             | 49 |
| 5:10 PM                         | 2                           | 0    | 0     | 0 | 0                           | 0    | 1     | 0 | 0                      | 0    | 0     | 0 | 0                      | 0    | 3     | 0 | 0     | 6             | 51 |
| 5:15 PM                         | 1                           | 0    | 0     | 0 | 0                           | 0    | 0     | 0 | 0                      | 4    | 0     | 0 | 0                      | 0    | 1     | 0 | 0     | 6             | 53 |
| 5:20 PM                         | 0                           | 0    | 0     | 0 | 0                           | 0    | 0     | 0 | 0                      | 0    | 0     | 0 | 0                      | 0    | 0     | 0 | 0     | 0             | 50 |
| 5:25 PM                         | 0                           | 0    | 0     | 0 | 0                           | 0    | 0     | 0 | 0                      | 3    | 0     | 0 | 0                      | 0    | 0     | 0 | 0     | 3             | 47 |
| 5:30 PM                         | 0                           | 0    | 0     | 0 | 0                           | 0    | 0     | 0 | 0                      | 1    | 1     | 0 | 0                      | 0    | 1     | 1 | 0     | 4             | 46 |
| 5:35 PM                         | 2                           | 0    | 0     | 0 | 0                           | 0    | 0     | 0 | 0                      | 0    | 1     | 0 | 0                      | 0    | 0     | 0 | 0     | 3             | 46 |
| 5:40 PM                         | 0                           | 0    | 0     | 0 | 1                           | 1    | 0     | 0 | 1                      | 2    | 0     | 0 | 0                      | 0    | 1     | 1 | 0     | 7             | 50 |
| 5:45 PM                         | 0                           | 0    | 0     | 0 | 0                           | 0    | 2     | 0 | 2                      | 1    | 0     | 0 | 0                      | 0    | 0     | 0 | 0     | 5             | 53 |
| 5:50 PM                         | 2                           | 0    | 0     | 0 | 1                           | 0    | 1     | 0 | 0                      | 3    | 2     | 0 | 0                      | 0    | 2     | 0 | 0     | 11            | 59 |
| 5:55 PM                         | 0                           | 0    | 0     | 0 | 0                           | 0    | 0     | 0 | 0                      | 1    | 0     | 0 | 0                      | 0    | 0     | 0 | 0     | 1             | 53 |
| 6:00 PM                         | 1                           | 0    | 0     | 0 | 0                           | 0    | 0     | 0 | 0                      | 0    | 0     | 0 | 0                      | 0    | 0     | 0 | 0     | 1             | 51 |
| 6:05 PM                         | 0                           | 0    | 0     | 0 | 0                           | 0    | 0     | 0 | 0                      | 1    | 0     | 0 | 0                      | 0    | 1     | 0 | 0     | 2             | 49 |
| 6:10 PM                         | 0                           | 0    | 0     | 0 | 0                           | 0    | 0     | 0 | 0                      | 1    | 2     | 0 | 0                      | 0    | 0     | 0 | 0     | 3             | 46 |
| 6:15 PM                         | 0                           | 0    | 0     | 0 | 0                           | 0    | 0     | 0 | 0                      | 0    | 1     | 0 | 0                      | 0    | 0     | 0 | 0     | 1             | 41 |
| 6:20 PM                         | 0                           | 0    | 0     | 0 | 0                           | 0    | 1     | 0 | 0                      | 0    | 2     | 0 | 0                      | 0    | 0     | 0 | 0     | 3             | 44 |
| 6:25 PM                         | 0                           | 0    | 1     | 0 | 0                           | 0    | 0     | 0 | 0                      | 1    | 0     | 0 | 0                      | 0    | 1     | 0 | 0     | 3             | 44 |
| 6:30 PM                         | 0                           | 0    | 0     | 0 | 0                           | 0    | 0     | 0 | 0                      | 0    | 0     | 0 | 0                      | 0    | 0     | 0 | 0     | 0             | 40 |
| 6:35 PM                         | 0                           | 0    | 0     | 0 | 0                           | 0    | 0     | 0 | 1                      | 0    | 2     | 0 | 0                      | 0    | 0     | 1 | 0     | 4             | 41 |
| 6:40 PM                         | 1                           | 0    | 0     | 0 | 0                           | 0    | 1     | 0 | 0                      | 1    | 0     | 0 | 0                      | 0    | 0     | 0 | 0     | 3             | 37 |
| 6:45 PM                         | 0                           | 0    | 0     | 0 | 0                           | 0    | 0     | 0 | 0                      | 1    | 0     | 0 | 0                      | 2    | 0     | 0 | 0     | 3             | 35 |
| 6:50 PM                         | 1                           | 0    | 0     | 0 | 0                           | 0    | 0     | 0 | 0                      | 1    | 0     | 0 | 0                      | 0    | 1     | 0 | 0     | 3             | 27 |
| 6:55 PM                         | 0                           | 0    | 0     | 0 | 0                           | 0    | 0     | 0 | 1                      | 2    | 0     | 0 | 0                      | 0    | 0     | 0 | 0     | 3             | 29 |
| 7:00 PM                         | 0                           | 0    | 0     | 0 | 0                           | 0    | 0     | 0 | 0                      | 2    | 1     | 0 | 0                      | 0    | 2     | 0 | 0     | 5             | 33 |
| 7:05 PM                         | 1                           | 0    | 0     | 0 | 0                           | 0    | 1     | 0 | 1                      | 1    | 0     | 0 | 0                      | 0    | 0     | 0 | 0     | 4             | 35 |
| 7:10 PM                         | 0                           | 0    | 0     | 0 | 0                           | 0    | 1     | 0 | 1                      | 0    | 1     | 0 | 0                      | 0    | 0     | 0 | 0     | 3             | 35 |
| 7:15 PM                         | 1                           | 0    | 0     | 0 | 1                           | 0    | 0     | 0 | 1                      | 0    | 0     | 0 | 0                      | 0    | 1     | 0 | 0     | 4             | 38 |
| 7:20 PM                         | 0                           | 0    | 0     | 0 | 0                           | 0    | 0     | 0 | 0                      | 2    | 0     | 0 | 0                      | 0    | 0     | 0 | 0     | 2             | 37 |
| 7:25 PM                         | 0                           | 0    | 0     | 0 | 0                           | 0    | 0     | 0 | 0                      | 1    | 0     | 0 | 0                      | 0    | 0     | 0 | 0     | 1             | 35 |
| 7:30 PM                         | 1                           | 0    | 0     | 0 | 0                           | 0    | 0     | 0 | 0                      | 2    | 0     | 0 | 0                      | 0    | 1     | 0 | 0     | 4             | 39 |
| 7:35 PM                         | 1                           | 0    | 0     | 0 | 0                           | 0    | 0     | 0 | 1                      | 0    | 2     | 0 | 0                      | 0    | 0     | 0 | 0     | 4             | 39 |
| 7:40 PM                         | 0                           | 0    | 0     | 0 | 0                           | 0    | 0     | 0 | 1                      | 1    | 0     | 0 | 0                      | 0    | 0     | 0 | 0     | 2             | 38 |
| 7:45 PM                         | 0                           | 0    | 0     | 0 | 0                           | 0    | 0     | 0 | 0                      | 2    | 0     | 0 | 0                      | 0    | 0     | 0 | 0     | 2             | 37 |
| 7:50 PM                         | 0                           | 0    | 0     | 0 | 0                           | 0    | 0     | 0 | 2                      | 0    | 0     | 0 | 0                      | 0    | 0     | 0 | 0     | 2             | 36 |
| 7:55 PM                         | 0                           | 0    | 0     | 0 | 0                           | 0    | 0     | 0 | 0                      | 0    | 0     | 0 | 0                      | 0    | 1     | 0 | 0     | 1             | 34 |
| 8:00 PM                         | 0                           | 0    | 0     | 0 | 0                           | 0    | 0     | 0 | 0                      | 0    | 0     | 0 | 0                      | 0    | 0     | 0 | 0     | 0             | 29 |
| 8:05 PM                         | 1                           | 0    | 0     | 0 | 0                           | 0    | 0     | 0 | 0                      | 0    | 0     | 0 | 0                      | 0    | 0     | 0 | 0     | 1             | 26 |
| 8:10 PM                         | 0                           | 0    | 0     | 0 | 0                           | 0    | 0     | 0 | 0                      | 0    | 1     | 0 | 0                      | 0    | 0     | 0 | 0     | 1             | 24 |
| 8:15 PM                         | 0                           | 0    | 0     | 0 | 0                           | 0    | 0     | 0 | 0                      | 0    | 0     | 0 | 0                      | 0    | 0     | 0 | 0     | 0             | 20 |
| 8:20 PM                         | 1                           | 0    | 0     | 0 | 0                           | 0    | 0     | 0 | 0                      | 0    | 0     | 0 | 0                      | 0    | 0     | 0 | 0     | 1             | 19 |
| 8:25 PM                         | 0                           | 0    | 0     | 0 | 0                           | 0    | 0     | 0 | 1                      | 1    | 0     | 0 | 0                      | 0    | 1     | 0 | 0     | 3             | 21 |
| 8:30 PM                         | 0                           | 0    | 0     | 0 | 0                           | 0    | 0     | 0 | 1                      | 1    | 0     | 0 | 0                      | 0    | 0     | 0 | 0     | 2             | 19 |
| 8:35 PM                         | 1                           | 0    | 0     | 0 | 0                           | 0    | 0     | 0 | 0                      | 0    | 0     | 0 | 0                      | 0    | 0     | 0 | 0     | 1             | 16 |
| 8:40 PM                         | 1                           | 0    | 0     | 0 | 0                           | 0    | 0     | 0 | 0                      | 1    | 2     | 0 | 0                      | 0    | 1     | 0 | 0     | 5             | 19 |
| 8:45 PM                         | 0                           | 0    | 0     | 0 | 0                           | 0    | 0     | 0 | 0                      | 0    | 0     | 0 | 0                      | 0    | 0     | 0 | 0     | 0             | 17 |
| 8:50 PM                         | 0                           | 0    | 0     | 0 | 0                           | 0    | 0     | 0 | 0                      | 0    | 0     | 0 | 0                      | 0    | 0     | 0 | 0     | 0             | 15 |
| 8:55 PM                         | 0                           | 0    | 0     | 0 | 0                           | 0    | 0     | 0 | 1                      | 1    | 0     | 0 | 0                      | 0    | 0     | 0 | 0     | 2             | 16 |
| 9:00 PM                         | 0                           | 0    | 0     | 0 | 0                           | 0    | 0     | 0 | 0                      | 2    | 0     | 0 | 0                      | 0    | 0     | 0 | 0     | 2             | 18 |
| 9:05 PM                         | 0                           | 0    | 0     | 0 | 0                           | 0    | 0     | 0 | 0                      | 0    | 0     | 0 | 0                      | 0    | 0     | 0 | 0     | 0             | 17 |
| 9:10 PM                         | 0                           | 0    | 0     | 0 | 0                           | 0    | 0     | 0 | 0                      | 0    | 0     | 0 | 0                      | 0    | 0     | 1 | 0     | 1             | 17 |
| 9:15 PM                         | 0                           | 0    | 0     | 0 | 0                           | 0    | 0     | 0 | 0                      | 2    | 0     | 0 | 0                      | 0    | 0     | 0 | 0     | 2             | 19 |
| 9:20 PM                         | 0                           | 0    | 0     | 0 | 0                           | 0    | 0     | 0 | 0                      | 0    | 0     | 0 | 0                      | 0    | 1     | 0 | 0     | 1             | 19 |
| 9:25 PM                         | 0                           | 0    | 0     | 0 | 0                           | 0    | 0     | 0 | 0                      | 0    | 0     | 0 | 0                      | 0    | 0     | 0 | 0     | 0             | 16 |
| 9:30 PM                         | 0                           | 0    | 0     | 0 | 0                           | 0    | 0     | 0 | 0                      | 0    | 1     | 0 | 0                      | 0    | 1     | 0 | 0     | 2             | 16 |
| 9:35 PM                         | 0                           | 0    | 0     | 0 | 0                           | 0    | 0     | 0 | 0                      | 0    | 0     | 0 | 0                      | 0    | 0     | 0 | 0     | 0             | 15 |
| 9:40 PM                         | 0                           | 0    | 0     | 0 | 0                           | 0    | 0     | 0 | 0                      | 1    | 0     | 0 | 0                      | 0    | 0     | 0 | 0     | 1             | 11 |
| 9:45 PM                         | 0                           | 0    | 0     | 0 | 0                           | 0    | 0     | 0 | 0                      | 1    | 0     | 0 | 0                      | 0    | 1     | 0 | 0     | 2             | 13 |
| 9:50 PM                         | 0                           | 0    | 0     | 0 | 0                           | 0    | 0     | 0 | 0                      | 0    | 0     | 0 | 0                      | 0    | 0     | 0 | 0     | 0             | 13 |
| 9:55 PM                         | 0                           | 0    | 0     | 0 | 0                           | 0    | 0     | 0 | 0                      | 1    | 1     | 0 | 0                      | 0    | 0     | 0 | 0     | 2             | 13 |
| Peak 15-Min Flowrates           | Northbound                  |      |       |   | Southbound                  |      |       |   | Eastbound              |      |       |   | Westbound              |      |       |   | Total |               |    |
|                                 | Left                        | Thru | Right | U | Left                        | Thru | Right | U | Left                   | Thru | Right | U | Left                   | Thru | Right | U |       |               |    |
| All Vehicles                    | 12                          | 0    | 0     | 0 | 0                           | 0    | 4     | 0 | 0                      | 216  | 8     | 0 | 0                      | 340  | 0     | 0 | 580   |               |    |
| Heavy Trucks                    | 0                           | 0    | 0     | 0 | 0                           | 0    | 0     | 0 | 0                      | 0    | 0     | 0 | 0                      | 0    | 0     | 0 | 0     |               |    |
| Buses                           |                             |      |       |   |                             |      |       |   |                        |      |       |   |                        |      |       |   |       |               |    |
| Pedestrians                     |                             | 16   |       |   |                             | 0    |       |   |                        | 0    |       |   |                        | 0    |       |   | 16    |               |    |
| Bicycles                        | 0                           | 0    | 0     |   | 0                           | 0    | 0     |   | 0                      | 0    | 0     |   | 0                      | 0    | 0     |   | 0     |               |    |
| Scoters                         |                             |      |       |   |                             |      |       |   |                        |      |       |   |                        |      |       |   |       |               |    |

Comments:

LOCATION: Bimini Dr -- Cambera Ln  
 CITY/STATE: North Tustin, CA

QC JOB #: 16966436  
 DATE: Thu, Apr 10 2025

Peak-Hour: 7:10 AM -- 8:10 AM  
 Peak 15-Min: 7:55 AM -- 8:10 AM

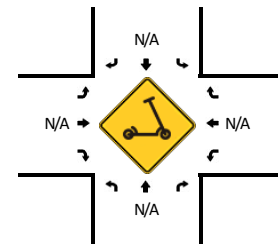
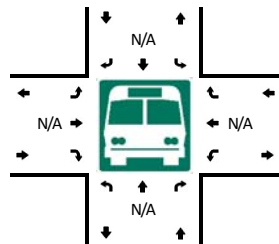
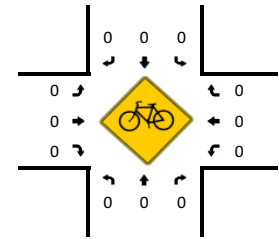
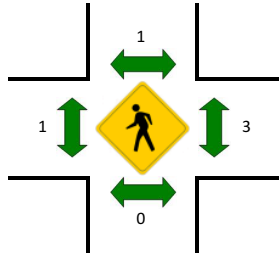
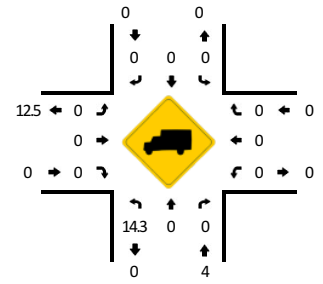
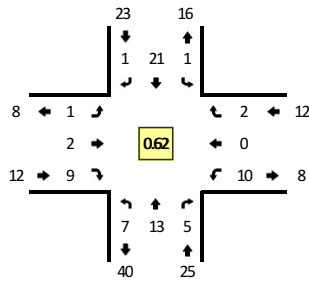

| 5-Min Count Period Beginning At | Bimini Dr (Northbound) |      |       |   | Bimini Dr (Southbound) |      |       |   | Cambera Ln (Eastbound) |      |       |   | Cambera Ln (Westbound) |      |       |   | Total | Hourly Totals |   |   |   |   |   |   |    |
|---------------------------------|------------------------|------|-------|---|------------------------|------|-------|---|------------------------|------|-------|---|------------------------|------|-------|---|-------|---------------|---|---|---|---|---|---|----|
|                                 | Left                   | Thru | Right | U | Left                   | Thru | Right | U | Left                   | Thru | Right | U | Left                   | Thru | Right | U |       |               |   |   |   |   |   |   |    |
| 6:00 AM                         | 0                      | 0    | 0     | 0 | 0                      | 0    | 0     | 0 | 0                      | 0    | 0     | 0 | 0                      | 0    | 0     | 0 | 0     | 0             | 0 | 0 | 0 | 0 | 0 | 0 | 0  |
| 6:05 AM                         | 0                      | 0    | 0     | 0 | 0                      | 0    | 0     | 0 | 0                      | 0    | 0     | 0 | 0                      | 0    | 0     | 0 | 0     | 0             | 0 | 0 | 0 | 0 | 0 | 0 | 0  |
| 6:10 AM                         | 0                      | 1    | 0     | 0 | 1                      | 0    | 0     | 0 | 0                      | 0    | 0     | 1 | 0                      | 0    | 0     | 0 | 0     | 0             | 0 | 0 | 0 | 0 | 0 | 0 | 3  |
| 6:15 AM                         | 0                      | 0    | 0     | 0 | 0                      | 0    | 0     | 0 | 0                      | 0    | 0     | 0 | 0                      | 0    | 0     | 0 | 0     | 0             | 0 | 0 | 0 | 1 | 0 | 0 | 1  |
| 6:20 AM                         | 0                      | 0    | 0     | 0 | 0                      | 0    | 0     | 0 | 0                      | 0    | 0     | 0 | 0                      | 0    | 0     | 0 | 0     | 0             | 0 | 0 | 0 | 0 | 0 | 0 | 0  |
| 6:25 AM                         | 0                      | 0    | 0     | 0 | 0                      | 0    | 0     | 0 | 0                      | 0    | 0     | 0 | 0                      | 0    | 0     | 0 | 0     | 0             | 0 | 0 | 0 | 0 | 0 | 0 | 0  |
| 6:30 AM                         | 0                      | 0    | 0     | 0 | 0                      | 0    | 0     | 0 | 0                      | 0    | 0     | 0 | 0                      | 0    | 0     | 0 | 0     | 0             | 0 | 0 | 0 | 0 | 0 | 0 | 0  |
| 6:35 AM                         | 0                      | 0    | 0     | 0 | 0                      | 2    | 0     | 0 | 0                      | 0    | 0     | 0 | 0                      | 0    | 0     | 0 | 0     | 0             | 0 | 0 | 0 | 0 | 0 | 0 | 2  |
| 6:40 AM                         | 0                      | 0    | 0     | 0 | 0                      | 0    | 0     | 0 | 0                      | 0    | 0     | 0 | 0                      | 0    | 0     | 0 | 0     | 0             | 0 | 0 | 0 | 0 | 0 | 0 | 1  |
| 6:45 AM                         | 1                      | 0    | 0     | 0 | 0                      | 0    | 0     | 0 | 0                      | 0    | 0     | 0 | 0                      | 0    | 0     | 0 | 0     | 0             | 0 | 0 | 0 | 0 | 0 | 0 | 1  |
| 6:50 AM                         | 0                      | 0    | 0     | 0 | 0                      | 2    | 0     | 0 | 0                      | 0    | 0     | 0 | 1                      | 0    | 0     | 0 | 0     | 0             | 0 | 0 | 0 | 0 | 0 | 0 | 3  |
| 6:55 AM                         | 0                      | 0    | 0     | 0 | 0                      | 0    | 0     | 0 | 0                      | 0    | 0     | 2 | 0                      | 0    | 0     | 0 | 0     | 0             | 0 | 0 | 0 | 0 | 0 | 0 | 2  |
| 7:00 AM                         | 0                      | 0    | 0     | 0 | 0                      | 0    | 0     | 0 | 0                      | 0    | 0     | 1 | 0                      | 0    | 0     | 0 | 0     | 0             | 0 | 0 | 0 | 0 | 0 | 0 | 1  |
| 7:05 AM                         | 0                      | 0    | 0     | 0 | 0                      | 0    | 0     | 0 | 0                      | 0    | 0     | 1 | 0                      | 0    | 0     | 0 | 0     | 0             | 0 | 0 | 0 | 0 | 0 | 0 | 1  |
| 7:10 AM                         | 1                      | 0    | 0     | 0 | 0                      | 3    | 1     | 0 | 0                      | 0    | 0     | 1 | 0                      | 1    | 0     | 0 | 0     | 0             | 0 | 0 | 0 | 0 | 0 | 0 | 7  |
| 7:15 AM                         | 0                      | 0    | 1     | 0 | 0                      | 1    | 0     | 0 | 0                      | 0    | 1     | 1 | 0                      | 1    | 0     | 1 | 0     | 0             | 0 | 0 | 0 | 0 | 0 | 0 | 6  |
| 7:20 AM                         | 0                      | 0    | 0     | 0 | 0                      | 0    | 0     | 0 | 0                      | 0    | 0     | 2 | 0                      | 1    | 0     | 0 | 0     | 0             | 0 | 0 | 0 | 0 | 0 | 0 | 3  |
| 7:25 AM                         | 3                      | 1    | 1     | 0 | 0                      | 0    | 0     | 0 | 0                      | 0    | 0     | 0 | 0                      | 0    | 0     | 0 | 0     | 0             | 0 | 0 | 0 | 0 | 0 | 0 | 5  |
| 7:30 AM                         | 0                      | 1    | 0     | 0 | 0                      | 0    | 0     | 0 | 0                      | 0    | 0     | 0 | 0                      | 1    | 0     | 1 | 0     | 0             | 0 | 0 | 0 | 0 | 0 | 0 | 3  |
| 7:35 AM                         | 1                      | 0    | 0     | 0 | 0                      | 1    | 0     | 0 | 0                      | 0    | 0     | 1 | 0                      | 0    | 0     | 0 | 0     | 0             | 0 | 0 | 0 | 0 | 0 | 0 | 3  |
| 7:40 AM                         | 0                      | 0    | 1     | 0 | 0                      | 1    | 0     | 0 | 0                      | 0    | 0     | 0 | 0                      | 0    | 0     | 0 | 0     | 0             | 0 | 0 | 0 | 0 | 0 | 0 | 2  |
| 7:45 AM                         | 1                      | 1    | 0     | 0 | 0                      | 3    | 0     | 0 | 0                      | 0    | 0     | 1 | 0                      | 1    | 0     | 0 | 0     | 0             | 0 | 0 | 0 | 0 | 0 | 0 | 7  |
| 7:50 AM                         | 0                      | 2    | 0     | 0 | 1                      | 3    | 0     | 0 | 0                      | 0    | 1     | 0 | 0                      | 0    | 0     | 0 | 0     | 0             | 0 | 0 | 0 | 0 | 0 | 0 | 7  |
| 7:55 AM                         | 0                      | 4    | 1     | 0 | 0                      | 1    | 0     | 0 | 0                      | 0    | 0     | 1 | 0                      | 3    | 0     | 0 | 0     | 0             | 0 | 0 | 0 | 0 | 0 | 0 | 10 |
| 8:00 AM                         | 0                      | 2    | 0     | 0 | 0                      | 2    | 0     | 0 | 0                      | 0    | 0     | 0 | 0                      | 0    | 0     | 0 | 0     | 0             | 0 | 0 | 0 | 0 | 0 | 0 | 4  |
| 8:05 AM                         | 1                      | 2    | 1     | 0 | 0                      | 6    | 0     | 0 | 0                      | 1    | 0     | 2 | 0                      | 2    | 0     | 0 | 0     | 0             | 0 | 0 | 0 | 0 | 0 | 0 | 15 |
| 8:10 AM                         | 0                      | 2    | 1     | 0 | 0                      | 1    | 0     | 0 | 0                      | 0    | 0     | 0 | 0                      | 0    | 0     | 0 | 0     | 0             | 0 | 0 | 0 | 0 | 0 | 0 | 4  |
| 8:15 AM                         | 0                      | 0    | 1     | 0 | 0                      | 3    | 0     | 0 | 0                      | 0    | 0     | 1 | 0                      | 0    | 0     | 0 | 0     | 0             | 0 | 0 | 0 | 0 | 0 | 0 | 5  |
| 8:20 AM                         | 1                      | 1    | 0     | 0 | 0                      | 3    | 1     | 0 | 0                      | 0    | 0     | 0 | 0                      | 0    | 0     | 1 | 0     | 0             | 0 | 0 | 0 | 0 | 0 | 0 | 7  |
| 8:25 AM                         | 1                      | 0    | 0     | 0 | 0                      | 0    | 0     | 0 | 0                      | 0    | 0     | 1 | 0                      | 0    | 0     | 0 | 0     | 0             | 0 | 0 | 0 | 0 | 0 | 0 | 2  |
| 8:30 AM                         | 0                      | 0    | 0     | 0 | 0                      | 0    | 0     | 0 | 0                      | 0    | 0     | 3 | 0                      | 0    | 0     | 0 | 0     | 0             | 0 | 0 | 0 | 0 | 0 | 0 | 3  |
| 8:35 AM                         | 0                      | 0    | 0     | 0 | 0                      | 0    | 0     | 0 | 0                      | 0    | 0     | 0 | 0                      | 2    | 0     | 0 | 0     | 0             | 0 | 0 | 0 | 0 | 0 | 0 | 2  |
| 8:40 AM                         | 0                      | 0    | 0     | 0 | 0                      | 0    | 0     | 0 | 0                      | 0    | 0     | 0 | 0                      | 0    | 0     | 0 | 0     | 0             | 0 | 0 | 0 | 0 | 0 | 0 | 0  |
| 8:45 AM                         | 0                      | 0    | 0     | 0 | 0                      | 0    | 1     | 0 | 0                      | 0    | 0     | 1 | 0                      | 2    | 0     | 0 | 0     | 0             | 0 | 0 | 0 | 0 | 0 | 0 | 4  |
| 8:50 AM                         | 0                      | 0    | 1     | 0 | 0                      | 0    | 0     | 0 | 0                      | 0    | 0     | 0 | 0                      | 0    | 0     | 0 | 0     | 0             | 0 | 0 | 0 | 0 | 0 | 0 | 1  |
| 8:55 AM                         | 0                      | 0    | 1     | 0 | 0                      | 1    | 0     | 0 | 0                      | 0    | 0     | 0 | 0                      | 0    | 0     | 0 | 0     | 0             | 0 | 0 | 0 | 0 | 0 | 0 | 2  |
| 9:00 AM                         | 0                      | 0    | 0     | 0 | 0                      | 0    | 0     | 0 | 0                      | 0    | 0     | 1 | 0                      | 1    | 0     | 0 | 0     | 0             | 0 | 0 | 0 | 0 | 0 | 0 | 2  |
| 9:05 AM                         | 0                      | 0    | 0     | 0 | 1                      | 0    | 0     | 0 | 0                      | 0    | 0     | 0 | 0                      | 0    | 0     | 0 | 0     | 0             | 0 | 0 | 0 | 0 | 0 | 0 | 1  |

**Attachment B**

| 5-Min Count<br>Period<br>Beginning At | Bimini Dr<br>(Northbound) |      |       |   | Bimini Dr<br>(Southbound) |      |       |   | Cambera Ln<br>(Eastbound) |      |       |   | Cambera Ln<br>(Westbound) |      |       |   | Total | Hourly<br>Totals |
|---------------------------------------|---------------------------|------|-------|---|---------------------------|------|-------|---|---------------------------|------|-------|---|---------------------------|------|-------|---|-------|------------------|
|                                       | Left                      | Thru | Right | U | Left                      | Thru | Right | U | Left                      | Thru | Right | U | Left                      | Thru | Right | U |       |                  |
| 9:10 AM                               | 0                         | 1    | 0     | 0 | 0                         | 1    | 0     | 0 | 0                         | 0    | 0     | 0 | 0                         | 0    | 0     | 0 | 2     | 31               |
| 9:15 AM                               | 0                         | 0    | 1     | 0 | 0                         | 0    | 0     | 0 | 0                         | 0    | 0     | 0 | 0                         | 0    | 0     | 0 | 1     | 27               |
| 9:20 AM                               | 0                         | 1    | 0     | 0 | 0                         | 0    | 2     | 0 | 0                         | 0    | 0     | 0 | 0                         | 0    | 0     | 0 | 3     | 23               |
| 9:25 AM                               | 0                         | 0    | 0     | 0 | 0                         | 0    | 0     | 0 | 1                         | 0    | 1     | 0 | 0                         | 0    | 0     | 0 | 2     | 23               |
| 9:30 AM                               | 1                         | 0    | 1     | 0 | 0                         | 0    | 0     | 0 | 1                         | 0    | 0     | 0 | 1                         | 0    | 0     | 0 | 4     | 24               |
| 9:35 AM                               | 0                         | 0    | 0     | 0 | 0                         | 1    | 0     | 0 | 0                         | 0    | 0     | 0 | 0                         | 0    | 0     | 0 | 1     | 23               |
| 9:40 AM                               | 1                         | 0    | 0     | 0 | 0                         | 0    | 0     | 0 | 0                         | 0    | 0     | 0 | 0                         | 0    | 0     | 0 | 1     | 24               |
| 9:45 AM                               | 0                         | 0    | 0     | 0 | 0                         | 1    | 0     | 0 | 0                         | 0    | 0     | 0 | 1                         | 0    | 0     | 0 | 2     | 22               |
| 9:50 AM                               | 0                         | 0    | 0     | 0 | 0                         | 0    | 0     | 0 | 1                         | 0    | 1     | 0 | 0                         | 0    | 0     | 0 | 2     | 23               |
| 9:55 AM                               | 0                         | 0    | 0     | 0 | 0                         | 1    | 0     | 0 | 0                         | 0    | 1     | 0 | 0                         | 0    | 0     | 0 | 2     | 23               |
| 10:00 AM                              | 0                         | 0    | 1     | 0 | 0                         | 0    | 0     | 0 | 0                         | 0    | 0     | 0 | 0                         | 0    | 0     | 0 | 1     | 22               |
| 10:05 AM                              | 0                         | 0    | 0     | 0 | 0                         | 1    | 0     | 0 | 0                         | 0    | 0     | 0 | 1                         | 0    | 0     | 0 | 2     | 23               |
| 10:10 AM                              | 0                         | 0    | 0     | 0 | 0                         | 1    | 0     | 0 | 0                         | 0    | 1     | 0 | 0                         | 0    | 0     | 0 | 2     | 23               |
| 10:15 AM                              | 1                         | 0    | 0     | 0 | 0                         | 1    | 0     | 0 | 0                         | 0    | 1     | 0 | 0                         | 0    | 0     | 0 | 3     | 25               |
| 10:20 AM                              | 0                         | 0    | 0     | 0 | 0                         | 0    | 0     | 0 | 0                         | 0    | 0     | 0 | 0                         | 0    | 0     | 0 | 0     | 22               |
| 10:25 AM                              | 0                         | 0    | 0     | 0 | 0                         | 1    | 0     | 0 | 0                         | 0    | 0     | 0 | 0                         | 0    | 0     | 0 | 1     | 21               |
| 10:30 AM                              | 0                         | 0    | 1     | 0 | 0                         | 0    | 0     | 0 | 0                         | 0    | 0     | 0 | 1                         | 0    | 0     | 0 | 2     | 19               |
| 10:35 AM                              | 0                         | 1    | 0     | 0 | 0                         | 0    | 0     | 0 | 0                         | 0    | 1     | 0 | 0                         | 0    | 0     | 0 | 2     | 20               |
| 10:40 AM                              | 0                         | 1    | 0     | 0 | 0                         | 1    | 0     | 0 | 0                         | 0    | 0     | 0 | 0                         | 0    | 0     | 0 | 2     | 21               |
| 10:45 AM                              | 0                         | 2    | 0     | 0 | 0                         | 0    | 0     | 0 | 0                         | 0    | 0     | 0 | 0                         | 0    | 0     | 0 | 2     | 21               |
| 10:50 AM                              | 0                         | 0    | 0     | 0 | 0                         | 1    | 0     | 0 | 0                         | 0    | 0     | 0 | 1                         | 0    | 0     | 0 | 2     | 21               |
| 10:55 AM                              | 0                         | 0    | 0     | 0 | 0                         | 2    | 0     | 0 | 0                         | 0    | 0     | 1 | 0                         | 0    | 0     | 0 | 3     | 22               |
| 11:00 AM                              | 0                         | 0    | 0     | 0 | 0                         | 0    | 0     | 0 | 0                         | 0    | 0     | 0 | 0                         | 0    | 0     | 0 | 0     | 21               |
| 11:05 AM                              | 0                         | 0    | 0     | 0 | 0                         | 0    | 0     | 0 | 0                         | 0    | 0     | 0 | 0                         | 0    | 0     | 0 | 0     | 19               |
| 11:10 AM                              | 1                         | 0    | 1     | 0 | 1                         | 1    | 0     | 0 | 0                         | 0    | 0     | 0 | 0                         | 0    | 0     | 0 | 4     | 21               |
| 11:15 AM                              | 1                         | 0    | 0     | 0 | 0                         | 2    | 0     | 0 | 0                         | 0    | 0     | 0 | 2                         | 0    | 0     | 0 | 5     | 23               |
| 11:20 AM                              | 0                         | 0    | 1     | 0 | 0                         | 0    | 0     | 0 | 0                         | 0    | 0     | 0 | 0                         | 0    | 0     | 0 | 1     | 24               |
| 11:25 AM                              | 0                         | 0    | 0     | 0 | 0                         | 0    | 0     | 0 | 0                         | 0    | 1     | 0 | 1                         | 0    | 0     | 0 | 2     | 25               |
| 11:30 AM                              | 1                         | 2    | 1     | 0 | 0                         | 1    | 0     | 0 | 0                         | 0    | 0     | 0 | 0                         | 0    | 0     | 0 | 5     | 28               |
| 11:35 AM                              | 0                         | 0    | 0     | 0 | 0                         | 0    | 0     | 0 | 0                         | 0    | 0     | 0 | 0                         | 0    | 0     | 0 | 0     | 26               |
| 11:40 AM                              | 0                         | 0    | 0     | 0 | 0                         | 1    | 0     | 0 | 0                         | 0    | 0     | 0 | 0                         | 0    | 0     | 0 | 1     | 25               |
| 11:45 AM                              | 0                         | 0    | 0     | 0 | 0                         | 1    | 0     | 0 | 0                         | 0    | 0     | 0 | 2                         | 0    | 0     | 0 | 3     | 26               |
| 11:50 AM                              | 0                         | 0    | 0     | 0 | 0                         | 0    | 0     | 0 | 0                         | 0    | 2     | 0 | 0                         | 0    | 0     | 0 | 2     | 26               |
| 11:55 AM                              | 0                         | 0    | 0     | 0 | 0                         | 0    | 0     | 0 | 0                         | 0    | 0     | 0 | 0                         | 0    | 0     | 0 | 0     | 23               |
| 12:00 PM                              | 1                         | 0    | 0     | 0 | 0                         | 1    | 0     | 0 | 0                         | 0    | 0     | 0 | 0                         | 0    | 0     | 0 | 2     | 25               |
| 12:05 PM                              | 1                         | 0    | 2     | 0 | 0                         | 0    | 0     | 0 | 0                         | 0    | 0     | 0 | 0                         | 0    | 0     | 0 | 3     | 28               |
| 12:10 PM                              | 0                         | 0    | 1     | 0 | 0                         | 0    | 0     | 0 | 0                         | 0    | 0     | 0 | 0                         | 0    | 0     | 0 | 1     | 25               |
| 12:15 PM                              | 0                         | 1    | 0     | 0 | 0                         | 0    | 0     | 0 | 0                         | 0    | 0     | 0 | 1                         | 0    | 0     | 0 | 2     | 22               |
| 12:20 PM                              | 1                         | 0    | 2     | 0 | 0                         | 1    | 0     | 0 | 0                         | 0    | 0     | 0 | 0                         | 0    | 0     | 0 | 4     | 25               |
| 12:25 PM                              | 1                         | 0    | 0     | 0 | 0                         | 0    | 0     | 0 | 0                         | 0    | 0     | 0 | 0                         | 0    | 0     | 0 | 1     | 24               |
| 12:30 PM                              | 1                         | 0    | 1     | 0 | 0                         | 2    | 0     | 0 | 1                         | 0    | 0     | 0 | 0                         | 0    | 0     | 0 | 5     | 24               |
| 12:35 PM                              | 2                         | 0    | 0     | 0 | 1                         | 0    | 0     | 0 | 1                         | 0    | 1     | 0 | 0                         | 0    | 0     | 0 | 5     | 29               |
| 12:40 PM                              | 0                         | 0    | 0     | 0 | 0                         | 1    | 0     | 0 | 0                         | 0    | 1     | 0 | 1                         | 0    | 0     | 0 | 3     | 31               |
| 12:45 PM                              | 1                         | 0    | 0     | 0 | 0                         | 0    | 0     | 0 | 0                         | 0    | 0     | 0 | 0                         | 0    | 0     | 0 | 1     | 29               |
| 12:50 PM                              | 0                         | 0    | 2     | 0 | 0                         | 1    | 0     | 0 | 0                         | 0    | 1     | 0 | 0                         | 0    | 0     | 0 | 4     | 31               |
| 12:55 PM                              | 1                         | 0    | 0     | 0 | 0                         | 0    | 1     | 0 | 0                         | 0    | 0     | 0 | 0                         | 0    | 0     | 0 | 2     | 33               |
| 1:00 PM                               | 0                         | 0    | 1     | 0 | 0                         | 0    | 0     | 0 | 0                         | 0    | 1     | 0 | 0                         | 0    | 0     | 0 | 2     | 33               |
| 1:05 PM                               | 0                         | 0    | 0     | 0 | 0                         | 0    | 0     | 0 | 0                         | 0    | 2     | 0 | 1                         | 0    | 0     | 0 | 3     | 33               |
| 1:10 PM                               | 0                         | 0    | 1     | 0 | 0                         | 1    | 0     | 0 | 0                         | 0    | 0     | 0 | 0                         | 0    | 0     | 0 | 2     | 34               |
| 1:15 PM                               | 0                         | 0    | 1     | 0 | 0                         | 0    | 0     | 0 | 0                         | 0    | 0     | 0 | 2                         | 0    | 0     | 0 | 3     | 35               |
| 1:20 PM                               | 2                         | 1    | 0     | 0 | 0                         | 1    | 0     | 0 | 0                         | 0    | 0     | 0 | 1                         | 0    | 0     | 0 | 5     | 36               |
| 1:25 PM                               | 0                         | 0    | 2     | 0 | 0                         | 0    | 0     | 0 | 0                         | 0    | 0     | 0 | 0                         | 0    | 0     | 0 | 2     | 37               |
| 1:30 PM                               | 1                         | 1    | 0     | 0 | 0                         | 0    | 0     | 0 | 0                         | 0    | 0     | 0 | 0                         | 0    | 0     | 0 | 2     | 34               |
| 1:35 PM                               | 0                         | 0    | 0     | 0 | 0                         | 0    | 0     | 0 | 1                         | 0    | 0     | 0 | 0                         | 0    | 0     | 0 | 1     | 30               |
| 1:40 PM                               | 1                         | 1    | 0     | 0 | 0                         | 0    | 0     | 0 | 0                         | 0    | 0     | 0 | 0                         | 0    | 0     | 0 | 2     | 29               |
| 1:45 PM                               | 0                         | 0    | 0     | 0 | 0                         | 0    | 1     | 0 | 0                         | 0    | 0     | 0 | 0                         | 0    | 0     | 0 | 1     | 29               |
| 1:50 PM                               | 1                         | 1    | 0     | 0 | 1                         | 0    | 0     | 0 | 0                         | 1    | 2     | 0 | 0                         | 0    | 0     | 0 | 6     | 31               |
| 1:55 PM                               | 1                         | 0    | 0     | 0 | 0                         | 0    | 0     | 0 | 0                         | 0    | 0     | 0 | 0                         | 0    | 1     | 0 | 2     | 31               |
| 2:00 PM                               | 0                         | 0    | 0     | 0 | 0                         | 1    | 0     | 0 | 0                         | 0    | 0     | 0 | 0                         | 0    | 0     | 0 | 1     | 30               |
| 2:05 PM                               | 0                         | 1    | 1     | 0 | 0                         | 0    | 0     | 0 | 0                         | 0    | 0     | 0 | 1                         | 0    | 0     | 0 | 3     | 30               |
| 2:10 PM                               | 0                         | 0    | 0     | 0 | 0                         | 0    | 0     | 0 | 0                         | 0    | 0     | 0 | 0                         | 0    | 0     | 0 | 0     | 28               |
| 2:15 PM                               | 0                         | 0    | 0     | 0 | 0                         | 0    | 0     | 0 | 0                         | 0    | 0     | 0 | 0                         | 0    | 0     | 0 | 0     | 25               |
| 2:20 PM                               | 1                         | 0    | 0     | 0 | 1                         | 1    | 1     | 0 | 1                         | 0    | 0     | 0 | 0                         | 0    | 0     | 0 | 5     | 25               |
| 2:25 PM                               | 0                         | 2    | 1     | 0 | 0                         | 0    | 0     | 0 | 0                         | 0    | 2     | 0 | 1                         | 0    | 0     | 0 | 6     | 29               |
| 2:30 PM                               | 1                         | 0    | 1     | 0 | 0                         | 0    | 0     | 0 | 1                         | 0    | 0     | 0 | 0                         | 0    | 0     | 0 | 3     | 30               |
| 2:35 PM                               | 0                         | 0    | 0     | 0 | 0                         | 1    | 0     | 0 | 0                         | 0    | 0     | 0 | 0                         | 0    | 0     | 0 | 1     | 30               |
| 2:40 PM                               | 1                         | 2    | 1     | 0 | 0                         | 4    | 0     | 0 | 1                         | 0    | 0     | 0 | 0                         | 1    | 0     | 0 | 10    | 38               |
| 2:45 PM                               | 0                         | 0    | 0     | 0 | 0                         | 2    | 0     | 0 | 0                         | 0    | 0     | 0 | 2                         | 0    | 0     | 0 | 4     | 41               |
| 2:50 PM                               | 0                         | 0    | 0     | 0 | 0                         | 0    | 0     | 0 | 0                         | 0    | 2     | 0 | 2                         | 0    | 0     | 0 | 4     | 39               |
| 2:55 PM                               | 1                         | 1    | 0     | 0 | 0                         | 0    | 0     | 0 | 0                         | 0    | 0     | 0 | 0                         | 0    | 0     | 0 | 2     | 39               |
| 3:00 PM                               | 0                         | 0    | 1     | 0 | 0                         | 0    | 0     | 0 | 0                         | 0    | 2     | 0 | 1                         | 0    | 0     | 0 | 4     | 42               |
| 3:05 PM                               | 1                         | 1    | 2     | 0 | 0                         | 1    | 1     | 0 | 0                         | 0    | 1     | 0 | 0                         | 0    | 0     | 0 | 7     | 46               |
| 3:10 PM                               | 1                         | 0    | 1     | 0 | 0                         | 2    | 0     | 0 | 0                         | 0    | 0     | 0 | 1                         | 0    | 0     | 0 | 5     | 51               |
| 3:15 PM                               | 1                         | 0    | 1     | 0 | 0                         | 0    | 0     | 0 | 0                         | 0    | 0     | 0 | 0                         | 0    | 0     | 0 | 2     | 53               |
| 3:20 PM                               | 1                         | 1    | 1     | 0 | 0                         | 0    | 0     | 0 | 0                         | 0    | 1     | 0 | 1                         | 0    | 0     | 0 | 5     | 53               |
| 3:25 PM                               | 2                         | 1    | 0     | 0 | 0                         | 1    | 0     | 0 | 0                         | 0    | 0     | 0 | 1                         | 0    | 0     | 0 | 5     | 52               |
| 3:30 PM                               | 0                         | 2    | 2     | 0 | 0                         | 0    | 0     | 0 | 0                         | 0    | 0     | 0 | 1                         | 0    | 0     | 0 | 5     | 54               |
| 3:35 PM                               | 1                         | 0    | 1     | 0 | 0                         | 0    | 0     | 0 | 0                         | 0    | 0     | 0 | 2                         | 0    | 0     | 0 | 4     | 57               |
| 3:40 PM                               | 0                         | 0    | 1     | 0 | 0                         | 0    | 0     | 0 | 0                         | 0    | 1     | 0 | 1                         | 0    | 0     | 0 | 3     | 50               |
| 3:45 PM                               | 0                         | 1    | 1     | 0 | 0                         | 2    | 0     | 0 | 0                         | 0    | 0     | 0 | 1                         | 0    | 0     | 0 | 5     | 51               |
| 3:50 PM                               | 0                         | 0    | 2     | 0 | 0                         | 2    | 0     | 0 | 1                         | 0    | 0     | 0 | 1                         | 0    | 0     | 0 | 6     | 53               |
| 3:55 PM                               | 0                         | 0    | 2     | 0 | 0                         | 0    | 0     | 0 | 0                         | 0    | 0     | 0 | 0                         | 0    | 1     | 0 | 3     | 54               |
| 4:00 PM                               | 0                         | 0    | 1     | 0 | 0                         | 1    | 0     | 0 | 0                         | 0    | 2     | 0 | 1                         | 0    | 1     | 0 | 6     | 56               |
| 4:05 PM                               | 1                         | 0    | 1     | 0 | 0                         | 0    | 0     | 0 | 0                         | 0    | 0     | 0 | 2                         | 0    | 0     | 0 | 4     | 53               |
| 4:10 PM                               | 0                         | 0    | 1     | 0 | 0                         | 0    | 0     | 0 | 0                         | 0    | 0     | 0 | 0                         | 0    | 0     | 0 | 1     | 49               |
| 4:15 PM                               | 0                         | 0    | 2     | 0 | 0                         | 0    | 0     | 0 | 0                         | 0    | 0     | 0 | 0                         | 0    | 0     | 0 | 2     | 49               |
| 4:20 PM                               | 0                         | 1    | 1     | 0 | 0                         | 0    | 0     | 0 | 0                         | 0    | 0     | 0 | 1                         | 1    | 0     | 0 | 4     | 48               |
| 4:25 PM                               | 0                         | 0    | 0     | 0 | 0                         | 0    | 0     | 0 | 1                         | 0    | 0     | 0 | 0                         | 0    | 0     | 0 | 1     | 44               |
| 4:30 PM                               | 1                         | 1    | 0     | 0 | 0                         | 0    | 0     | 0 | 0                         | 0    | 0     | 0 | 1                         | 0    | 0     | 0 | 3     | 42               |

**Attachment B**

| 5-Min Count Period Beginning At | Bimini Dr (Northbound) |      |       |   | Bimini Dr (Southbound) |      |       |   | Cambera Ln (Eastbound) |      |       |   | Cambera Ln (Westbound) |      |       |   | Total | Hourly Totals |
|---------------------------------|------------------------|------|-------|---|------------------------|------|-------|---|------------------------|------|-------|---|------------------------|------|-------|---|-------|---------------|
|                                 | Left                   | Thru | Right | U | Left                   | Thru | Right | U | Left                   | Thru | Right | U | Left                   | Thru | Right | U |       |               |
| 4:35 PM                         | 0                      | 1    | 0     | 0 | 0                      | 0    | 0     | 0 | 0                      | 0    | 0     | 0 | 2                      | 0    | 0     | 0 | 3     | 41            |
| 4:40 PM                         | 1                      | 0    | 0     | 0 | 0                      | 2    | 0     | 0 | 0                      | 0    | 0     | 0 | 0                      | 0    | 0     | 0 | 3     | 41            |
| 4:45 PM                         | 0                      | 0    | 0     | 0 | 0                      | 1    | 1     | 0 | 0                      | 0    | 0     | 0 | 1                      | 0    | 0     | 0 | 3     | 39            |
| 4:50 PM                         | 2                      | 0    | 0     | 0 | 0                      | 0    | 0     | 0 | 0                      | 0    | 2     | 0 | 0                      | 0    | 0     | 0 | 4     | 37            |
| 4:55 PM                         | 0                      | 0    | 0     | 0 | 0                      | 1    | 0     | 0 | 0                      | 0    | 0     | 0 | 0                      | 0    | 0     | 0 | 1     | 35            |
| 5:00 PM                         | 1                      | 0    | 0     | 0 | 0                      | 0    | 0     | 0 | 1                      | 0    | 1     | 0 | 0                      | 0    | 0     | 0 | 3     | 32            |
| 5:05 PM                         | 0                      | 1    | 0     | 0 | 0                      | 0    | 0     | 0 | 0                      | 0    | 0     | 0 | 0                      | 0    | 0     | 0 | 1     | 29            |
| 5:10 PM                         | 2                      | 0    | 4     | 0 | 0                      | 1    | 0     | 0 | 1                      | 0    | 0     | 0 | 0                      | 0    | 0     | 0 | 8     | 36            |
| 5:15 PM                         | 0                      | 1    | 0     | 0 | 0                      | 2    | 0     | 0 | 0                      | 0    | 0     | 0 | 2                      | 0    | 0     | 0 | 5     | 39            |
| 5:20 PM                         | 0                      | 1    | 0     | 0 | 0                      | 0    | 0     | 0 | 0                      | 0    | 0     | 0 | 0                      | 0    | 0     | 0 | 1     | 36            |
| 5:25 PM                         | 0                      | 1    | 1     | 0 | 0                      | 0    | 0     | 0 | 0                      | 0    | 0     | 0 | 0                      | 0    | 0     | 0 | 2     | 37            |
| 5:30 PM                         | 0                      | 0    | 1     | 0 | 0                      | 0    | 0     | 0 | 0                      | 0    | 2     | 0 | 0                      | 0    | 0     | 0 | 3     | 37            |
| 5:35 PM                         | 1                      | 0    | 0     | 0 | 0                      | 0    | 0     | 0 | 0                      | 0    | 0     | 0 | 0                      | 0    | 0     | 0 | 1     | 35            |
| 5:40 PM                         | 0                      | 1    | 1     | 0 | 0                      | 0    | 0     | 0 | 0                      | 0    | 0     | 0 | 0                      | 0    | 0     | 0 | 2     | 34            |
| 5:45 PM                         | 0                      | 0    | 1     | 0 | 0                      | 0    | 1     | 0 | 0                      | 0    | 1     | 0 | 0                      | 0    | 0     | 0 | 3     | 34            |
| 5:50 PM                         | 0                      | 0    | 0     | 0 | 0                      | 0    | 0     | 0 | 0                      | 0    | 1     | 0 | 1                      | 0    | 0     | 0 | 2     | 32            |
| 5:55 PM                         | 1                      | 1    | 0     | 0 | 0                      | 1    | 0     | 0 | 0                      | 0    | 0     | 0 | 0                      | 0    | 0     | 0 | 3     | 34            |
| 6:00 PM                         | 0                      | 1    | 0     | 0 | 0                      | 1    | 0     | 0 | 0                      | 0    | 0     | 0 | 0                      | 0    | 0     | 0 | 2     | 33            |
| 6:05 PM                         | 0                      | 1    | 0     | 0 | 0                      | 1    | 0     | 0 | 1                      | 0    | 1     | 0 | 0                      | 0    | 0     | 0 | 4     | 36            |
| 6:10 PM                         | 1                      | 0    | 1     | 0 | 0                      | 0    | 0     | 0 | 0                      | 0    | 0     | 0 | 1                      | 0    | 0     | 0 | 3     | 31            |
| 6:15 PM                         | 0                      | 1    | 1     | 0 | 0                      | 1    | 0     | 0 | 0                      | 0    | 0     | 0 | 1                      | 0    | 0     | 0 | 4     | 30            |
| 6:20 PM                         | 0                      | 0    | 1     | 0 | 0                      | 0    | 0     | 0 | 0                      | 0    | 1     | 0 | 1                      | 0    | 0     | 0 | 3     | 32            |
| 6:25 PM                         | 0                      | 0    | 0     | 0 | 0                      | 1    | 0     | 0 | 0                      | 0    | 0     | 0 | 1                      | 0    | 0     | 0 | 2     | 32            |
| 6:30 PM                         | 0                      | 1    | 0     | 0 | 1                      | 1    | 0     | 0 | 0                      | 0    | 0     | 0 | 2                      | 0    | 0     | 0 | 5     | 34            |
| 6:35 PM                         | 0                      | 1    | 1     | 0 | 0                      | 0    | 0     | 0 | 0                      | 0    | 0     | 0 | 0                      | 0    | 0     | 0 | 2     | 35            |
| 6:40 PM                         | 2                      | 1    | 1     | 0 | 0                      | 0    | 0     | 0 | 0                      | 0    | 0     | 0 | 0                      | 0    | 0     | 0 | 4     | 37            |
| 6:45 PM                         | 0                      | 0    | 0     | 0 | 0                      | 0    | 0     | 0 | 0                      | 0    | 0     | 0 | 0                      | 0    | 0     | 0 | 0     | 34            |
| 6:50 PM                         | 0                      | 0    | 0     | 0 | 0                      | 0    | 1     | 0 | 0                      | 0    | 0     | 0 | 1                      | 0    | 0     | 0 | 2     | 34            |
| 6:55 PM                         | 0                      | 2    | 0     | 0 | 0                      | 1    | 0     | 0 | 0                      | 0    | 0     | 0 | 0                      | 0    | 0     | 0 | 3     | 34            |
| 7:00 PM                         | 0                      | 0    | 0     | 0 | 0                      | 0    | 0     | 0 | 0                      | 0    | 0     | 0 | 1                      | 0    | 0     | 0 | 1     | 33            |
| 7:05 PM                         | 0                      | 1    | 1     | 0 | 0                      | 0    | 0     | 0 | 0                      | 0    | 0     | 0 | 0                      | 0    | 0     | 0 | 2     | 31            |
| 7:10 PM                         | 1                      | 0    | 0     | 0 | 0                      | 1    | 0     | 0 | 0                      | 0    | 0     | 0 | 0                      | 0    | 0     | 0 | 2     | 30            |
| 7:15 PM                         | 0                      | 0    | 2     | 0 | 0                      | 0    | 0     | 0 | 0                      | 0    | 0     | 0 | 0                      | 0    | 0     | 0 | 2     | 28            |
| 7:20 PM                         | 0                      | 1    | 0     | 0 | 0                      | 2    | 0     | 0 | 0                      | 0    | 0     | 0 | 0                      | 0    | 0     | 0 | 3     | 28            |
| 7:25 PM                         | 0                      | 1    | 1     | 0 | 0                      | 1    | 0     | 0 | 0                      | 0    | 1     | 0 | 2                      | 0    | 0     | 0 | 6     | 32            |
| 7:30 PM                         | 1                      | 1    | 0     | 0 | 0                      | 1    | 0     | 0 | 0                      | 0    | 0     | 0 | 0                      | 0    | 0     | 0 | 3     | 30            |
| 7:35 PM                         | 0                      | 0    | 0     | 0 | 0                      | 2    | 0     | 0 | 0                      | 0    | 0     | 0 | 0                      | 0    | 0     | 0 | 2     | 30            |
| 7:40 PM                         | 0                      | 0    | 2     | 0 | 0                      | 0    | 0     | 0 | 0                      | 0    | 0     | 0 | 0                      | 0    | 0     | 0 | 2     | 28            |
| 7:45 PM                         | 0                      | 2    | 0     | 0 | 0                      | 1    | 1     | 0 | 0                      | 0    | 0     | 0 | 0                      | 0    | 0     | 0 | 4     | 32            |
| 7:50 PM                         | 0                      | 0    | 1     | 0 | 0                      | 0    | 0     | 0 | 0                      | 0    | 0     | 0 | 0                      | 0    | 0     | 0 | 1     | 31            |
| 7:55 PM                         | 0                      | 0    | 0     | 0 | 0                      | 0    | 0     | 0 | 0                      | 0    | 0     | 0 | 0                      | 0    | 1     | 0 | 1     | 29            |
| 8:00 PM                         | 0                      | 0    | 0     | 0 | 0                      | 0    | 0     | 0 | 0                      | 0    | 0     | 0 | 0                      | 0    | 0     | 0 | 0     | 28            |
| 8:05 PM                         | 1                      | 0    | 1     | 0 | 0                      | 0    | 0     | 0 | 0                      | 0    | 0     | 0 | 0                      | 0    | 0     | 0 | 2     | 28            |
| 8:10 PM                         | 0                      | 0    | 0     | 0 | 1                      | 0    | 0     | 0 | 0                      | 0    | 0     | 0 | 1                      | 0    | 0     | 0 | 2     | 28            |
| 8:15 PM                         | 0                      | 1    | 0     | 0 | 0                      | 2    | 0     | 0 | 0                      | 0    | 0     | 0 | 0                      | 0    | 0     | 0 | 3     | 29            |
| 8:20 PM                         | 0                      | 1    | 1     | 0 | 0                      | 2    | 0     | 0 | 0                      | 0    | 0     | 0 | 0                      | 0    | 0     | 0 | 4     | 30            |
| 8:25 PM                         | 0                      | 0    | 1     | 0 | 0                      | 0    | 0     | 0 | 0                      | 0    | 0     | 0 | 0                      | 0    | 0     | 0 | 1     | 25            |
| 8:30 PM                         | 1                      | 0    | 0     | 0 | 0                      | 0    | 0     | 0 | 0                      | 0    | 0     | 0 | 0                      | 0    | 0     | 0 | 1     | 23            |
| 8:35 PM                         | 0                      | 0    | 0     | 0 | 0                      | 0    | 0     | 0 | 0                      | 0    | 0     | 0 | 0                      | 0    | 0     | 0 | 0     | 21            |
| 8:40 PM                         | 0                      | 0    | 0     | 0 | 0                      | 0    | 1     | 0 | 0                      | 0    | 0     | 0 | 1                      | 0    | 0     | 0 | 2     | 21            |
| 8:45 PM                         | 1                      | 0    | 2     | 0 | 0                      | 0    | 1     | 0 | 1                      | 0    | 0     | 0 | 0                      | 0    | 0     | 0 | 5     | 22            |
| 8:50 PM                         | 1                      | 2    | 1     | 0 | 0                      | 0    | 0     | 0 | 0                      | 0    | 0     | 0 | 0                      | 0    | 0     | 0 | 4     | 25            |
| 8:55 PM                         | 2                      | 0    | 0     | 0 | 0                      | 0    | 0     | 0 | 0                      | 0    | 1     | 0 | 0                      | 0    | 0     | 0 | 3     | 27            |
| 9:00 PM                         | 0                      | 1    | 1     | 0 | 0                      | 0    | 1     | 0 | 0                      | 0    | 0     | 0 | 1                      | 0    | 0     | 0 | 4     | 31            |
| 9:05 PM                         | 0                      | 1    | 0     | 0 | 0                      | 0    | 0     | 0 | 0                      | 0    | 0     | 0 | 0                      | 0    | 0     | 0 | 1     | 30            |
| 9:10 PM                         | 0                      | 1    | 1     | 0 | 0                      | 0    | 0     | 0 | 0                      | 0    | 0     | 0 | 0                      | 0    | 1     | 0 | 3     | 31            |
| 9:15 PM                         | 0                      | 0    | 0     | 0 | 0                      | 0    | 1     | 0 | 0                      | 0    | 0     | 0 | 0                      | 0    | 0     | 0 | 1     | 29            |
| 9:20 PM                         | 0                      | 0    | 0     | 0 | 0                      | 0    | 0     | 0 | 0                      | 0    | 1     | 0 | 1                      | 0    | 0     | 0 | 2     | 27            |
| 9:25 PM                         | 0                      | 1    | 0     | 0 | 0                      | 0    | 0     | 0 | 0                      | 0    | 0     | 0 | 0                      | 0    | 0     | 0 | 1     | 27            |
| 9:30 PM                         | 0                      | 0    | 1     | 0 | 0                      | 0    | 0     | 0 | 0                      | 0    | 0     | 0 | 0                      | 0    | 0     | 0 | 1     | 27            |
| 9:35 PM                         | 0                      | 0    | 0     | 0 | 0                      | 1    | 0     | 0 | 0                      | 0    | 0     | 0 | 0                      | 0    | 0     | 0 | 1     | 28            |
| 9:40 PM                         | 0                      | 0    | 2     | 0 | 0                      | 0    | 0     | 0 | 0                      | 0    | 0     | 0 | 0                      | 0    | 1     | 0 | 3     | 29            |
| 9:45 PM                         | 0                      | 0    | 1     | 0 | 0                      | 0    | 0     | 0 | 0                      | 0    | 0     | 0 | 0                      | 0    | 0     | 0 | 1     | 25            |
| 9:50 PM                         | 0                      | 0    | 0     | 0 | 0                      | 0    | 0     | 0 | 0                      | 0    | 0     | 0 | 0                      | 0    | 0     | 0 | 0     | 21            |
| 9:55 PM                         | 0                      | 1    | 0     | 0 | 0                      | 0    | 0     | 0 | 0                      | 0    | 0     | 0 | 0                      | 0    | 0     | 0 | 1     | 19            |
| Peak 15-Min Flowrates           | Northbound             |      |       |   | Southbound             |      |       |   | Eastbound              |      |       |   | Westbound              |      |       |   | Total |               |
|                                 | Left                   | Thru | Right | U | Left                   | Thru | Right | U | Left                   | Thru | Right | U | Left                   | Thru | Right | U |       |               |
| All Vehicles                    | 4                      | 32   | 8     | 0 | 0                      | 36   | 0     | 0 | 4                      | 0    | 12    | 0 | 20                     | 0    | 0     | 0 | 116   |               |
| Heavy Trucks                    | 0                      | 0    | 0     | 0 | 0                      | 0    | 0     | 0 | 0                      | 0    | 0     | 0 | 0                      | 0    | 0     | 0 | 0     |               |
| Buses                           |                        |      |       |   |                        |      |       |   |                        |      |       |   |                        |      |       |   |       |               |
| Pedestrians                     |                        | 0    |       |   |                        | 0    |       |   |                        | 0    |       |   |                        | 0    |       |   | 0     |               |
| Bicycles                        | 0                      | 0    | 0     |   | 0                      | 0    | 0     |   | 0                      | 0    | 0     |   | 0                      | 0    | 0     |   | 0     |               |
| Scoters                         |                        |      |       |   |                        |      |       |   |                        |      |       |   |                        |      |       |   |       |               |
| <i>Comments:</i>                |                        |      |       |   |                        |      |       |   |                        |      |       |   |                        |      |       |   |       |               |

LOCATION: Gigi Dr -- Smoke Tree Ln  
 CITY/STATE: North Tustin, CA

QC JOB #: 16966437  
 DATE: Thu, Apr 10 2025

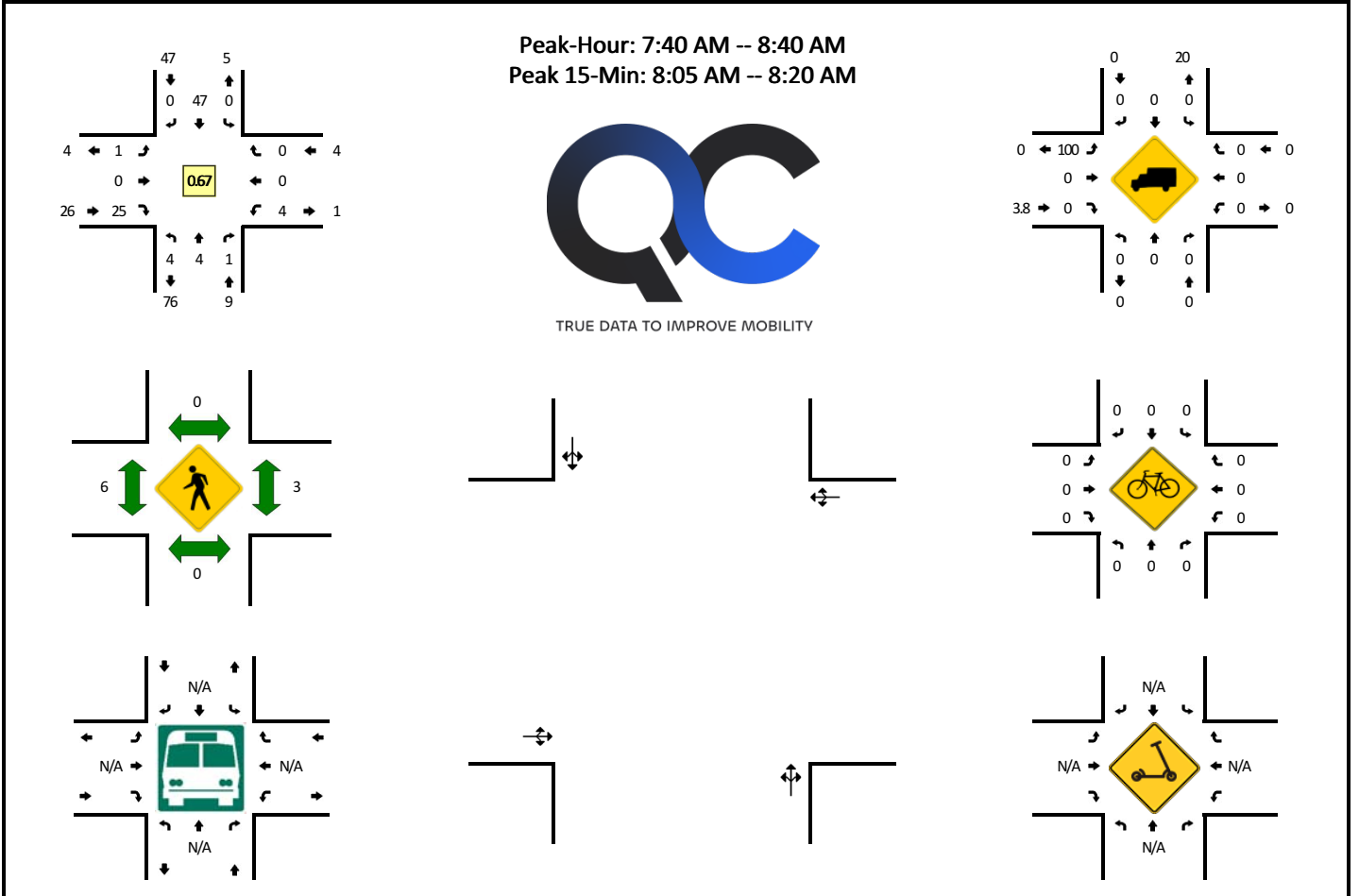

| 5-Min Count Period Beginning At | Gigi Dr (Northbound) |      |       |   | Gigi Dr (Southbound) |      |       |   | Smoke Tree Ln (Eastbound) |      |       |   | Smoke Tree Ln (Westbound) |      |       |   | Total | Hourly Totals |
|---------------------------------|----------------------|------|-------|---|----------------------|------|-------|---|---------------------------|------|-------|---|---------------------------|------|-------|---|-------|---------------|
|                                 | Left                 | Thru | Right | U | Left                 | Thru | Right | U | Left                      | Thru | Right | U | Left                      | Thru | Right | U |       |               |
| 6:00 AM                         | 0                    | 0    | 0     | 0 | 0                    | 0    | 0     | 0 | 0                         | 0    | 0     | 0 | 0                         | 0    | 0     | 0 | 0     |               |
| 6:05 AM                         | 0                    | 0    | 0     | 0 | 0                    | 0    | 0     | 0 | 0                         | 0    | 0     | 0 | 0                         | 0    | 0     | 0 | 0     |               |
| 6:10 AM                         | 0                    | 1    | 0     | 0 | 0                    | 0    | 0     | 0 | 0                         | 0    | 0     | 0 | 0                         | 0    | 0     | 0 | 1     |               |
| 6:15 AM                         | 0                    | 0    | 0     | 0 | 0                    | 0    | 0     | 0 | 0                         | 0    | 0     | 0 | 0                         | 0    | 0     | 0 | 0     |               |
| 6:20 AM                         | 0                    | 0    | 0     | 0 | 0                    | 0    | 0     | 0 | 1                         | 0    | 0     | 0 | 0                         | 0    | 0     | 0 | 1     |               |
| 6:25 AM                         | 0                    | 0    | 0     | 0 | 0                    | 0    | 0     | 0 | 0                         | 0    | 0     | 0 | 0                         | 0    | 0     | 0 | 0     |               |
| 6:30 AM                         | 0                    | 0    | 0     | 0 | 0                    | 1    | 0     | 0 | 0                         | 0    | 0     | 0 | 0                         | 0    | 0     | 0 | 1     |               |
| 6:35 AM                         | 0                    | 0    | 0     | 0 | 0                    | 1    | 0     | 0 | 0                         | 0    | 0     | 0 | 0                         | 0    | 0     | 0 | 1     |               |
| 6:40 AM                         | 0                    | 0    | 0     | 0 | 0                    | 1    | 0     | 0 | 0                         | 0    | 0     | 0 | 0                         | 0    | 0     | 0 | 1     |               |
| 6:45 AM                         | 0                    | 0    | 0     | 0 | 0                    | 0    | 0     | 0 | 0                         | 0    | 0     | 0 | 0                         | 0    | 0     | 0 | 0     |               |
| 6:50 AM                         | 0                    | 0    | 0     | 0 | 0                    | 0    | 0     | 0 | 0                         | 0    | 0     | 0 | 0                         | 0    | 0     | 0 | 0     |               |
| 6:55 AM                         | 0                    | 0    | 0     | 0 | 0                    | 1    | 0     | 0 | 0                         | 0    | 0     | 0 | 0                         | 0    | 0     | 0 | 1     |               |
| 7:00 AM                         | 0                    | 0    | 0     | 0 | 0                    | 0    | 0     | 0 | 0                         | 0    | 0     | 0 | 0                         | 0    | 0     | 0 | 0     |               |
| 7:05 AM                         | 1                    | 0    | 0     | 0 | 0                    | 2    | 0     | 0 | 0                         | 0    | 0     | 1 | 0                         | 0    | 0     | 0 | 4     |               |
| 7:10 AM                         | 0                    | 0    | 0     | 0 | 0                    | 5    | 0     | 0 | 0                         | 0    | 0     | 1 | 0                         | 0    | 0     | 0 | 6     |               |
| 7:15 AM                         | 0                    | 0    | 0     | 0 | 0                    | 6    | 0     | 0 | 0                         | 0    | 0     | 1 | 0                         | 0    | 0     | 0 | 7     |               |
| 7:20 AM                         | 0                    | 0    | 0     | 0 | 0                    | 1    | 0     | 0 | 0                         | 0    | 0     | 2 | 0                         | 0    | 0     | 0 | 3     |               |
| 7:25 AM                         | 0                    | 0    | 0     | 0 | 0                    | 1    | 0     | 0 | 0                         | 0    | 0     | 2 | 0                         | 0    | 0     | 0 | 3     |               |
| 7:30 AM                         | 0                    | 0    | 0     | 0 | 0                    | 1    | 0     | 0 | 0                         | 0    | 0     | 1 | 0                         | 0    | 0     | 0 | 2     |               |
| 7:35 AM                         | 0                    | 1    | 0     | 0 | 0                    | 1    | 0     | 0 | 0                         | 0    | 0     | 0 | 0                         | 0    | 0     | 0 | 2     |               |
| 7:40 AM                         | 0                    | 0    | 1     | 0 | 0                    | 6    | 0     | 0 | 0                         | 0    | 0     | 2 | 0                         | 0    | 0     | 0 | 9     |               |
| 7:45 AM                         | 0                    | 0    | 0     | 0 | 0                    | 0    | 0     | 0 | 0                         | 0    | 0     | 1 | 0                         | 0    | 0     | 0 | 1     |               |
| 7:50 AM                         | 0                    | 0    | 0     | 0 | 0                    | 4    | 0     | 0 | 0                         | 0    | 0     | 0 | 0                         | 0    | 0     | 0 | 4     |               |
| 7:55 AM                         | 0                    | 0    | 0     | 0 | 0                    | 4    | 0     | 0 | 0                         | 0    | 0     | 2 | 0                         | 0    | 0     | 0 | 6     |               |
| 8:00 AM                         | 3                    | 2    | 0     | 0 | 0                    | 4    | 0     | 0 | 0                         | 0    | 0     | 1 | 0                         | 1    | 0     | 0 | 11    |               |
| 8:05 AM                         | 0                    | 0    | 0     | 0 | 0                    | 10   | 0     | 0 | 0                         | 0    | 0     | 2 | 0                         | 1    | 0     | 0 | 13    |               |
| 8:10 AM                         | 0                    | 1    | 0     | 0 | 0                    | 5    | 0     | 0 | 0                         | 0    | 0     | 0 | 0                         | 1    | 0     | 0 | 7     |               |
| 8:15 AM                         | 1                    | 1    | 0     | 0 | 0                    | 6    | 0     | 0 | 0                         | 1    | 0     | 3 | 0                         | 0    | 0     | 0 | 12    |               |
| 8:20 AM                         | 0                    | 0    | 0     | 0 | 0                    | 5    | 0     | 0 | 0                         | 0    | 0     | 1 | 0                         | 1    | 0     | 0 | 7     |               |
| 8:25 AM                         | 0                    | 0    | 0     | 0 | 0                    | 1    | 0     | 0 | 0                         | 0    | 0     | 9 | 0                         | 0    | 0     | 0 | 10    |               |
| 8:30 AM                         | 0                    | 0    | 0     | 0 | 0                    | 1    | 0     | 0 | 0                         | 0    | 0     | 2 | 0                         | 0    | 0     | 0 | 3     |               |
| 8:35 AM                         | 0                    | 0    | 0     | 0 | 0                    | 1    | 0     | 0 | 0                         | 0    | 0     | 2 | 0                         | 0    | 0     | 0 | 3     |               |
| 8:40 AM                         | 0                    | 1    | 0     | 0 | 0                    | 0    | 0     | 0 | 0                         | 0    | 0     | 0 | 0                         | 0    | 0     | 0 | 1     |               |
| 8:45 AM                         | 0                    | 0    | 0     | 0 | 0                    | 0    | 0     | 0 | 0                         | 1    | 1     | 0 | 0                         | 0    | 0     | 0 | 2     |               |
| 8:50 AM                         | 0                    | 0    | 0     | 0 | 0                    | 0    | 0     | 0 | 0                         | 0    | 0     | 1 | 0                         | 0    | 0     | 0 | 1     |               |
| 8:55 AM                         | 0                    | 0    | 1     | 0 | 0                    | 1    | 0     | 0 | 0                         | 0    | 0     | 0 | 0                         | 1    | 0     | 0 | 3     |               |
| 9:00 AM                         | 0                    | 0    | 0     | 0 | 0                    | 2    | 0     | 0 | 0                         | 0    | 0     | 0 | 0                         | 0    | 0     | 0 | 2     |               |
| 9:05 AM                         | 0                    | 0    | 0     | 0 | 0                    | 4    | 0     | 0 | 0                         | 0    | 0     | 0 | 0                         | 0    | 0     | 0 | 4     |               |

Attachment B

| 5-Min Count Period Beginning At | Gigi Dr (Northbound) |      |       |   | Gigi Dr (Southbound) |      |       |   | Smoke Tree Ln (Eastbound) |      |       |   | Smoke Tree Ln (Westbound) |      |       |   | Total | Hourly Totals |    |
|---------------------------------|----------------------|------|-------|---|----------------------|------|-------|---|---------------------------|------|-------|---|---------------------------|------|-------|---|-------|---------------|----|
|                                 | Left                 | Thru | Right | U | Left                 | Thru | Right | U | Left                      | Thru | Right | U | Left                      | Thru | Right | U |       |               |    |
| 9:10 AM                         | 0                    | 0    | 0     | 0 | 0                    | 0    | 0     | 0 | 0                         | 0    | 0     | 0 | 0                         | 0    | 0     | 0 | 0     | 0             | 48 |
| 9:15 AM                         | 1                    | 0    | 0     | 0 | 0                    | 0    | 0     | 0 | 0                         | 0    | 0     | 0 | 0                         | 0    | 0     | 0 | 0     | 0             | 37 |
| 9:20 AM                         | 0                    | 1    | 0     | 0 | 0                    | 1    | 1     | 0 | 0                         | 1    | 0     | 0 | 0                         | 0    | 0     | 0 | 0     | 0             | 35 |
| 9:25 AM                         | 0                    | 0    | 0     | 0 | 0                    | 0    | 0     | 0 | 0                         | 0    | 1     | 0 | 0                         | 0    | 0     | 0 | 0     | 0             | 26 |
| 9:30 AM                         | 0                    | 0    | 1     | 0 | 0                    | 0    | 0     | 0 | 0                         | 0    | 0     | 0 | 0                         | 0    | 0     | 0 | 0     | 0             | 24 |
| 9:35 AM                         | 0                    | 0    | 0     | 0 | 0                    | 3    | 0     | 0 | 0                         | 0    | 1     | 0 | 0                         | 0    | 1     | 0 | 0     | 0             | 26 |
| 9:40 AM                         | 1                    | 0    | 0     | 0 | 0                    | 2    | 0     | 0 | 0                         | 0    | 0     | 2 | 0                         | 0    | 0     | 0 | 0     | 0             | 30 |
| 9:45 AM                         | 0                    | 0    | 0     | 0 | 0                    | 0    | 0     | 0 | 0                         | 0    | 0     | 3 | 0                         | 0    | 0     | 0 | 0     | 0             | 31 |
| 9:50 AM                         | 0                    | 0    | 0     | 0 | 0                    | 0    | 0     | 0 | 0                         | 0    | 0     | 0 | 0                         | 0    | 0     | 0 | 0     | 0             | 30 |
| 9:55 AM                         | 0                    | 1    | 0     | 0 | 0                    | 1    | 0     | 0 | 0                         | 0    | 0     | 0 | 0                         | 1    | 0     | 0 | 0     | 0             | 30 |
| 10:00 AM                        | 1                    | 0    | 0     | 0 | 0                    | 0    | 0     | 0 | 0                         | 0    | 0     | 0 | 0                         | 0    | 0     | 0 | 0     | 0             | 29 |
| 10:05 AM                        | 0                    | 0    | 0     | 0 | 0                    | 1    | 0     | 0 | 0                         | 0    | 0     | 0 | 0                         | 0    | 0     | 0 | 0     | 0             | 26 |
| 10:10 AM                        | 0                    | 0    | 0     | 0 | 0                    | 3    | 0     | 0 | 0                         | 0    | 0     | 0 | 0                         | 0    | 0     | 0 | 0     | 0             | 29 |
| 10:15 AM                        | 0                    | 2    | 0     | 0 | 0                    | 2    | 0     | 0 | 0                         | 0    | 0     | 0 | 0                         | 0    | 0     | 0 | 0     | 0             | 32 |
| 10:20 AM                        | 0                    | 0    | 0     | 0 | 0                    | 0    | 0     | 0 | 0                         | 0    | 0     | 0 | 0                         | 2    | 0     | 0 | 0     | 0             | 29 |
| 10:25 AM                        | 0                    | 1    | 0     | 0 | 0                    | 0    | 0     | 0 | 0                         | 0    | 0     | 3 | 0                         | 0    | 0     | 0 | 0     | 0             | 32 |
| 10:30 AM                        | 0                    | 0    | 0     | 0 | 0                    | 0    | 0     | 0 | 0                         | 0    | 0     | 1 | 0                         | 0    | 0     | 0 | 0     | 0             | 32 |
| 10:35 AM                        | 0                    | 0    | 0     | 0 | 0                    | 0    | 0     | 0 | 0                         | 0    | 0     | 0 | 0                         | 0    | 0     | 0 | 0     | 0             | 27 |
| 10:40 AM                        | 0                    | 0    | 0     | 0 | 0                    | 0    | 0     | 0 | 0                         | 0    | 0     | 0 | 0                         | 0    | 0     | 0 | 0     | 0             | 22 |
| 10:45 AM                        | 0                    | 0    | 0     | 0 | 0                    | 1    | 0     | 0 | 0                         | 0    | 1     | 0 | 0                         | 0    | 0     | 0 | 0     | 0             | 21 |
| 10:50 AM                        | 0                    | 1    | 0     | 0 | 0                    | 0    | 0     | 0 | 0                         | 0    | 0     | 0 | 0                         | 0    | 0     | 0 | 0     | 0             | 22 |
| 10:55 AM                        | 0                    | 1    | 1     | 0 | 0                    | 2    | 0     | 0 | 0                         | 0    | 0     | 0 | 0                         | 0    | 0     | 0 | 0     | 0             | 23 |
| 11:00 AM                        | 0                    | 0    | 0     | 0 | 0                    | 0    | 0     | 0 | 0                         | 0    | 1     | 0 | 0                         | 0    | 0     | 0 | 0     | 0             | 23 |
| 11:05 AM                        | 0                    | 0    | 0     | 0 | 0                    | 0    | 0     | 0 | 0                         | 0    | 0     | 1 | 0                         | 1    | 0     | 0 | 0     | 0             | 24 |
| 11:10 AM                        | 0                    | 0    | 0     | 0 | 0                    | 0    | 0     | 0 | 0                         | 0    | 0     | 0 | 0                         | 0    | 0     | 0 | 0     | 0             | 21 |
| 11:15 AM                        | 0                    | 0    | 0     | 0 | 0                    | 2    | 0     | 0 | 0                         | 1    | 0     | 1 | 0                         | 0    | 0     | 0 | 0     | 0             | 21 |
| 11:20 AM                        | 0                    | 0    | 0     | 0 | 0                    | 1    | 0     | 0 | 0                         | 0    | 0     | 0 | 0                         | 0    | 0     | 0 | 0     | 0             | 20 |
| 11:25 AM                        | 0                    | 0    | 0     | 0 | 0                    | 3    | 0     | 0 | 0                         | 0    | 0     | 1 | 0                         | 0    | 0     | 0 | 0     | 0             | 20 |
| 11:30 AM                        | 0                    | 0    | 0     | 0 | 0                    | 1    | 0     | 0 | 0                         | 0    | 0     | 0 | 0                         | 1    | 0     | 0 | 0     | 0             | 21 |
| 11:35 AM                        | 1                    | 0    | 0     | 0 | 0                    | 0    | 0     | 0 | 0                         | 0    | 1     | 0 | 0                         | 0    | 0     | 1 | 0     | 0             | 24 |
| 11:40 AM                        | 0                    | 1    | 1     | 0 | 0                    | 0    | 0     | 0 | 0                         | 0    | 0     | 0 | 0                         | 0    | 0     | 0 | 0     | 0             | 26 |
| 11:45 AM                        | 1                    | 0    | 0     | 0 | 0                    | 2    | 0     | 0 | 0                         | 0    | 0     | 1 | 0                         | 0    | 0     | 0 | 0     | 0             | 28 |
| 11:50 AM                        | 0                    | 0    | 0     | 0 | 0                    | 2    | 0     | 0 | 0                         | 0    | 2     | 0 | 0                         | 0    | 1     | 0 | 0     | 0             | 32 |
| 11:55 AM                        | 0                    | 1    | 0     | 0 | 0                    | 2    | 0     | 0 | 0                         | 0    | 0     | 0 | 0                         | 0    | 0     | 0 | 0     | 0             | 31 |
| 12:00 PM                        | 0                    | 0    | 0     | 0 | 0                    | 0    | 0     | 0 | 0                         | 0    | 0     | 0 | 0                         | 0    | 0     | 0 | 0     | 0             | 30 |
| 12:05 PM                        | 0                    | 0    | 0     | 0 | 0                    | 1    | 0     | 0 | 0                         | 0    | 0     | 0 | 0                         | 1    | 0     | 0 | 0     | 0             | 30 |
| 12:10 PM                        | 0                    | 1    | 1     | 0 | 0                    | 2    | 0     | 0 | 0                         | 0    | 0     | 0 | 0                         | 0    | 0     | 0 | 0     | 0             | 34 |
| 12:15 PM                        | 0                    | 1    | 0     | 0 | 0                    | 2    | 0     | 0 | 0                         | 0    | 0     | 0 | 0                         | 0    | 0     | 0 | 0     | 0             | 33 |
| 12:20 PM                        | 0                    | 2    | 0     | 0 | 0                    | 2    | 0     | 0 | 0                         | 0    | 0     | 0 | 0                         | 0    | 0     | 0 | 0     | 0             | 36 |
| 12:25 PM                        | 0                    | 0    | 0     | 0 | 0                    | 1    | 0     | 0 | 0                         | 0    | 0     | 0 | 0                         | 0    | 0     | 0 | 0     | 0             | 33 |
| 12:30 PM                        | 0                    | 1    | 1     | 0 | 0                    | 1    | 0     | 0 | 0                         | 0    | 0     | 0 | 0                         | 0    | 0     | 0 | 0     | 0             | 34 |
| 12:35 PM                        | 0                    | 0    | 0     | 0 | 0                    | 0    | 0     | 0 | 0                         | 0    | 0     | 0 | 0                         | 0    | 0     | 0 | 0     | 0             | 31 |
| 12:40 PM                        | 0                    | 0    | 0     | 0 | 0                    | 3    | 0     | 0 | 0                         | 0    | 1     | 0 | 0                         | 0    | 0     | 0 | 0     | 0             | 33 |
| 12:45 PM                        | 0                    | 2    | 0     | 0 | 0                    | 1    | 0     | 0 | 0                         | 0    | 0     | 1 | 0                         | 0    | 1     | 0 | 0     | 0             | 34 |
| 12:50 PM                        | 1                    | 1    | 0     | 0 | 0                    | 1    | 0     | 0 | 0                         | 0    | 0     | 0 | 0                         | 0    | 0     | 0 | 0     | 0             | 32 |
| 12:55 PM                        | 0                    | 0    | 0     | 0 | 0                    | 0    | 0     | 0 | 0                         | 0    | 0     | 0 | 0                         | 0    | 0     | 0 | 0     | 0             | 29 |
| 1:00 PM                         | 0                    | 0    | 0     | 0 | 0                    | 1    | 0     | 0 | 0                         | 0    | 0     | 0 | 0                         | 0    | 0     | 0 | 0     | 0             | 30 |
| 1:05 PM                         | 1                    | 0    | 0     | 0 | 0                    | 1    | 0     | 0 | 0                         | 0    | 0     | 1 | 0                         | 0    | 0     | 0 | 0     | 0             | 31 |
| 1:10 PM                         | 0                    | 0    | 0     | 0 | 0                    | 0    | 0     | 0 | 0                         | 0    | 0     | 2 | 0                         | 0    | 0     | 0 | 0     | 0             | 29 |
| 1:15 PM                         | 0                    | 1    | 0     | 0 | 0                    | 1    | 0     | 0 | 0                         | 0    | 0     | 0 | 0                         | 0    | 0     | 0 | 0     | 0             | 28 |
| 1:20 PM                         | 1                    | 0    | 0     | 0 | 0                    | 1    | 0     | 0 | 0                         | 0    | 0     | 0 | 0                         | 0    | 0     | 0 | 0     | 0             | 26 |
| 1:25 PM                         | 1                    | 2    | 0     | 0 | 0                    | 0    | 0     | 0 | 0                         | 1    | 0     | 0 | 0                         | 0    | 0     | 0 | 0     | 0             | 29 |
| 1:30 PM                         | 0                    | 1    | 0     | 0 | 0                    | 1    | 0     | 0 | 0                         | 0    | 0     | 0 | 0                         | 0    | 0     | 0 | 0     | 0             | 28 |
| 1:35 PM                         | 2                    | 0    | 0     | 0 | 0                    | 0    | 0     | 0 | 0                         | 0    | 0     | 1 | 0                         | 0    | 0     | 0 | 0     | 0             | 32 |
| 1:40 PM                         | 0                    | 0    | 0     | 0 | 0                    | 0    | 0     | 0 | 0                         | 0    | 0     | 0 | 0                         | 0    | 0     | 0 | 0     | 0             | 28 |
| 1:45 PM                         | 1                    | 1    | 0     | 0 | 0                    | 0    | 0     | 0 | 0                         | 0    | 0     | 0 | 0                         | 0    | 0     | 0 | 0     | 0             | 25 |
| 1:50 PM                         | 0                    | 1    | 0     | 0 | 0                    | 1    | 0     | 0 | 0                         | 0    | 0     | 0 | 0                         | 0    | 0     | 0 | 0     | 0             | 24 |
| 1:55 PM                         | 0                    | 0    | 0     | 0 | 0                    | 1    | 0     | 0 | 0                         | 1    | 0     | 0 | 0                         | 0    | 0     | 0 | 0     | 0             | 26 |
| 2:00 PM                         | 0                    | 0    | 0     | 0 | 0                    | 3    | 0     | 0 | 0                         | 0    | 0     | 0 | 0                         | 1    | 0     | 1 | 0     | 0             | 30 |
| 2:05 PM                         | 0                    | 1    | 0     | 0 | 0                    | 0    | 0     | 0 | 0                         | 0    | 0     | 0 | 0                         | 0    | 0     | 0 | 0     | 0             | 28 |
| 2:10 PM                         | 0                    | 1    | 0     | 0 | 0                    | 0    | 0     | 0 | 0                         | 0    | 0     | 1 | 0                         | 1    | 0     | 0 | 0     | 0             | 29 |
| 2:15 PM                         | 1                    | 0    | 1     | 0 | 0                    | 0    | 0     | 0 | 0                         | 0    | 0     | 1 | 0                         | 0    | 0     | 0 | 0     | 0             | 30 |
| 2:20 PM                         | 0                    | 1    | 0     | 0 | 0                    | 1    | 1     | 0 | 0                         | 0    | 1     | 0 | 0                         | 0    | 0     | 0 | 0     | 0             | 32 |
| 2:25 PM                         | 0                    | 2    | 1     | 0 | 0                    | 1    | 0     | 0 | 0                         | 0    | 0     | 1 | 0                         | 0    | 0     | 0 | 0     | 0             | 33 |
| 2:30 PM                         | 0                    | 0    | 0     | 0 | 0                    | 1    | 0     | 0 | 0                         | 0    | 0     | 0 | 0                         | 0    | 0     | 0 | 0     | 0             | 32 |
| 2:35 PM                         | 1                    | 2    | 0     | 0 | 0                    | 2    | 0     | 0 | 0                         | 0    | 0     | 0 | 0                         | 0    | 0     | 0 | 0     | 0             | 33 |
| 2:40 PM                         | 0                    | 1    | 0     | 0 | 0                    | 1    | 0     | 0 | 0                         | 0    | 1     | 0 | 0                         | 0    | 0     | 0 | 0     | 0             | 36 |
| 2:45 PM                         | 0                    | 2    | 0     | 0 | 0                    | 6    | 0     | 0 | 0                         | 0    | 0     | 0 | 0                         | 0    | 0     | 0 | 0     | 0             | 42 |
| 2:50 PM                         | 2                    | 1    | 0     | 0 | 0                    | 7    | 0     | 0 | 0                         | 0    | 0     | 0 | 0                         | 0    | 1     | 0 | 0     | 0             | 51 |
| 2:55 PM                         | 1                    | 2    | 0     | 0 | 0                    | 1    | 0     | 0 | 0                         | 0    | 1     | 0 | 0                         | 0    | 0     | 0 | 0     | 0             | 54 |
| 3:00 PM                         | 0                    | 2    | 0     | 0 | 0                    | 1    | 0     | 0 | 0                         | 0    | 0     | 0 | 0                         | 0    | 0     | 0 | 0     | 0             | 52 |
| 3:05 PM                         | 0                    | 0    | 1     | 0 | 0                    | 1    | 0     | 0 | 0                         | 0    | 0     | 1 | 0                         | 0    | 0     | 0 | 0     | 0             | 54 |
| 3:10 PM                         | 0                    | 1    | 0     | 0 | 0                    | 3    | 0     | 0 | 0                         | 0    | 0     | 0 | 0                         | 0    | 0     | 0 | 0     | 0             | 55 |
| 3:15 PM                         | 0                    | 1    | 0     | 0 | 0                    | 2    | 0     | 0 | 0                         | 0    | 0     | 1 | 0                         | 0    | 0     | 0 | 0     | 0             | 56 |
| 3:20 PM                         | 0                    | 0    | 0     | 0 | 0                    | 1    | 0     | 0 | 0                         | 0    | 0     | 0 | 0                         | 0    | 0     | 0 | 0     | 0             | 53 |
| 3:25 PM                         | 0                    | 1    | 0     | 0 | 0                    | 1    | 0     | 0 | 0                         | 0    | 0     | 1 | 0                         | 0    | 0     | 0 | 0     | 0             | 51 |
| 3:30 PM                         | 0                    | 1    | 0     | 0 | 0                    | 1    | 0     | 0 | 0                         | 0    | 0     | 0 | 0                         | 1    | 0     | 0 | 0     | 0             | 53 |
| 3:35 PM                         | 0                    | 3    | 0     | 0 | 1                    | 1    | 0     | 0 | 0                         | 0    | 1     | 0 | 0                         | 1    | 0     | 0 | 0     | 0             | 55 |
| 3:40 PM                         | 0                    | 1    | 1     | 0 | 0                    | 2    | 0     | 0 | 0                         | 0    | 0     | 1 | 0                         | 0    | 0     | 0 | 0     | 0             | 57 |
| 3:45 PM                         | 0                    | 0    | 0     | 0 | 0                    | 1    | 0     | 0 | 0                         | 0    | 0     | 1 | 0                         | 0    | 0     | 0 | 0     | 0             | 51 |
| 3:50 PM                         | 1                    | 0    | 0     | 0 | 0                    | 1    | 1     | 0 | 0                         | 0    | 0     | 1 | 0                         | 0    | 0     | 0 | 0     | 0             | 44 |
| 3:55 PM                         | 0                    | 1    | 0     | 0 | 0                    | 3    | 1     | 0 | 0                         | 1    | 0     | 1 | 0                         | 0    | 0     | 0 | 0     | 0             | 46 |
| 4:00 PM                         | 0                    | 1    | 0     | 0 | 0                    | 0    | 0     | 0 | 0                         | 0    | 0     | 1 | 0                         | 0    | 0     | 0 | 0     | 0             | 45 |
| 4:05 PM                         | 0                    | 0    | 1     | 0 | 0                    | 1    | 0     | 0 | 0                         | 0    | 1     | 0 | 0                         | 0    | 0     | 0 | 0     | 0             | 45 |
| 4:10 PM                         | 0                    | 0    | 0     | 0 | 0                    | 1    | 0     | 0 | 0                         | 0    | 0     | 0 | 0                         | 1    | 0     | 0 | 0     | 0             | 43 |
| 4:15 PM                         | 1                    | 0    | 0     | 0 | 0                    | 0    | 0     | 0 | 0                         | 0    | 0     | 3 | 0                         | 1    | 0     | 0 | 0     | 0             | 44 |
| 4:20 PM                         | 0                    | 0    | 0     | 0 | 0                    | 2    | 0     | 0 | 0                         | 0    | 0     | 1 | 0                         | 0    | 0     | 0 | 0     | 0             | 46 |
| 4:25 PM                         | 0                    | 0    | 0     | 0 | 0                    | 1    | 0     | 0 | 0                         | 0    | 0     | 0 | 0                         | 0    | 0     | 0 | 0     | 0             | 44 |
| 4:30 PM                         | 0                    | 1    | 0     | 0 | 0                    | 1    | 0     | 0 | 0                         | 0    | 0     | 1 | 0                         | 1    | 0     | 0 | 0     | 0             | 45 |

**Attachment B**

| 5-Min Count Period Beginning At | Gigi Dr (Northbound) |      |       |   | Gigi Dr (Southbound) |      |       |   | Smoke Tree Ln (Eastbound) |      |       |   | Smoke Tree Ln (Westbound) |      |       |   | Total | Hourly Totals |    |
|---------------------------------|----------------------|------|-------|---|----------------------|------|-------|---|---------------------------|------|-------|---|---------------------------|------|-------|---|-------|---------------|----|
|                                 | Left                 | Thru | Right | U | Left                 | Thru | Right | U | Left                      | Thru | Right | U | Left                      | Thru | Right | U |       |               |    |
| 4:35 PM                         | 1                    | 0    | 1     | 0 | 0                    | 1    | 0     | 0 | 0                         | 0    | 0     | 0 | 0                         | 1    | 0     | 0 | 0     | 4             | 42 |
| 4:40 PM                         | 1                    | 3    | 0     | 0 | 0                    | 0    | 0     | 0 | 0                         | 0    | 0     | 0 | 0                         | 0    | 0     | 0 | 0     | 4             | 41 |
| 4:45 PM                         | 0                    | 1    | 0     | 0 | 0                    | 1    | 0     | 0 | 0                         | 0    | 0     | 0 | 0                         | 0    | 0     | 0 | 0     | 2             | 41 |
| 4:50 PM                         | 0                    | 0    | 0     | 0 | 0                    | 2    | 0     | 0 | 0                         | 0    | 1     | 0 | 0                         | 0    | 0     | 0 | 0     | 3             | 40 |
| 4:55 PM                         | 0                    | 0    | 1     | 0 | 0                    | 0    | 0     | 0 | 0                         | 0    | 0     | 0 | 0                         | 0    | 0     | 0 | 0     | 1             | 34 |
| 5:00 PM                         | 0                    | 2    | 0     | 0 | 0                    | 1    | 1     | 0 | 0                         | 0    | 0     | 0 | 0                         | 0    | 0     | 0 | 0     | 4             | 36 |
| 5:05 PM                         | 0                    | 2    | 0     | 0 | 0                    | 0    | 0     | 0 | 0                         | 0    | 0     | 1 | 0                         | 1    | 0     | 0 | 0     | 4             | 37 |
| 5:10 PM                         | 0                    | 2    | 0     | 0 | 0                    | 2    | 0     | 0 | 0                         | 0    | 0     | 1 | 0                         | 0    | 0     | 0 | 0     | 5             | 40 |
| 5:15 PM                         | 0                    | 2    | 0     | 0 | 0                    | 2    | 0     | 0 | 0                         | 0    | 1     | 2 | 0                         | 1    | 0     | 0 | 0     | 8             | 43 |
| 5:20 PM                         | 0                    | 1    | 0     | 0 | 0                    | 0    | 0     | 0 | 0                         | 0    | 0     | 0 | 0                         | 0    | 0     | 0 | 0     | 1             | 41 |
| 5:25 PM                         | 0                    | 1    | 0     | 0 | 0                    | 2    | 0     | 0 | 0                         | 0    | 0     | 0 | 0                         | 0    | 0     | 0 | 0     | 3             | 43 |
| 5:30 PM                         | 0                    | 1    | 0     | 0 | 0                    | 1    | 1     | 0 | 0                         | 0    | 0     | 1 | 0                         | 0    | 0     | 0 | 0     | 4             | 43 |
| 5:35 PM                         | 0                    | 0    | 0     | 0 | 0                    | 1    | 0     | 0 | 0                         | 0    | 1     | 0 | 0                         | 0    | 0     | 0 | 0     | 2             | 41 |
| 5:40 PM                         | 0                    | 1    | 0     | 0 | 0                    | 1    | 0     | 0 | 0                         | 0    | 0     | 1 | 0                         | 0    | 0     | 0 | 0     | 3             | 40 |
| 5:45 PM                         | 1                    | 0    | 0     | 0 | 0                    | 0    | 0     | 0 | 0                         | 1    | 0     | 0 | 0                         | 1    | 0     | 0 | 0     | 3             | 41 |
| 5:50 PM                         | 1                    | 2    | 0     | 0 | 0                    | 0    | 0     | 0 | 0                         | 0    | 0     | 1 | 0                         | 0    | 0     | 0 | 0     | 4             | 42 |
| 5:55 PM                         | 1                    | 0    | 0     | 0 | 0                    | 1    | 0     | 0 | 0                         | 0    | 0     | 0 | 0                         | 0    | 0     | 0 | 0     | 2             | 43 |
| 6:00 PM                         | 1                    | 0    | 0     | 0 | 0                    | 1    | 0     | 0 | 0                         | 0    | 0     | 2 | 0                         | 0    | 0     | 0 | 0     | 4             | 43 |
| 6:05 PM                         | 0                    | 2    | 1     | 0 | 0                    | 1    | 0     | 0 | 0                         | 0    | 0     | 0 | 0                         | 0    | 0     | 0 | 0     | 4             | 43 |
| 6:10 PM                         | 0                    | 0    | 0     | 0 | 0                    | 0    | 1     | 0 | 0                         | 0    | 0     | 0 | 0                         | 0    | 0     | 0 | 0     | 1             | 39 |
| 6:15 PM                         | 0                    | 2    | 0     | 0 | 0                    | 2    | 0     | 0 | 0                         | 0    | 0     | 0 | 0                         | 0    | 0     | 0 | 0     | 4             | 35 |
| 6:20 PM                         | 0                    | 0    | 0     | 0 | 0                    | 1    | 0     | 0 | 0                         | 0    | 0     | 1 | 0                         | 0    | 0     | 0 | 0     | 2             | 36 |
| 6:25 PM                         | 0                    | 0    | 0     | 0 | 0                    | 0    | 0     | 0 | 0                         | 0    | 0     | 1 | 0                         | 0    | 0     | 0 | 0     | 1             | 34 |
| 6:30 PM                         | 1                    | 0    | 0     | 0 | 0                    | 3    | 0     | 0 | 0                         | 0    | 0     | 1 | 0                         | 0    | 0     | 0 | 0     | 5             | 35 |
| 6:35 PM                         | 0                    | 1    | 0     | 0 | 0                    | 1    | 0     | 0 | 0                         | 0    | 0     | 0 | 0                         | 0    | 0     | 0 | 0     | 2             | 35 |
| 6:40 PM                         | 0                    | 1    | 0     | 0 | 0                    | 2    | 0     | 0 | 0                         | 0    | 0     | 0 | 0                         | 0    | 0     | 0 | 0     | 3             | 35 |
| 6:45 PM                         | 0                    | 0    | 0     | 0 | 0                    | 0    | 0     | 0 | 0                         | 0    | 0     | 3 | 0                         | 0    | 0     | 0 | 0     | 3             | 35 |
| 6:50 PM                         | 1                    | 0    | 0     | 0 | 0                    | 0    | 0     | 0 | 0                         | 0    | 0     | 0 | 0                         | 0    | 0     | 0 | 0     | 1             | 32 |
| 6:55 PM                         | 0                    | 1    | 0     | 0 | 0                    | 0    | 0     | 0 | 0                         | 0    | 0     | 1 | 0                         | 0    | 0     | 0 | 0     | 2             | 32 |
| 7:00 PM                         | 0                    | 0    | 0     | 0 | 0                    | 1    | 0     | 0 | 0                         | 0    | 0     | 1 | 0                         | 0    | 0     | 0 | 0     | 2             | 30 |
| 7:05 PM                         | 0                    | 1    | 0     | 0 | 0                    | 0    | 0     | 0 | 0                         | 0    | 0     | 0 | 0                         | 0    | 0     | 0 | 0     | 1             | 27 |
| 7:10 PM                         | 1                    | 0    | 1     | 0 | 0                    | 0    | 0     | 0 | 0                         | 0    | 0     | 1 | 0                         | 0    | 0     | 0 | 0     | 3             | 29 |
| 7:15 PM                         | 0                    | 1    | 0     | 0 | 0                    | 2    | 0     | 0 | 0                         | 1    | 0     | 0 | 0                         | 0    | 0     | 0 | 0     | 4             | 29 |
| 7:20 PM                         | 0                    | 1    | 0     | 0 | 0                    | 1    | 0     | 0 | 0                         | 0    | 0     | 0 | 0                         | 0    | 0     | 0 | 0     | 2             | 29 |
| 7:25 PM                         | 0                    | 2    | 0     | 0 | 0                    | 1    | 0     | 0 | 0                         | 0    | 0     | 1 | 0                         | 0    | 0     | 0 | 0     | 4             | 32 |
| 7:30 PM                         | 1                    | 0    | 0     | 0 | 0                    | 1    | 0     | 0 | 0                         | 0    | 0     | 0 | 0                         | 0    | 0     | 0 | 0     | 2             | 29 |
| 7:35 PM                         | 0                    | 0    | 0     | 0 | 0                    | 1    | 0     | 0 | 0                         | 0    | 0     | 0 | 0                         | 0    | 0     | 0 | 0     | 1             | 28 |
| 7:40 PM                         | 0                    | 0    | 0     | 0 | 0                    | 1    | 0     | 0 | 0                         | 0    | 0     | 0 | 0                         | 1    | 0     | 0 | 0     | 2             | 27 |
| 7:45 PM                         | 0                    | 1    | 0     | 0 | 0                    | 1    | 0     | 0 | 0                         | 0    | 0     | 0 | 0                         | 0    | 0     | 0 | 0     | 2             | 26 |
| 7:50 PM                         | 0                    | 0    | 0     | 0 | 0                    | 1    | 0     | 0 | 0                         | 0    | 0     | 0 | 0                         | 0    | 0     | 0 | 0     | 1             | 26 |
| 7:55 PM                         | 0                    | 0    | 0     | 0 | 0                    | 0    | 0     | 0 | 0                         | 0    | 0     | 0 | 0                         | 0    | 0     | 0 | 0     | 0             | 24 |
| 8:00 PM                         | 0                    | 0    | 0     | 0 | 0                    | 0    | 0     | 0 | 0                         | 0    | 0     | 0 | 0                         | 0    | 0     | 0 | 0     | 0             | 22 |
| 8:05 PM                         | 0                    | 0    | 0     | 0 | 0                    | 0    | 0     | 0 | 0                         | 0    | 0     | 1 | 0                         | 0    | 0     | 0 | 0     | 1             | 22 |
| 8:10 PM                         | 1                    | 2    | 1     | 0 | 0                    | 1    | 0     | 0 | 0                         | 0    | 0     | 0 | 0                         | 0    | 0     | 0 | 0     | 5             | 24 |
| 8:15 PM                         | 0                    | 1    | 0     | 0 | 0                    | 0    | 0     | 0 | 0                         | 0    | 0     | 0 | 0                         | 0    | 0     | 0 | 0     | 1             | 21 |
| 8:20 PM                         | 0                    | 2    | 0     | 0 | 0                    | 0    | 0     | 0 | 0                         | 0    | 0     | 0 | 0                         | 0    | 0     | 0 | 0     | 2             | 21 |
| 8:25 PM                         | 0                    | 0    | 0     | 0 | 0                    | 1    | 0     | 0 | 0                         | 0    | 0     | 0 | 0                         | 0    | 0     | 0 | 0     | 1             | 18 |
| 8:30 PM                         | 0                    | 0    | 0     | 0 | 0                    | 0    | 0     | 0 | 0                         | 0    | 0     | 0 | 0                         | 0    | 0     | 0 | 0     | 0             | 16 |
| 8:35 PM                         | 0                    | 0    | 0     | 0 | 0                    | 0    | 0     | 0 | 0                         | 0    | 0     | 0 | 0                         | 0    | 0     | 0 | 0     | 0             | 15 |
| 8:40 PM                         | 0                    | 0    | 0     | 0 | 0                    | 1    | 0     | 0 | 0                         | 0    | 0     | 0 | 0                         | 0    | 0     | 0 | 0     | 1             | 14 |
| 8:45 PM                         | 0                    | 0    | 0     | 0 | 0                    | 1    | 0     | 0 | 0                         | 0    | 0     | 1 | 0                         | 0    | 0     | 0 | 0     | 2             | 14 |
| 8:50 PM                         | 0                    | 0    | 1     | 0 | 0                    | 1    | 0     | 0 | 0                         | 0    | 0     | 0 | 0                         | 0    | 0     | 0 | 0     | 2             | 15 |
| 8:55 PM                         | 0                    | 0    | 0     | 0 | 0                    | 0    | 0     | 0 | 0                         | 0    | 0     | 0 | 0                         | 0    | 0     | 0 | 0     | 0             | 15 |
| 9:00 PM                         | 1                    | 1    | 0     | 0 | 0                    | 0    | 0     | 0 | 0                         | 0    | 0     | 0 | 0                         | 0    | 0     | 0 | 0     | 2             | 17 |
| 9:05 PM                         | 0                    | 0    | 0     | 0 | 0                    | 0    | 0     | 0 | 0                         | 0    | 0     | 0 | 0                         | 0    | 0     | 0 | 0     | 0             | 16 |
| 9:10 PM                         | 1                    | 1    | 0     | 0 | 0                    | 0    | 0     | 0 | 0                         | 0    | 0     | 0 | 0                         | 0    | 0     | 0 | 0     | 2             | 13 |
| 9:15 PM                         | 1                    | 1    | 0     | 0 | 0                    | 0    | 0     | 0 | 0                         | 0    | 0     | 0 | 0                         | 0    | 0     | 0 | 0     | 2             | 14 |
| 9:20 PM                         | 0                    | 1    | 0     | 0 | 0                    | 1    | 0     | 0 | 0                         | 0    | 0     | 1 | 0                         | 0    | 0     | 0 | 0     | 3             | 15 |
| 9:25 PM                         | 0                    | 0    | 0     | 0 | 0                    | 1    | 0     | 0 | 0                         | 0    | 0     | 0 | 0                         | 0    | 0     | 0 | 0     | 1             | 15 |
| 9:30 PM                         | 0                    | 0    | 0     | 0 | 0                    | 0    | 0     | 0 | 0                         | 0    | 0     | 0 | 0                         | 0    | 0     | 0 | 0     | 0             | 15 |
| 9:35 PM                         | 0                    | 0    | 0     | 0 | 0                    | 0    | 0     | 0 | 0                         | 0    | 0     | 1 | 0                         | 0    | 0     | 0 | 0     | 1             | 16 |
| 9:40 PM                         | 0                    | 1    | 0     | 0 | 0                    | 1    | 0     | 0 | 0                         | 0    | 0     | 0 | 0                         | 0    | 0     | 0 | 0     | 2             | 17 |
| 9:45 PM                         | 0                    | 0    | 0     | 0 | 0                    | 0    | 0     | 0 | 0                         | 0    | 0     | 0 | 0                         | 0    | 0     | 0 | 0     | 0             | 15 |
| 9:50 PM                         | 0                    | 0    | 0     | 0 | 0                    | 0    | 0     | 0 | 0                         | 0    | 0     | 0 | 0                         | 0    | 0     | 0 | 0     | 0             | 13 |
| 9:55 PM                         | 0                    | 1    | 0     | 0 | 0                    | 0    | 0     | 0 | 0                         | 0    | 0     | 0 | 0                         | 0    | 0     | 0 | 0     | 1             | 14 |
| Peak 15-Min Flowrates           | Northbound           |      |       |   | Southbound           |      |       |   | Eastbound                 |      |       |   | Westbound                 |      |       |   | Total |               |    |
|                                 | Left                 | Thru | Right | U | Left                 | Thru | Right | U | Left                      | Thru | Right | U | Left                      | Thru | Right | U |       |               |    |
| All Vehicles                    | 4                    | 8    | 0     | 0 | 0                    | 84   | 0     | 0 | 4                         | 0    | 20    | 0 | 8                         | 0    | 0     | 0 | 128   |               |    |
| Heavy Trucks                    | 0                    | 0    | 0     |   | 0                    | 0    | 0     |   | 4                         | 0    | 0     |   | 0                         | 0    | 0     |   | 4     |               |    |
| Buses                           |                      |      |       |   |                      |      |       |   |                           |      |       |   |                           |      |       |   |       |               |    |
| Pedestrians                     |                      | 0    |       |   |                      | 0    |       |   |                           | 12   |       |   |                           | 4    |       |   | 16    |               |    |
| Bicycles                        | 0                    | 0    | 0     |   | 0                    | 0    | 0     |   | 0                         | 0    | 0     |   | 0                         | 0    | 0     |   | 0     |               |    |
| Scoters                         |                      |      |       |   |                      |      |       |   |                           |      |       |   |                           |      |       |   |       |               |    |
| <i>Comments:</i>                |                      |      |       |   |                      |      |       |   |                           |      |       |   |                           |      |       |   |       |               |    |

Type of peak hour being reported: Intersection Peak

Method for determining peak hour: Total Entering Volume

LOCATION: Vista Mar -- Racquet Hill  
 CITY/STATE: North Tustin, CA

QC JOB #: 16966438  
 DATE: Thu, Apr 10 2025

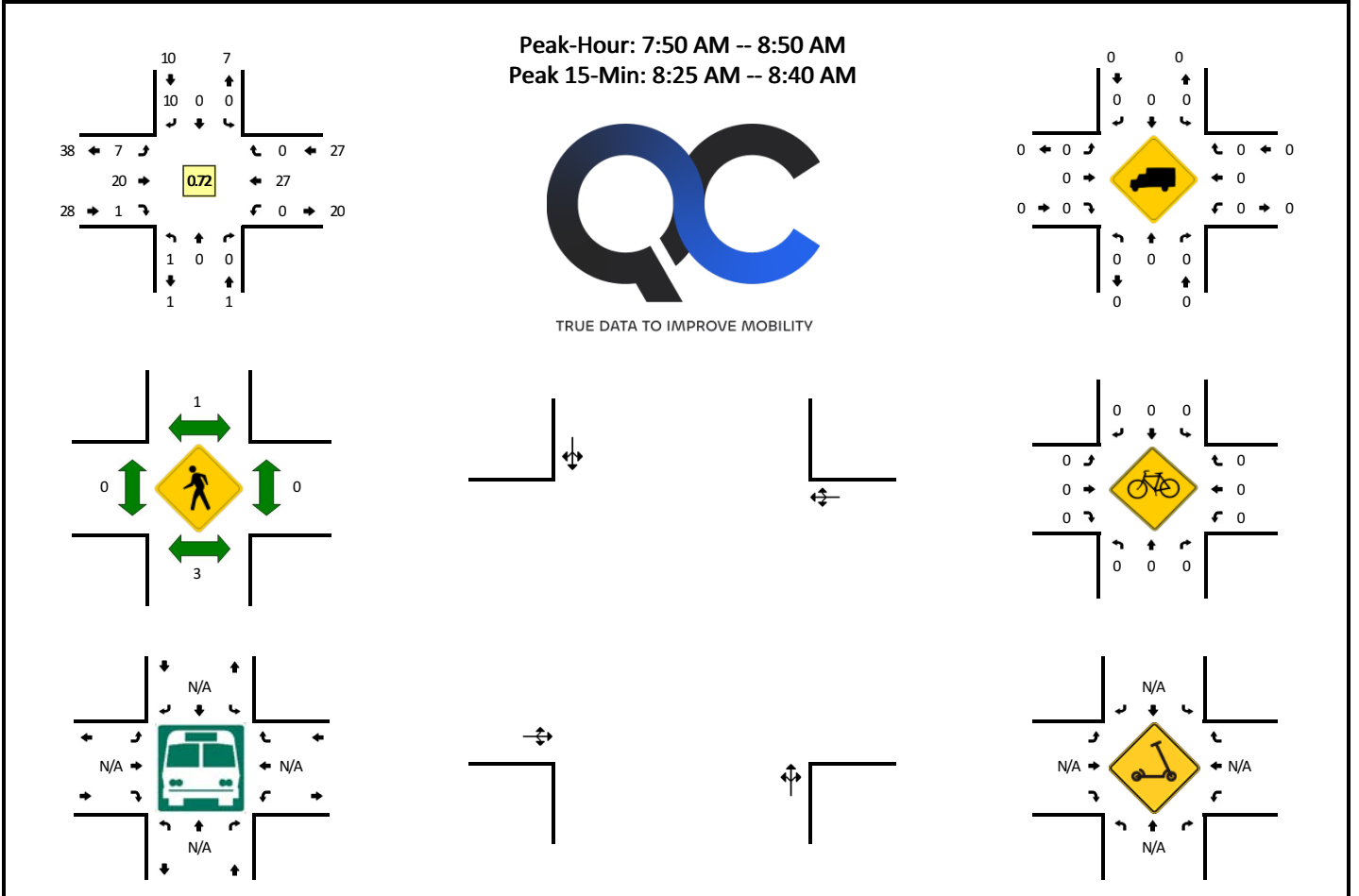

| 5-Min Count Period Beginning At | Vista Mar (Northbound) |      |       |   | Vista Mar (Southbound) |      |       |   | Racquet Hill (Eastbound) |      |       |   | Racquet Hill (Westbound) |      |       |   | Total | Hourly Totals |    |
|---------------------------------|------------------------|------|-------|---|------------------------|------|-------|---|--------------------------|------|-------|---|--------------------------|------|-------|---|-------|---------------|----|
|                                 | Left                   | Thru | Right | U | Left                   | Thru | Right | U | Left                     | Thru | Right | U | Left                     | Thru | Right | U |       |               |    |
| 6:00 AM                         | 0                      | 0    | 0     | 0 | 0                      | 0    | 0     | 0 | 0                        | 0    | 0     | 0 | 0                        | 1    | 0     | 0 | 0     | 1             |    |
| 6:05 AM                         | 0                      | 0    | 0     | 0 | 0                      | 0    | 0     | 0 | 0                        | 0    | 0     | 0 | 0                        | 0    | 0     | 0 | 0     | 0             |    |
| 6:10 AM                         | 0                      | 0    | 0     | 0 | 0                      | 0    | 1     | 0 | 0                        | 0    | 0     | 0 | 0                        | 2    | 0     | 0 | 0     | 3             |    |
| 6:15 AM                         | 0                      | 0    | 0     | 0 | 0                      | 0    | 0     | 0 | 0                        | 0    | 0     | 0 | 0                        | 0    | 0     | 0 | 0     | 0             |    |
| 6:20 AM                         | 1                      | 0    | 0     | 0 | 0                      | 0    | 0     | 0 | 0                        | 0    | 0     | 0 | 0                        | 0    | 0     | 0 | 0     | 1             |    |
| 6:25 AM                         | 0                      | 0    | 0     | 0 | 0                      | 0    | 0     | 0 | 0                        | 0    | 0     | 0 | 0                        | 2    | 0     | 0 | 0     | 2             |    |
| 6:30 AM                         | 0                      | 0    | 0     | 0 | 0                      | 0    | 0     | 0 | 0                        | 0    | 0     | 0 | 0                        | 0    | 0     | 0 | 0     | 0             |    |
| 6:35 AM                         | 0                      | 0    | 1     | 0 | 0                      | 0    | 0     | 0 | 0                        | 0    | 1     | 0 | 0                        | 0    | 1     | 0 | 0     | 3             |    |
| 6:40 AM                         | 0                      | 0    | 0     | 0 | 0                      | 0    | 0     | 0 | 0                        | 0    | 1     | 0 | 0                        | 0    | 0     | 0 | 0     | 1             |    |
| 6:45 AM                         | 0                      | 0    | 0     | 0 | 0                      | 0    | 0     | 0 | 0                        | 0    | 2     | 0 | 0                        | 0    | 1     | 0 | 0     | 3             |    |
| 6:50 AM                         | 0                      | 0    | 0     | 0 | 0                      | 0    | 0     | 0 | 0                        | 0    | 0     | 1 | 0                        | 0    | 0     | 0 | 0     | 1             |    |
| 6:55 AM                         | 0                      | 0    | 0     | 0 | 0                      | 0    | 1     | 0 | 0                        | 0    | 0     | 0 | 0                        | 1    | 0     | 0 | 0     | 2             | 17 |
| 7:00 AM                         | 0                      | 0    | 0     | 0 | 0                      | 0    | 0     | 0 | 0                        | 0    | 0     | 0 | 0                        | 1    | 0     | 0 | 0     | 1             | 17 |
| 7:05 AM                         | 0                      | 0    | 0     | 0 | 0                      | 0    | 0     | 0 | 0                        | 0    | 0     | 0 | 0                        | 1    | 0     | 0 | 0     | 1             | 18 |
| 7:10 AM                         | 0                      | 0    | 0     | 0 | 0                      | 0    | 0     | 0 | 0                        | 0    | 0     | 0 | 0                        | 1    | 0     | 0 | 0     | 1             | 16 |
| 7:15 AM                         | 0                      | 0    | 0     | 0 | 0                      | 0    | 0     | 0 | 0                        | 0    | 0     | 0 | 0                        | 2    | 0     | 0 | 0     | 2             | 18 |
| 7:20 AM                         | 0                      | 0    | 0     | 0 | 0                      | 0    | 1     | 0 | 0                        | 0    | 2     | 0 | 0                        | 0    | 0     | 0 | 0     | 3             | 20 |
| 7:25 AM                         | 0                      | 0    | 0     | 0 | 0                      | 0    | 1     | 0 | 0                        | 0    | 1     | 0 | 0                        | 0    | 3     | 0 | 0     | 5             | 23 |
| 7:30 AM                         | 0                      | 0    | 0     | 0 | 0                      | 0    | 0     | 0 | 0                        | 0    | 1     | 0 | 0                        | 0    | 0     | 0 | 0     | 1             | 24 |
| 7:35 AM                         | 0                      | 0    | 0     | 0 | 0                      | 0    | 1     | 0 | 0                        | 0    | 2     | 0 | 0                        | 0    | 1     | 0 | 0     | 4             | 25 |
| 7:40 AM                         | 0                      | 0    | 0     | 0 | 0                      | 0    | 1     | 0 | 0                        | 0    | 1     | 0 | 0                        | 0    | 3     | 0 | 0     | 5             | 29 |
| 7:45 AM                         | 0                      | 0    | 0     | 0 | 0                      | 0    | 1     | 0 | 0                        | 0    | 1     | 0 | 0                        | 0    | 1     | 0 | 0     | 3             | 29 |
| 7:50 AM                         | 1                      | 0    | 0     | 0 | 0                      | 0    | 1     | 0 | 0                        | 0    | 0     | 0 | 0                        | 5    | 0     | 0 | 0     | 7             | 35 |
| 7:55 AM                         | 0                      | 0    | 0     | 0 | 0                      | 0    | 0     | 0 | 0                        | 0    | 1     | 0 | 0                        | 6    | 0     | 0 | 0     | 7             | 40 |
| 8:00 AM                         | 0                      | 0    | 0     | 0 | 0                      | 0    | 0     | 0 | 0                        | 0    | 3     | 0 | 0                        | 1    | 0     | 0 | 0     | 4             | 43 |
| 8:05 AM                         | 0                      | 0    | 0     | 0 | 0                      | 0    | 0     | 0 | 0                        | 1    | 0     | 0 | 0                        | 3    | 0     | 0 | 0     | 4             | 46 |
| 8:10 AM                         | 0                      | 0    | 0     | 0 | 0                      | 0    | 3     | 0 | 0                        | 1    | 2     | 0 | 0                        | 0    | 0     | 0 | 0     | 6             | 51 |
| 8:15 AM                         | 0                      | 0    | 0     | 0 | 0                      | 0    | 1     | 0 | 0                        | 0    | 1     | 0 | 0                        | 0    | 0     | 0 | 0     | 2             | 51 |
| 8:20 AM                         | 0                      | 0    | 0     | 0 | 0                      | 0    | 0     | 0 | 0                        | 0    | 2     | 0 | 0                        | 0    | 0     | 0 | 0     | 2             | 50 |
| 8:25 AM                         | 0                      | 0    | 0     | 0 | 0                      | 0    | 0     | 0 | 0                        | 1    | 2     | 0 | 0                        | 0    | 3     | 0 | 0     | 6             | 51 |
| 8:30 AM                         | 0                      | 0    | 0     | 0 | 0                      | 0    | 2     | 0 | 0                        | 2    | 4     | 0 | 0                        | 0    | 2     | 0 | 0     | 10            | 60 |
| 8:35 AM                         | 0                      | 0    | 0     | 0 | 0                      | 0    | 0     | 0 | 0                        | 1    | 3     | 0 | 0                        | 0    | 3     | 0 | 0     | 7             | 63 |
| 8:40 AM                         | 0                      | 0    | 0     | 0 | 0                      | 0    | 2     | 0 | 0                        | 0    | 0     | 1 | 0                        | 0    | 2     | 0 | 0     | 5             | 63 |
| 8:45 AM                         | 0                      | 0    | 0     | 0 | 0                      | 0    | 1     | 0 | 0                        | 1    | 2     | 0 | 0                        | 0    | 2     | 0 | 0     | 6             | 66 |
| 8:50 AM                         | 0                      | 0    | 0     | 0 | 0                      | 0    | 2     | 0 | 0                        | 0    | 1     | 0 | 0                        | 0    | 1     | 0 | 0     | 4             | 63 |
| 8:55 AM                         | 0                      | 0    | 1     | 0 | 0                      | 0    | 0     | 0 | 0                        | 1    | 1     | 1 | 0                        | 1    | 1     | 0 | 0     | 6             | 62 |
| 9:00 AM                         | 0                      | 0    | 0     | 0 | 0                      | 0    | 1     | 0 | 0                        | 0    | 0     | 0 | 0                        | 0    | 0     | 0 | 0     | 1             | 59 |
| 9:05 AM                         | 0                      | 0    | 0     | 0 | 0                      | 0    | 0     | 0 | 0                        | 0    | 3     | 0 | 0                        | 0    | 0     | 0 | 0     | 3             | 58 |

**Attachment B**

| 5-Min Count Period Beginning At | Vista Mar (Northbound) |      |       |   | Vista Mar (Southbound) |      |       |   | Racquet Hill (Eastbound) |      |       |   | Racquet Hill (Westbound) |      |       |   | Total | Hourly Totals |
|---------------------------------|------------------------|------|-------|---|------------------------|------|-------|---|--------------------------|------|-------|---|--------------------------|------|-------|---|-------|---------------|
|                                 | Left                   | Thru | Right | U | Left                   | Thru | Right | U | Left                     | Thru | Right | U | Left                     | Thru | Right | U |       |               |
| 9:10 AM                         | 0                      | 0    | 0     | 0 | 0                      | 0    | 2     | 0 | 0                        | 0    | 0     | 0 | 0                        | 1    | 0     | 0 | 3     | 55            |
| 9:15 AM                         | 0                      | 0    | 0     | 0 | 0                      | 0    | 1     | 0 | 1                        | 3    | 1     | 0 | 0                        | 0    | 1     | 0 | 7     | 60            |
| 9:20 AM                         | 0                      | 0    | 0     | 0 | 0                      | 0    | 1     | 0 | 1                        | 3    | 0     | 0 | 0                        | 0    | 2     | 0 | 7     | 65            |
| 9:25 AM                         | 0                      | 0    | 0     | 0 | 0                      | 0    | 1     | 0 | 0                        | 1    | 0     | 0 | 0                        | 0    | 2     | 0 | 4     | 63            |
| 9:30 AM                         | 0                      | 0    | 0     | 0 | 0                      | 0    | 0     | 0 | 0                        | 2    | 0     | 0 | 0                        | 0    | 3     | 0 | 5     | 58            |
| 9:35 AM                         | 1                      | 0    | 0     | 0 | 0                      | 0    | 0     | 0 | 1                        | 0    | 1     | 0 | 0                        | 0    | 2     | 0 | 5     | 56            |
| 9:40 AM                         | 0                      | 0    | 0     | 0 | 0                      | 0    | 0     | 0 | 0                        | 0    | 0     | 0 | 0                        | 0    | 1     | 0 | 1     | 52            |
| 9:45 AM                         | 0                      | 0    | 1     | 0 | 0                      | 0    | 1     | 0 | 0                        | 1    | 1     | 0 | 0                        | 0    | 2     | 0 | 6     | 52            |
| 9:50 AM                         | 0                      | 0    | 0     | 0 | 0                      | 0    | 0     | 0 | 0                        | 2    | 0     | 0 | 0                        | 0    | 2     | 0 | 4     | 52            |
| 9:55 AM                         | 0                      | 0    | 0     | 0 | 0                      | 0    | 0     | 0 | 0                        | 5    | 0     | 0 | 0                        | 0    | 2     | 0 | 7     | 53            |
| 10:00 AM                        | 0                      | 0    | 0     | 0 | 0                      | 0    | 0     | 0 | 1                        | 0    | 0     | 0 | 0                        | 0    | 2     | 0 | 3     | 55            |
| 10:05 AM                        | 0                      | 0    | 0     | 0 | 0                      | 0    | 1     | 0 | 0                        | 1    | 0     | 0 | 0                        | 0    | 0     | 0 | 2     | 54            |
| 10:10 AM                        | 0                      | 0    | 0     | 0 | 0                      | 0    | 0     | 0 | 0                        | 1    | 0     | 0 | 0                        | 0    | 1     | 0 | 2     | 53            |
| 10:15 AM                        | 0                      | 0    | 0     | 0 | 0                      | 0    | 0     | 0 | 1                        | 1    | 0     | 0 | 0                        | 0    | 1     | 1 | 4     | 50            |
| 10:20 AM                        | 0                      | 0    | 0     | 0 | 0                      | 0    | 0     | 0 | 1                        | 2    | 0     | 0 | 0                        | 0    | 1     | 0 | 4     | 47            |
| 10:25 AM                        | 0                      | 0    | 1     | 0 | 0                      | 0    | 0     | 0 | 1                        | 1    | 1     | 0 | 0                        | 0    | 0     | 0 | 4     | 47            |
| 10:30 AM                        | 0                      | 0    | 0     | 0 | 0                      | 0    | 0     | 0 | 1                        | 0    | 0     | 0 | 0                        | 0    | 0     | 0 | 1     | 43            |
| 10:35 AM                        | 1                      | 0    | 0     | 0 | 0                      | 0    | 1     | 0 | 0                        | 0    | 0     | 0 | 0                        | 0    | 0     | 0 | 2     | 40            |
| 10:40 AM                        | 0                      | 0    | 0     | 0 | 0                      | 0    | 1     | 0 | 0                        | 0    | 0     | 0 | 0                        | 0    | 0     | 0 | 1     | 40            |
| 10:45 AM                        | 0                      | 0    | 0     | 0 | 0                      | 0    | 0     | 0 | 0                        | 1    | 0     | 0 | 0                        | 0    | 2     | 0 | 3     | 37            |
| 10:50 AM                        | 0                      | 0    | 0     | 0 | 0                      | 0    | 0     | 0 | 2                        | 0    | 0     | 0 | 0                        | 0    | 1     | 0 | 3     | 36            |
| 10:55 AM                        | 0                      | 0    | 1     | 0 | 0                      | 0    | 1     | 0 | 0                        | 2    | 0     | 0 | 0                        | 0    | 4     | 0 | 8     | 37            |
| 11:00 AM                        | 0                      | 0    | 0     | 0 | 0                      | 0    | 0     | 0 | 0                        | 0    | 0     | 0 | 0                        | 0    | 2     | 0 | 2     | 36            |
| 11:05 AM                        | 0                      | 0    | 0     | 0 | 0                      | 0    | 0     | 0 | 0                        | 0    | 0     | 0 | 0                        | 0    | 1     | 0 | 1     | 35            |
| 11:10 AM                        | 0                      | 0    | 0     | 0 | 0                      | 0    | 0     | 0 | 1                        | 0    | 0     | 0 | 0                        | 0    | 0     | 0 | 1     | 34            |
| 11:15 AM                        | 0                      | 0    | 0     | 0 | 0                      | 0    | 0     | 0 | 2                        | 2    | 0     | 0 | 0                        | 0    | 1     | 0 | 5     | 35            |
| 11:20 AM                        | 0                      | 0    | 0     | 0 | 0                      | 0    | 0     | 0 | 0                        | 0    | 0     | 0 | 0                        | 0    | 2     | 0 | 2     | 33            |
| 11:25 AM                        | 1                      | 0    | 0     | 0 | 0                      | 0    | 1     | 0 | 0                        | 3    | 1     | 0 | 0                        | 0    | 0     | 0 | 6     | 35            |
| 11:30 AM                        | 0                      | 0    | 0     | 0 | 1                      | 0    | 1     | 0 | 2                        | 3    | 0     | 0 | 0                        | 0    | 1     | 0 | 8     | 42            |
| 11:35 AM                        | 0                      | 0    | 0     | 0 | 0                      | 0    | 1     | 0 | 1                        | 1    | 0     | 0 | 0                        | 0    | 0     | 0 | 3     | 43            |
| 11:40 AM                        | 0                      | 0    | 0     | 0 | 0                      | 0    | 0     | 0 | 2                        | 3    | 1     | 0 | 0                        | 0    | 1     | 0 | 7     | 49            |
| 11:45 AM                        | 0                      | 0    | 0     | 0 | 0                      | 0    | 1     | 0 | 1                        | 1    | 0     | 0 | 0                        | 0    | 4     | 0 | 7     | 53            |
| 11:50 AM                        | 0                      | 0    | 0     | 0 | 0                      | 0    | 0     | 0 | 0                        | 1    | 0     | 0 | 0                        | 0    | 2     | 0 | 3     | 53            |
| 11:55 AM                        | 1                      | 0    | 0     | 0 | 0                      | 0    | 0     | 0 | 0                        | 0    | 0     | 0 | 0                        | 0    | 3     | 0 | 4     | 49            |
| 12:00 PM                        | 1                      | 0    | 0     | 0 | 0                      | 0    | 0     | 0 | 0                        | 1    | 0     | 0 | 0                        | 0    | 1     | 0 | 3     | 50            |
| 12:05 PM                        | 0                      | 0    | 0     | 0 | 0                      | 0    | 2     | 0 | 1                        | 0    | 0     | 0 | 0                        | 0    | 1     | 0 | 4     | 53            |
| 12:10 PM                        | 0                      | 0    | 0     | 0 | 0                      | 0    | 0     | 0 | 0                        | 0    | 1     | 0 | 0                        | 0    | 0     | 0 | 1     | 53            |
| 12:15 PM                        | 0                      | 0    | 1     | 0 | 0                      | 0    | 0     | 0 | 0                        | 0    | 0     | 0 | 0                        | 0    | 1     | 0 | 2     | 50            |
| 12:20 PM                        | 0                      | 0    | 0     | 0 | 0                      | 0    | 0     | 0 | 1                        | 2    | 0     | 0 | 0                        | 0    | 1     | 0 | 4     | 52            |
| 12:25 PM                        | 0                      | 0    | 0     | 0 | 0                      | 0    | 0     | 0 | 0                        | 1    | 0     | 0 | 0                        | 0    | 1     | 0 | 2     | 48            |
| 12:30 PM                        | 0                      | 0    | 0     | 0 | 0                      | 0    | 0     | 0 | 2                        | 2    | 0     | 0 | 0                        | 0    | 1     | 0 | 5     | 45            |
| 12:35 PM                        | 0                      | 0    | 0     | 0 | 0                      | 0    | 0     | 0 | 1                        | 3    | 0     | 0 | 0                        | 0    | 1     | 1 | 6     | 48            |
| 12:40 PM                        | 0                      | 0    | 0     | 0 | 0                      | 0    | 3     | 0 | 0                        | 0    | 0     | 0 | 0                        | 0    | 1     | 0 | 4     | 45            |
| 12:45 PM                        | 0                      | 0    | 0     | 0 | 0                      | 0    | 0     | 0 | 0                        | 1    | 0     | 0 | 0                        | 0    | 1     | 0 | 2     | 40            |
| 12:50 PM                        | 0                      | 0    | 0     | 0 | 0                      | 0    | 0     | 0 | 0                        | 0    | 0     | 0 | 0                        | 0    | 2     | 0 | 2     | 39            |
| 12:55 PM                        | 0                      | 0    | 0     | 0 | 0                      | 0    | 0     | 0 | 1                        | 3    | 0     | 0 | 0                        | 0    | 2     | 0 | 6     | 41            |
| 1:00 PM                         | 0                      | 0    | 0     | 0 | 0                      | 0    | 0     | 0 | 2                        | 1    | 0     | 0 | 0                        | 0    | 1     | 0 | 4     | 42            |
| 1:05 PM                         | 0                      | 0    | 0     | 0 | 1                      | 0    | 2     | 0 | 2                        | 1    | 0     | 0 | 0                        | 0    | 1     | 0 | 7     | 45            |
| 1:10 PM                         | 0                      | 0    | 0     | 0 | 0                      | 0    | 0     | 0 | 0                        | 0    | 0     | 0 | 0                        | 0    | 3     | 0 | 3     | 47            |
| 1:15 PM                         | 0                      | 0    | 0     | 0 | 0                      | 0    | 1     | 0 | 0                        | 1    | 1     | 0 | 0                        | 0    | 3     | 0 | 6     | 51            |
| 1:20 PM                         | 0                      | 0    | 0     | 0 | 0                      | 0    | 1     | 0 | 0                        | 2    | 0     | 0 | 0                        | 0    | 0     | 0 | 3     | 50            |
| 1:25 PM                         | 0                      | 0    | 0     | 0 | 0                      | 0    | 0     | 0 | 0                        | 1    | 0     | 0 | 0                        | 0    | 1     | 0 | 2     | 50            |
| 1:30 PM                         | 0                      | 0    | 0     | 0 | 0                      | 0    | 2     | 0 | 0                        | 0    | 0     | 0 | 0                        | 0    | 2     | 0 | 4     | 49            |
| 1:35 PM                         | 0                      | 0    | 0     | 0 | 0                      | 0    | 1     | 0 | 0                        | 3    | 0     | 0 | 0                        | 0    | 1     | 0 | 5     | 48            |
| 1:40 PM                         | 0                      | 0    | 0     | 0 | 0                      | 0    | 0     | 0 | 0                        | 1    | 0     | 0 | 0                        | 0    | 1     | 0 | 2     | 46            |
| 1:45 PM                         | 1                      | 0    | 0     | 0 | 0                      | 0    | 0     | 0 | 0                        | 0    | 0     | 0 | 0                        | 0    | 2     | 0 | 3     | 47            |
| 1:50 PM                         | 0                      | 0    | 0     | 0 | 0                      | 0    | 1     | 0 | 0                        | 1    | 0     | 0 | 0                        | 0    | 1     | 0 | 3     | 48            |
| 1:55 PM                         | 0                      | 0    | 0     | 0 | 0                      | 0    | 0     | 0 | 0                        | 2    | 0     | 0 | 0                        | 0    | 2     | 0 | 4     | 46            |
| 2:00 PM                         | 0                      | 0    | 1     | 0 | 0                      | 0    | 0     | 0 | 1                        | 0    | 1     | 0 | 0                        | 0    | 2     | 0 | 5     | 47            |
| 2:05 PM                         | 0                      | 0    | 0     | 0 | 0                      | 0    | 0     | 0 | 0                        | 0    | 1     | 0 | 0                        | 0    | 0     | 0 | 1     | 41            |
| 2:10 PM                         | 0                      | 1    | 0     | 0 | 1                      | 0    | 1     | 0 | 0                        | 2    | 0     | 0 | 0                        | 0    | 2     | 0 | 7     | 45            |
| 2:15 PM                         | 0                      | 0    | 0     | 0 | 0                      | 0    | 0     | 0 | 0                        | 1    | 0     | 0 | 0                        | 0    | 1     | 0 | 2     | 41            |
| 2:20 PM                         | 0                      | 0    | 0     | 0 | 0                      | 0    | 1     | 0 | 0                        | 4    | 1     | 0 | 0                        | 0    | 3     | 0 | 9     | 47            |
| 2:25 PM                         | 0                      | 0    | 0     | 0 | 0                      | 0    | 0     | 0 | 1                        | 1    | 0     | 0 | 0                        | 0    | 1     | 0 | 3     | 48            |
| 2:30 PM                         | 1                      | 0    | 0     | 0 | 0                      | 0    | 0     | 0 | 0                        | 1    | 0     | 0 | 0                        | 0    | 1     | 1 | 4     | 48            |
| 2:35 PM                         | 0                      | 0    | 0     | 0 | 0                      | 0    | 0     | 0 | 1                        | 1    | 0     | 0 | 0                        | 0    | 1     | 0 | 3     | 46            |
| 2:40 PM                         | 0                      | 0    | 0     | 0 | 0                      | 0    | 2     | 0 | 0                        | 0    | 0     | 0 | 0                        | 0    | 1     | 0 | 3     | 47            |
| 2:45 PM                         | 0                      | 0    | 1     | 0 | 0                      | 0    | 1     | 0 | 0                        | 2    | 1     | 0 | 0                        | 0    | 2     | 0 | 7     | 51            |
| 2:50 PM                         | 0                      | 0    | 0     | 0 | 0                      | 0    | 0     | 0 | 2                        | 2    | 0     | 0 | 0                        | 0    | 2     | 0 | 6     | 54            |
| 2:55 PM                         | 0                      | 0    | 0     | 0 | 0                      | 0    | 1     | 0 | 1                        | 5    | 0     | 0 | 0                        | 0    | 2     | 0 | 9     | 59            |
| 3:00 PM                         | 0                      | 0    | 0     | 0 | 0                      | 0    | 0     | 0 | 1                        | 3    | 0     | 0 | 0                        | 0    | 1     | 0 | 5     | 59            |
| 3:05 PM                         | 0                      | 0    | 0     | 0 | 0                      | 0    | 0     | 0 | 0                        | 1    | 1     | 0 | 0                        | 0    | 1     | 0 | 3     | 61            |
| 3:10 PM                         | 0                      | 0    | 0     | 0 | 0                      | 0    | 0     | 0 | 1                        | 3    | 0     | 0 | 0                        | 0    | 2     | 0 | 6     | 60            |
| 3:15 PM                         | 0                      | 0    | 0     | 0 | 0                      | 0    | 1     | 0 | 0                        | 2    | 0     | 0 | 0                        | 0    | 2     | 0 | 5     | 63            |
| 3:20 PM                         | 0                      | 0    | 0     | 0 | 0                      | 0    | 1     | 0 | 0                        | 2    | 0     | 0 | 0                        | 0    | 3     | 0 | 6     | 60            |
| 3:25 PM                         | 0                      | 0    | 0     | 0 | 0                      | 0    | 0     | 0 | 0                        | 1    | 0     | 0 | 0                        | 0    | 1     | 0 | 2     | 59            |
| 3:30 PM                         | 0                      | 0    | 0     | 0 | 0                      | 0    | 0     | 0 | 0                        | 1    | 1     | 0 | 0                        | 0    | 2     | 0 | 4     | 59            |
| 3:35 PM                         | 0                      | 0    | 1     | 0 | 0                      | 0    | 1     | 0 | 1                        | 1    | 1     | 0 | 0                        | 0    | 2     | 0 | 7     | 63            |
| 3:40 PM                         | 0                      | 0    | 0     | 0 | 1                      | 0    | 0     | 0 | 0                        | 2    | 0     | 0 | 0                        | 0    | 2     | 0 | 5     | 65            |
| 3:45 PM                         | 1                      | 0    | 0     | 0 | 0                      | 0    | 1     | 0 | 0                        | 1    | 0     | 0 | 0                        | 0    | 1     | 0 | 4     | 62            |
| 3:50 PM                         | 0                      | 0    | 0     | 0 | 0                      | 0    | 0     | 0 | 0                        | 3    | 0     | 0 | 0                        | 0    | 3     | 0 | 6     | 62            |
| 3:55 PM                         | 0                      | 0    | 0     | 0 | 0                      | 0    | 1     | 0 | 1                        | 2    | 0     | 0 | 0                        | 0    | 2     | 1 | 7     | 60            |
| 4:00 PM                         | 0                      | 0    | 0     | 0 | 0                      | 0    | 0     | 0 | 0                        | 0    | 0     | 0 | 0                        | 0    | 0     | 0 | 0     | 55            |
| 4:05 PM                         | 0                      | 0    | 0     | 0 | 0                      | 0    | 0     | 0 | 0                        | 3    | 0     | 0 | 0                        | 0    | 0     | 0 | 3     | 55            |
| 4:10 PM                         | 0                      | 0    | 0     | 0 | 0                      | 0    | 0     | 0 | 1                        | 1    | 0     | 0 | 0                        | 0    | 4     | 1 | 7     | 56            |
| 4:15 PM                         | 0                      | 0    | 0     | 0 | 0                      | 0    | 0     | 0 | 0                        | 2    | 0     | 0 | 0                        | 0    | 2     | 0 | 4     | 55            |
| 4:20 PM                         | 0                      | 0    | 0     | 0 | 0                      | 0    | 1     | 0 | 0                        | 3    | 0     | 0 | 0                        | 0    | 1     | 0 | 5     | 54            |
| 4:25 PM                         | 0                      | 0    | 0     | 0 | 0                      | 0    | 0     | 0 | 0                        | 1    | 0     | 0 | 0                        | 0    | 1     | 0 | 2     | 54            |
| 4:30 PM                         | 0                      | 0    | 0     | 0 | 0                      | 0    | 0     | 0 | 0                        | 2    | 0     | 0 | 0                        | 0    | 1     | 0 | 3     | 53            |

**Attachment B**

| 5-Min Count Period Beginning At | Vista Mar (Northbound) |      |       |   | Vista Mar (Southbound) |      |       |   | Racquet Hill (Eastbound) |      |       |   | Racquet Hill (Westbound) |      |       |   | Total | Hourly Totals |
|---------------------------------|------------------------|------|-------|---|------------------------|------|-------|---|--------------------------|------|-------|---|--------------------------|------|-------|---|-------|---------------|
|                                 | Left                   | Thru | Right | U | Left                   | Thru | Right | U | Left                     | Thru | Right | U | Left                     | Thru | Right | U |       |               |
| 4:35 PM                         | 0                      | 0    | 0     | 0 | 0                      | 0    | 0     | 0 | 0                        | 1    | 0     | 0 | 0                        | 3    | 0     | 0 | 4     | 50            |
| 4:40 PM                         | 1                      | 0    | 0     | 0 | 0                      | 0    | 1     | 0 | 0                        | 1    | 0     | 0 | 0                        | 1    | 0     | 0 | 4     | 49            |
| 4:45 PM                         | 0                      | 0    | 0     | 0 | 0                      | 0    | 0     | 0 | 0                        | 1    | 0     | 0 | 0                        | 3    | 0     | 0 | 4     | 49            |
| 4:50 PM                         | 0                      | 0    | 0     | 0 | 0                      | 0    | 1     | 0 | 0                        | 1    | 0     | 0 | 0                        | 2    | 0     | 0 | 4     | 47            |
| 4:55 PM                         | 0                      | 0    | 0     | 0 | 0                      | 0    | 1     | 0 | 0                        | 1    | 0     | 0 | 0                        | 1    | 0     | 0 | 3     | 43            |
| 5:00 PM                         | 0                      | 0    | 0     | 0 | 0                      | 0    | 0     | 0 | 1                        | 1    | 0     | 0 | 0                        | 3    | 0     | 0 | 5     | 48            |
| 5:05 PM                         | 0                      | 0    | 0     | 0 | 0                      | 0    | 0     | 0 | 1                        | 0    | 0     | 0 | 0                        | 2    | 0     | 0 | 3     | 48            |
| 5:10 PM                         | 0                      | 0    | 1     | 0 | 0                      | 1    | 0     | 0 | 2                        | 3    | 0     | 0 | 0                        | 0    | 0     | 0 | 7     | 48            |
| 5:15 PM                         | 0                      | 0    | 0     | 0 | 0                      | 0    | 0     | 0 | 0                        | 1    | 0     | 0 | 0                        | 2    | 0     | 0 | 3     | 47            |
| 5:20 PM                         | 0                      | 0    | 0     | 0 | 0                      | 0    | 0     | 0 | 2                        | 2    | 0     | 0 | 0                        | 2    | 0     | 0 | 6     | 48            |
| 5:25 PM                         | 0                      | 0    | 0     | 0 | 0                      | 0    | 2     | 0 | 1                        | 1    | 0     | 0 | 0                        | 2    | 0     | 0 | 6     | 52            |
| 5:30 PM                         | 0                      | 0    | 0     | 0 | 0                      | 0    | 0     | 0 | 0                        | 0    | 0     | 0 | 0                        | 0    | 0     | 0 | 0     | 49            |
| 5:35 PM                         | 0                      | 0    | 0     | 0 | 0                      | 0    | 0     | 0 | 0                        | 2    | 0     | 0 | 0                        | 2    | 0     | 0 | 4     | 49            |
| 5:40 PM                         | 0                      | 0    | 0     | 0 | 0                      | 0    | 0     | 0 | 1                        | 3    | 0     | 0 | 0                        | 2    | 0     | 0 | 6     | 51            |
| 5:45 PM                         | 0                      | 0    | 0     | 0 | 0                      | 0    | 1     | 0 | 1                        | 0    | 0     | 0 | 0                        | 1    | 0     | 0 | 3     | 50            |
| 5:50 PM                         | 0                      | 0    | 0     | 0 | 1                      | 0    | 0     | 0 | 0                        | 1    | 0     | 0 | 0                        | 1    | 0     | 0 | 3     | 49            |
| 5:55 PM                         | 0                      | 0    | 0     | 0 | 0                      | 0    | 0     | 0 | 0                        | 2    | 0     | 0 | 0                        | 0    | 0     | 0 | 2     | 48            |
| 6:00 PM                         | 0                      | 0    | 0     | 0 | 0                      | 0    | 0     | 0 | 1                        | 2    | 0     | 0 | 0                        | 2    | 0     | 0 | 5     | 48            |
| 6:05 PM                         | 0                      | 0    | 0     | 0 | 0                      | 0    | 0     | 0 | 0                        | 3    | 0     | 0 | 0                        | 1    | 0     | 0 | 4     | 49            |
| 6:10 PM                         | 0                      | 0    | 0     | 0 | 0                      | 0    | 0     | 0 | 0                        | 2    | 0     | 0 | 0                        | 5    | 0     | 0 | 7     | 49            |
| 6:15 PM                         | 0                      | 0    | 0     | 0 | 0                      | 0    | 0     | 0 | 0                        | 3    | 0     | 0 | 0                        | 2    | 0     | 0 | 5     | 51            |
| 6:20 PM                         | 0                      | 0    | 0     | 0 | 0                      | 0    | 0     | 0 | 1                        | 1    | 0     | 0 | 0                        | 0    | 0     | 0 | 2     | 47            |
| 6:25 PM                         | 0                      | 0    | 0     | 0 | 0                      | 0    | 0     | 0 | 0                        | 0    | 0     | 0 | 0                        | 2    | 0     | 0 | 2     | 43            |
| 6:30 PM                         | 0                      | 0    | 0     | 0 | 0                      | 0    | 0     | 0 | 0                        | 1    | 0     | 0 | 0                        | 0    | 0     | 0 | 1     | 44            |
| 6:35 PM                         | 0                      | 0    | 0     | 0 | 0                      | 0    | 0     | 0 | 0                        | 1    | 0     | 0 | 0                        | 2    | 0     | 0 | 3     | 43            |
| 6:40 PM                         | 0                      | 0    | 0     | 0 | 0                      | 0    | 0     | 0 | 0                        | 0    | 0     | 0 | 0                        | 1    | 0     | 0 | 1     | 38            |
| 6:45 PM                         | 0                      | 0    | 0     | 0 | 0                      | 0    | 0     | 0 | 0                        | 0    | 0     | 0 | 0                        | 0    | 0     | 0 | 0     | 35            |
| 6:50 PM                         | 0                      | 0    | 0     | 0 | 0                      | 0    | 1     | 0 | 1                        | 4    | 0     | 0 | 0                        | 0    | 0     | 0 | 6     | 38            |
| 6:55 PM                         | 0                      | 0    | 0     | 0 | 0                      | 0    | 1     | 0 | 0                        | 1    | 0     | 0 | 0                        | 2    | 0     | 0 | 4     | 40            |
| 7:00 PM                         | 0                      | 0    | 0     | 0 | 0                      | 0    | 0     | 0 | 0                        | 2    | 0     | 0 | 0                        | 1    | 0     | 0 | 3     | 38            |
| 7:05 PM                         | 0                      | 0    | 0     | 0 | 0                      | 0    | 0     | 0 | 0                        | 1    | 0     | 0 | 0                        | 3    | 0     | 0 | 4     | 38            |
| 7:10 PM                         | 0                      | 0    | 0     | 0 | 0                      | 0    | 0     | 0 | 1                        | 2    | 0     | 0 | 0                        | 2    | 0     | 0 | 5     | 36            |
| 7:15 PM                         | 0                      | 0    | 0     | 0 | 0                      | 0    | 0     | 0 | 0                        | 4    | 0     | 0 | 1                        | 0    | 0     | 0 | 5     | 36            |
| 7:20 PM                         | 0                      | 0    | 0     | 0 | 0                      | 0    | 0     | 0 | 0                        | 1    | 0     | 0 | 0                        | 2    | 0     | 0 | 3     | 37            |
| 7:25 PM                         | 0                      | 0    | 0     | 0 | 0                      | 0    | 0     | 0 | 0                        | 0    | 0     | 0 | 0                        | 1    | 0     | 0 | 1     | 36            |
| 7:30 PM                         | 0                      | 0    | 0     | 0 | 0                      | 0    | 0     | 0 | 0                        | 0    | 0     | 0 | 0                        | 0    | 0     | 0 | 0     | 35            |
| 7:35 PM                         | 0                      | 0    | 0     | 0 | 0                      | 0    | 0     | 0 | 0                        | 2    | 0     | 0 | 0                        | 0    | 0     | 0 | 2     | 34            |
| 7:40 PM                         | 0                      | 0    | 0     | 0 | 0                      | 0    | 0     | 0 | 0                        | 1    | 0     | 0 | 0                        | 1    | 0     | 0 | 2     | 35            |
| 7:45 PM                         | 0                      | 0    | 0     | 0 | 0                      | 0    | 0     | 0 | 1                        | 2    | 0     | 0 | 0                        | 0    | 0     | 0 | 3     | 38            |
| 7:50 PM                         | 0                      | 0    | 0     | 0 | 0                      | 0    | 0     | 0 | 0                        | 1    | 0     | 0 | 0                        | 1    | 0     | 0 | 2     | 34            |
| 7:55 PM                         | 0                      | 0    | 0     | 0 | 0                      | 0    | 0     | 0 | 0                        | 1    | 0     | 0 | 0                        | 2    | 0     | 0 | 3     | 33            |
| 8:00 PM                         | 0                      | 0    | 0     | 0 | 0                      | 0    | 0     | 0 | 0                        | 0    | 0     | 0 | 0                        | 0    | 0     | 0 | 0     | 30            |
| 8:05 PM                         | 0                      | 0    | 0     | 0 | 0                      | 0    | 0     | 0 | 0                        | 1    | 0     | 0 | 0                        | 0    | 0     | 0 | 1     | 27            |
| 8:10 PM                         | 0                      | 0    | 0     | 0 | 0                      | 0    | 0     | 0 | 0                        | 0    | 0     | 0 | 0                        | 1    | 0     | 0 | 1     | 23            |
| 8:15 PM                         | 0                      | 0    | 0     | 0 | 0                      | 0    | 0     | 0 | 0                        | 0    | 0     | 0 | 0                        | 0    | 0     | 0 | 0     | 18            |
| 8:20 PM                         | 0                      | 0    | 0     | 0 | 0                      | 0    | 0     | 0 | 0                        | 0    | 0     | 0 | 0                        | 0    | 0     | 0 | 0     | 15            |
| 8:25 PM                         | 0                      | 0    | 0     | 0 | 0                      | 0    | 0     | 0 | 0                        | 3    | 0     | 0 | 0                        | 0    | 0     | 0 | 3     | 17            |
| 8:30 PM                         | 0                      | 0    | 0     | 0 | 0                      | 0    | 0     | 0 | 0                        | 1    | 0     | 0 | 0                        | 0    | 0     | 0 | 1     | 18            |
| 8:35 PM                         | 0                      | 0    | 0     | 0 | 0                      | 0    | 0     | 0 | 0                        | 3    | 0     | 0 | 0                        | 1    | 0     | 0 | 4     | 20            |
| 8:40 PM                         | 0                      | 0    | 0     | 0 | 0                      | 0    | 0     | 0 | 0                        | 0    | 0     | 0 | 0                        | 1    | 0     | 0 | 1     | 19            |
| 8:45 PM                         | 0                      | 0    | 0     | 0 | 0                      | 0    | 0     | 0 | 0                        | 1    | 0     | 0 | 0                        | 0    | 0     | 0 | 1     | 17            |
| 8:50 PM                         | 0                      | 0    | 0     | 0 | 0                      | 0    | 1     | 0 | 0                        | 0    | 0     | 0 | 0                        | 0    | 0     | 0 | 1     | 16            |
| 8:55 PM                         | 0                      | 0    | 0     | 0 | 0                      | 0    | 0     | 0 | 0                        | 1    | 0     | 0 | 0                        | 0    | 0     | 0 | 1     | 14            |
| 9:00 PM                         | 0                      | 0    | 0     | 0 | 0                      | 0    | 0     | 0 | 1                        | 0    | 0     | 0 | 0                        | 0    | 0     | 0 | 1     | 15            |
| 9:05 PM                         | 0                      | 0    | 0     | 0 | 0                      | 0    | 0     | 0 | 0                        | 1    | 0     | 0 | 0                        | 0    | 0     | 0 | 1     | 15            |
| 9:10 PM                         | 0                      | 0    | 0     | 0 | 0                      | 0    | 0     | 0 | 0                        | 1    | 0     | 0 | 0                        | 1    | 0     | 0 | 2     | 16            |
| 9:15 PM                         | 0                      | 0    | 0     | 0 | 0                      | 0    | 0     | 0 | 0                        | 1    | 0     | 0 | 0                        | 0    | 0     | 0 | 1     | 17            |
| 9:20 PM                         | 0                      | 0    | 0     | 0 | 0                      | 0    | 0     | 0 | 0                        | 1    | 0     | 0 | 0                        | 0    | 0     | 0 | 1     | 18            |
| 9:25 PM                         | 0                      | 0    | 0     | 0 | 0                      | 0    | 0     | 0 | 1                        | 0    | 0     | 0 | 0                        | 0    | 0     | 0 | 1     | 16            |
| 9:30 PM                         | 0                      | 0    | 0     | 0 | 0                      | 0    | 0     | 0 | 1                        | 0    | 0     | 0 | 0                        | 0    | 0     | 0 | 1     | 16            |
| 9:35 PM                         | 0                      | 0    | 0     | 0 | 0                      | 0    | 0     | 0 | 0                        | 0    | 0     | 0 | 0                        | 0    | 0     | 0 | 0     | 12            |
| 9:40 PM                         | 0                      | 0    | 0     | 0 | 0                      | 0    | 0     | 0 | 0                        | 0    | 0     | 0 | 0                        | 0    | 0     | 0 | 0     | 11            |
| 9:45 PM                         | 0                      | 0    | 0     | 0 | 0                      | 0    | 0     | 0 | 0                        | 0    | 0     | 0 | 0                        | 0    | 0     | 0 | 0     | 10            |
| 9:50 PM                         | 0                      | 0    | 0     | 0 | 0                      | 0    | 0     | 0 | 0                        | 0    | 0     | 0 | 0                        | 0    | 0     | 0 | 0     | 9             |
| 9:55 PM                         | 0                      | 0    | 0     | 0 | 0                      | 0    | 0     | 0 | 0                        | 1    | 0     | 0 | 0                        | 0    | 0     | 0 | 1     | 9             |
| Peak 15-Min Flowrates           | Northbound             |      |       |   | Southbound             |      |       |   | Eastbound                |      |       |   | Westbound                |      |       |   | Total |               |
|                                 | Left                   | Thru | Right | U | Left                   | Thru | Right | U | Left                     | Thru | Right | U | Left                     | Thru | Right | U |       |               |
| All Vehicles                    | 0                      | 0    | 0     | 0 | 0                      | 0    | 8     | 0 | 16                       | 36   | 0     | 0 | 0                        | 32   | 0     | 0 | 92    |               |
| Heavy Trucks                    | 0                      | 0    | 0     | 0 | 0                      | 0    | 0     | 0 | 0                        | 0    | 0     | 0 | 0                        | 0    | 0     | 0 | 0     |               |
| Buses                           |                        |      |       |   |                        |      |       |   |                          |      |       |   |                          |      |       |   |       |               |
| Pedestrians                     |                        | 8    |       |   |                        | 0    |       |   |                          | 0    |       |   |                          | 0    |       |   | 8     |               |
| Bicycles                        | 0                      | 0    | 0     | 0 | 0                      | 0    | 0     | 0 | 0                        | 0    | 0     | 0 | 0                        | 0    | 0     | 0 | 0     |               |
| Scoters                         |                        |      |       |   |                        |      |       |   |                          |      |       |   |                          |      |       |   |       |               |
| <i>Comments:</i>                |                        |      |       |   |                        |      |       |   |                          |      |       |   |                          |      |       |   |       |               |

Type of peak hour being reported: Intersection Peak

Method for determining peak hour: Total Entering Volume

LOCATION: Dean St -- Rainbow Dr  
 CITY/STATE: North Tustin, CA

QC JOB #: 16966439  
 DATE: Thu, Apr 10 2025

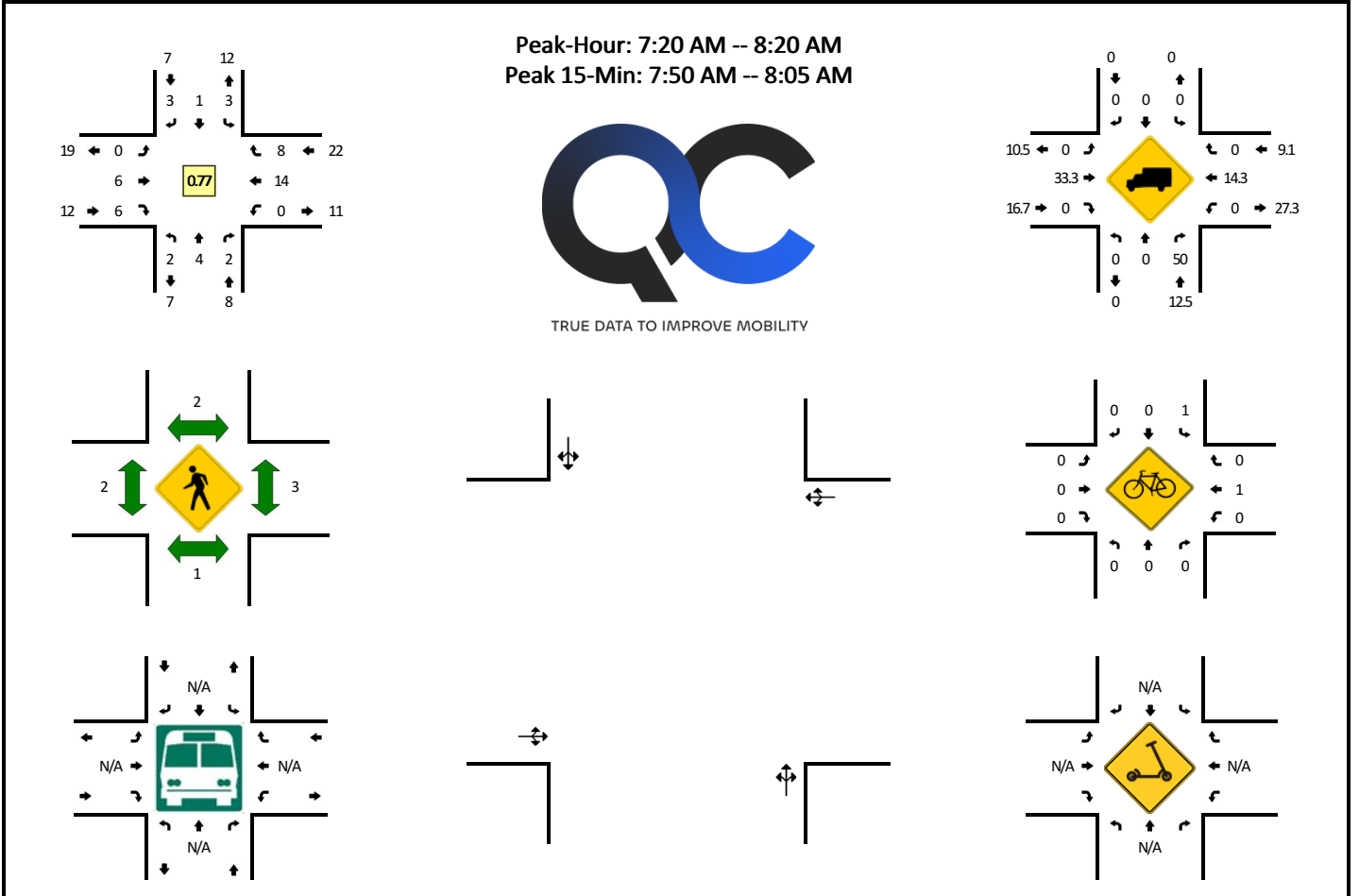

| 5-Min Count Period Beginning At | Dean St (Northbound) |      |       |   | Dean St (Southbound) |      |       |   | Rainbow Dr (Eastbound) |      |       |   | Rainbow Dr (Westbound) |      |       |   | Total | Hourly Totals |
|---------------------------------|----------------------|------|-------|---|----------------------|------|-------|---|------------------------|------|-------|---|------------------------|------|-------|---|-------|---------------|
|                                 | Left                 | Thru | Right | U | Left                 | Thru | Right | U | Left                   | Thru | Right | U | Left                   | Thru | Right | U |       |               |
| 6:00 AM                         | 0                    | 0    | 0     | 0 | 0                    | 0    | 0     | 0 | 0                      | 0    | 0     | 0 | 0                      | 0    | 0     | 0 | 0     |               |
| 6:05 AM                         | 0                    | 0    | 0     | 0 | 0                    | 0    | 0     | 0 | 0                      | 0    | 0     | 0 | 0                      | 0    | 0     | 0 | 0     |               |
| 6:10 AM                         | 0                    | 0    | 0     | 0 | 0                    | 0    | 0     | 0 | 0                      | 0    | 0     | 0 | 0                      | 0    | 0     | 0 | 0     |               |
| 6:15 AM                         | 0                    | 0    | 0     | 0 | 0                    | 0    | 0     | 0 | 0                      | 0    | 0     | 0 | 0                      | 0    | 0     | 0 | 0     |               |
| 6:20 AM                         | 0                    | 0    | 0     | 0 | 0                    | 0    | 0     | 0 | 0                      | 0    | 0     | 0 | 0                      | 1    | 0     | 0 | 1     |               |
| 6:25 AM                         | 0                    | 0    | 0     | 0 | 0                    | 0    | 0     | 0 | 0                      | 0    | 0     | 0 | 0                      | 0    | 0     | 0 | 0     |               |
| 6:30 AM                         | 0                    | 0    | 0     | 0 | 0                    | 0    | 0     | 0 | 0                      | 0    | 0     | 0 | 0                      | 1    | 0     | 0 | 1     |               |
| 6:35 AM                         | 0                    | 0    | 1     | 0 | 1                    | 0    | 0     | 0 | 0                      | 1    | 0     | 0 | 0                      | 0    | 1     | 0 | 4     |               |
| 6:40 AM                         | 0                    | 0    | 0     | 0 | 0                    | 0    | 0     | 0 | 0                      | 1    | 0     | 0 | 0                      | 0    | 0     | 0 | 1     |               |
| 6:45 AM                         | 0                    | 0    | 0     | 0 | 0                    | 0    | 0     | 0 | 0                      | 0    | 0     | 0 | 0                      | 0    | 0     | 0 | 0     |               |
| 6:50 AM                         | 0                    | 0    | 0     | 0 | 0                    | 0    | 0     | 0 | 0                      | 0    | 0     | 0 | 0                      | 1    | 0     | 0 | 1     |               |
| 6:55 AM                         | 0                    | 0    | 0     | 0 | 0                    | 0    | 0     | 0 | 0                      | 0    | 0     | 0 | 0                      | 0    | 0     | 0 | 0     |               |
| 7:00 AM                         | 0                    | 0    | 0     | 0 | 0                    | 0    | 0     | 0 | 0                      | 0    | 0     | 0 | 0                      | 0    | 0     | 0 | 8     |               |
| 7:05 AM                         | 0                    | 0    | 0     | 0 | 0                    | 0    | 0     | 0 | 0                      | 0    | 0     | 0 | 0                      | 0    | 0     | 0 | 8     |               |
| 7:10 AM                         | 0                    | 0    | 0     | 0 | 0                    | 0    | 0     | 0 | 0                      | 0    | 0     | 0 | 0                      | 0    | 0     | 0 | 8     |               |
| 7:15 AM                         | 0                    | 0    | 0     | 0 | 0                    | 0    | 0     | 0 | 0                      | 0    | 0     | 0 | 0                      | 2    | 0     | 0 | 10    |               |
| 7:20 AM                         | 0                    | 1    | 1     | 0 | 0                    | 0    | 0     | 0 | 0                      | 0    | 0     | 0 | 0                      | 4    | 1     | 0 | 16    |               |
| 7:25 AM                         | 0                    | 0    | 0     | 0 | 0                    | 0    | 1     | 0 | 0                      | 0    | 1     | 0 | 0                      | 0    | 0     | 0 | 18    |               |
| 7:30 AM                         | 0                    | 0    | 0     | 0 | 1                    | 0    | 0     | 0 | 0                      | 0    | 0     | 0 | 0                      | 2    | 0     | 0 | 20    |               |
| 7:35 AM                         | 1                    | 0    | 0     | 0 | 0                    | 0    | 0     | 0 | 0                      | 1    | 0     | 0 | 0                      | 1    | 1     | 0 | 20    |               |
| 7:40 AM                         | 0                    | 0    | 0     | 0 | 0                    | 0    | 0     | 0 | 0                      | 1    | 0     | 0 | 0                      | 1    | 0     | 0 | 21    |               |
| 7:45 AM                         | 0                    | 0    | 0     | 0 | 0                    | 0    | 0     | 0 | 0                      | 1    | 0     | 0 | 0                      | 1    | 1     | 0 | 24    |               |
| 7:50 AM                         | 0                    | 1    | 0     | 0 | 1                    | 0    | 1     | 0 | 0                      | 1    | 0     | 0 | 0                      | 0    | 3     | 0 | 30    |               |
| 7:55 AM                         | 0                    | 1    | 0     | 0 | 0                    | 0    | 0     | 0 | 0                      | 1    | 0     | 0 | 0                      | 1    | 1     | 0 | 34    |               |
| 8:00 AM                         | 1                    | 0    | 1     | 0 | 0                    | 0    | 0     | 0 | 0                      | 1    | 0     | 0 | 0                      | 2    | 0     | 0 | 39    |               |
| 8:05 AM                         | 0                    | 0    | 0     | 0 | 0                    | 0    | 0     | 0 | 0                      | 0    | 2     | 0 | 0                      | 0    | 0     | 0 | 41    |               |
| 8:10 AM                         | 0                    | 1    | 0     | 0 | 1                    | 1    | 0     | 0 | 0                      | 0    | 1     | 0 | 0                      | 0    | 1     | 0 | 46    |               |
| 8:15 AM                         | 0                    | 0    | 0     | 0 | 0                    | 0    | 1     | 0 | 0                      | 0    | 2     | 0 | 0                      | 2    | 0     | 0 | 49    |               |
| 8:20 AM                         | 0                    | 0    | 0     | 0 | 0                    | 0    | 0     | 0 | 0                      | 0    | 1     | 0 | 0                      | 0    | 0     | 0 | 43    |               |
| 8:25 AM                         | 0                    | 0    | 0     | 0 | 0                    | 0    | 1     | 0 | 0                      | 1    | 1     | 0 | 0                      | 1    | 0     | 0 | 45    |               |
| 8:30 AM                         | 2                    | 0    | 0     | 0 | 0                    | 0    | 0     | 0 | 0                      | 0    | 0     | 0 | 0                      | 0    | 0     | 0 | 44    |               |
| 8:35 AM                         | 0                    | 1    | 0     | 0 | 1                    | 0    | 0     | 0 | 0                      | 0    | 0     | 0 | 0                      | 0    | 0     | 0 | 42    |               |
| 8:40 AM                         | 0                    | 0    | 0     | 0 | 0                    | 0    | 0     | 0 | 1                      | 0    | 1     | 0 | 0                      | 0    | 0     | 0 | 42    |               |
| 8:45 AM                         | 0                    | 0    | 0     | 0 | 0                    | 0    | 0     | 0 | 0                      | 0    | 0     | 0 | 0                      | 0    | 0     | 0 | 39    |               |
| 8:50 AM                         | 0                    | 0    | 0     | 0 | 0                    | 0    | 0     | 0 | 1                      | 1    | 0     | 0 | 0                      | 1    | 0     | 0 | 35    |               |
| 8:55 AM                         | 0                    | 0    | 0     | 0 | 0                    | 0    | 0     | 0 | 0                      | 1    | 0     | 0 | 0                      | 1    | 1     | 0 | 34    |               |
| 9:00 AM                         | 0                    | 0    | 0     | 0 | 0                    | 0    | 0     | 0 | 0                      | 1    | 0     | 0 | 0                      | 0    | 1     | 0 | 31    |               |
| 9:05 AM                         | 0                    | 0    | 0     | 0 | 0                    | 0    | 0     | 0 | 0                      | 0    | 1     | 0 | 0                      | 0    | 1     | 0 | 31    |               |

Attachment B

| 5-Min Count Period Beginning At | Dean St (Northbound) |      |       |   | Dean St (Southbound) |      |       |   | Rainbow Dr (Eastbound) |      |       |   | Rainbow Dr (Westbound) |      |       |   | Total | Hourly Totals |
|---------------------------------|----------------------|------|-------|---|----------------------|------|-------|---|------------------------|------|-------|---|------------------------|------|-------|---|-------|---------------|
|                                 | Left                 | Thru | Right | U | Left                 | Thru | Right | U | Left                   | Thru | Right | U | Left                   | Thru | Right | U |       |               |
| 9:10 AM                         | 0                    | 0    | 0     | 0 | 0                    | 0    | 0     | 0 | 1                      | 0    | 0     | 0 | 0                      | 1    | 0     | 0 | 2     | 28            |
| 9:15 AM                         | 0                    | 0    | 0     | 0 | 0                    | 0    | 0     | 0 | 0                      | 0    | 0     | 0 | 0                      | 0    | 0     | 0 | 0     | 23            |
| 9:20 AM                         | 0                    | 0    | 0     | 0 | 0                    | 0    | 0     | 0 | 0                      | 0    | 0     | 0 | 0                      | 0    | 1     | 0 | 1     | 23            |
| 9:25 AM                         | 0                    | 0    | 0     | 0 | 0                    | 0    | 0     | 0 | 0                      | 1    | 0     | 0 | 0                      | 0    | 0     | 0 | 1     | 20            |
| 9:30 AM                         | 0                    | 0    | 0     | 0 | 0                    | 0    | 0     | 0 | 0                      | 0    | 0     | 0 | 0                      | 1    | 0     | 0 | 1     | 19            |
| 9:35 AM                         | 0                    | 0    | 0     | 0 | 0                    | 0    | 1     | 0 | 0                      | 0    | 0     | 0 | 0                      | 0    | 0     | 0 | 1     | 18            |
| 9:40 AM                         | 0                    | 0    | 0     | 0 | 0                    | 0    | 0     | 0 | 0                      | 0    | 0     | 0 | 0                      | 0    | 0     | 0 | 0     | 16            |
| 9:45 AM                         | 0                    | 0    | 0     | 0 | 0                    | 0    | 0     | 0 | 0                      | 1    | 1     | 0 | 0                      | 1    | 0     | 0 | 3     | 19            |
| 9:50 AM                         | 0                    | 0    | 0     | 0 | 0                    | 1    | 0     | 0 | 0                      | 0    | 0     | 0 | 0                      | 0    | 0     | 0 | 1     | 17            |
| 9:55 AM                         | 0                    | 0    | 0     | 0 | 0                    | 0    | 1     | 0 | 0                      | 0    | 0     | 0 | 0                      | 2    | 0     | 0 | 3     | 17            |
| 10:00 AM                        | 0                    | 0    | 0     | 0 | 0                    | 0    | 1     | 0 | 1                      | 1    | 0     | 0 | 1                      | 1    | 1     | 0 | 5     | 20            |
| 10:05 AM                        | 0                    | 0    | 0     | 0 | 0                    | 1    | 0     | 0 | 1                      | 0    | 0     | 0 | 0                      | 0    | 0     | 0 | 2     | 20            |
| 10:10 AM                        | 0                    | 0    | 0     | 0 | 0                    | 0    | 0     | 0 | 0                      | 1    | 0     | 0 | 0                      | 0    | 0     | 0 | 1     | 19            |
| 10:15 AM                        | 0                    | 0    | 1     | 0 | 0                    | 0    | 0     | 0 | 0                      | 1    | 0     | 0 | 0                      | 0    | 0     | 0 | 2     | 21            |
| 10:20 AM                        | 0                    | 0    | 0     | 0 | 0                    | 0    | 0     | 0 | 0                      | 0    | 0     | 0 | 0                      | 1    | 0     | 0 | 1     | 21            |
| 10:25 AM                        | 1                    | 1    | 1     | 0 | 0                    | 0    | 1     | 0 | 0                      | 0    | 1     | 0 | 0                      | 0    | 0     | 0 | 5     | 25            |
| 10:30 AM                        | 0                    | 0    | 0     | 0 | 0                    | 0    | 1     | 0 | 0                      | 0    | 0     | 0 | 1                      | 0    | 0     | 0 | 2     | 26            |
| 10:35 AM                        | 0                    | 0    | 0     | 0 | 0                    | 0    | 0     | 0 | 0                      | 1    | 1     | 0 | 0                      | 0    | 0     | 0 | 2     | 27            |
| 10:40 AM                        | 0                    | 0    | 0     | 0 | 0                    | 0    | 0     | 0 | 0                      | 1    | 0     | 0 | 0                      | 0    | 0     | 0 | 1     | 28            |
| 10:45 AM                        | 0                    | 0    | 0     | 0 | 0                    | 0    | 1     | 0 | 0                      | 0    | 0     | 0 | 0                      | 1    | 0     | 0 | 2     | 27            |
| 10:50 AM                        | 0                    | 0    | 0     | 0 | 1                    | 0    | 0     | 0 | 0                      | 0    | 1     | 0 | 0                      | 1    | 0     | 0 | 3     | 29            |
| 10:55 AM                        | 0                    | 1    | 0     | 0 | 0                    | 1    | 1     | 0 | 1                      | 0    | 0     | 0 | 0                      | 1    | 0     | 0 | 5     | 31            |
| 11:00 AM                        | 0                    | 0    | 0     | 0 | 0                    | 0    | 0     | 0 | 0                      | 0    | 1     | 0 | 0                      | 0    | 0     | 0 | 1     | 27            |
| 11:05 AM                        | 0                    | 1    | 0     | 0 | 0                    | 0    | 0     | 0 | 1                      | 1    | 1     | 0 | 0                      | 2    | 0     | 0 | 6     | 31            |
| 11:10 AM                        | 0                    | 0    | 0     | 0 | 0                    | 0    | 0     | 0 | 0                      | 1    | 0     | 0 | 0                      | 0    | 0     | 0 | 1     | 31            |
| 11:15 AM                        | 0                    | 1    | 1     | 0 | 0                    | 0    | 0     | 0 | 0                      | 0    | 0     | 0 | 0                      | 0    | 1     | 0 | 3     | 32            |
| 11:20 AM                        | 0                    | 0    | 0     | 0 | 0                    | 0    | 0     | 0 | 0                      | 0    | 0     | 0 | 0                      | 0    | 0     | 0 | 0     | 31            |
| 11:25 AM                        | 0                    | 0    | 0     | 0 | 0                    | 0    | 1     | 0 | 1                      | 0    | 1     | 0 | 0                      | 1    | 0     | 0 | 4     | 30            |
| 11:30 AM                        | 0                    | 0    | 0     | 0 | 0                    | 0    | 0     | 0 | 1                      | 0    | 0     | 0 | 0                      | 0    | 0     | 0 | 1     | 29            |
| 11:35 AM                        | 0                    | 1    | 0     | 0 | 0                    | 0    | 0     | 0 | 0                      | 0    | 0     | 0 | 0                      | 0    | 0     | 0 | 1     | 28            |
| 11:40 AM                        | 0                    | 0    | 0     | 0 | 0                    | 0    | 0     | 0 | 1                      | 0    | 1     | 0 | 1                      | 0    | 0     | 0 | 3     | 30            |
| 11:45 AM                        | 0                    | 0    | 0     | 0 | 0                    | 0    | 0     | 0 | 0                      | 4    | 0     | 0 | 0                      | 2    | 1     | 0 | 7     | 35            |
| 11:50 AM                        | 0                    | 0    | 0     | 0 | 0                    | 0    | 0     | 0 | 0                      | 1    | 0     | 0 | 0                      | 0    | 1     | 0 | 2     | 34            |
| 11:55 AM                        | 0                    | 0    | 0     | 0 | 1                    | 0    | 0     | 0 | 0                      | 1    | 0     | 0 | 0                      | 0    | 0     | 0 | 2     | 31            |
| 12:00 PM                        | 0                    | 0    | 0     | 0 | 0                    | 0    | 0     | 0 | 0                      | 0    | 0     | 0 | 0                      | 0    | 0     | 0 | 0     | 30            |
| 12:05 PM                        | 0                    | 0    | 0     | 0 | 1                    | 0    | 0     | 0 | 0                      | 0    | 0     | 0 | 0                      | 1    | 0     | 0 | 2     | 26            |
| 12:10 PM                        | 1                    | 0    | 0     | 0 | 0                    | 0    | 0     | 0 | 1                      | 1    | 0     | 0 | 1                      | 0    | 1     | 0 | 5     | 30            |
| 12:15 PM                        | 0                    | 0    | 0     | 0 | 0                    | 0    | 1     | 0 | 0                      | 1    | 0     | 0 | 0                      | 1    | 0     | 0 | 3     | 30            |
| 12:20 PM                        | 1                    | 0    | 0     | 0 | 0                    | 0    | 0     | 0 | 0                      | 0    | 0     | 0 | 0                      | 0    | 1     | 0 | 2     | 32            |
| 12:25 PM                        | 0                    | 0    | 0     | 0 | 0                    | 0    | 0     | 0 | 0                      | 1    | 0     | 0 | 0                      | 1    | 0     | 0 | 2     | 30            |
| 12:30 PM                        | 0                    | 0    | 0     | 0 | 0                    | 0    | 0     | 0 | 0                      | 1    | 0     | 0 | 0                      | 0    | 0     | 0 | 1     | 30            |
| 12:35 PM                        | 0                    | 0    | 0     | 0 | 0                    | 0    | 0     | 0 | 0                      | 1    | 0     | 0 | 0                      | 0    | 1     | 0 | 2     | 31            |
| 12:40 PM                        | 0                    | 0    | 0     | 0 | 0                    | 0    | 0     | 0 | 0                      | 0    | 0     | 0 | 0                      | 2    | 1     | 0 | 3     | 31            |
| 12:45 PM                        | 0                    | 0    | 1     | 0 | 0                    | 0    | 0     | 0 | 0                      | 1    | 0     | 0 | 0                      | 0    | 0     | 0 | 2     | 26            |
| 12:50 PM                        | 0                    | 0    | 0     | 0 | 0                    | 1    | 0     | 0 | 0                      | 0    | 0     | 0 | 0                      | 1    | 0     | 0 | 2     | 26            |
| 12:55 PM                        | 0                    | 0    | 0     | 0 | 0                    | 0    | 1     | 0 | 0                      | 0    | 0     | 0 | 0                      | 0    | 0     | 0 | 1     | 25            |
| 1:00 PM                         | 2                    | 0    | 0     | 0 | 0                    | 0    | 1     | 0 | 0                      | 1    | 1     | 0 | 0                      | 0    | 0     | 0 | 5     | 30            |
| 1:05 PM                         | 0                    | 0    | 0     | 0 | 0                    | 0    | 0     | 0 | 0                      | 1    | 0     | 0 | 0                      | 0    | 0     | 0 | 1     | 29            |
| 1:10 PM                         | 0                    | 0    | 0     | 0 | 0                    | 0    | 0     | 0 | 0                      | 0    | 0     | 0 | 0                      | 1    | 0     | 0 | 1     | 25            |
| 1:15 PM                         | 0                    | 0    | 0     | 0 | 0                    | 0    | 0     | 0 | 0                      | 1    | 0     | 0 | 0                      | 0    | 1     | 0 | 2     | 24            |
| 1:20 PM                         | 0                    | 0    | 1     | 0 | 0                    | 0    | 0     | 0 | 0                      | 0    | 1     | 0 | 1                      | 0    | 1     | 0 | 4     | 26            |
| 1:25 PM                         | 0                    | 1    | 0     | 0 | 0                    | 0    | 0     | 0 | 0                      | 1    | 0     | 0 | 0                      | 0    | 0     | 0 | 2     | 26            |
| 1:30 PM                         | 0                    | 1    | 1     | 0 | 0                    | 0    | 0     | 0 | 0                      | 1    | 0     | 0 | 1                      | 1    | 0     | 0 | 5     | 30            |
| 1:35 PM                         | 0                    | 0    | 0     | 0 | 0                    | 0    | 0     | 0 | 0                      | 2    | 0     | 0 | 0                      | 1    | 0     | 0 | 3     | 31            |
| 1:40 PM                         | 0                    | 0    | 0     | 0 | 0                    | 0    | 0     | 0 | 0                      | 0    | 0     | 0 | 0                      | 0    | 0     | 0 | 0     | 28            |
| 1:45 PM                         | 0                    | 0    | 0     | 0 | 0                    | 0    | 0     | 0 | 0                      | 1    | 1     | 0 | 0                      | 1    | 0     | 0 | 3     | 29            |
| 1:50 PM                         | 1                    | 0    | 0     | 0 | 0                    | 0    | 0     | 0 | 0                      | 1    | 1     | 0 | 0                      | 0    | 0     | 0 | 3     | 30            |
| 1:55 PM                         | 0                    | 0    | 0     | 0 | 0                    | 0    | 0     | 0 | 0                      | 1    | 0     | 0 | 0                      | 1    | 1     | 0 | 3     | 32            |
| 2:00 PM                         | 2                    | 0    | 0     | 0 | 0                    | 0    | 0     | 0 | 0                      | 0    | 0     | 0 | 0                      | 0    | 0     | 0 | 2     | 29            |
| 2:05 PM                         | 0                    | 0    | 0     | 0 | 0                    | 0    | 0     | 0 | 0                      | 1    | 0     | 0 | 0                      | 1    | 0     | 0 | 2     | 30            |
| 2:10 PM                         | 0                    | 0    | 0     | 0 | 0                    | 0    | 1     | 0 | 0                      | 0    | 1     | 0 | 0                      | 0    | 0     | 0 | 2     | 31            |
| 2:15 PM                         | 0                    | 0    | 0     | 0 | 0                    | 0    | 0     | 0 | 0                      | 0    | 1     | 0 | 0                      | 2    | 1     | 0 | 4     | 33            |
| 2:20 PM                         | 1                    | 1    | 1     | 0 | 1                    | 0    | 0     | 0 | 0                      | 1    | 1     | 0 | 0                      | 2    | 0     | 0 | 8     | 37            |
| 2:25 PM                         | 0                    | 0    | 0     | 0 | 0                    | 0    | 0     | 0 | 0                      | 1    | 0     | 0 | 0                      | 0    | 0     | 0 | 1     | 36            |
| 2:30 PM                         | 0                    | 1    | 0     | 0 | 0                    | 1    | 0     | 0 | 0                      | 0    | 2     | 0 | 0                      | 0    | 0     | 0 | 4     | 35            |
| 2:35 PM                         | 0                    | 0    | 1     | 0 | 0                    | 0    | 0     | 0 | 0                      | 0    | 0     | 0 | 0                      | 3    | 0     | 0 | 4     | 36            |
| 2:40 PM                         | 0                    | 0    | 0     | 0 | 1                    | 0    | 0     | 0 | 0                      | 1    | 0     | 0 | 0                      | 0    | 1     | 0 | 3     | 39            |
| 2:45 PM                         | 0                    | 0    | 0     | 0 | 1                    | 0    | 0     | 0 | 0                      | 0    | 0     | 0 | 0                      | 2    | 0     | 0 | 3     | 39            |
| 2:50 PM                         | 0                    | 0    | 0     | 0 | 0                    | 0    | 0     | 0 | 0                      | 0    | 0     | 0 | 0                      | 1    | 0     | 0 | 1     | 37            |
| 2:55 PM                         | 0                    | 0    | 0     | 0 | 0                    | 0    | 0     | 0 | 0                      | 2    | 0     | 0 | 1                      | 2    | 0     | 0 | 5     | 39            |
| 3:00 PM                         | 0                    | 0    | 0     | 0 | 0                    | 0    | 0     | 0 | 1                      | 3    | 1     | 0 | 0                      | 0    | 0     | 0 | 5     | 42            |
| 3:05 PM                         | 0                    | 0    | 0     | 0 | 0                    | 0    | 1     | 0 | 0                      | 2    | 0     | 0 | 0                      | 0    | 0     | 0 | 3     | 43            |
| 3:10 PM                         | 0                    | 0    | 0     | 0 | 0                    | 1    | 1     | 0 | 0                      | 1    | 1     | 0 | 0                      | 2    | 1     | 0 | 7     | 48            |
| 3:15 PM                         | 0                    | 0    | 0     | 0 | 0                    | 0    | 2     | 0 | 1                      | 0    | 1     | 0 | 0                      | 0    | 1     | 0 | 5     | 49            |
| 3:20 PM                         | 0                    | 0    | 0     | 0 | 0                    | 0    | 0     | 0 | 0                      | 0    | 0     | 0 | 0                      | 0    | 1     | 0 | 1     | 42            |
| 3:25 PM                         | 0                    | 0    | 0     | 0 | 0                    | 0    | 0     | 0 | 0                      | 2    | 0     | 0 | 0                      | 0    | 0     | 0 | 2     | 43            |
| 3:30 PM                         | 0                    | 0    | 0     | 0 | 0                    | 0    | 0     | 0 | 0                      | 2    | 0     | 0 | 0                      | 0    | 0     | 0 | 2     | 41            |
| 3:35 PM                         | 0                    | 0    | 0     | 0 | 0                    | 0    | 0     | 0 | 0                      | 2    | 0     | 0 | 0                      | 0    | 0     | 0 | 2     | 39            |
| 3:40 PM                         | 0                    | 0    | 0     | 0 | 0                    | 0    | 0     | 0 | 0                      | 0    | 1     | 0 | 0                      | 0    | 0     | 0 | 1     | 37            |
| 3:45 PM                         | 0                    | 0    | 0     | 0 | 0                    | 0    | 0     | 0 | 0                      | 3    | 0     | 0 | 0                      | 1    | 0     | 0 | 4     | 38            |
| 3:50 PM                         | 0                    | 0    | 0     | 0 | 0                    | 0    | 0     | 0 | 0                      | 1    | 2     | 0 | 0                      | 0    | 2     | 0 | 5     | 42            |
| 3:55 PM                         | 0                    | 0    | 0     | 0 | 0                    | 0    | 0     | 0 | 0                      | 3    | 2     | 0 | 0                      | 2    | 1     | 0 | 8     | 45            |
| 4:00 PM                         | 1                    | 0    | 0     | 0 | 0                    | 0    | 0     | 0 | 0                      | 2    | 0     | 0 | 0                      | 1    | 0     | 0 | 4     | 44            |
| 4:05 PM                         | 1                    | 0    | 0     | 0 | 0                    | 0    | 0     | 0 | 0                      | 0    | 1     | 0 | 0                      | 1    | 0     | 0 | 3     | 44            |
| 4:10 PM                         | 0                    | 1    | 0     | 0 | 0                    | 0    | 0     | 0 | 0                      | 2    | 0     | 0 | 0                      | 2    | 1     | 0 | 6     | 43            |
| 4:15 PM                         | 0                    | 0    | 0     | 0 | 0                    | 0    | 1     | 0 | 0                      | 1    | 0     | 0 | 0                      | 0    | 0     | 0 | 2     | 40            |
| 4:20 PM                         | 0                    | 0    | 0     | 0 | 0                    | 0    | 0     | 0 | 0                      | 1    | 0     | 0 | 1                      | 1    | 0     | 0 | 3     | 42            |
| 4:25 PM                         | 0                    | 0    | 0     | 0 | 0                    | 0    | 0     | 0 | 0                      | 1    | 0     | 0 | 0                      | 0    | 2     | 0 | 3     | 43            |
| 4:30 PM                         | 1                    | 0    | 0     | 0 | 1                    | 0    | 0     | 0 | 0                      | 0    | 0     | 0 | 1                      | 1    | 0     | 0 | 4     | 45            |

**Attachment B**

| 5-Min Count Period Beginning At | Dean St (Northbound) |      |       |   | Dean St (Southbound) |      |       |   | Rainbow Dr (Eastbound) |      |       |   | Rainbow Dr (Westbound) |      |       |   | Total | Hourly Totals |
|---------------------------------|----------------------|------|-------|---|----------------------|------|-------|---|------------------------|------|-------|---|------------------------|------|-------|---|-------|---------------|
|                                 | Left                 | Thru | Right | U | Left                 | Thru | Right | U | Left                   | Thru | Right | U | Left                   | Thru | Right | U |       |               |
| 4:35 PM                         | 0                    | 0    | 1     | 0 | 0                    | 0    | 0     | 0 | 1                      | 0    | 0     | 0 | 0                      | 0    | 0     | 0 | 2     | 45            |
| 4:40 PM                         | 1                    | 0    | 1     | 0 | 0                    | 0    | 0     | 0 | 0                      | 0    | 1     | 0 | 0                      | 0    | 1     | 0 | 4     | 48            |
| 4:45 PM                         | 1                    | 0    | 0     | 0 | 0                    | 0    | 0     | 0 | 0                      | 1    | 0     | 0 | 0                      | 2    | 0     | 0 | 4     | 48            |
| 4:50 PM                         | 0                    | 0    | 0     | 0 | 0                    | 0    | 0     | 0 | 0                      | 0    | 1     | 0 | 0                      | 0    | 0     | 0 | 1     | 44            |
| 4:55 PM                         | 1                    | 0    | 0     | 0 | 0                    | 0    | 0     | 0 | 1                      | 1    | 1     | 0 | 0                      | 0    | 2     | 0 | 6     | 42            |
| 5:00 PM                         | 0                    | 0    | 0     | 0 | 1                    | 0    | 0     | 0 | 0                      | 0    | 0     | 0 | 0                      | 1    | 1     | 0 | 3     | 41            |
| 5:05 PM                         | 1                    | 0    | 0     | 0 | 0                    | 0    | 1     | 0 | 1                      | 2    | 1     | 0 | 1                      | 0    | 0     | 0 | 7     | 45            |
| 5:10 PM                         | 0                    | 0    | 0     | 0 | 0                    | 0    | 0     | 0 | 0                      | 1    | 0     | 0 | 0                      | 1    | 2     | 0 | 4     | 43            |
| 5:15 PM                         | 0                    | 0    | 0     | 0 | 0                    | 0    | 0     | 0 | 0                      | 0    | 0     | 0 | 0                      | 1    | 0     | 0 | 1     | 42            |
| 5:20 PM                         | 0                    | 0    | 0     | 0 | 0                    | 0    | 0     | 0 | 0                      | 0    | 0     | 0 | 0                      | 0    | 1     | 0 | 1     | 40            |
| 5:25 PM                         | 0                    | 0    | 0     | 0 | 0                    | 0    | 0     | 0 | 0                      | 1    | 1     | 0 | 0                      | 0    | 1     | 0 | 3     | 40            |
| 5:30 PM                         | 0                    | 0    | 0     | 0 | 1                    | 0    | 0     | 0 | 0                      | 2    | 0     | 0 | 0                      | 1    | 0     | 0 | 4     | 40            |
| 5:35 PM                         | 1                    | 0    | 1     | 0 | 1                    | 0    | 0     | 0 | 1                      | 0    | 0     | 0 | 1                      | 2    | 1     | 0 | 8     | 46            |
| 5:40 PM                         | 0                    | 0    | 0     | 0 | 0                    | 0    | 0     | 0 | 0                      | 2    | 0     | 0 | 0                      | 0    | 0     | 0 | 2     | 44            |
| 5:45 PM                         | 0                    | 0    | 0     | 0 | 0                    | 0    | 0     | 0 | 0                      | 0    | 0     | 0 | 0                      | 1    | 1     | 0 | 2     | 42            |
| 5:50 PM                         | 0                    | 0    | 0     | 0 | 1                    | 0    | 0     | 0 | 0                      | 1    | 0     | 0 | 0                      | 2    | 1     | 0 | 5     | 46            |
| 5:55 PM                         | 0                    | 0    | 0     | 0 | 0                    | 0    | 0     | 0 | 0                      | 0    | 0     | 0 | 0                      | 2    | 0     | 0 | 2     | 42            |
| 6:00 PM                         | 0                    | 0    | 0     | 0 | 1                    | 0    | 0     | 0 | 0                      | 0    | 0     | 0 | 0                      | 0    | 0     | 0 | 1     | 40            |
| 6:05 PM                         | 0                    | 0    | 0     | 0 | 0                    | 0    | 0     | 0 | 0                      | 1    | 3     | 0 | 0                      | 2    | 0     | 0 | 6     | 39            |
| 6:10 PM                         | 0                    | 0    | 0     | 0 | 0                    | 0    | 0     | 0 | 0                      | 1    | 1     | 0 | 0                      | 0    | 2     | 0 | 4     | 39            |
| 6:15 PM                         | 1                    | 0    | 0     | 0 | 0                    | 0    | 0     | 0 | 0                      | 1    | 1     | 0 | 0                      | 2    | 0     | 0 | 5     | 43            |
| 6:20 PM                         | 0                    | 0    | 0     | 0 | 0                    | 0    | 0     | 0 | 0                      | 0    | 0     | 0 | 0                      | 2    | 0     | 0 | 2     | 44            |
| 6:25 PM                         | 1                    | 0    | 1     | 0 | 0                    | 0    | 0     | 0 | 0                      | 0    | 2     | 0 | 0                      | 0    | 0     | 0 | 4     | 45            |
| 6:30 PM                         | 0                    | 0    | 0     | 0 | 0                    | 0    | 0     | 0 | 0                      | 3    | 2     | 0 | 0                      | 2    | 1     | 0 | 8     | 49            |
| 6:35 PM                         | 1                    | 0    | 0     | 0 | 0                    | 0    | 0     | 0 | 0                      | 1    | 0     | 0 | 0                      | 0    | 0     | 0 | 2     | 43            |
| 6:40 PM                         | 0                    | 0    | 0     | 0 | 0                    | 0    | 0     | 0 | 0                      | 2    | 1     | 0 | 0                      | 0    | 0     | 0 | 3     | 44            |
| 6:45 PM                         | 1                    | 0    | 0     | 0 | 0                    | 0    | 0     | 0 | 0                      | 1    | 0     | 0 | 0                      | 1    | 1     | 0 | 4     | 46            |
| 6:50 PM                         | 0                    | 0    | 0     | 0 | 0                    | 0    | 1     | 0 | 0                      | 0    | 1     | 0 | 0                      | 0    | 1     | 0 | 3     | 44            |
| 6:55 PM                         | 0                    | 0    | 0     | 0 | 0                    | 0    | 0     | 0 | 0                      | 0    | 1     | 0 | 0                      | 0    | 0     | 0 | 1     | 43            |
| 7:00 PM                         | 1                    | 0    | 0     | 0 | 0                    | 0    | 0     | 0 | 0                      | 0    | 0     | 0 | 0                      | 0    | 0     | 0 | 1     | 43            |
| 7:05 PM                         | 0                    | 0    | 0     | 0 | 0                    | 0    | 0     | 0 | 0                      | 0    | 0     | 0 | 0                      | 1    | 0     | 0 | 1     | 38            |
| 7:10 PM                         | 0                    | 0    | 0     | 0 | 0                    | 0    | 0     | 0 | 0                      | 1    | 0     | 0 | 0                      | 0    | 0     | 0 | 1     | 35            |
| 7:15 PM                         | 2                    | 0    | 0     | 0 | 0                    | 0    | 0     | 0 | 0                      | 1    | 0     | 0 | 0                      | 0    | 0     | 0 | 3     | 33            |
| 7:20 PM                         | 0                    | 0    | 0     | 0 | 0                    | 1    | 0     | 0 | 0                      | 1    | 0     | 0 | 0                      | 0    | 1     | 0 | 3     | 34            |
| 7:25 PM                         | 0                    | 0    | 0     | 0 | 0                    | 0    | 0     | 0 | 0                      | 1    | 0     | 0 | 0                      | 0    | 0     | 0 | 1     | 31            |
| 7:30 PM                         | 0                    | 0    | 0     | 0 | 0                    | 0    | 0     | 0 | 0                      | 0    | 0     | 0 | 1                      | 1    | 0     | 0 | 2     | 25            |
| 7:35 PM                         | 1                    | 0    | 0     | 0 | 0                    | 0    | 0     | 0 | 0                      | 1    | 1     | 0 | 0                      | 0    | 0     | 0 | 3     | 26            |
| 7:40 PM                         | 0                    | 0    | 0     | 0 | 0                    | 0    | 0     | 0 | 0                      | 0    | 0     | 0 | 0                      | 0    | 0     | 0 | 0     | 23            |
| 7:45 PM                         | 0                    | 0    | 0     | 0 | 0                    | 0    | 0     | 0 | 0                      | 0    | 1     | 0 | 0                      | 0    | 0     | 0 | 1     | 20            |
| 7:50 PM                         | 0                    | 0    | 0     | 0 | 0                    | 0    | 0     | 0 | 0                      | 0    | 0     | 0 | 0                      | 0    | 0     | 0 | 0     | 17            |
| 7:55 PM                         | 0                    | 0    | 0     | 0 | 0                    | 0    | 0     | 0 | 0                      | 0    | 0     | 0 | 0                      | 0    | 0     | 0 | 0     | 16            |
| 8:00 PM                         | 1                    | 0    | 0     | 0 | 1                    | 0    | 0     | 0 | 0                      | 1    | 0     | 0 | 0                      | 0    | 0     | 0 | 3     | 18            |
| 8:05 PM                         | 0                    | 0    | 0     | 0 | 0                    | 0    | 0     | 0 | 0                      | 0    | 0     | 0 | 0                      | 0    | 0     | 0 | 0     | 17            |
| 8:10 PM                         | 0                    | 0    | 0     | 0 | 0                    | 0    | 0     | 0 | 0                      | 1    | 0     | 0 | 0                      | 0    | 0     | 0 | 1     | 17            |
| 8:15 PM                         | 0                    | 0    | 1     | 0 | 0                    | 1    | 0     | 0 | 0                      | 1    | 1     | 0 | 0                      | 0    | 1     | 0 | 5     | 19            |
| 8:20 PM                         | 0                    | 0    | 0     | 0 | 0                    | 0    | 0     | 0 | 0                      | 1    | 0     | 0 | 0                      | 0    | 0     | 0 | 1     | 17            |
| 8:25 PM                         | 0                    | 0    | 0     | 0 | 0                    | 0    | 0     | 0 | 0                      | 0    | 0     | 0 | 0                      | 1    | 0     | 0 | 1     | 17            |
| 8:30 PM                         | 0                    | 0    | 0     | 0 | 0                    | 0    | 0     | 0 | 0                      | 0    | 0     | 0 | 0                      | 0    | 1     | 0 | 1     | 16            |
| 8:35 PM                         | 0                    | 0    | 0     | 0 | 0                    | 0    | 0     | 0 | 0                      | 0    | 0     | 0 | 0                      | 0    | 0     | 0 | 0     | 13            |
| 8:40 PM                         | 0                    | 0    | 0     | 0 | 0                    | 1    | 0     | 0 | 1                      | 0    | 0     | 0 | 1                      | 0    | 0     | 0 | 3     | 16            |
| 8:45 PM                         | 0                    | 1    | 0     | 0 | 0                    | 0    | 0     | 0 | 0                      | 1    | 0     | 0 | 0                      | 0    | 1     | 0 | 3     | 18            |
| 8:50 PM                         | 0                    | 0    | 0     | 0 | 0                    | 0    | 0     | 0 | 0                      | 1    | 0     | 0 | 0                      | 0    | 0     | 0 | 1     | 19            |
| 8:55 PM                         | 0                    | 0    | 0     | 0 | 0                    | 0    | 0     | 0 | 0                      | 0    | 1     | 0 | 0                      | 0    | 0     | 0 | 1     | 20            |
| 9:00 PM                         | 0                    | 0    | 0     | 0 | 0                    | 0    | 0     | 0 | 0                      | 0    | 0     | 0 | 0                      | 0    | 0     | 0 | 0     | 17            |
| 9:05 PM                         | 0                    | 0    | 0     | 0 | 1                    | 0    | 0     | 0 | 0                      | 0    | 1     | 0 | 0                      | 1    | 0     | 0 | 3     | 20            |
| 9:10 PM                         | 0                    | 0    | 0     | 0 | 0                    | 0    | 0     | 0 | 0                      | 0    | 1     | 0 | 0                      | 0    | 0     | 0 | 1     | 20            |
| 9:15 PM                         | 0                    | 0    | 0     | 0 | 0                    | 0    | 0     | 0 | 0                      | 1    | 0     | 0 | 0                      | 0    | 0     | 0 | 1     | 16            |
| 9:20 PM                         | 0                    | 0    | 0     | 0 | 0                    | 0    | 0     | 0 | 0                      | 0    | 0     | 0 | 0                      | 0    | 0     | 0 | 0     | 15            |
| 9:25 PM                         | 0                    | 0    | 0     | 0 | 0                    | 0    | 0     | 0 | 0                      | 0    | 0     | 0 | 0                      | 0    | 0     | 0 | 0     | 14            |
| 9:30 PM                         | 0                    | 0    | 0     | 0 | 0                    | 0    | 0     | 0 | 0                      | 1    | 0     | 0 | 0                      | 0    | 1     | 0 | 2     | 15            |
| 9:35 PM                         | 0                    | 0    | 0     | 0 | 0                    | 0    | 0     | 0 | 0                      | 0    | 0     | 0 | 0                      | 0    | 0     | 0 | 0     | 15            |
| 9:40 PM                         | 0                    | 0    | 0     | 0 | 0                    | 0    | 0     | 0 | 0                      | 1    | 0     | 0 | 0                      | 0    | 0     | 0 | 1     | 13            |
| 9:45 PM                         | 0                    | 0    | 0     | 0 | 0                    | 0    | 0     | 0 | 0                      | 0    | 0     | 0 | 0                      | 0    | 0     | 0 | 0     | 10            |
| 9:50 PM                         | 0                    | 0    | 0     | 0 | 0                    | 0    | 0     | 0 | 0                      | 0    | 0     | 0 | 0                      | 0    | 0     | 0 | 0     | 9             |
| 9:55 PM                         | 0                    | 0    | 0     | 0 | 0                    | 0    | 0     | 0 | 0                      | 0    | 0     | 0 | 0                      | 0    | 0     | 0 | 0     | 8             |
| Peak 15-Min Flowrates           | Northbound           |      |       |   | Southbound           |      |       |   | Eastbound              |      |       |   | Westbound              |      |       |   | Total |               |
|                                 | Left                 | Thru | Right | U | Left                 | Thru | Right | U | Left                   | Thru | Right | U | Left                   | Thru | Right | U |       |               |
| All Vehicles                    | 4                    | 8    | 4     | 0 | 4                    | 0    | 4     | 0 | 0                      | 12   | 0     | 0 | 0                      | 12   | 16    | 0 | 64    |               |
| Heavy Trucks                    | 0                    | 0    | 4     |   | 0                    | 0    | 0     |   | 0                      | 8    | 0     |   | 0                      | 8    | 0     |   | 20    |               |
| Buses                           |                      | 0    |       |   |                      | 0    |       |   |                        | 8    |       |   |                        | 0    |       |   | 8     |               |
| Pedestrians                     |                      | 0    |       |   |                      | 0    |       |   |                        | 0    |       |   |                        | 0    |       |   | 0     |               |
| Bicycles                        | 0                    | 0    | 0     |   | 0                    | 0    | 0     |   | 0                      | 0    | 0     |   | 0                      | 0    | 0     |   | 0     |               |
| Scoters                         |                      |      |       |   |                      |      |       |   |                        |      |       |   |                        |      |       |   |       |               |
| <i>Comments:</i>                |                      |      |       |   |                      |      |       |   |                        |      |       |   |                        |      |       |   |       |               |

LOCATION: Bubbling Well Rd -- Rainbow Dr  
 CITY/STATE: North Tustin, CA

QC JOB #: 16966440  
 DATE: Thu, Apr 10 2025

Peak-Hour: 7:35 AM -- 8:35 AM  
 Peak 15-Min: 8:00 AM -- 8:15 AM

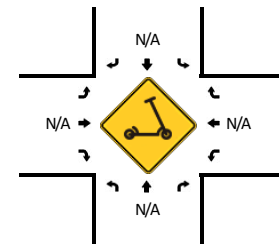
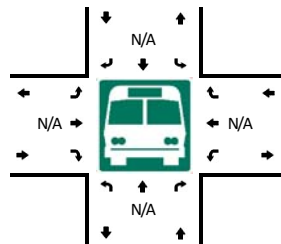
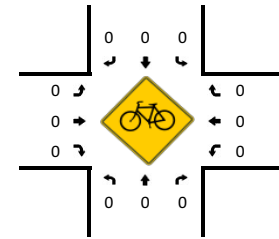
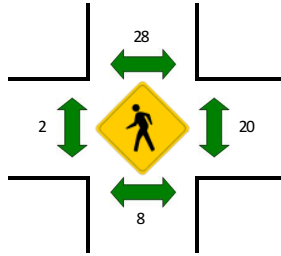
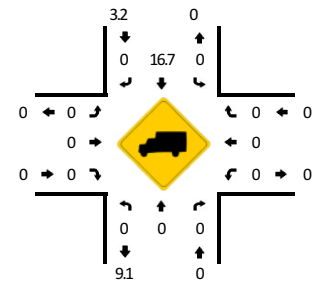
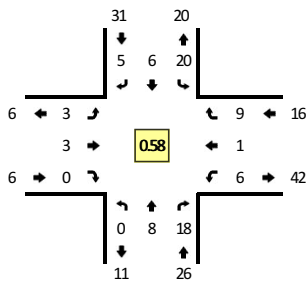

| 5-Min Count Period Beginning At | Bubbling Well Rd (Northbound) |      |       |   | Bubbling Well Rd (Southbound) |      |       |   | Rainbow Dr (Eastbound) |      |       |   | Rainbow Dr (Westbound) |      |       |   | Total | Hourly Totals |
|---------------------------------|-------------------------------|------|-------|---|-------------------------------|------|-------|---|------------------------|------|-------|---|------------------------|------|-------|---|-------|---------------|
|                                 | Left                          | Thru | Right | U | Left                          | Thru | Right | U | Left                   | Thru | Right | U | Left                   | Thru | Right | U |       |               |
| 6:00 AM                         | 0                             | 0    | 0     | 0 | 0                             | 0    | 0     | 0 | 0                      | 0    | 0     | 0 | 0                      | 0    | 0     | 0 | 0     | 0             |
| 6:05 AM                         | 0                             | 0    | 0     | 0 | 0                             | 0    | 0     | 0 | 0                      | 0    | 0     | 0 | 0                      | 0    | 0     | 0 | 0     | 0             |
| 6:10 AM                         | 0                             | 0    | 0     | 0 | 1                             | 0    | 0     | 0 | 0                      | 0    | 0     | 0 | 0                      | 0    | 0     | 0 | 0     | 1             |
| 6:15 AM                         | 0                             | 0    | 0     | 0 | 0                             | 0    | 0     | 0 | 0                      | 0    | 0     | 0 | 0                      | 1    | 0     | 0 | 0     | 1             |
| 6:20 AM                         | 0                             | 1    | 0     | 0 | 0                             | 0    | 0     | 0 | 0                      | 0    | 0     | 0 | 0                      | 0    | 0     | 0 | 0     | 1             |
| 6:25 AM                         | 0                             | 0    | 0     | 0 | 0                             | 0    | 0     | 0 | 0                      | 0    | 0     | 0 | 0                      | 0    | 0     | 0 | 0     | 0             |
| 6:30 AM                         | 0                             | 0    | 0     | 0 | 0                             | 0    | 0     | 0 | 0                      | 0    | 0     | 0 | 0                      | 0    | 0     | 0 | 0     | 0             |
| 6:35 AM                         | 0                             | 0    | 0     | 0 | 0                             | 0    | 0     | 0 | 0                      | 0    | 0     | 0 | 0                      | 0    | 0     | 0 | 0     | 0             |
| 6:40 AM                         | 0                             | 0    | 0     | 0 | 0                             | 0    | 0     | 0 | 0                      | 0    | 0     | 0 | 0                      | 0    | 0     | 0 | 0     | 0             |
| 6:45 AM                         | 0                             | 0    | 0     | 0 | 1                             | 0    | 0     | 0 | 0                      | 0    | 0     | 0 | 0                      | 0    | 0     | 0 | 0     | 1             |
| 6:50 AM                         | 0                             | 0    | 0     | 0 | 0                             | 0    | 0     | 0 | 0                      | 0    | 0     | 0 | 0                      | 0    | 0     | 0 | 0     | 0             |
| 6:55 AM                         | 0                             | 0    | 1     | 0 | 0                             | 0    | 0     | 0 | 0                      | 0    | 0     | 0 | 1                      | 0    | 0     | 0 | 0     | 2             |
| 7:00 AM                         | 0                             | 0    | 1     | 0 | 1                             | 0    | 0     | 0 | 0                      | 0    | 0     | 0 | 1                      | 0    | 0     | 0 | 0     | 3             |
| 7:05 AM                         | 0                             | 0    | 0     | 0 | 1                             | 0    | 0     | 0 | 0                      | 0    | 0     | 0 | 0                      | 0    | 0     | 0 | 0     | 1             |
| 7:10 AM                         | 0                             | 0    | 0     | 0 | 0                             | 0    | 0     | 0 | 0                      | 0    | 0     | 0 | 0                      | 0    | 0     | 0 | 0     | 0             |
| 7:15 AM                         | 0                             | 1    | 0     | 0 | 0                             | 1    | 0     | 0 | 0                      | 0    | 0     | 0 | 1                      | 0    | 0     | 0 | 0     | 3             |
| 7:20 AM                         | 0                             | 0    | 1     | 0 | 1                             | 0    | 0     | 0 | 0                      | 0    | 0     | 0 | 0                      | 0    | 1     | 0 | 0     | 3             |
| 7:25 AM                         | 0                             | 0    | 1     | 0 | 1                             | 0    | 0     | 0 | 0                      | 0    | 0     | 0 | 1                      | 0    | 0     | 0 | 0     | 3             |
| 7:30 AM                         | 0                             | 1    | 1     | 0 | 1                             | 0    | 0     | 0 | 0                      | 0    | 0     | 0 | 0                      | 0    | 0     | 0 | 0     | 3             |
| 7:35 AM                         | 0                             | 1    | 2     | 0 | 1                             | 0    | 0     | 0 | 0                      | 0    | 0     | 0 | 0                      | 0    | 0     | 0 | 0     | 4             |
| 7:40 AM                         | 0                             | 1    | 0     | 0 | 0                             | 0    | 0     | 0 | 0                      | 0    | 0     | 0 | 0                      | 0    | 1     | 0 | 0     | 2             |
| 7:45 AM                         | 0                             | 0    | 0     | 0 | 1                             | 0    | 0     | 0 | 0                      | 0    | 0     | 0 | 0                      | 0    | 0     | 0 | 0     | 1             |
| 7:50 AM                         | 0                             | 0    | 0     | 0 | 0                             | 1    | 0     | 0 | 0                      | 0    | 0     | 0 | 0                      | 0    | 2     | 1 | 0     | 4             |
| 7:55 AM                         | 0                             | 1    | 1     | 0 | 2                             | 0    | 0     | 0 | 0                      | 0    | 0     | 0 | 0                      | 0    | 0     | 0 | 0     | 4             |
| 8:00 AM                         | 0                             | 1    | 1     | 0 | 4                             | 2    | 2     | 0 | 1                      | 1    | 0     | 0 | 2                      | 0    | 0     | 0 | 0     | 14            |
| 8:05 AM                         | 0                             | 0    | 1     | 0 | 6                             | 1    | 3     | 0 | 0                      | 0    | 0     | 0 | 0                      | 0    | 0     | 0 | 0     | 11            |
| 8:10 AM                         | 0                             | 0    | 1     | 0 | 3                             | 1    | 0     | 0 | 0                      | 0    | 0     | 0 | 2                      | 0    | 2     | 0 | 0     | 9             |
| 8:15 AM                         | 0                             | 2    | 3     | 0 | 1                             | 0    | 0     | 0 | 1                      | 0    | 0     | 0 | 0                      | 0    | 1     | 0 | 0     | 8             |
| 8:20 AM                         | 0                             | 2    | 4     | 0 | 1                             | 0    | 0     | 0 | 1                      | 0    | 0     | 0 | 0                      | 0    | 2     | 0 | 0     | 10            |
| 8:25 AM                         | 0                             | 0    | 2     | 0 | 1                             | 0    | 0     | 0 | 0                      | 2    | 0     | 0 | 1                      | 1    | 1     | 0 | 0     | 8             |
| 8:30 AM                         | 0                             | 0    | 3     | 0 | 0                             | 1    | 0     | 0 | 0                      | 0    | 0     | 0 | 0                      | 0    | 0     | 0 | 0     | 4             |
| 8:35 AM                         | 0                             | 1    | 0     | 0 | 1                             | 0    | 0     | 0 | 0                      | 0    | 0     | 0 | 0                      | 0    | 0     | 0 | 0     | 2             |
| 8:40 AM                         | 0                             | 0    | 0     | 0 | 1                             | 0    | 0     | 0 | 0                      | 0    | 0     | 0 | 0                      | 0    | 0     | 0 | 0     | 1             |
| 8:45 AM                         | 0                             | 1    | 0     | 0 | 0                             | 0    | 0     | 0 | 0                      | 0    | 0     | 0 | 0                      | 0    | 1     | 0 | 0     | 2             |
| 8:50 AM                         | 0                             | 0    | 1     | 0 | 1                             | 0    | 0     | 0 | 0                      | 0    | 0     | 0 | 0                      | 0    | 2     | 0 | 0     | 4             |
| 8:55 AM                         | 0                             | 0    | 0     | 0 | 0                             | 0    | 0     | 0 | 0                      | 0    | 0     | 0 | 1                      | 0    | 2     | 0 | 0     | 3             |
| 9:00 AM                         | 0                             | 0    | 0     | 0 | 0                             | 0    | 0     | 0 | 0                      | 0    | 0     | 0 | 1                      | 0    | 0     | 0 | 0     | 1             |
| 9:05 AM                         | 0                             | 0    | 0     | 0 | 1                             | 1    | 0     | 0 | 0                      | 0    | 0     | 0 | 2                      | 0    | 2     | 0 | 0     | 6             |

**Attachment B**

| 5-Min Count<br>Period<br>Beginning At | Bubbling Well Rd<br>(Northbound) |      |       |   | Bubbling Well Rd<br>(Southbound) |      |       |   | Rainbow Dr<br>(Eastbound) |      |       |   | Rainbow Dr<br>(Westbound) |      |       |   | Total | Hourly<br>Totals |
|---------------------------------------|----------------------------------|------|-------|---|----------------------------------|------|-------|---|---------------------------|------|-------|---|---------------------------|------|-------|---|-------|------------------|
|                                       | Left                             | Thru | Right | U | Left                             | Thru | Right | U | Left                      | Thru | Right | U | Left                      | Thru | Right | U |       |                  |
| 9:10 AM                               | 0                                | 0    | 1     | 0 | 1                                | 1    | 0     | 0 | 0                         | 0    | 0     | 0 | 1                         | 0    | 1     | 0 | 5     | 54               |
| 9:15 AM                               | 0                                | 0    | 0     | 0 | 1                                | 1    | 0     | 0 | 0                         | 0    | 0     | 0 | 0                         | 0    | 0     | 0 | 2     | 48               |
| 9:20 AM                               | 0                                | 0    | 1     | 0 | 0                                | 1    | 0     | 0 | 0                         | 0    | 0     | 0 | 1                         | 0    | 0     | 0 | 3     | 41               |
| 9:25 AM                               | 0                                | 1    | 1     | 0 | 1                                | 0    | 0     | 0 | 0                         | 0    | 0     | 0 | 0                         | 0    | 1     | 0 | 4     | 37               |
| 9:30 AM                               | 0                                | 0    | 0     | 0 | 0                                | 0    | 0     | 0 | 0                         | 0    | 0     | 0 | 0                         | 0    | 0     | 0 | 0     | 33               |
| 9:35 AM                               | 0                                | 0    | 0     | 0 | 1                                | 0    | 0     | 0 | 0                         | 0    | 0     | 0 | 1                         | 0    | 0     | 0 | 2     | 33               |
| 9:40 AM                               | 0                                | 0    | 0     | 0 | 0                                | 0    | 0     | 0 | 0                         | 0    | 0     | 0 | 0                         | 0    | 0     | 0 | 0     | 32               |
| 9:45 AM                               | 0                                | 0    | 0     | 0 | 1                                | 0    | 0     | 0 | 0                         | 0    | 0     | 0 | 1                         | 0    | 0     | 0 | 2     | 32               |
| 9:50 AM                               | 0                                | 0    | 0     | 0 | 1                                | 1    | 0     | 0 | 0                         | 1    | 0     | 0 | 0                         | 0    | 0     | 0 | 3     | 31               |
| 9:55 AM                               | 0                                | 0    | 2     | 0 | 1                                | 0    | 0     | 0 | 0                         | 0    | 0     | 0 | 0                         | 0    | 0     | 0 | 3     | 31               |
| 10:00 AM                              | 0                                | 0    | 1     | 0 | 1                                | 0    | 0     | 0 | 0                         | 0    | 0     | 0 | 0                         | 0    | 0     | 0 | 2     | 32               |
| 10:05 AM                              | 0                                | 0    | 1     | 0 | 1                                | 1    | 0     | 0 | 0                         | 0    | 0     | 0 | 1                         | 1    | 0     | 0 | 5     | 31               |
| 10:10 AM                              | 0                                | 0    | 2     | 0 | 0                                | 0    | 0     | 0 | 0                         | 0    | 0     | 0 | 1                         | 0    | 1     | 0 | 4     | 30               |
| 10:15 AM                              | 0                                | 0    | 1     | 0 | 0                                | 0    | 0     | 0 | 0                         | 0    | 0     | 0 | 1                         | 0    | 1     | 0 | 3     | 31               |
| 10:20 AM                              | 0                                | 0    | 1     | 0 | 0                                | 2    | 0     | 0 | 0                         | 0    | 0     | 0 | 0                         | 0    | 0     | 0 | 3     | 31               |
| 10:25 AM                              | 0                                | 0    | 2     | 0 | 0                                | 0    | 0     | 0 | 0                         | 0    | 0     | 0 | 2                         | 0    | 1     | 0 | 5     | 32               |
| 10:30 AM                              | 0                                | 0    | 1     | 0 | 2                                | 0    | 0     | 0 | 0                         | 0    | 0     | 0 | 0                         | 0    | 0     | 0 | 3     | 35               |
| 10:35 AM                              | 0                                | 1    | 1     | 0 | 2                                | 1    | 1     | 0 | 1                         | 0    | 0     | 0 | 0                         | 0    | 1     | 0 | 8     | 41               |
| 10:40 AM                              | 0                                | 0    | 1     | 0 | 0                                | 0    | 0     | 0 | 0                         | 0    | 0     | 0 | 1                         | 0    | 0     | 0 | 2     | 43               |
| 10:45 AM                              | 0                                | 1    | 1     | 0 | 0                                | 0    | 0     | 0 | 0                         | 0    | 0     | 0 | 0                         | 0    | 0     | 0 | 2     | 43               |
| 10:50 AM                              | 0                                | 0    | 1     | 0 | 0                                | 0    | 0     | 0 | 0                         | 1    | 0     | 0 | 1                         | 0    | 1     | 0 | 4     | 44               |
| 10:55 AM                              | 0                                | 0    | 0     | 0 | 0                                | 0    | 0     | 0 | 0                         | 0    | 0     | 0 | 1                         | 0    | 0     | 0 | 1     | 42               |
| 11:00 AM                              | 0                                | 0    | 0     | 0 | 0                                | 0    | 0     | 0 | 0                         | 0    | 0     | 0 | 2                         | 0    | 1     | 0 | 3     | 43               |
| 11:05 AM                              | 0                                | 1    | 1     | 0 | 0                                | 0    | 0     | 0 | 0                         | 0    | 0     | 0 | 0                         | 0    | 1     | 0 | 3     | 41               |
| 11:10 AM                              | 0                                | 0    | 0     | 0 | 0                                | 0    | 0     | 0 | 0                         | 0    | 0     | 0 | 0                         | 0    | 0     | 0 | 0     | 37               |
| 11:15 AM                              | 0                                | 0    | 0     | 0 | 0                                | 0    | 0     | 0 | 0                         | 0    | 0     | 0 | 0                         | 0    | 0     | 0 | 0     | 34               |
| 11:20 AM                              | 0                                | 0    | 0     | 0 | 1                                | 0    | 0     | 0 | 0                         | 0    | 0     | 0 | 0                         | 0    | 0     | 0 | 1     | 32               |
| 11:25 AM                              | 0                                | 0    | 0     | 0 | 2                                | 0    | 0     | 0 | 0                         | 0    | 0     | 0 | 0                         | 1    | 0     | 0 | 3     | 30               |
| 11:30 AM                              | 0                                | 0    | 0     | 0 | 0                                | 0    | 0     | 0 | 0                         | 0    | 0     | 0 | 1                         | 1    | 0     | 0 | 2     | 29               |
| 11:35 AM                              | 0                                | 0    | 1     | 0 | 0                                | 0    | 0     | 0 | 0                         | 0    | 0     | 0 | 1                         | 0    | 0     | 0 | 2     | 23               |
| 11:40 AM                              | 0                                | 0    | 2     | 0 | 0                                | 0    | 0     | 0 | 0                         | 0    | 0     | 0 | 0                         | 0    | 2     | 0 | 4     | 25               |
| 11:45 AM                              | 0                                | 0    | 0     | 0 | 0                                | 0    | 0     | 0 | 0                         | 0    | 0     | 0 | 0                         | 0    | 0     | 0 | 0     | 23               |
| 11:50 AM                              | 0                                | 1    | 1     | 0 | 2                                | 0    | 0     | 0 | 0                         | 0    | 0     | 0 | 3                         | 0    | 1     | 0 | 8     | 27               |
| 11:55 AM                              | 0                                | 0    | 0     | 0 | 2                                | 0    | 0     | 0 | 0                         | 0    | 0     | 0 | 1                         | 0    | 0     | 0 | 3     | 29               |
| 12:00 PM                              | 0                                | 1    | 0     | 0 | 1                                | 0    | 0     | 0 | 0                         | 0    | 0     | 0 | 0                         | 0    | 0     | 0 | 2     | 28               |
| 12:05 PM                              | 0                                | 0    | 1     | 0 | 4                                | 0    | 0     | 0 | 0                         | 0    | 0     | 0 | 2                         | 0    | 1     | 0 | 8     | 33               |
| 12:10 PM                              | 0                                | 0    | 2     | 0 | 0                                | 0    | 0     | 0 | 0                         | 0    | 0     | 0 | 0                         | 0    | 0     | 0 | 2     | 35               |
| 12:15 PM                              | 0                                | 0    | 2     | 0 | 0                                | 2    | 0     | 0 | 0                         | 0    | 0     | 0 | 0                         | 0    | 0     | 0 | 4     | 39               |
| 12:20 PM                              | 0                                | 0    | 0     | 0 | 0                                | 1    | 0     | 0 | 0                         | 0    | 0     | 0 | 2                         | 0    | 0     | 0 | 3     | 41               |
| 12:25 PM                              | 0                                | 0    | 0     | 0 | 0                                | 0    | 0     | 0 | 0                         | 0    | 0     | 0 | 0                         | 0    | 0     | 0 | 0     | 38               |
| 12:30 PM                              | 0                                | 0    | 0     | 0 | 0                                | 0    | 0     | 0 | 0                         | 0    | 0     | 0 | 0                         | 0    | 0     | 0 | 0     | 36               |
| 12:35 PM                              | 0                                | 0    | 1     | 0 | 0                                | 1    | 0     | 0 | 0                         | 0    | 0     | 0 | 1                         | 0    | 0     | 0 | 3     | 37               |
| 12:40 PM                              | 0                                | 0    | 1     | 0 | 1                                | 1    | 0     | 0 | 1                         | 0    | 0     | 0 | 0                         | 0    | 2     | 0 | 6     | 39               |
| 12:45 PM                              | 0                                | 0    | 2     | 0 | 1                                | 0    | 0     | 0 | 0                         | 0    | 0     | 0 | 0                         | 0    | 0     | 0 | 3     | 42               |
| 12:50 PM                              | 0                                | 0    | 0     | 0 | 0                                | 0    | 0     | 0 | 0                         | 0    | 0     | 0 | 0                         | 0    | 0     | 0 | 0     | 34               |
| 12:55 PM                              | 0                                | 0    | 1     | 0 | 2                                | 0    | 0     | 0 | 0                         | 0    | 0     | 0 | 0                         | 0    | 1     | 0 | 4     | 35               |
| 1:00 PM                               | 0                                | 0    | 2     | 0 | 1                                | 0    | 0     | 0 | 0                         | 0    | 0     | 0 | 2                         | 0    | 1     | 0 | 6     | 39               |
| 1:05 PM                               | 0                                | 0    | 0     | 0 | 0                                | 0    | 0     | 0 | 0                         | 0    | 0     | 0 | 0                         | 0    | 0     | 0 | 0     | 31               |
| 1:10 PM                               | 0                                | 0    | 0     | 0 | 0                                | 0    | 0     | 0 | 0                         | 0    | 0     | 0 | 0                         | 0    | 0     | 0 | 0     | 29               |
| 1:15 PM                               | 0                                | 0    | 0     | 0 | 1                                | 0    | 0     | 0 | 0                         | 0    | 0     | 0 | 0                         | 0    | 0     | 0 | 1     | 26               |
| 1:20 PM                               | 0                                | 0    | 1     | 0 | 1                                | 0    | 0     | 0 | 0                         | 0    | 0     | 0 | 0                         | 0    | 1     | 0 | 3     | 26               |
| 1:25 PM                               | 0                                | 0    | 0     | 0 | 0                                | 0    | 0     | 0 | 0                         | 0    | 0     | 0 | 0                         | 0    | 0     | 0 | 0     | 26               |
| 1:30 PM                               | 0                                | 0    | 1     | 0 | 0                                | 0    | 0     | 0 | 0                         | 0    | 0     | 0 | 2                         | 0    | 0     | 0 | 3     | 29               |
| 1:35 PM                               | 0                                | 0    | 1     | 0 | 2                                | 0    | 0     | 0 | 0                         | 0    | 0     | 0 | 1                         | 0    | 0     | 0 | 4     | 30               |
| 1:40 PM                               | 0                                | 0    | 1     | 0 | 1                                | 0    | 0     | 0 | 0                         | 1    | 0     | 0 | 0                         | 0    | 0     | 0 | 3     | 27               |
| 1:45 PM                               | 0                                | 0    | 1     | 0 | 2                                | 0    | 0     | 0 | 0                         | 0    | 0     | 0 | 0                         | 0    | 1     | 0 | 4     | 28               |
| 1:50 PM                               | 0                                | 0    | 0     | 0 | 1                                | 0    | 0     | 0 | 0                         | 1    | 0     | 0 | 1                         | 1    | 4     | 0 | 8     | 36               |
| 1:55 PM                               | 0                                | 0    | 0     | 0 | 0                                | 1    | 0     | 0 | 0                         | 0    | 0     | 0 | 0                         | 0    | 3     | 0 | 4     | 36               |
| 2:00 PM                               | 0                                | 0    | 2     | 0 | 2                                | 0    | 0     | 0 | 0                         | 0    | 0     | 0 | 0                         | 0    | 1     | 0 | 5     | 35               |
| 2:05 PM                               | 0                                | 0    | 0     | 0 | 3                                | 0    | 0     | 0 | 0                         | 0    | 0     | 0 | 0                         | 0    | 0     | 0 | 3     | 38               |
| 2:10 PM                               | 0                                | 0    | 0     | 0 | 0                                | 0    | 0     | 0 | 0                         | 0    | 0     | 0 | 0                         | 0    | 1     | 0 | 1     | 39               |
| 2:15 PM                               | 0                                | 0    | 0     | 0 | 2                                | 0    | 0     | 0 | 0                         | 0    | 0     | 0 | 1                         | 0    | 0     | 0 | 3     | 41               |
| 2:20 PM                               | 0                                | 0    | 1     | 0 | 1                                | 0    | 0     | 0 | 0                         | 0    | 0     | 0 | 1                         | 0    | 0     | 0 | 3     | 41               |
| 2:25 PM                               | 0                                | 1    | 0     | 0 | 2                                | 1    | 0     | 0 | 0                         | 0    | 0     | 0 | 1                         | 0    | 1     | 0 | 6     | 47               |
| 2:30 PM                               | 0                                | 0    | 1     | 0 | 2                                | 1    | 1     | 0 | 0                         | 0    | 0     | 0 | 1                         | 0    | 3     | 0 | 9     | 53               |
| 2:35 PM                               | 0                                | 0    | 0     | 0 | 1                                | 1    | 2     | 0 | 0                         | 0    | 0     | 0 | 0                         | 1    | 1     | 0 | 6     | 55               |
| 2:40 PM                               | 0                                | 1    | 0     | 0 | 0                                | 3    | 0     | 0 | 0                         | 0    | 0     | 0 | 2                         | 0    | 0     | 0 | 6     | 58               |
| 2:45 PM                               | 0                                | 2    | 1     | 0 | 3                                | 1    | 0     | 0 | 0                         | 0    | 0     | 0 | 3                         | 0    | 1     | 0 | 11    | 65               |
| 2:50 PM                               | 0                                | 2    | 3     | 0 | 0                                | 0    | 1     | 0 | 3                         | 0    | 0     | 0 | 0                         | 0    | 5     | 0 | 14    | 71               |
| 2:55 PM                               | 0                                | 0    | 3     | 0 | 0                                | 0    | 0     | 0 | 1                         | 1    | 0     | 0 | 1                         | 0    | 1     | 0 | 7     | 74               |
| 3:00 PM                               | 0                                | 0    | 0     | 0 | 1                                | 2    | 0     | 0 | 0                         | 0    | 0     | 0 | 0                         | 1    | 0     | 0 | 4     | 73               |
| 3:05 PM                               | 0                                | 2    | 0     | 0 | 1                                | 0    | 0     | 0 | 0                         | 0    | 0     | 0 | 0                         | 0    | 1     | 0 | 4     | 74               |
| 3:10 PM                               | 0                                | 0    | 0     | 0 | 1                                | 0    | 0     | 0 | 0                         | 1    | 0     | 0 | 1                         | 0    | 0     | 0 | 3     | 76               |
| 3:15 PM                               | 0                                | 0    | 0     | 0 | 0                                | 0    | 0     | 0 | 0                         | 0    | 0     | 0 | 0                         | 0    | 1     | 0 | 1     | 74               |
| 3:20 PM                               | 0                                | 0    | 0     | 0 | 2                                | 0    | 0     | 0 | 0                         | 0    | 0     | 0 | 0                         | 0    | 0     | 0 | 2     | 73               |
| 3:25 PM                               | 0                                | 0    | 0     | 0 | 1                                | 0    | 0     | 0 | 0                         | 0    | 0     | 0 | 2                         | 0    | 1     | 0 | 4     | 71               |
| 3:30 PM                               | 0                                | 0    | 0     | 0 | 0                                | 0    | 0     | 0 | 0                         | 0    | 0     | 0 | 1                         | 0    | 0     | 0 | 1     | 63               |
| 3:35 PM                               | 0                                | 1    | 0     | 0 | 0                                | 0    | 0     | 0 | 0                         | 0    | 0     | 0 | 2                         | 1    | 0     | 0 | 4     | 61               |
| 3:40 PM                               | 0                                | 1    | 1     | 0 | 1                                | 0    | 0     | 0 | 0                         | 0    | 0     | 0 | 1                         | 0    | 1     | 0 | 5     | 60               |
| 3:45 PM                               | 0                                | 1    | 0     | 0 | 2                                | 0    | 0     | 0 | 0                         | 0    | 0     | 0 | 0                         | 0    | 0     | 0 | 3     | 52               |
| 3:50 PM                               | 0                                | 0    | 0     | 0 | 0                                | 0    | 0     | 0 | 0                         | 0    | 0     | 0 | 0                         | 0    | 1     | 0 | 1     | 39               |
| 3:55 PM                               | 0                                | 0    | 0     | 0 | 2                                | 1    | 0     | 0 | 0                         | 0    | 0     | 0 | 0                         | 0    | 0     | 0 | 3     | 35               |
| 4:00 PM                               | 0                                | 0    | 1     | 0 | 0                                | 0    | 0     | 0 | 0                         | 0    | 0     | 0 | 0                         | 0    | 2     | 0 | 3     | 34               |
| 4:05 PM                               | 0                                | 0    | 0     | 0 | 1                                | 0    | 0     | 0 | 0                         | 0    | 0     | 0 | 0                         | 0    | 0     | 0 | 1     | 31               |
| 4:10 PM                               | 0                                | 0    | 0     | 0 | 1                                | 0    | 0     | 0 | 0                         | 0    | 0     | 0 | 0                         | 0    | 2     | 0 | 3     | 31               |
| 4:15 PM                               | 0                                | 0    | 1     | 0 | 0                                | 0    | 1     | 0 | 1                         | 0    | 0     | 0 | 1                         | 0    | 0     | 0 | 4     | 34               |
| 4:20 PM                               | 0                                | 1    | 2     | 0 | 0                                | 0    | 0     | 0 | 0                         | 0    | 0     | 0 | 1                         | 0    | 0     | 0 | 4     | 36               |
| 4:25 PM                               | 0                                | 0    | 1     | 0 | 0                                | 0    | 0     | 0 | 0                         | 0    | 0     | 0 | 1                         | 0    | 0     | 0 | 2     | 34               |
| 4:30 PM                               | 0                                | 0    | 0     | 0 | 0                                | 0    | 0     | 0 | 0                         | 0    | 0     | 0 | 1                         | 0    | 0     | 0 | 1     | 34               |

**Attachment B**

| 5-Min Count Period Beginning At | Bubbling Well Rd (Northbound) |      |       |   | Bubbling Well Rd (Southbound) |      |       |   | Rainbow Dr (Eastbound) |      |       |   | Rainbow Dr (Westbound) |      |       |   | Total | Hourly Totals |
|---------------------------------|-------------------------------|------|-------|---|-------------------------------|------|-------|---|------------------------|------|-------|---|------------------------|------|-------|---|-------|---------------|
|                                 | Left                          | Thru | Right | U | Left                          | Thru | Right | U | Left                   | Thru | Right | U | Left                   | Thru | Right | U |       |               |
| 4:35 PM                         | 0                             | 0    | 0     | 0 | 0                             | 0    | 0     | 0 | 0                      | 0    | 0     | 0 | 0                      | 1    | 3     | 0 | 4     | 34            |
| 4:40 PM                         | 0                             | 0    | 0     | 0 | 1                             | 0    | 0     | 0 | 0                      | 0    | 1     | 0 | 0                      | 0    | 1     | 0 | 3     | 32            |
| 4:45 PM                         | 0                             | 0    | 0     | 0 | 1                             | 0    | 0     | 0 | 0                      | 0    | 0     | 0 | 0                      | 0    | 1     | 0 | 4     | 33            |
| 4:50 PM                         | 0                             | 0    | 0     | 0 | 0                             | 0    | 0     | 0 | 0                      | 0    | 0     | 0 | 0                      | 0    | 0     | 0 | 0     | 32            |
| 4:55 PM                         | 0                             | 0    | 1     | 0 | 1                             | 0    | 0     | 0 | 0                      | 0    | 0     | 0 | 1                      | 0    | 1     | 0 | 4     | 33            |
| 5:00 PM                         | 0                             | 0    | 1     | 0 | 0                             | 0    | 0     | 0 | 0                      | 0    | 0     | 0 | 0                      | 0    | 1     | 0 | 2     | 32            |
| 5:05 PM                         | 0                             | 0    | 3     | 0 | 1                             | 1    | 0     | 0 | 0                      | 0    | 0     | 0 | 0                      | 0    | 0     | 0 | 5     | 36            |
| 5:10 PM                         | 0                             | 1    | 2     | 0 | 1                             | 0    | 0     | 0 | 0                      | 0    | 0     | 0 | 1                      | 0    | 0     | 0 | 5     | 38            |
| 5:15 PM                         | 0                             | 0    | 1     | 0 | 0                             | 0    | 0     | 0 | 0                      | 0    | 0     | 0 | 0                      | 0    | 1     | 0 | 2     | 36            |
| 5:20 PM                         | 0                             | 0    | 0     | 0 | 0                             | 0    | 0     | 0 | 0                      | 0    | 0     | 0 | 2                      | 0    | 0     | 0 | 2     | 34            |
| 5:25 PM                         | 0                             | 0    | 0     | 0 | 0                             | 0    | 0     | 0 | 0                      | 0    | 0     | 0 | 2                      | 0    | 1     | 0 | 3     | 35            |
| 5:30 PM                         | 0                             | 0    | 0     | 0 | 0                             | 1    | 0     | 0 | 0                      | 0    | 0     | 0 | 2                      | 0    | 0     | 0 | 3     | 37            |
| 5:35 PM                         | 0                             | 0    | 0     | 0 | 1                             | 0    | 0     | 0 | 0                      | 0    | 0     | 0 | 1                      | 0    | 1     | 0 | 3     | 36            |
| 5:40 PM                         | 0                             | 0    | 2     | 0 | 1                             | 0    | 0     | 0 | 0                      | 0    | 0     | 0 | 1                      | 0    | 1     | 0 | 5     | 38            |
| 5:45 PM                         | 0                             | 0    | 0     | 0 | 0                             | 0    | 0     | 0 | 0                      | 0    | 1     | 0 | 0                      | 0    | 0     | 0 | 2     | 36            |
| 5:50 PM                         | 0                             | 0    | 0     | 0 | 0                             | 0    | 0     | 0 | 0                      | 0    | 0     | 0 | 0                      | 0    | 0     | 0 | 0     | 36            |
| 5:55 PM                         | 0                             | 0    | 1     | 0 | 0                             | 0    | 0     | 0 | 0                      | 0    | 0     | 0 | 2                      | 0    | 0     | 0 | 3     | 35            |
| 6:00 PM                         | 0                             | 0    | 0     | 0 | 0                             | 0    | 0     | 0 | 0                      | 0    | 0     | 0 | 1                      | 0    | 1     | 0 | 2     | 35            |
| 6:05 PM                         | 0                             | 1    | 0     | 0 | 0                             | 1    | 0     | 0 | 0                      | 0    | 0     | 0 | 0                      | 0    | 1     | 0 | 3     | 33            |
| 6:10 PM                         | 0                             | 0    | 0     | 0 | 0                             | 0    | 0     | 0 | 0                      | 0    | 0     | 0 | 4                      | 0    | 0     | 0 | 4     | 32            |
| 6:15 PM                         | 0                             | 0    | 0     | 0 | 0                             | 0    | 0     | 0 | 0                      | 0    | 0     | 0 | 0                      | 0    | 1     | 0 | 1     | 31            |
| 6:20 PM                         | 0                             | 1    | 0     | 0 | 0                             | 0    | 0     | 0 | 0                      | 0    | 0     | 0 | 1                      | 0    | 0     | 0 | 2     | 31            |
| 6:25 PM                         | 0                             | 1    | 0     | 0 | 0                             | 0    | 0     | 0 | 0                      | 0    | 0     | 0 | 0                      | 0    | 1     | 0 | 2     | 30            |
| 6:30 PM                         | 0                             | 0    | 0     | 0 | 0                             | 1    | 0     | 0 | 0                      | 0    | 0     | 0 | 0                      | 0    | 1     | 0 | 2     | 29            |
| 6:35 PM                         | 0                             | 0    | 0     | 0 | 2                             | 0    | 0     | 0 | 0                      | 0    | 0     | 0 | 2                      | 0    | 2     | 0 | 6     | 32            |
| 6:40 PM                         | 0                             | 0    | 1     | 0 | 0                             | 1    | 0     | 0 | 0                      | 0    | 0     | 0 | 1                      | 0    | 0     | 0 | 3     | 30            |
| 6:45 PM                         | 0                             | 0    | 1     | 0 | 0                             | 1    | 0     | 0 | 0                      | 0    | 0     | 0 | 1                      | 0    | 0     | 0 | 3     | 31            |
| 6:50 PM                         | 0                             | 0    | 1     | 0 | 0                             | 0    | 0     | 0 | 0                      | 0    | 0     | 0 | 1                      | 0    | 1     | 0 | 3     | 34            |
| 6:55 PM                         | 0                             | 0    | 2     | 0 | 0                             | 0    | 0     | 0 | 0                      | 0    | 0     | 0 | 1                      | 0    | 1     | 0 | 4     | 35            |
| 7:00 PM                         | 0                             | 0    | 2     | 0 | 0                             | 0    | 0     | 0 | 0                      | 0    | 0     | 0 | 0                      | 0    | 0     | 0 | 2     | 35            |
| 7:05 PM                         | 0                             | 0    | 0     | 0 | 0                             | 0    | 0     | 0 | 0                      | 0    | 0     | 0 | 1                      | 0    | 2     | 0 | 3     | 35            |
| 7:10 PM                         | 0                             | 0    | 1     | 0 | 0                             | 0    | 0     | 0 | 0                      | 0    | 0     | 0 | 0                      | 0    | 1     | 0 | 2     | 33            |
| 7:15 PM                         | 0                             | 0    | 1     | 0 | 1                             | 2    | 0     | 0 | 0                      | 0    | 0     | 0 | 1                      | 0    | 2     | 0 | 7     | 39            |
| 7:20 PM                         | 0                             | 0    | 1     | 0 | 2                             | 0    | 0     | 0 | 0                      | 0    | 0     | 0 | 0                      | 1    | 0     | 0 | 4     | 41            |
| 7:25 PM                         | 0                             | 0    | 0     | 0 | 0                             | 1    | 0     | 0 | 0                      | 0    | 0     | 0 | 1                      | 0    | 1     | 0 | 3     | 42            |
| 7:30 PM                         | 0                             | 0    | 0     | 0 | 0                             | 0    | 0     | 0 | 0                      | 0    | 0     | 0 | 1                      | 0    | 0     | 0 | 1     | 41            |
| 7:35 PM                         | 0                             | 1    | 0     | 0 | 0                             | 0    | 0     | 0 | 0                      | 0    | 0     | 0 | 0                      | 0    | 0     | 0 | 1     | 36            |
| 7:40 PM                         | 0                             | 0    | 0     | 0 | 0                             | 0    | 0     | 0 | 0                      | 0    | 0     | 0 | 0                      | 0    | 2     | 0 | 2     | 35            |
| 7:45 PM                         | 0                             | 0    | 0     | 0 | 1                             | 0    | 0     | 0 | 0                      | 0    | 0     | 0 | 2                      | 0    | 1     | 0 | 4     | 36            |
| 7:50 PM                         | 0                             | 0    | 0     | 0 | 0                             | 0    | 0     | 0 | 0                      | 0    | 0     | 0 | 0                      | 0    | 0     | 0 | 0     | 33            |
| 7:55 PM                         | 0                             | 0    | 0     | 0 | 0                             | 0    | 0     | 0 | 0                      | 0    | 0     | 0 | 0                      | 0    | 0     | 0 | 0     | 29            |
| 8:00 PM                         | 0                             | 0    | 0     | 0 | 0                             | 0    | 0     | 0 | 0                      | 0    | 0     | 0 | 0                      | 0    | 1     | 0 | 1     | 28            |
| 8:05 PM                         | 0                             | 0    | 1     | 0 | 0                             | 0    | 0     | 0 | 0                      | 0    | 0     | 0 | 0                      | 0    | 0     | 0 | 1     | 26            |
| 8:10 PM                         | 0                             | 0    | 0     | 0 | 1                             | 0    | 0     | 0 | 0                      | 0    | 0     | 0 | 0                      | 0    | 0     | 0 | 1     | 25            |
| 8:15 PM                         | 0                             | 0    | 0     | 0 | 0                             | 0    | 0     | 0 | 0                      | 0    | 0     | 0 | 0                      | 0    | 0     | 0 | 0     | 18            |
| 8:20 PM                         | 0                             | 0    | 0     | 0 | 0                             | 0    | 0     | 0 | 0                      | 0    | 0     | 0 | 0                      | 0    | 0     | 0 | 0     | 14            |
| 8:25 PM                         | 0                             | 1    | 0     | 0 | 0                             | 0    | 0     | 0 | 0                      | 0    | 0     | 0 | 0                      | 0    | 1     | 0 | 2     | 13            |
| 8:30 PM                         | 0                             | 0    | 1     | 0 | 0                             | 0    | 0     | 0 | 0                      | 0    | 0     | 0 | 0                      | 0    | 0     | 0 | 1     | 13            |
| 8:35 PM                         | 0                             | 0    | 0     | 0 | 0                             | 0    | 0     | 0 | 0                      | 0    | 0     | 0 | 0                      | 0    | 0     | 0 | 0     | 12            |
| 8:40 PM                         | 0                             | 0    | 0     | 0 | 0                             | 0    | 0     | 0 | 0                      | 0    | 0     | 0 | 1                      | 0    | 0     | 0 | 1     | 11            |
| 8:45 PM                         | 0                             | 0    | 0     | 0 | 0                             | 0    | 0     | 0 | 0                      | 0    | 0     | 0 | 0                      | 0    | 0     | 0 | 0     | 7             |
| 8:50 PM                         | 0                             | 0    | 0     | 0 | 1                             | 0    | 0     | 0 | 0                      | 0    | 0     | 0 | 0                      | 0    | 1     | 0 | 2     | 9             |
| 8:55 PM                         | 0                             | 0    | 0     | 0 | 0                             | 0    | 0     | 0 | 0                      | 0    | 0     | 0 | 0                      | 0    | 0     | 0 | 0     | 9             |
| 9:00 PM                         | 0                             | 1    | 0     | 0 | 1                             | 0    | 0     | 0 | 0                      | 0    | 0     | 0 | 0                      | 0    | 0     | 0 | 2     | 10            |
| 9:05 PM                         | 0                             | 0    | 0     | 0 | 0                             | 0    | 0     | 0 | 0                      | 0    | 0     | 0 | 1                      | 0    | 0     | 0 | 1     | 10            |
| 9:10 PM                         | 0                             | 0    | 0     | 0 | 0                             | 0    | 0     | 0 | 0                      | 0    | 0     | 0 | 2                      | 0    | 1     | 0 | 3     | 12            |
| 9:15 PM                         | 0                             | 0    | 1     | 0 | 0                             | 0    | 0     | 0 | 0                      | 0    | 0     | 0 | 0                      | 0    | 1     | 0 | 2     | 14            |
| 9:20 PM                         | 0                             | 0    | 0     | 0 | 0                             | 0    | 0     | 0 | 0                      | 0    | 0     | 0 | 1                      | 0    | 1     | 0 | 2     | 16            |
| 9:25 PM                         | 0                             | 0    | 0     | 0 | 0                             | 1    | 0     | 0 | 0                      | 0    | 0     | 0 | 0                      | 0    | 0     | 0 | 1     | 15            |
| 9:30 PM                         | 0                             | 1    | 0     | 0 | 0                             | 1    | 0     | 0 | 0                      | 0    | 0     | 0 | 0                      | 0    | 0     | 0 | 2     | 16            |
| 9:35 PM                         | 0                             | 0    | 0     | 0 | 0                             | 0    | 0     | 0 | 0                      | 0    | 0     | 0 | 0                      | 0    | 0     | 0 | 0     | 16            |
| 9:40 PM                         | 0                             | 0    | 0     | 0 | 0                             | 0    | 0     | 0 | 0                      | 0    | 0     | 0 | 0                      | 0    | 0     | 0 | 0     | 15            |
| 9:45 PM                         | 0                             | 0    | 0     | 0 | 0                             | 0    | 0     | 0 | 0                      | 0    | 0     | 0 | 0                      | 0    | 0     | 0 | 0     | 15            |
| 9:50 PM                         | 0                             | 0    | 0     | 0 | 0                             | 0    | 0     | 0 | 0                      | 0    | 0     | 0 | 0                      | 0    | 0     | 0 | 0     | 13            |
| 9:55 PM                         | 0                             | 0    | 0     | 0 | 0                             | 0    | 0     | 0 | 0                      | 0    | 0     | 0 | 0                      | 0    | 0     | 0 | 0     | 13            |
| Peak 15-Min Flowrates           | Northbound                    |      |       |   | Southbound                    |      |       |   | Eastbound              |      |       |   | Westbound              |      |       |   | Total |               |
|                                 | Left                          | Thru | Right | U | Left                          | Thru | Right | U | Left                   | Thru | Right | U | Left                   | Thru | Right | U |       |               |
| All Vehicles                    | 0                             | 4    | 12    | 0 | 52                            | 16   | 20    | 0 | 4                      | 4    | 0     | 0 | 16                     | 0    | 8     | 0 | 136   |               |
| Heavy Trucks                    | 0                             | 0    | 0     | 0 | 0                             | 0    | 0     | 0 | 0                      | 0    | 0     | 0 | 0                      | 0    | 0     | 0 | 0     |               |
| Buses                           |                               |      |       |   |                               |      |       |   |                        |      |       |   |                        |      |       |   |       |               |
| Pedestrians                     |                               | 16   |       |   |                               | 64   |       |   |                        | 0    |       |   |                        | 44   |       |   | 124   |               |
| Bicycles                        | 0                             | 0    | 0     |   | 0                             | 0    | 0     |   | 0                      | 0    | 0     |   | 0                      | 0    | 0     |   | 0     |               |
| Scoters                         |                               |      |       |   |                               |      |       |   |                        |      |       |   |                        |      |       |   |       |               |
| <i>Comments:</i>                |                               |      |       |   |                               |      |       |   |                        |      |       |   |                        |      |       |   |       |               |

LOCATION: Woodlawn Ave -- Kenneth Dr  
 CITY/STATE: North Tustin, CA

QC JOB #: 16966441  
 DATE: Thu, Apr 10 2025

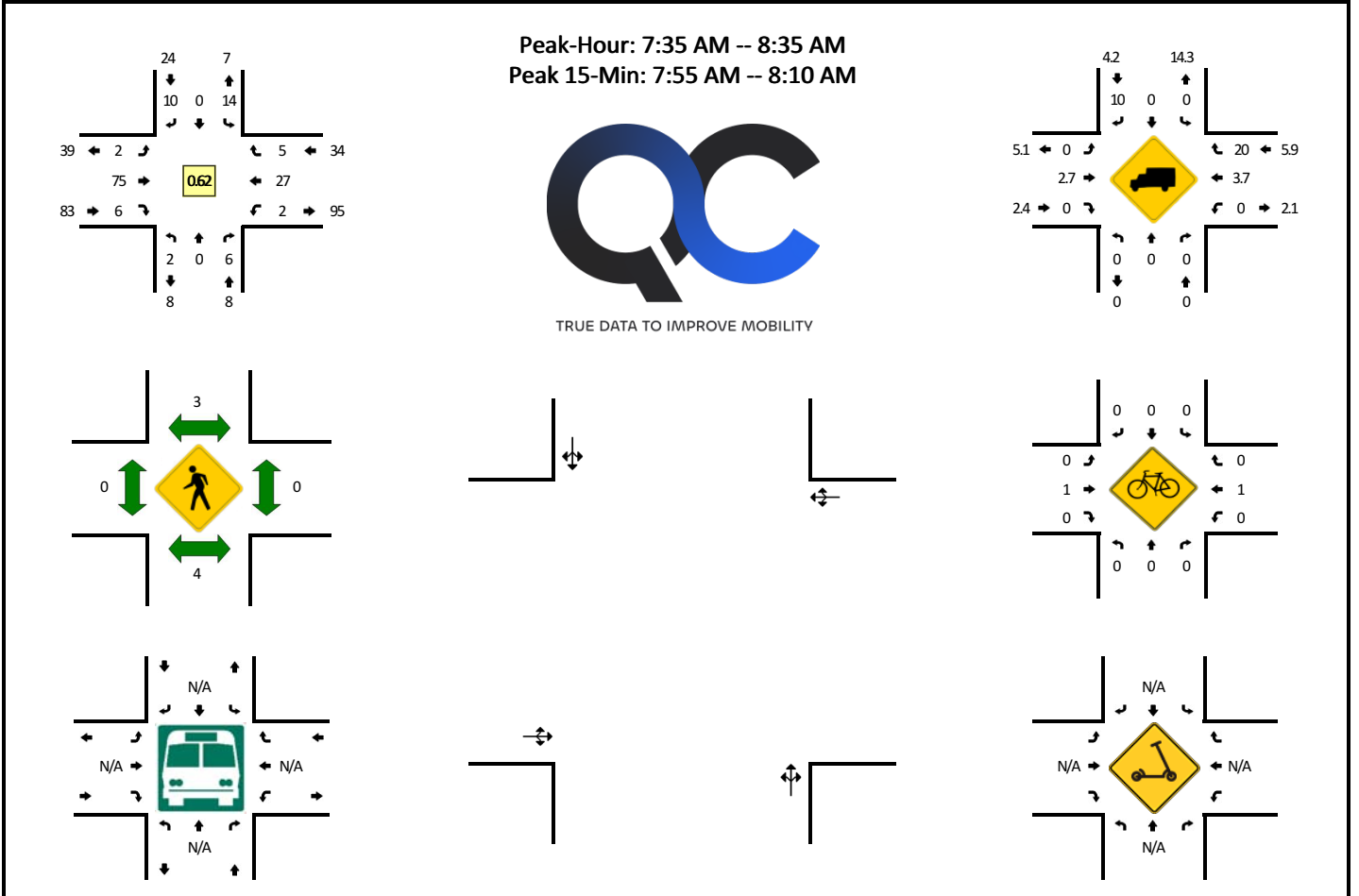

| 5-Min Count Period Beginning At | Woodlawn Ave (Northbound) |      |       |   | Woodlawn Ave (Southbound) |      |       |   | Kenneth Dr (Eastbound) |      |       |   | Kenneth Dr (Westbound) |      |       |   | Total | Hourly Totals |
|---------------------------------|---------------------------|------|-------|---|---------------------------|------|-------|---|------------------------|------|-------|---|------------------------|------|-------|---|-------|---------------|
|                                 | Left                      | Thru | Right | U | Left                      | Thru | Right | U | Left                   | Thru | Right | U | Left                   | Thru | Right | U |       |               |
| 6:00 AM                         | 0                         | 0    | 1     | 0 | 0                         | 1    | 0     | 0 | 0                      | 0    | 0     | 0 | 0                      | 0    | 0     | 0 | 2     |               |
| 6:05 AM                         | 0                         | 0    | 0     | 0 | 0                         | 0    | 0     | 0 | 0                      | 0    | 1     | 0 | 0                      | 0    | 1     | 0 | 2     |               |
| 6:10 AM                         | 0                         | 0    | 0     | 0 | 0                         | 0    | 0     | 0 | 0                      | 0    | 2     | 0 | 0                      | 0    | 1     | 0 | 3     |               |
| 6:15 AM                         | 0                         | 0    | 0     | 0 | 2                         | 0    | 0     | 0 | 0                      | 0    | 1     | 0 | 0                      | 0    | 0     | 0 | 3     |               |
| 6:20 AM                         | 0                         | 0    | 1     | 0 | 0                         | 0    | 0     | 0 | 0                      | 0    | 0     | 0 | 0                      | 0    | 0     | 0 | 1     |               |
| 6:25 AM                         | 1                         | 0    | 0     | 0 | 0                         | 0    | 0     | 0 | 0                      | 0    | 2     | 0 | 0                      | 0    | 0     | 0 | 3     |               |
| 6:30 AM                         | 0                         | 0    | 0     | 0 | 0                         | 0    | 0     | 0 | 0                      | 0    | 1     | 0 | 0                      | 0    | 0     | 0 | 1     |               |
| 6:35 AM                         | 0                         | 0    | 0     | 0 | 0                         | 0    | 1     | 0 | 0                      | 0    | 2     | 0 | 0                      | 0    | 0     | 0 | 3     |               |
| 6:40 AM                         | 0                         | 0    | 1     | 0 | 1                         | 0    | 0     | 0 | 0                      | 0    | 0     | 1 | 0                      | 0    | 0     | 0 | 3     |               |
| 6:45 AM                         | 0                         | 0    | 0     | 0 | 0                         | 0    | 0     | 0 | 0                      | 0    | 0     | 0 | 0                      | 0    | 0     | 0 | 0     |               |
| 6:50 AM                         | 0                         | 0    | 0     | 0 | 0                         | 0    | 0     | 0 | 0                      | 0    | 2     | 0 | 0                      | 0    | 0     | 0 | 2     |               |
| 6:55 AM                         | 0                         | 0    | 1     | 0 | 0                         | 0    | 0     | 0 | 0                      | 0    | 2     | 0 | 0                      | 0    | 1     | 0 | 4     | 27            |
| 7:00 AM                         | 0                         | 0    | 0     | 0 | 0                         | 0    | 1     | 0 | 0                      | 0    | 3     | 0 | 0                      | 0    | 0     | 0 | 4     | 29            |
| 7:05 AM                         | 3                         | 0    | 0     | 0 | 0                         | 0    | 0     | 0 | 0                      | 1    | 2     | 0 | 0                      | 0    | 0     | 0 | 6     | 33            |
| 7:10 AM                         | 0                         | 0    | 0     | 0 | 0                         | 0    | 0     | 0 | 0                      | 0    | 1     | 0 | 0                      | 0    | 0     | 0 | 1     | 31            |
| 7:15 AM                         | 2                         | 0    | 0     | 0 | 0                         | 0    | 0     | 0 | 0                      | 5    | 0     | 0 | 0                      | 2    | 0     | 0 | 9     | 37            |
| 7:20 AM                         | 0                         | 0    | 0     | 0 | 0                         | 0    | 1     | 0 | 0                      | 3    | 2     | 0 | 0                      | 1    | 0     | 0 | 7     | 43            |
| 7:25 AM                         | 0                         | 0    | 0     | 0 | 0                         | 0    | 0     | 0 | 0                      | 5    | 0     | 0 | 0                      | 0    | 0     | 0 | 5     | 45            |
| 7:30 AM                         | 0                         | 0    | 0     | 0 | 0                         | 0    | 0     | 0 | 0                      | 2    | 0     | 0 | 0                      | 2    | 0     | 0 | 4     | 48            |
| 7:35 AM                         | 0                         | 0    | 0     | 0 | 4                         | 0    | 0     | 0 | 0                      | 4    | 0     | 0 | 0                      | 2    | 0     | 0 | 10    | 55            |
| 7:40 AM                         | 0                         | 0    | 0     | 0 | 0                         | 0    | 0     | 0 | 0                      | 6    | 0     | 0 | 0                      | 2    | 0     | 0 | 8     | 60            |
| 7:45 AM                         | 1                         | 0    | 0     | 0 | 1                         | 0    | 1     | 0 | 0                      | 3    | 1     | 0 | 0                      | 0    | 0     | 0 | 7     | 67            |
| 7:50 AM                         | 0                         | 0    | 1     | 0 | 1                         | 0    | 0     | 0 | 0                      | 3    | 0     | 0 | 0                      | 0    | 1     | 0 | 6     | 71            |
| 7:55 AM                         | 0                         | 0    | 1     | 0 | 0                         | 0    | 4     | 0 | 0                      | 13   | 1     | 0 | 0                      | 3    | 1     | 0 | 23    | 90            |
| 8:00 AM                         | 1                         | 0    | 0     | 0 | 0                         | 0    | 0     | 0 | 0                      | 11   | 1     | 0 | 0                      | 6    | 0     | 0 | 19    | 105           |
| 8:05 AM                         | 0                         | 0    | 0     | 0 | 2                         | 0    | 0     | 0 | 0                      | 1    | 10    | 0 | 0                      | 4    | 1     | 0 | 18    | 117           |
| 8:10 AM                         | 0                         | 0    | 1     | 0 | 2                         | 0    | 2     | 0 | 0                      | 11   | 0     | 0 | 0                      | 2    | 1     | 0 | 19    | 135           |
| 8:15 AM                         | 0                         | 0    | 0     | 0 | 0                         | 0    | 1     | 0 | 0                      | 4    | 0     | 0 | 0                      | 3    | 0     | 0 | 10    | 136           |
| 8:20 AM                         | 0                         | 0    | 0     | 0 | 2                         | 0    | 2     | 0 | 0                      | 1    | 4     | 1 | 0                      | 2    | 0     | 0 | 12    | 141           |
| 8:25 AM                         | 0                         | 0    | 2     | 0 | 2                         | 0    | 0     | 0 | 0                      | 3    | 2     | 0 | 0                      | 1    | 1     | 0 | 11    | 147           |
| 8:30 AM                         | 0                         | 0    | 1     | 0 | 0                         | 0    | 0     | 0 | 0                      | 3    | 0     | 0 | 0                      | 2    | 0     | 0 | 6     | 149           |
| 8:35 AM                         | 0                         | 1    | 0     | 0 | 0                         | 1    | 0     | 0 | 0                      | 4    | 1     | 0 | 0                      | 0    | 0     | 0 | 7     | 146           |
| 8:40 AM                         | 1                         | 0    | 0     | 0 | 0                         | 0    | 0     | 0 | 0                      | 3    | 0     | 0 | 0                      | 0    | 0     | 0 | 4     | 142           |
| 8:45 AM                         | 0                         | 0    | 3     | 0 | 1                         | 0    | 0     | 0 | 0                      | 1    | 0     | 0 | 0                      | 0    | 1     | 0 | 6     | 141           |
| 8:50 AM                         | 2                         | 0    | 0     | 0 | 0                         | 0    | 0     | 0 | 0                      | 3    | 0     | 0 | 0                      | 3    | 0     | 0 | 8     | 143           |
| 8:55 AM                         | 1                         | 0    | 1     | 0 | 0                         | 0    | 0     | 0 | 0                      | 1    | 0     | 0 | 0                      | 4    | 1     | 0 | 9     | 129           |
| 9:00 AM                         | 0                         | 0    | 0     | 0 | 0                         | 0    | 0     | 0 | 0                      | 5    | 0     | 0 | 0                      | 1    | 1     | 0 | 7     | 117           |
| 9:05 AM                         | 0                         | 0    | 0     | 0 | 0                         | 0    | 1     | 0 | 0                      | 1    | 0     | 0 | 0                      | 2    | 1     | 0 | 5     | 104           |

Attachment B

| 5-Min Count Period Beginning At | Woodlawn Ave (Northbound) |      |       |   | Woodlawn Ave (Southbound) |      |       |   | Kenneth Dr (Eastbound) |      |       |   | Kenneth Dr (Westbound) |      |       |   | Total | Hourly Totals |
|---------------------------------|---------------------------|------|-------|---|---------------------------|------|-------|---|------------------------|------|-------|---|------------------------|------|-------|---|-------|---------------|
|                                 | Left                      | Thru | Right | U | Left                      | Thru | Right | U | Left                   | Thru | Right | U | Left                   | Thru | Right | U |       |               |
| 9:10 AM                         | 0                         | 0    | 0     | 0 | 1                         | 0    | 0     | 0 | 1                      | 1    | 2     | 0 | 0                      | 1    | 1     | 0 | 7     | 92            |
| 9:15 AM                         | 0                         | 0    | 1     | 0 | 0                         | 1    | 0     | 0 | 1                      | 3    | 0     | 0 | 0                      | 2    | 0     | 0 | 8     | 90            |
| 9:20 AM                         | 0                         | 0    | 0     | 0 | 1                         | 0    | 0     | 0 | 0                      | 1    | 1     | 0 | 0                      | 2    | 0     | 0 | 5     | 83            |
| 9:25 AM                         | 1                         | 0    | 0     | 0 | 1                         | 0    | 2     | 0 | 0                      | 3    | 1     | 0 | 0                      | 2    | 0     | 0 | 10    | 82            |
| 9:30 AM                         | 0                         | 0    | 0     | 0 | 0                         | 0    | 0     | 0 | 0                      | 0    | 0     | 0 | 0                      | 1    | 0     | 0 | 1     | 77            |
| 9:35 AM                         | 0                         | 0    | 1     | 0 | 0                         | 0    | 0     | 0 | 0                      | 2    | 0     | 0 | 0                      | 0    | 0     | 0 | 3     | 73            |
| 9:40 AM                         | 0                         | 0    | 0     | 0 | 0                         | 0    | 0     | 0 | 0                      | 1    | 0     | 0 | 0                      | 1    | 0     | 0 | 2     | 71            |
| 9:45 AM                         | 0                         | 0    | 0     | 0 | 1                         | 0    | 2     | 0 | 0                      | 2    | 0     | 0 | 0                      | 1    | 0     | 0 | 6     | 71            |
| 9:50 AM                         | 0                         | 0    | 0     | 0 | 0                         | 0    | 0     | 0 | 0                      | 2    | 0     | 0 | 1                      | 0    | 0     | 0 | 3     | 66            |
| 9:55 AM                         | 0                         | 0    | 0     | 0 | 0                         | 1    | 0     | 0 | 0                      | 0    | 0     | 0 | 0                      | 1    | 0     | 0 | 2     | 59            |
| 10:00 AM                        | 0                         | 0    | 0     | 0 | 0                         | 0    | 0     | 0 | 0                      | 0    | 0     | 0 | 1                      | 0    | 0     | 0 | 1     | 53            |
| 10:05 AM                        | 0                         | 1    | 2     | 0 | 1                         | 0    | 0     | 0 | 1                      | 0    | 2     | 0 | 0                      | 2    | 1     | 0 | 10    | 58            |
| 10:10 AM                        | 0                         | 0    | 0     | 0 | 1                         | 0    | 0     | 0 | 0                      | 11   | 0     | 0 | 0                      | 0    | 0     | 0 | 12    | 63            |
| 10:15 AM                        | 0                         | 0    | 0     | 0 | 1                         | 0    | 0     | 0 | 0                      | 1    | 1     | 0 | 0                      | 1    | 1     | 0 | 5     | 60            |
| 10:20 AM                        | 0                         | 0    | 0     | 0 | 1                         | 0    | 0     | 0 | 0                      | 1    | 0     | 0 | 0                      | 2    | 0     | 0 | 4     | 59            |
| 10:25 AM                        | 0                         | 0    | 0     | 0 | 2                         | 0    | 1     | 0 | 0                      | 2    | 0     | 0 | 0                      | 2    | 0     | 0 | 7     | 56            |
| 10:30 AM                        | 0                         | 0    | 0     | 0 | 0                         | 0    | 0     | 0 | 0                      | 0    | 0     | 0 | 1                      | 2    | 0     | 0 | 3     | 58            |
| 10:35 AM                        | 0                         | 0    | 0     | 0 | 2                         | 0    | 0     | 0 | 0                      | 1    | 0     | 0 | 1                      | 1    | 0     | 0 | 5     | 60            |
| 10:40 AM                        | 0                         | 0    | 1     | 0 | 0                         | 0    | 0     | 0 | 1                      | 0    | 0     | 0 | 0                      | 1    | 1     | 0 | 4     | 62            |
| 10:45 AM                        | 0                         | 0    | 0     | 0 | 0                         | 0    | 1     | 0 | 0                      | 3    | 0     | 0 | 0                      | 2    | 1     | 0 | 7     | 63            |
| 10:50 AM                        | 0                         | 0    | 1     | 0 | 1                         | 0    | 0     | 0 | 0                      | 1    | 0     | 0 | 0                      | 1    | 1     | 0 | 5     | 65            |
| 10:55 AM                        | 0                         | 0    | 0     | 0 | 0                         | 0    | 0     | 0 | 0                      | 0    | 0     | 0 | 0                      | 0    | 1     | 0 | 1     | 64            |
| 11:00 AM                        | 0                         | 0    | 1     | 0 | 1                         | 0    | 1     | 0 | 3                      | 2    | 0     | 0 | 1                      | 1    | 0     | 0 | 10    | 73            |
| 11:05 AM                        | 0                         | 0    | 1     | 0 | 2                         | 0    | 1     | 0 | 0                      | 2    | 0     | 0 | 0                      | 2    | 0     | 0 | 8     | 71            |
| 11:10 AM                        | 1                         | 0    | 0     | 0 | 1                         | 0    | 0     | 0 | 0                      | 0    | 0     | 0 | 0                      | 0    | 0     | 0 | 2     | 61            |
| 11:15 AM                        | 0                         | 0    | 0     | 0 | 0                         | 0    | 0     | 0 | 1                      | 0    | 1     | 0 | 0                      | 0    | 0     | 0 | 2     | 58            |
| 11:20 AM                        | 0                         | 0    | 0     | 0 | 1                         | 0    | 2     | 0 | 1                      | 0    | 0     | 0 | 0                      | 2    | 0     | 0 | 6     | 60            |
| 11:25 AM                        | 0                         | 0    | 0     | 0 | 0                         | 0    | 1     | 0 | 0                      | 2    | 0     | 0 | 0                      | 2    | 0     | 0 | 5     | 58            |
| 11:30 AM                        | 0                         | 0    | 0     | 0 | 1                         | 0    | 0     | 0 | 0                      | 6    | 0     | 0 | 0                      | 1    | 0     | 0 | 8     | 63            |
| 11:35 AM                        | 0                         | 0    | 0     | 0 | 0                         | 0    | 0     | 0 | 0                      | 1    | 0     | 0 | 0                      | 0    | 1     | 0 | 2     | 60            |
| 11:40 AM                        | 0                         | 0    | 0     | 0 | 0                         | 0    | 0     | 0 | 0                      | 1    | 0     | 0 | 1                      | 0    | 1     | 0 | 3     | 59            |
| 11:45 AM                        | 0                         | 0    | 0     | 0 | 0                         | 0    | 1     | 0 | 0                      | 3    | 0     | 0 | 0                      | 0    | 1     | 0 | 5     | 57            |
| 11:50 AM                        | 0                         | 0    | 0     | 0 | 0                         | 0    | 0     | 0 | 1                      | 3    | 0     | 0 | 0                      | 1    | 0     | 0 | 5     | 57            |
| 11:55 AM                        | 1                         | 0    | 3     | 0 | 1                         | 0    | 0     | 0 | 0                      | 1    | 1     | 0 | 0                      | 0    | 1     | 0 | 8     | 64            |
| 12:00 PM                        | 1                         | 0    | 0     | 0 | 0                         | 0    | 0     | 0 | 0                      | 2    | 0     | 0 | 0                      | 0    | 0     | 0 | 3     | 57            |
| 12:05 PM                        | 0                         | 0    | 0     | 0 | 0                         | 0    | 0     | 0 | 0                      | 2    | 1     | 0 | 1                      | 0    | 0     | 0 | 4     | 53            |
| 12:10 PM                        | 0                         | 0    | 0     | 0 | 0                         | 0    | 0     | 0 | 0                      | 3    | 0     | 0 | 1                      | 0    | 2     | 0 | 6     | 57            |
| 12:15 PM                        | 0                         | 1    | 0     | 0 | 0                         | 0    | 0     | 0 | 1                      | 3    | 0     | 0 | 1                      | 1    | 0     | 0 | 7     | 62            |
| 12:20 PM                        | 0                         | 0    | 1     | 0 | 1                         | 0    | 0     | 0 | 1                      | 3    | 0     | 0 | 0                      | 1    | 0     | 0 | 7     | 63            |
| 12:25 PM                        | 0                         | 0    | 0     | 0 | 0                         | 0    | 0     | 0 | 1                      | 2    | 0     | 0 | 0                      | 2    | 0     | 0 | 5     | 63            |
| 12:30 PM                        | 0                         | 0    | 0     | 0 | 0                         | 0    | 0     | 0 | 0                      | 2    | 0     | 0 | 0                      | 0    | 0     | 0 | 2     | 57            |
| 12:35 PM                        | 0                         | 0    | 0     | 0 | 1                         | 0    | 0     | 0 | 0                      | 5    | 0     | 0 | 0                      | 1    | 0     | 0 | 7     | 62            |
| 12:40 PM                        | 0                         | 0    | 0     | 0 | 1                         | 0    | 0     | 0 | 0                      | 1    | 0     | 0 | 1                      | 0    | 1     | 0 | 4     | 63            |
| 12:45 PM                        | 0                         | 0    | 0     | 0 | 0                         | 0    | 0     | 0 | 0                      | 0    | 0     | 0 | 0                      | 0    | 0     | 0 | 0     | 58            |
| 12:50 PM                        | 0                         | 0    | 0     | 0 | 0                         | 0    | 0     | 0 | 0                      | 0    | 0     | 0 | 0                      | 1    | 0     | 0 | 1     | 54            |
| 12:55 PM                        | 0                         | 0    | 0     | 0 | 1                         | 0    | 1     | 0 | 1                      | 3    | 0     | 0 | 0                      | 0    | 0     | 0 | 6     | 52            |
| 1:00 PM                         | 0                         | 0    | 0     | 0 | 0                         | 0    | 0     | 0 | 0                      | 0    | 0     | 0 | 0                      | 1    | 0     | 0 | 1     | 50            |
| 1:05 PM                         | 0                         | 0    | 0     | 0 | 1                         | 0    | 0     | 0 | 0                      | 1    | 0     | 0 | 0                      | 2    | 0     | 0 | 4     | 50            |
| 1:10 PM                         | 0                         | 0    | 0     | 0 | 0                         | 0    | 0     | 0 | 0                      | 1    | 0     | 0 | 0                      | 0    | 0     | 0 | 1     | 45            |
| 1:15 PM                         | 0                         | 0    | 0     | 0 | 0                         | 0    | 0     | 0 | 2                      | 5    | 0     | 0 | 0                      | 0    | 0     | 0 | 7     | 45            |
| 1:20 PM                         | 1                         | 0    | 0     | 0 | 0                         | 0    | 0     | 0 | 0                      | 7    | 0     | 0 | 0                      | 2    | 0     | 0 | 10    | 48            |
| 1:25 PM                         | 0                         | 0    | 0     | 0 | 0                         | 0    | 1     | 0 | 0                      | 4    | 0     | 0 | 1                      | 0    | 1     | 0 | 7     | 50            |
| 1:30 PM                         | 0                         | 0    | 1     | 0 | 0                         | 0    | 0     | 0 | 0                      | 4    | 1     | 0 | 0                      | 0    | 2     | 0 | 8     | 56            |
| 1:35 PM                         | 1                         | 0    | 0     | 0 | 1                         | 0    | 1     | 0 | 0                      | 2    | 0     | 0 | 0                      | 0    | 0     | 0 | 5     | 54            |
| 1:40 PM                         | 1                         | 0    | 0     | 0 | 0                         | 0    | 0     | 0 | 0                      | 1    | 0     | 0 | 0                      | 1    | 0     | 0 | 3     | 53            |
| 1:45 PM                         | 0                         | 0    | 0     | 0 | 0                         | 0    | 0     | 0 | 1                      | 1    | 0     | 0 | 0                      | 5    | 2     | 0 | 9     | 62            |
| 1:50 PM                         | 0                         | 0    | 0     | 0 | 0                         | 0    | 0     | 0 | 0                      | 0    | 0     | 0 | 0                      | 2    | 1     | 0 | 3     | 64            |
| 1:55 PM                         | 2                         | 0    | 0     | 0 | 0                         | 0    | 1     | 0 | 0                      | 2    | 0     | 0 | 0                      | 3    | 1     | 0 | 9     | 67            |
| 2:00 PM                         | 0                         | 0    | 0     | 0 | 0                         | 0    | 1     | 0 | 0                      | 2    | 0     | 0 | 0                      | 1    | 0     | 0 | 4     | 70            |
| 2:05 PM                         | 0                         | 0    | 0     | 0 | 1                         | 0    | 0     | 0 | 1                      | 2    | 1     | 0 | 0                      | 1    | 1     | 0 | 7     | 73            |
| 2:10 PM                         | 0                         | 0    | 0     | 0 | 0                         | 0    | 0     | 0 | 0                      | 0    | 0     | 0 | 0                      | 1    | 1     | 0 | 2     | 74            |
| 2:15 PM                         | 0                         | 0    | 0     | 0 | 0                         | 0    | 0     | 0 | 0                      | 4    | 0     | 0 | 0                      | 1    | 0     | 0 | 5     | 72            |
| 2:20 PM                         | 0                         | 0    | 1     | 0 | 1                         | 0    | 0     | 0 | 0                      | 0    | 0     | 0 | 0                      | 0    | 0     | 0 | 2     | 64            |
| 2:25 PM                         | 1                         | 0    | 0     | 0 | 1                         | 1    | 0     | 0 | 0                      | 3    | 0     | 0 | 0                      | 0    | 3     | 0 | 9     | 66            |
| 2:30 PM                         | 0                         | 0    | 1     | 0 | 1                         | 1    | 1     | 0 | 0                      | 2    | 0     | 0 | 0                      | 3    | 1     | 0 | 10    | 68            |
| 2:35 PM                         | 1                         | 0    | 0     | 0 | 0                         | 0    | 0     | 0 | 1                      | 3    | 1     | 0 | 1                      | 2    | 0     | 0 | 9     | 72            |
| 2:40 PM                         | 0                         | 1    | 1     | 0 | 2                         | 0    | 0     | 0 | 0                      | 15   | 0     | 0 | 2                      | 2    | 0     | 0 | 23    | 92            |
| 2:45 PM                         | 1                         | 0    | 0     | 0 | 0                         | 0    | 0     | 0 | 0                      | 12   | 1     | 0 | 1                      | 2    | 0     | 0 | 17    | 100           |
| 2:50 PM                         | 0                         | 0    | 0     | 0 | 0                         | 0    | 0     | 0 | 0                      | 2    | 0     | 0 | 0                      | 1    | 0     | 0 | 3     | 100           |
| 2:55 PM                         | 0                         | 0    | 0     | 0 | 0                         | 0    | 0     | 0 | 0                      | 2    | 0     | 0 | 0                      | 2    | 1     | 0 | 5     | 96            |
| 3:00 PM                         | 0                         | 0    | 0     | 0 | 0                         | 0    | 0     | 0 | 0                      | 2    | 0     | 0 | 0                      | 3    | 0     | 0 | 5     | 97            |
| 3:05 PM                         | 0                         | 0    | 1     | 0 | 0                         | 0    | 0     | 0 | 0                      | 1    | 1     | 0 | 0                      | 1    | 0     | 0 | 4     | 94            |
| 3:10 PM                         | 1                         | 0    | 0     | 0 | 0                         | 0    | 0     | 0 | 0                      | 2    | 0     | 0 | 0                      | 0    | 1     | 0 | 4     | 96            |
| 3:15 PM                         | 0                         | 1    | 1     | 0 | 0                         | 0    | 0     | 0 | 0                      | 1    | 2     | 0 | 0                      | 1    | 0     | 0 | 6     | 97            |
| 3:20 PM                         | 0                         | 0    | 0     | 0 | 0                         | 0    | 0     | 0 | 0                      | 3    | 0     | 0 | 0                      | 1    | 0     | 0 | 4     | 99            |
| 3:25 PM                         | 0                         | 0    | 0     | 0 | 0                         | 0    | 0     | 0 | 0                      | 6    | 0     | 0 | 0                      | 0    | 1     | 0 | 7     | 97            |
| 3:30 PM                         | 0                         | 0    | 0     | 0 | 0                         | 1    | 0     | 0 | 0                      | 1    | 0     | 0 | 0                      | 0    | 0     | 0 | 2     | 89            |
| 3:35 PM                         | 1                         | 1    | 0     | 0 | 0                         | 0    | 2     | 0 | 1                      | 5    | 1     | 0 | 0                      | 2    | 1     | 0 | 14    | 94            |
| 3:40 PM                         | 1                         | 0    | 0     | 0 | 0                         | 0    | 0     | 0 | 1                      | 6    | 0     | 0 | 0                      | 4    | 1     | 0 | 13    | 84            |
| 3:45 PM                         | 1                         | 0    | 0     | 0 | 0                         | 0    | 0     | 0 | 0                      | 5    | 0     | 0 | 0                      | 4    | 0     | 0 | 10    | 77            |
| 3:50 PM                         | 0                         | 0    | 0     | 0 | 3                         | 0    | 0     | 0 | 0                      | 6    | 0     | 0 | 1                      | 1    | 0     | 0 | 11    | 85            |
| 3:55 PM                         | 0                         | 0    | 0     | 0 | 0                         | 0    | 0     | 0 | 1                      | 5    | 0     | 0 | 0                      | 1    | 0     | 0 | 7     | 87            |
| 4:00 PM                         | 0                         | 0    | 0     | 0 | 0                         | 0    | 0     | 0 | 1                      | 2    | 1     | 0 | 2                      | 1    | 0     | 0 | 7     | 89            |
| 4:05 PM                         | 0                         | 0    | 0     | 0 | 1                         | 0    | 1     | 0 | 0                      | 2    | 0     | 0 | 0                      | 2    | 1     | 0 | 7     | 92            |
| 4:10 PM                         | 0                         | 0    | 0     | 0 | 1                         | 0    | 1     | 0 | 0                      | 2    | 0     | 0 | 0                      | 3    | 3     | 0 | 10    | 98            |
| 4:15 PM                         | 0                         | 0    | 0     | 0 | 0                         | 0    | 1     | 0 | 0                      | 1    | 0     | 0 | 0                      | 1    | 0     | 0 | 3     | 95            |
| 4:20 PM                         | 0                         | 0    | 2     | 0 | 0                         | 0    | 1     | 0 | 0                      | 2    | 0     | 0 | 0                      | 0    | 0     | 0 | 5     | 96            |
| 4:25 PM                         | 0                         | 0    | 0     | 0 | 0                         | 0    | 0     | 0 | 0                      | 2    | 1     | 0 | 0                      | 0    | 0     | 0 | 3     | 92            |
| 4:30 PM                         | 1                         | 0    | 0     | 0 | 0                         | 0    | 0     | 0 | 1                      | 5    | 0     | 0 | 1                      | 2    | 0     | 0 | 10    | 100           |

**Attachment B**

| 5-Min Count Period Beginning At | Woodlawn Ave (Northbound) |      |       |   | Woodlawn Ave (Southbound) |      |       |   | Kenneth Dr (Eastbound) |      |       |   | Kenneth Dr (Westbound) |      |       |   | Total | Hourly Totals |
|---------------------------------|---------------------------|------|-------|---|---------------------------|------|-------|---|------------------------|------|-------|---|------------------------|------|-------|---|-------|---------------|
|                                 | Left                      | Thru | Right | U | Left                      | Thru | Right | U | Left                   | Thru | Right | U | Left                   | Thru | Right | U |       |               |
| 4:35 PM                         | 1                         | 0    | 0     | 0 | 0                         | 0    | 1     | 0 | 0                      | 0    | 0     | 0 | 0                      | 5    | 0     | 0 | 7     | 93            |
| 4:40 PM                         | 0                         | 0    | 0     | 0 | 0                         | 0    | 0     | 0 | 0                      | 3    | 0     | 0 | 0                      | 4    | 0     | 0 | 7     | 87            |
| 4:45 PM                         | 0                         | 0    | 0     | 0 | 1                         | 0    | 1     | 0 | 0                      | 5    | 0     | 0 | 0                      | 1    | 0     | 0 | 8     | 85            |
| 4:50 PM                         | 0                         | 0    | 0     | 0 | 1                         | 0    | 1     | 0 | 0                      | 3    | 0     | 0 | 0                      | 1    | 0     | 0 | 6     | 80            |
| 4:55 PM                         | 1                         | 0    | 0     | 0 | 0                         | 0    | 0     | 0 | 1                      | 4    | 1     | 0 | 0                      | 2    | 1     | 0 | 10    | 83            |
| 5:00 PM                         | 0                         | 0    | 0     | 0 | 0                         | 0    | 0     | 0 | 0                      | 4    | 0     | 0 | 1                      | 2    | 0     | 0 | 7     | 83            |
| 5:05 PM                         | 0                         | 0    | 0     | 0 | 1                         | 0    | 1     | 0 | 1                      | 3    | 0     | 0 | 0                      | 1    | 0     | 0 | 7     | 83            |
| 5:10 PM                         | 1                         | 0    | 0     | 0 | 0                         | 0    | 1     | 0 | 0                      | 1    | 1     | 0 | 0                      | 2    | 3     | 0 | 9     | 82            |
| 5:15 PM                         | 1                         | 0    | 0     | 0 | 0                         | 0    | 1     | 0 | 3                      | 4    | 0     | 0 | 0                      | 0    | 0     | 0 | 9     | 88            |
| 5:20 PM                         | 0                         | 0    | 0     | 0 | 1                         | 0    | 0     | 0 | 0                      | 4    | 1     | 0 | 0                      | 1    | 1     | 0 | 8     | 91            |
| 5:25 PM                         | 0                         | 0    | 0     | 0 | 2                         | 0    | 0     | 0 | 0                      | 4    | 1     | 0 | 0                      | 3    | 0     | 0 | 10    | 98            |
| 5:30 PM                         | 0                         | 0    | 0     | 0 | 0                         | 0    | 0     | 0 | 0                      | 4    | 0     | 0 | 0                      | 2    | 2     | 0 | 8     | 96            |
| 5:35 PM                         | 0                         | 0    | 0     | 0 | 0                         | 0    | 0     | 0 | 0                      | 4    | 0     | 0 | 0                      | 1    | 0     | 0 | 5     | 94            |
| 5:40 PM                         | 0                         | 0    | 0     | 0 | 0                         | 0    | 1     | 0 | 0                      | 1    | 0     | 0 | 0                      | 0    | 0     | 0 | 2     | 89            |
| 5:45 PM                         | 0                         | 0    | 0     | 0 | 0                         | 0    | 0     | 0 | 1                      | 3    | 1     | 0 | 0                      | 0    | 2     | 0 | 7     | 88            |
| 5:50 PM                         | 0                         | 0    | 0     | 0 | 0                         | 0    | 1     | 0 | 0                      | 2    | 0     | 0 | 1                      | 0    | 0     | 0 | 4     | 86            |
| 5:55 PM                         | 0                         | 0    | 0     | 0 | 2                         | 0    | 0     | 0 | 0                      | 2    | 0     | 0 | 0                      | 3    | 1     | 0 | 8     | 84            |
| 6:00 PM                         | 0                         | 0    | 0     | 0 | 0                         | 0    | 0     | 0 | 0                      | 0    | 0     | 0 | 0                      | 2    | 0     | 0 | 2     | 79            |
| 6:05 PM                         | 0                         | 0    | 0     | 0 | 0                         | 0    | 0     | 0 | 2                      | 5    | 0     | 0 | 0                      | 1    | 1     | 0 | 9     | 81            |
| 6:10 PM                         | 0                         | 0    | 0     | 0 | 0                         | 0    | 0     | 0 | 0                      | 3    | 0     | 0 | 0                      | 2    | 1     | 0 | 6     | 78            |
| 6:15 PM                         | 0                         | 0    | 0     | 0 | 0                         | 0    | 0     | 0 | 0                      | 4    | 0     | 0 | 1                      | 3    | 0     | 0 | 8     | 77            |
| 6:20 PM                         | 0                         | 0    | 0     | 0 | 0                         | 0    | 0     | 0 | 2                      | 2    | 0     | 0 | 0                      | 0    | 1     | 0 | 5     | 74            |
| 6:25 PM                         | 0                         | 0    | 0     | 0 | 0                         | 0    | 1     | 0 | 1                      | 5    | 1     | 0 | 0                      | 0    | 0     | 0 | 8     | 72            |
| 6:30 PM                         | 0                         | 0    | 0     | 0 | 2                         | 0    | 1     | 0 | 0                      | 0    | 0     | 0 | 0                      | 2    | 0     | 0 | 5     | 69            |
| 6:35 PM                         | 0                         | 0    | 0     | 0 | 0                         | 0    | 0     | 0 | 0                      | 0    | 0     | 0 | 0                      | 2    | 0     | 0 | 2     | 66            |
| 6:40 PM                         | 0                         | 0    | 0     | 0 | 1                         | 0    | 0     | 0 | 0                      | 3    | 0     | 0 | 0                      | 0    | 0     | 0 | 4     | 68            |
| 6:45 PM                         | 0                         | 0    | 0     | 0 | 1                         | 0    | 0     | 0 | 1                      | 2    | 1     | 0 | 0                      | 0    | 2     | 0 | 7     | 68            |
| 6:50 PM                         | 0                         | 0    | 0     | 0 | 0                         | 0    | 0     | 0 | 0                      | 1    | 2     | 0 | 0                      | 2    | 0     | 0 | 5     | 69            |
| 6:55 PM                         | 0                         | 0    | 2     | 0 | 0                         | 0    | 0     | 0 | 1                      | 3    | 0     | 0 | 0                      | 1    | 0     | 0 | 7     | 68            |
| 7:00 PM                         | 0                         | 0    | 0     | 0 | 0                         | 0    | 0     | 0 | 0                      | 3    | 0     | 0 | 0                      | 1    | 0     | 0 | 4     | 70            |
| 7:05 PM                         | 0                         | 0    | 0     | 0 | 0                         | 0    | 0     | 0 | 0                      | 2    | 0     | 0 | 0                      | 1    | 2     | 0 | 5     | 66            |
| 7:10 PM                         | 0                         | 0    | 0     | 0 | 0                         | 0    | 0     | 0 | 0                      | 0    | 0     | 0 | 0                      | 1    | 0     | 0 | 1     | 61            |
| 7:15 PM                         | 0                         | 0    | 1     | 0 | 0                         | 0    | 0     | 0 | 0                      | 0    | 1     | 0 | 0                      | 0    | 0     | 0 | 2     | 55            |
| 7:20 PM                         | 1                         | 0    | 0     | 0 | 0                         | 0    | 0     | 0 | 0                      | 0    | 1     | 0 | 1                      | 1    | 1     | 0 | 5     | 55            |
| 7:25 PM                         | 0                         | 0    | 0     | 0 | 0                         | 0    | 0     | 0 | 0                      | 2    | 0     | 0 | 0                      | 3    | 0     | 0 | 5     | 52            |
| 7:30 PM                         | 0                         | 0    | 0     | 0 | 0                         | 0    | 0     | 0 | 0                      | 0    | 1     | 0 | 1                      | 1    | 1     | 0 | 4     | 51            |
| 7:35 PM                         | 0                         | 0    | 1     | 0 | 0                         | 0    | 0     | 0 | 1                      | 0    | 0     | 0 | 0                      | 0    | 0     | 0 | 2     | 51            |
| 7:40 PM                         | 0                         | 0    | 0     | 0 | 0                         | 0    | 0     | 0 | 1                      | 3    | 0     | 0 | 0                      | 0    | 0     | 0 | 4     | 51            |
| 7:45 PM                         | 0                         | 0    | 0     | 0 | 0                         | 0    | 0     | 0 | 1                      | 1    | 0     | 0 | 1                      | 1    | 0     | 0 | 4     | 48            |
| 7:50 PM                         | 0                         | 0    | 0     | 0 | 0                         | 0    | 0     | 0 | 0                      | 2    | 0     | 0 | 0                      | 1    | 0     | 0 | 3     | 46            |
| 7:55 PM                         | 0                         | 0    | 0     | 0 | 0                         | 0    | 0     | 0 | 0                      | 0    | 0     | 0 | 0                      | 0    | 0     | 0 | 0     | 39            |
| 8:00 PM                         | 0                         | 0    | 0     | 0 | 0                         | 0    | 0     | 0 | 0                      | 0    | 1     | 0 | 0                      | 1    | 0     | 0 | 2     | 37            |
| 8:05 PM                         | 1                         | 0    | 0     | 0 | 0                         | 0    | 0     | 0 | 0                      | 1    | 0     | 0 | 0                      | 2    | 0     | 0 | 4     | 36            |
| 8:10 PM                         | 1                         | 0    | 0     | 0 | 0                         | 0    | 0     | 0 | 0                      | 0    | 0     | 0 | 0                      | 0    | 2     | 0 | 3     | 38            |
| 8:15 PM                         | 0                         | 0    | 0     | 0 | 0                         | 0    | 0     | 0 | 0                      | 2    | 1     | 0 | 0                      | 0    | 1     | 0 | 4     | 40            |
| 8:20 PM                         | 0                         | 0    | 0     | 0 | 0                         | 0    | 0     | 0 | 0                      | 2    | 0     | 0 | 0                      | 2    | 0     | 0 | 4     | 39            |
| 8:25 PM                         | 0                         | 0    | 0     | 0 | 0                         | 0    | 0     | 0 | 0                      | 0    | 0     | 0 | 0                      | 1    | 0     | 0 | 1     | 35            |
| 8:30 PM                         | 0                         | 0    | 0     | 0 | 0                         | 0    | 0     | 0 | 0                      | 2    | 1     | 0 | 0                      | 0    | 1     | 0 | 4     | 35            |
| 8:35 PM                         | 1                         | 0    | 0     | 0 | 0                         | 0    | 0     | 0 | 1                      | 2    | 0     | 0 | 0                      | 2    | 0     | 0 | 6     | 39            |
| 8:40 PM                         | 0                         | 0    | 0     | 0 | 0                         | 0    | 0     | 0 | 0                      | 1    | 0     | 0 | 0                      | 1    | 0     | 0 | 2     | 37            |
| 8:45 PM                         | 0                         | 0    | 0     | 0 | 1                         | 0    | 0     | 0 | 0                      | 0    | 0     | 0 | 0                      | 1    | 0     | 0 | 2     | 35            |
| 8:50 PM                         | 0                         | 0    | 0     | 0 | 0                         | 0    | 0     | 0 | 0                      | 2    | 0     | 0 | 0                      | 1    | 0     | 0 | 3     | 35            |
| 8:55 PM                         | 0                         | 0    | 0     | 0 | 0                         | 0    | 0     | 0 | 0                      | 1    | 0     | 0 | 0                      | 0    | 0     | 0 | 1     | 36            |
| 9:00 PM                         | 0                         | 0    | 0     | 0 | 0                         | 0    | 0     | 0 | 0                      | 0    | 0     | 0 | 0                      | 1    | 0     | 0 | 1     | 35            |
| 9:05 PM                         | 0                         | 0    | 0     | 0 | 0                         | 0    | 0     | 0 | 0                      | 0    | 0     | 0 | 0                      | 0    | 0     | 0 | 0     | 31            |
| 9:10 PM                         | 0                         | 0    | 0     | 0 | 0                         | 0    | 0     | 0 | 1                      | 2    | 0     | 0 | 0                      | 0    | 0     | 0 | 3     | 31            |
| 9:15 PM                         | 0                         | 0    | 0     | 0 | 0                         | 0    | 0     | 0 | 0                      | 0    | 0     | 0 | 0                      | 0    | 0     | 0 | 0     | 27            |
| 9:20 PM                         | 0                         | 0    | 0     | 0 | 0                         | 0    | 0     | 0 | 0                      | 2    | 0     | 0 | 0                      | 0    | 0     | 0 | 2     | 25            |
| 9:25 PM                         | 0                         | 0    | 0     | 0 | 0                         | 0    | 0     | 0 | 0                      | 0    | 0     | 0 | 1                      | 0    | 1     | 0 | 2     | 26            |
| 9:30 PM                         | 0                         | 0    | 0     | 0 | 0                         | 0    | 0     | 0 | 0                      | 0    | 0     | 0 | 0                      | 1    | 0     | 0 | 1     | 23            |
| 9:35 PM                         | 0                         | 0    | 0     | 0 | 0                         | 0    | 0     | 0 | 0                      | 1    | 0     | 0 | 0                      | 0    | 0     | 0 | 1     | 18            |
| 9:40 PM                         | 0                         | 0    | 0     | 0 | 2                         | 0    | 0     | 0 | 0                      | 1    | 1     | 0 | 0                      | 0    | 0     | 0 | 4     | 20            |
| 9:45 PM                         | 0                         | 0    | 0     | 0 | 0                         | 0    | 0     | 0 | 0                      | 0    | 0     | 0 | 0                      | 1    | 0     | 0 | 1     | 19            |
| 9:50 PM                         | 0                         | 0    | 0     | 0 | 0                         | 0    | 0     | 0 | 0                      | 0    | 1     | 0 | 0                      | 2    | 0     | 0 | 3     | 19            |
| 9:55 PM                         | 0                         | 0    | 0     | 0 | 0                         | 1    | 0     | 0 | 0                      | 0    | 0     | 0 | 0                      | 0    | 0     | 0 | 1     | 19            |
| Peak 15-Min Flowrates           | Northbound                |      |       |   | Southbound                |      |       |   | Eastbound              |      |       |   | Westbound              |      |       |   | Total |               |
|                                 | Left                      | Thru | Right | U | Left                      | Thru | Right | U | Left                   | Thru | Right | U | Left                   | Thru | Right | U |       |               |
| All Vehicles                    | 4                         | 0    | 4     | 0 | 8                         | 0    | 16    | 0 | 4                      | 136  | 8     | 0 | 0                      | 52   | 8     | 0 | 240   |               |
| Heavy Trucks                    | 0                         | 0    | 0     | 0 | 0                         | 0    | 0     | 0 | 0                      | 0    | 0     | 0 | 0                      | 4    | 4     | 0 | 8     |               |
| Buses                           |                           | 4    |       |   |                           | 8    |       |   |                        | 0    |       |   |                        | 0    |       |   | 12    |               |
| Pedestrians                     | 0                         | 0    | 0     | 0 | 0                         | 0    | 0     | 0 | 0                      | 0    | 0     | 0 | 0                      | 0    | 0     | 0 | 0     |               |
| Bicycles                        |                           |      |       |   |                           |      |       |   |                        |      |       |   |                        |      |       |   |       |               |
| Scoters                         |                           |      |       |   |                           |      |       |   |                        |      |       |   |                        |      |       |   |       |               |

Comments:

Type of peak hour being reported: Intersection Peak

Method for determining peak hour: Total Entering Volume

LOCATION: Rebecca Ln -- Gwen Ave  
CITY/STATE: North Tustin, CA

QC JOB #: 16966442  
DATE: Thu, Apr 10 2025

Peak-Hour: 1:40 PM -- 2:40 PM  
Peak 15-Min: 1:40 PM -- 1:55 PM

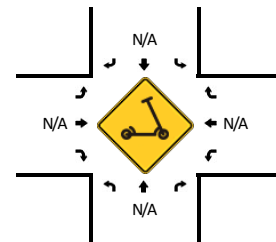
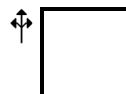
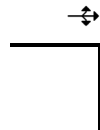
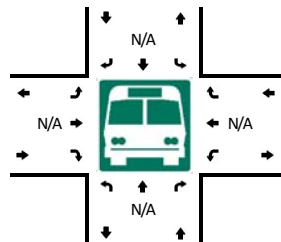
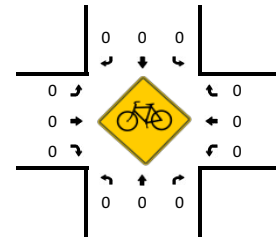
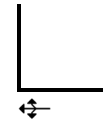
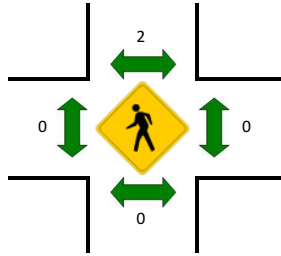
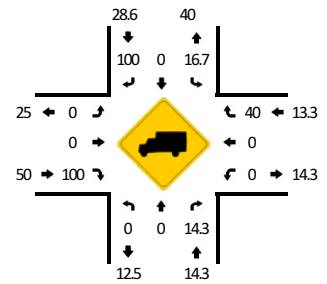
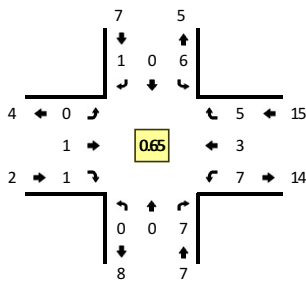

| 5-Min Count Period Beginning At | Rebecca Ln (Northbound) |      |       |   | Rebecca Ln (Southbound) |      |       |   | Gwen Ave (Eastbound) |      |       |   | Gwen Ave (Westbound) |      |       |   | Total | Hourly Totals |
|---------------------------------|-------------------------|------|-------|---|-------------------------|------|-------|---|----------------------|------|-------|---|----------------------|------|-------|---|-------|---------------|
|                                 | Left                    | Thru | Right | U | Left                    | Thru | Right | U | Left                 | Thru | Right | U | Left                 | Thru | Right | U |       |               |
| 6:00 AM                         | 0                       | 0    | 0     | 0 | 0                       | 0    | 0     | 0 | 0                    | 0    | 0     | 0 | 0                    | 0    | 0     | 0 | 0     | 0             |
| 6:05 AM                         | 0                       | 0    | 0     | 0 | 0                       | 0    | 0     | 0 | 0                    | 0    | 0     | 0 | 0                    | 0    | 0     | 0 | 0     | 0             |
| 6:10 AM                         | 0                       | 0    | 0     | 0 | 0                       | 0    | 0     | 0 | 0                    | 0    | 0     | 0 | 0                    | 0    | 0     | 0 | 0     | 0             |
| 6:15 AM                         | 0                       | 0    | 0     | 0 | 0                       | 0    | 0     | 0 | 0                    | 0    | 0     | 0 | 0                    | 0    | 0     | 0 | 0     | 0             |
| 6:20 AM                         | 0                       | 0    | 0     | 0 | 0                       | 0    | 0     | 0 | 0                    | 0    | 0     | 0 | 0                    | 0    | 0     | 0 | 0     | 0             |
| 6:25 AM                         | 0                       | 0    | 0     | 0 | 0                       | 0    | 0     | 0 | 0                    | 1    | 0     | 0 | 0                    | 1    | 0     | 0 | 0     | 2             |
| 6:30 AM                         | 0                       | 0    | 1     | 0 | 0                       | 0    | 0     | 0 | 0                    | 0    | 0     | 0 | 0                    | 0    | 0     | 0 | 0     | 1             |
| 6:35 AM                         | 0                       | 0    | 0     | 0 | 0                       | 0    | 0     | 0 | 0                    | 0    | 0     | 0 | 0                    | 0    | 0     | 0 | 0     | 0             |
| 6:40 AM                         | 0                       | 0    | 0     | 0 | 0                       | 0    | 0     | 0 | 0                    | 0    | 0     | 0 | 0                    | 0    | 0     | 0 | 0     | 0             |
| 6:45 AM                         | 0                       | 0    | 0     | 0 | 0                       | 0    | 0     | 0 | 0                    | 0    | 0     | 0 | 0                    | 0    | 0     | 0 | 0     | 0             |
| 6:50 AM                         | 0                       | 0    | 0     | 0 | 0                       | 0    | 0     | 0 | 0                    | 0    | 0     | 0 | 0                    | 0    | 0     | 0 | 0     | 0             |
| 6:55 AM                         | 0                       | 0    | 0     | 0 | 0                       | 0    | 0     | 0 | 0                    | 0    | 0     | 0 | 0                    | 0    | 0     | 0 | 0     | 0             |
| 7:00 AM                         | 0                       | 0    | 0     | 0 | 0                       | 0    | 0     | 0 | 0                    | 0    | 0     | 0 | 0                    | 0    | 0     | 0 | 0     | 3             |
| 7:05 AM                         | 0                       | 0    | 0     | 0 | 0                       | 0    | 0     | 0 | 0                    | 0    | 0     | 0 | 0                    | 0    | 0     | 0 | 0     | 3             |
| 7:10 AM                         | 0                       | 0    | 0     | 0 | 0                       | 0    | 0     | 0 | 0                    | 0    | 0     | 0 | 0                    | 0    | 0     | 0 | 0     | 3             |
| 7:15 AM                         | 0                       | 0    | 0     | 0 | 1                       | 0    | 0     | 0 | 0                    | 0    | 0     | 0 | 0                    | 0    | 0     | 0 | 1     | 4             |
| 7:20 AM                         | 0                       | 0    | 0     | 0 | 0                       | 0    | 0     | 0 | 0                    | 0    | 0     | 0 | 0                    | 0    | 0     | 0 | 0     | 4             |
| 7:25 AM                         | 0                       | 0    | 0     | 0 | 0                       | 0    | 0     | 0 | 0                    | 0    | 0     | 0 | 0                    | 0    | 0     | 0 | 0     | 2             |
| 7:30 AM                         | 0                       | 0    | 0     | 0 | 0                       | 0    | 0     | 0 | 0                    | 0    | 0     | 0 | 0                    | 0    | 0     | 0 | 1     | 1             |
| 7:35 AM                         | 0                       | 0    | 0     | 0 | 0                       | 0    | 0     | 0 | 0                    | 0    | 0     | 0 | 1                    | 0    | 0     | 0 | 1     | 2             |
| 7:40 AM                         | 0                       | 0    | 3     | 0 | 0                       | 0    | 0     | 0 | 0                    | 0    | 0     | 0 | 0                    | 0    | 1     | 0 | 4     | 6             |
| 7:45 AM                         | 0                       | 0    | 0     | 0 | 0                       | 0    | 0     | 0 | 0                    | 0    | 0     | 0 | 0                    | 0    | 0     | 0 | 0     | 6             |
| 7:50 AM                         | 0                       | 0    | 0     | 0 | 1                       | 0    | 0     | 0 | 0                    | 0    | 0     | 0 | 0                    | 0    | 0     | 0 | 1     | 7             |
| 7:55 AM                         | 0                       | 0    | 2     | 0 | 1                       | 0    | 0     | 0 | 0                    | 0    | 0     | 0 | 1                    | 0    | 0     | 0 | 4     | 11            |
| 8:00 AM                         | 0                       | 0    | 0     | 0 | 1                       | 0    | 0     | 0 | 0                    | 0    | 0     | 0 | 0                    | 0    | 0     | 0 | 1     | 12            |
| 8:05 AM                         | 0                       | 0    | 2     | 0 | 0                       | 0    | 0     | 0 | 0                    | 0    | 0     | 0 | 0                    | 0    | 0     | 0 | 2     | 14            |
| 8:10 AM                         | 0                       | 0    | 0     | 0 | 0                       | 0    | 0     | 0 | 0                    | 0    | 0     | 0 | 1                    | 0    | 1     | 0 | 2     | 16            |
| 8:15 AM                         | 0                       | 0    | 1     | 0 | 1                       | 0    | 0     | 0 | 0                    | 2    | 0     | 0 | 0                    | 0    | 0     | 0 | 4     | 19            |
| 8:20 AM                         | 0                       | 0    | 0     | 0 | 0                       | 0    | 0     | 0 | 0                    | 0    | 0     | 0 | 0                    | 1    | 0     | 0 | 1     | 20            |
| 8:25 AM                         | 0                       | 0    | 1     | 0 | 0                       | 0    | 0     | 0 | 0                    | 0    | 0     | 0 | 1                    | 0    | 0     | 0 | 2     | 22            |
| 8:30 AM                         | 0                       | 0    | 0     | 0 | 0                       | 0    | 0     | 0 | 0                    | 1    | 0     | 0 | 0                    | 0    | 0     | 0 | 1     | 23            |
| 8:35 AM                         | 0                       | 0    | 1     | 0 | 1                       | 0    | 0     | 0 | 0                    | 0    | 0     | 0 | 0                    | 0    | 1     | 0 | 3     | 25            |
| 8:40 AM                         | 0                       | 0    | 0     | 0 | 0                       | 0    | 0     | 0 | 0                    | 0    | 0     | 0 | 0                    | 0    | 0     | 0 | 0     | 21            |
| 8:45 AM                         | 0                       | 0    | 2     | 0 | 0                       | 0    | 0     | 0 | 0                    | 1    | 0     | 0 | 1                    | 1    | 0     | 0 | 5     | 26            |
| 8:50 AM                         | 0                       | 0    | 0     | 0 | 0                       | 0    | 0     | 0 | 0                    | 0    | 0     | 0 | 0                    | 0    | 0     | 0 | 0     | 25            |
| 8:55 AM                         | 0                       | 0    | 1     | 0 | 1                       | 0    | 0     | 0 | 0                    | 0    | 0     | 0 | 0                    | 1    | 0     | 0 | 3     | 24            |
| 9:00 AM                         | 0                       | 0    | 0     | 0 | 0                       | 0    | 0     | 0 | 0                    | 0    | 0     | 0 | 0                    | 0    | 0     | 0 | 0     | 23            |
| 9:05 AM                         | 0                       | 0    | 0     | 0 | 1                       | 0    | 0     | 0 | 0                    | 0    | 0     | 0 | 1                    | 0    | 0     | 0 | 2     | 23            |

Attachment B

| 5-Min Count Period Beginning At | Rebecca Ln (Northbound) |      |       |   | Rebecca Ln (Southbound) |      |       |   | Gwen Ave (Eastbound) |      |       |   | Gwen Ave (Westbound) |      |       |   | Total | Hourly Totals |
|---------------------------------|-------------------------|------|-------|---|-------------------------|------|-------|---|----------------------|------|-------|---|----------------------|------|-------|---|-------|---------------|
|                                 | Left                    | Thru | Right | U | Left                    | Thru | Right | U | Left                 | Thru | Right | U | Left                 | Thru | Right | U |       |               |
| 9:10 AM                         | 0                       | 0    | 0     | 0 | 2                       | 0    | 0     | 0 | 0                    | 0    | 0     | 0 | 0                    | 0    | 2     | 0 | 4     | 25            |
| 9:15 AM                         | 0                       | 0    | 1     | 0 | 0                       | 0    | 0     | 0 | 0                    | 0    | 0     | 0 | 0                    | 0    | 0     | 0 | 1     | 22            |
| 9:20 AM                         | 0                       | 0    | 0     | 0 | 0                       | 0    | 0     | 0 | 0                    | 0    | 0     | 0 | 0                    | 0    | 0     | 0 | 0     | 21            |
| 9:25 AM                         | 0                       | 0    | 0     | 0 | 0                       | 0    | 0     | 0 | 0                    | 0    | 0     | 0 | 0                    | 0    | 1     | 0 | 1     | 20            |
| 9:30 AM                         | 0                       | 0    | 0     | 0 | 1                       | 0    | 0     | 0 | 0                    | 0    | 1     | 0 | 0                    | 0    | 0     | 0 | 2     | 21            |
| 9:35 AM                         | 0                       | 0    | 0     | 0 | 0                       | 0    | 0     | 0 | 0                    | 0    | 0     | 0 | 1                    | 0    | 1     | 0 | 2     | 20            |
| 9:40 AM                         | 0                       | 0    | 0     | 0 | 0                       | 0    | 0     | 0 | 0                    | 0    | 0     | 0 | 0                    | 0    | 0     | 0 | 0     | 20            |
| 9:45 AM                         | 0                       | 0    | 1     | 0 | 1                       | 0    | 0     | 0 | 0                    | 0    | 0     | 0 | 0                    | 0    | 0     | 0 | 2     | 17            |
| 9:50 AM                         | 0                       | 0    | 1     | 0 | 0                       | 0    | 0     | 0 | 0                    | 0    | 0     | 0 | 0                    | 1    | 0     | 0 | 2     | 19            |
| 9:55 AM                         | 0                       | 0    | 1     | 0 | 1                       | 0    | 0     | 0 | 0                    | 0    | 0     | 0 | 0                    | 0    | 0     | 0 | 2     | 18            |
| 10:00 AM                        | 0                       | 0    | 0     | 0 | 0                       | 0    | 0     | 0 | 0                    | 0    | 0     | 0 | 0                    | 0    | 1     | 0 | 1     | 19            |
| 10:05 AM                        | 0                       | 1    | 0     | 0 | 0                       | 0    | 1     | 0 | 0                    | 0    | 1     | 0 | 2                    | 0    | 0     | 0 | 5     | 22            |
| 10:10 AM                        | 0                       | 0    | 1     | 0 | 2                       | 0    | 0     | 0 | 0                    | 0    | 0     | 0 | 1                    | 0    | 0     | 0 | 4     | 22            |
| 10:15 AM                        | 0                       | 0    | 0     | 0 | 0                       | 0    | 0     | 0 | 0                    | 0    | 0     | 0 | 0                    | 0    | 0     | 0 | 0     | 21            |
| 10:20 AM                        | 0                       | 0    | 2     | 0 | 0                       | 0    | 0     | 0 | 0                    | 0    | 0     | 0 | 0                    | 1    | 0     | 0 | 3     | 24            |
| 10:25 AM                        | 0                       | 0    | 0     | 0 | 0                       | 0    | 0     | 0 | 0                    | 0    | 0     | 0 | 0                    | 0    | 0     | 0 | 0     | 23            |
| 10:30 AM                        | 0                       | 0    | 0     | 0 | 1                       | 0    | 0     | 0 | 0                    | 0    | 0     | 0 | 2                    | 0    | 1     | 0 | 4     | 25            |
| 10:35 AM                        | 0                       | 0    | 1     | 0 | 0                       | 0    | 0     | 0 | 0                    | 0    | 0     | 0 | 0                    | 0    | 0     | 0 | 1     | 24            |
| 10:40 AM                        | 0                       | 0    | 0     | 0 | 0                       | 0    | 0     | 0 | 0                    | 0    | 1     | 0 | 0                    | 0    | 0     | 0 | 1     | 25            |
| 10:45 AM                        | 0                       | 0    | 1     | 0 | 0                       | 0    | 0     | 0 | 0                    | 0    | 1     | 0 | 0                    | 0    | 0     | 0 | 2     | 25            |
| 10:50 AM                        | 0                       | 0    | 2     | 0 | 0                       | 0    | 0     | 0 | 0                    | 0    | 0     | 0 | 0                    | 1    | 1     | 0 | 4     | 27            |
| 10:55 AM                        | 0                       | 0    | 1     | 0 | 0                       | 0    | 1     | 0 | 0                    | 0    | 0     | 0 | 1                    | 0    | 0     | 0 | 3     | 28            |
| 11:00 AM                        | 0                       | 0    | 0     | 0 | 0                       | 0    | 0     | 0 | 0                    | 0    | 0     | 1 | 1                    | 1    | 0     | 0 | 3     | 30            |
| 11:05 AM                        | 0                       | 0    | 0     | 0 | 0                       | 0    | 0     | 0 | 0                    | 0    | 1     | 0 | 0                    | 0    | 0     | 0 | 1     | 26            |
| 11:10 AM                        | 0                       | 0    | 3     | 0 | 0                       | 0    | 0     | 0 | 0                    | 0    | 0     | 0 | 0                    | 0    | 1     | 0 | 4     | 26            |
| 11:15 AM                        | 0                       | 0    | 0     | 0 | 0                       | 0    | 0     | 0 | 0                    | 0    | 1     | 0 | 0                    | 0    | 0     | 0 | 1     | 27            |
| 11:20 AM                        | 0                       | 0    | 1     | 0 | 0                       | 0    | 0     | 0 | 0                    | 0    | 0     | 0 | 0                    | 0    | 0     | 0 | 1     | 25            |
| 11:25 AM                        | 0                       | 0    | 0     | 0 | 0                       | 0    | 0     | 0 | 0                    | 0    | 0     | 0 | 0                    | 0    | 0     | 0 | 0     | 25            |
| 11:30 AM                        | 0                       | 0    | 0     | 0 | 0                       | 0    | 0     | 0 | 0                    | 0    | 0     | 0 | 0                    | 2    | 2     | 0 | 4     | 25            |
| 11:35 AM                        | 0                       | 0    | 0     | 0 | 0                       | 0    | 0     | 0 | 0                    | 0    | 0     | 0 | 0                    | 0    | 1     | 0 | 1     | 25            |
| 11:40 AM                        | 0                       | 0    | 0     | 0 | 1                       | 0    | 0     | 0 | 0                    | 0    | 0     | 0 | 0                    | 0    | 0     | 0 | 1     | 25            |
| 11:45 AM                        | 0                       | 0    | 0     | 0 | 2                       | 0    | 0     | 0 | 0                    | 0    | 0     | 0 | 1                    | 0    | 0     | 0 | 3     | 26            |
| 11:50 AM                        | 0                       | 0    | 0     | 0 | 0                       | 0    | 0     | 0 | 0                    | 0    | 1     | 0 | 0                    | 0    | 0     | 0 | 1     | 23            |
| 11:55 AM                        | 0                       | 0    | 0     | 0 | 0                       | 0    | 0     | 0 | 0                    | 0    | 0     | 0 | 0                    | 0    | 0     | 0 | 0     | 20            |
| 12:00 PM                        | 0                       | 0    | 0     | 0 | 0                       | 0    | 0     | 0 | 0                    | 0    | 0     | 0 | 0                    | 0    | 0     | 0 | 0     | 17            |
| 12:05 PM                        | 0                       | 0    | 1     | 0 | 0                       | 0    | 0     | 0 | 0                    | 0    | 0     | 0 | 0                    | 0    | 0     | 0 | 1     | 17            |
| 12:10 PM                        | 0                       | 0    | 1     | 0 | 0                       | 0    | 0     | 0 | 0                    | 0    | 0     | 0 | 1                    | 2    | 0     | 0 | 4     | 17            |
| 12:15 PM                        | 0                       | 0    | 0     | 0 | 0                       | 0    | 0     | 0 | 0                    | 0    | 0     | 0 | 0                    | 0    | 0     | 0 | 0     | 16            |
| 12:20 PM                        | 0                       | 0    | 1     | 0 | 1                       | 0    | 0     | 0 | 0                    | 0    | 0     | 0 | 1                    | 0    | 2     | 0 | 5     | 20            |
| 12:25 PM                        | 0                       | 0    | 0     | 0 | 0                       | 0    | 0     | 0 | 0                    | 0    | 0     | 0 | 0                    | 0    | 0     | 0 | 0     | 20            |
| 12:30 PM                        | 0                       | 0    | 0     | 0 | 0                       | 0    | 0     | 0 | 0                    | 0    | 0     | 0 | 0                    | 0    | 0     | 0 | 0     | 16            |
| 12:35 PM                        | 0                       | 0    | 0     | 0 | 0                       | 0    | 0     | 0 | 0                    | 0    | 0     | 0 | 1                    | 0    | 0     | 0 | 1     | 16            |
| 12:40 PM                        | 0                       | 1    | 1     | 0 | 0                       | 0    | 0     | 0 | 0                    | 0    | 1     | 0 | 2                    | 0    | 0     | 0 | 5     | 20            |
| 12:45 PM                        | 0                       | 0    | 0     | 0 | 2                       | 0    | 0     | 0 | 0                    | 0    | 1     | 0 | 0                    | 0    | 0     | 0 | 3     | 20            |
| 12:50 PM                        | 0                       | 0    | 0     | 0 | 0                       | 0    | 0     | 0 | 0                    | 0    | 0     | 0 | 1                    | 0    | 2     | 0 | 3     | 22            |
| 12:55 PM                        | 0                       | 0    | 0     | 0 | 0                       | 0    | 0     | 0 | 0                    | 0    | 0     | 0 | 0                    | 0    | 1     | 0 | 1     | 23            |
| 1:00 PM                         | 0                       | 0    | 0     | 0 | 1                       | 0    | 0     | 0 | 0                    | 0    | 0     | 0 | 0                    | 0    | 0     | 0 | 1     | 24            |
| 1:05 PM                         | 0                       | 0    | 1     | 0 | 1                       | 0    | 0     | 0 | 0                    | 0    | 0     | 0 | 0                    | 0    | 0     | 0 | 2     | 25            |
| 1:10 PM                         | 0                       | 0    | 0     | 0 | 0                       | 0    | 0     | 0 | 0                    | 0    | 0     | 0 | 0                    | 0    | 1     | 0 | 1     | 22            |
| 1:15 PM                         | 0                       | 0    | 1     | 0 | 1                       | 0    | 0     | 0 | 0                    | 0    | 0     | 0 | 1                    | 0    | 1     | 0 | 4     | 26            |
| 1:20 PM                         | 0                       | 0    | 0     | 0 | 1                       | 0    | 0     | 0 | 0                    | 0    | 0     | 0 | 0                    | 0    | 0     | 0 | 1     | 22            |
| 1:25 PM                         | 0                       | 0    | 0     | 0 | 0                       | 0    | 0     | 0 | 0                    | 0    | 0     | 0 | 1                    | 0    | 0     | 0 | 1     | 23            |
| 1:30 PM                         | 0                       | 0    | 0     | 0 | 0                       | 0    | 0     | 0 | 0                    | 0    | 0     | 0 | 0                    | 0    | 1     | 0 | 1     | 24            |
| 1:35 PM                         | 0                       | 0    | 0     | 0 | 0                       | 0    | 0     | 0 | 0                    | 0    | 0     | 0 | 0                    | 0    | 0     | 0 | 0     | 23            |
| 1:40 PM                         | 0                       | 0    | 0     | 0 | 0                       | 0    | 0     | 0 | 0                    | 0    | 0     | 0 | 0                    | 1    | 2     | 0 | 3     | 21            |
| 1:45 PM                         | 0                       | 0    | 1     | 0 | 2                       | 0    | 0     | 0 | 0                    | 0    | 0     | 0 | 1                    | 0    | 0     | 0 | 4     | 22            |
| 1:50 PM                         | 0                       | 0    | 2     | 0 | 0                       | 0    | 0     | 0 | 0                    | 0    | 1     | 0 | 2                    | 0    | 0     | 0 | 5     | 24            |
| 1:55 PM                         | 0                       | 0    | 0     | 0 | 0                       | 0    | 0     | 0 | 0                    | 0    | 0     | 0 | 0                    | 0    | 0     | 0 | 0     | 23            |
| 2:00 PM                         | 0                       | 0    | 0     | 0 | 0                       | 0    | 0     | 0 | 0                    | 0    | 0     | 0 | 0                    | 0    | 0     | 0 | 0     | 22            |
| 2:05 PM                         | 0                       | 0    | 0     | 0 | 1                       | 0    | 0     | 0 | 0                    | 0    | 0     | 0 | 1                    | 0    | 0     | 0 | 2     | 22            |
| 2:10 PM                         | 0                       | 0    | 0     | 0 | 0                       | 0    | 0     | 0 | 0                    | 0    | 0     | 0 | 0                    | 1    | 0     | 0 | 1     | 22            |
| 2:15 PM                         | 0                       | 0    | 0     | 0 | 1                       | 0    | 0     | 0 | 0                    | 0    | 0     | 0 | 0                    | 1    | 1     | 0 | 3     | 21            |
| 2:20 PM                         | 0                       | 0    | 0     | 0 | 0                       | 0    | 1     | 0 | 0                    | 0    | 1     | 0 | 1                    | 0    | 1     | 0 | 4     | 24            |
| 2:25 PM                         | 0                       | 0    | 0     | 0 | 1                       | 0    | 0     | 0 | 0                    | 0    | 0     | 0 | 0                    | 0    | 0     | 0 | 1     | 24            |
| 2:30 PM                         | 0                       | 0    | 3     | 0 | 1                       | 0    | 0     | 0 | 0                    | 0    | 0     | 0 | 1                    | 0    | 1     | 0 | 6     | 29            |
| 2:35 PM                         | 0                       | 0    | 1     | 0 | 0                       | 0    | 0     | 0 | 0                    | 0    | 0     | 0 | 1                    | 0    | 0     | 0 | 2     | 31            |
| 2:40 PM                         | 0                       | 0    | 0     | 0 | 0                       | 0    | 0     | 0 | 0                    | 0    | 0     | 0 | 0                    | 0    | 0     | 0 | 0     | 28            |
| 2:45 PM                         | 0                       | 0    | 2     | 0 | 0                       | 0    | 0     | 0 | 0                    | 0    | 0     | 0 | 0                    | 0    | 0     | 0 | 2     | 26            |
| 2:50 PM                         | 0                       | 0    | 0     | 0 | 0                       | 0    | 0     | 0 | 0                    | 0    | 0     | 0 | 0                    | 0    | 0     | 0 | 0     | 21            |
| 2:55 PM                         | 0                       | 0    | 1     | 0 | 0                       | 0    | 0     | 0 | 0                    | 0    | 1     | 0 | 0                    | 0    | 1     | 0 | 3     | 24            |
| 3:00 PM                         | 0                       | 0    | 0     | 0 | 0                       | 0    | 0     | 0 | 0                    | 0    | 0     | 0 | 0                    | 0    | 1     | 0 | 1     | 25            |
| 3:05 PM                         | 0                       | 0    | 0     | 0 | 0                       | 0    | 0     | 0 | 0                    | 0    | 0     | 0 | 0                    | 0    | 0     | 0 | 0     | 23            |
| 3:10 PM                         | 0                       | 0    | 0     | 0 | 0                       | 0    | 0     | 0 | 0                    | 0    | 0     | 0 | 1                    | 0    | 0     | 0 | 1     | 23            |
| 3:15 PM                         | 0                       | 0    | 0     | 0 | 0                       | 0    | 0     | 0 | 0                    | 0    | 0     | 0 | 0                    | 1    | 0     | 0 | 1     | 21            |
| 3:20 PM                         | 0                       | 0    | 0     | 0 | 0                       | 0    | 0     | 0 | 0                    | 0    | 0     | 0 | 0                    | 0    | 0     | 0 | 0     | 17            |
| 3:25 PM                         | 0                       | 0    | 1     | 0 | 1                       | 0    | 0     | 0 | 0                    | 0    | 0     | 0 | 1                    | 0    | 2     | 0 | 5     | 21            |
| 3:30 PM                         | 0                       | 0    | 0     | 0 | 0                       | 0    | 0     | 0 | 0                    | 0    | 1     | 0 | 0                    | 0    | 0     | 0 | 1     | 16            |
| 3:35 PM                         | 0                       | 0    | 0     | 0 | 1                       | 0    | 0     | 0 | 0                    | 0    | 0     | 0 | 1                    | 0    | 1     | 0 | 3     | 17            |
| 3:40 PM                         | 0                       | 0    | 0     | 0 | 1                       | 0    | 0     | 0 | 0                    | 0    | 0     | 0 | 1                    | 0    | 0     | 0 | 2     | 19            |
| 3:45 PM                         | 0                       | 0    | 0     | 0 | 1                       | 0    | 0     | 0 | 0                    | 0    | 0     | 0 | 1                    | 0    | 1     | 0 | 3     | 20            |
| 3:50 PM                         | 0                       | 0    | 0     | 0 | 0                       | 0    | 0     | 0 | 0                    | 0    | 0     | 0 | 0                    | 0    | 0     | 0 | 0     | 20            |
| 3:55 PM                         | 0                       | 0    | 0     | 0 | 0                       | 0    | 0     | 0 | 0                    | 0    | 0     | 0 | 0                    | 0    | 0     | 0 | 0     | 17            |
| 4:00 PM                         | 0                       | 0    | 0     | 0 | 0                       | 0    | 0     | 0 | 0                    | 0    | 0     | 0 | 0                    | 0    | 0     | 0 | 0     | 16            |
| 4:05 PM                         | 0                       | 0    | 0     | 0 | 1                       | 0    | 0     | 0 | 0                    | 0    | 0     | 0 | 0                    | 0    | 1     | 0 | 2     | 18            |
| 4:10 PM                         | 0                       | 0    | 0     | 0 | 0                       | 0    | 0     | 0 | 0                    | 0    | 1     | 0 | 0                    | 0    | 0     | 0 | 2     | 19            |
| 4:15 PM                         | 0                       | 0    | 1     | 0 | 2                       | 0    | 0     | 0 | 0                    | 0    | 0     | 0 | 0                    | 0    | 1     | 0 | 4     | 22            |
| 4:20 PM                         | 0                       | 0    | 0     | 0 | 0                       | 0    | 0     | 0 | 0                    | 0    | 0     | 0 | 0                    | 0    | 0     | 0 | 0     | 22            |
| 4:25 PM                         | 0                       | 0    | 0     | 0 | 0                       | 0    | 0     | 0 | 0                    | 0    | 0     | 0 | 1                    | 0    | 0     | 0 | 1     | 18            |

**Attachment B**

| 5-Min Count Period Beginning At | Rebecca Ln (Northbound) |      |       |   | Rebecca Ln (Southbound) |      |       |   | Gwen Ave (Eastbound) |      |       |   | Gwen Ave (Westbound) |      |       |   | Total | Hourly Totals |
|---------------------------------|-------------------------|------|-------|---|-------------------------|------|-------|---|----------------------|------|-------|---|----------------------|------|-------|---|-------|---------------|
|                                 | Left                    | Thru | Right | U | Left                    | Thru | Right | U | Left                 | Thru | Right | U | Left                 | Thru | Right | U |       |               |
| 4:30 PM                         | 0                       | 0    | 1     | 0 | 0                       | 0    | 0     | 0 | 0                    | 0    | 0     | 0 | 0                    | 0    | 0     | 0 | 1     | 18            |
| 4:35 PM                         | 0                       | 0    | 0     | 0 | 0                       | 0    | 0     | 0 | 0                    | 0    | 0     | 0 | 1                    | 1    | 1     | 0 | 3     | 18            |
| 4:40 PM                         | 0                       | 0    | 0     | 0 | 0                       | 0    | 0     | 0 | 0                    | 0    | 0     | 0 | 0                    | 0    | 2     | 0 | 2     | 18            |
| 4:45 PM                         | 0                       | 0    | 0     | 0 | 0                       | 0    | 0     | 0 | 0                    | 0    | 0     | 0 | 0                    | 0    | 0     | 0 | 0     | 15            |
| 4:50 PM                         | 0                       | 0    | 0     | 0 | 0                       | 0    | 0     | 0 | 0                    | 1    | 0     | 0 | 1                    | 0    | 0     | 0 | 2     | 17            |
| 4:55 PM                         | 0                       | 0    | 0     | 0 | 0                       | 0    | 0     | 0 | 0                    | 0    | 0     | 0 | 0                    | 0    | 0     | 0 | 0     | 17            |
| 5:00 PM                         | 0                       | 0    | 0     | 0 | 0                       | 0    | 0     | 0 | 0                    | 0    | 0     | 0 | 1                    | 0    | 0     | 0 | 1     | 18            |
| 5:05 PM                         | 0                       | 0    | 0     | 0 | 0                       | 0    | 0     | 0 | 0                    | 0    | 0     | 0 | 3                    | 0    | 0     | 0 | 3     | 19            |
| 5:10 PM                         | 0                       | 0    | 1     | 0 | 0                       | 0    | 0     | 0 | 0                    | 0    | 0     | 0 | 0                    | 1    | 1     | 0 | 3     | 20            |
| 5:15 PM                         | 0                       | 0    | 1     | 0 | 0                       | 1    | 0     | 0 | 0                    | 0    | 0     | 0 | 0                    | 0    | 0     | 0 | 2     | 18            |
| 5:20 PM                         | 0                       | 0    | 0     | 0 | 0                       | 0    | 0     | 0 | 0                    | 0    | 0     | 0 | 0                    | 0    | 0     | 0 | 0     | 18            |
| 5:25 PM                         | 0                       | 0    | 1     | 0 | 0                       | 0    | 0     | 0 | 0                    | 0    | 0     | 0 | 0                    | 0    | 0     | 0 | 1     | 18            |
| 5:30 PM                         | 0                       | 0    | 1     | 0 | 0                       | 0    | 0     | 0 | 0                    | 0    | 0     | 0 | 0                    | 0    | 0     | 0 | 1     | 18            |
| 5:35 PM                         | 0                       | 0    | 0     | 0 | 0                       | 0    | 0     | 0 | 0                    | 0    | 0     | 0 | 1                    | 0    | 0     | 0 | 1     | 16            |
| 5:40 PM                         | 0                       | 0    | 1     | 0 | 0                       | 0    | 0     | 0 | 0                    | 0    | 0     | 0 | 1                    | 1    | 1     | 0 | 4     | 18            |
| 5:45 PM                         | 0                       | 0    | 1     | 0 | 2                       | 0    | 0     | 0 | 0                    | 0    | 0     | 0 | 0                    | 0    | 1     | 0 | 4     | 22            |
| 5:50 PM                         | 0                       | 0    | 0     | 0 | 0                       | 0    | 0     | 0 | 0                    | 0    | 0     | 0 | 0                    | 0    | 0     | 0 | 0     | 20            |
| 5:55 PM                         | 0                       | 0    | 0     | 0 | 0                       | 0    | 0     | 0 | 0                    | 0    | 0     | 0 | 0                    | 0    | 1     | 0 | 1     | 21            |
| 6:00 PM                         | 0                       | 0    | 0     | 0 | 0                       | 0    | 0     | 0 | 0                    | 0    | 0     | 0 | 0                    | 0    | 0     | 0 | 0     | 20            |
| 6:05 PM                         | 0                       | 0    | 1     | 0 | 0                       | 0    | 0     | 0 | 0                    | 0    | 0     | 0 | 0                    | 0    | 2     | 0 | 3     | 20            |
| 6:10 PM                         | 0                       | 0    | 0     | 0 | 0                       | 0    | 0     | 0 | 0                    | 0    | 0     | 0 | 0                    | 0    | 0     | 0 | 0     | 17            |
| 6:15 PM                         | 0                       | 0    | 1     | 0 | 0                       | 0    | 0     | 0 | 0                    | 0    | 0     | 0 | 0                    | 0    | 0     | 0 | 1     | 16            |
| 6:20 PM                         | 0                       | 0    | 1     | 0 | 0                       | 0    | 0     | 0 | 0                    | 0    | 0     | 0 | 0                    | 0    | 0     | 0 | 1     | 17            |
| 6:25 PM                         | 0                       | 0    | 0     | 0 | 0                       | 0    | 0     | 0 | 0                    | 0    | 0     | 0 | 1                    | 0    | 1     | 0 | 2     | 18            |
| 6:30 PM                         | 0                       | 0    | 0     | 0 | 0                       | 0    | 0     | 0 | 0                    | 0    | 0     | 0 | 1                    | 0    | 0     | 0 | 1     | 18            |
| 6:35 PM                         | 0                       | 0    | 0     | 0 | 0                       | 0    | 0     | 0 | 0                    | 0    | 0     | 0 | 1                    | 0    | 0     | 0 | 1     | 18            |
| 6:40 PM                         | 0                       | 0    | 0     | 0 | 0                       | 0    | 0     | 0 | 0                    | 0    | 0     | 0 | 0                    | 0    | 0     | 0 | 0     | 14            |
| 6:45 PM                         | 0                       | 0    | 0     | 0 | 0                       | 0    | 0     | 0 | 0                    | 0    | 0     | 0 | 2                    | 0    | 0     | 0 | 2     | 12            |
| 6:50 PM                         | 0                       | 0    | 0     | 0 | 0                       | 0    | 0     | 0 | 0                    | 0    | 0     | 0 | 1                    | 0    | 0     | 0 | 1     | 13            |
| 6:55 PM                         | 0                       | 0    | 1     | 0 | 0                       | 0    | 0     | 0 | 0                    | 0    | 0     | 0 | 1                    | 0    | 0     | 0 | 2     | 14            |
| 7:00 PM                         | 0                       | 0    | 0     | 0 | 0                       | 0    | 0     | 0 | 0                    | 0    | 0     | 0 | 1                    | 0    | 0     | 0 | 1     | 15            |
| 7:05 PM                         | 0                       | 0    | 0     | 0 | 0                       | 0    | 0     | 0 | 0                    | 0    | 0     | 0 | 0                    | 0    | 0     | 0 | 0     | 12            |
| 7:10 PM                         | 0                       | 0    | 0     | 0 | 0                       | 0    | 0     | 0 | 0                    | 0    | 0     | 0 | 0                    | 0    | 0     | 0 | 0     | 12            |
| 7:15 PM                         | 0                       | 0    | 0     | 0 | 0                       | 0    | 0     | 0 | 0                    | 0    | 0     | 0 | 1                    | 0    | 0     | 0 | 1     | 12            |
| 7:20 PM                         | 0                       | 0    | 2     | 0 | 0                       | 0    | 0     | 0 | 0                    | 0    | 0     | 0 | 1                    | 0    | 0     | 0 | 3     | 14            |
| 7:25 PM                         | 0                       | 0    | 0     | 0 | 0                       | 0    | 0     | 0 | 0                    | 0    | 0     | 0 | 0                    | 0    | 0     | 0 | 0     | 12            |
| 7:30 PM                         | 0                       | 0    | 0     | 0 | 0                       | 0    | 0     | 0 | 0                    | 0    | 0     | 0 | 0                    | 0    | 0     | 0 | 0     | 11            |
| 7:35 PM                         | 0                       | 0    | 0     | 0 | 0                       | 0    | 0     | 0 | 0                    | 0    | 0     | 0 | 0                    | 0    | 1     | 0 | 1     | 11            |
| 7:40 PM                         | 0                       | 0    | 0     | 0 | 0                       | 1    | 0     | 0 | 0                    | 0    | 0     | 0 | 0                    | 0    | 0     | 0 | 1     | 12            |
| 7:45 PM                         | 0                       | 0    | 1     | 0 | 0                       | 0    | 0     | 0 | 0                    | 0    | 0     | 0 | 0                    | 0    | 0     | 0 | 1     | 11            |
| 7:50 PM                         | 0                       | 0    | 0     | 0 | 0                       | 0    | 0     | 0 | 0                    | 0    | 0     | 0 | 0                    | 0    | 0     | 0 | 0     | 10            |
| 7:55 PM                         | 0                       | 0    | 0     | 0 | 0                       | 0    | 0     | 0 | 0                    | 0    | 0     | 0 | 0                    | 0    | 0     | 0 | 0     | 8             |
| 8:00 PM                         | 0                       | 0    | 1     | 0 | 1                       | 0    | 0     | 0 | 0                    | 0    | 0     | 0 | 1                    | 0    | 0     | 0 | 3     | 10            |
| 8:05 PM                         | 0                       | 0    | 0     | 0 | 0                       | 0    | 0     | 0 | 0                    | 0    | 0     | 0 | 0                    | 0    | 0     | 0 | 0     | 10            |
| 8:10 PM                         | 0                       | 0    | 0     | 0 | 0                       | 0    | 0     | 0 | 0                    | 0    | 0     | 0 | 0                    | 0    | 0     | 0 | 0     | 10            |
| 8:15 PM                         | 0                       | 0    | 0     | 0 | 0                       | 0    | 0     | 0 | 0                    | 0    | 0     | 0 | 0                    | 0    | 1     | 0 | 1     | 10            |
| 8:20 PM                         | 0                       | 0    | 0     | 0 | 0                       | 0    | 0     | 0 | 0                    | 0    | 0     | 0 | 1                    | 0    | 0     | 0 | 1     | 8             |
| 8:25 PM                         | 0                       | 0    | 0     | 0 | 0                       | 0    | 0     | 0 | 0                    | 0    | 0     | 0 | 0                    | 0    | 0     | 0 | 0     | 8             |
| 8:30 PM                         | 0                       | 0    | 0     | 0 | 0                       | 0    | 0     | 0 | 0                    | 0    | 0     | 0 | 1                    | 1    | 0     | 0 | 2     | 10            |
| 8:35 PM                         | 0                       | 0    | 0     | 0 | 0                       | 0    | 0     | 0 | 0                    | 1    | 0     | 0 | 0                    | 0    | 0     | 0 | 1     | 10            |
| 8:40 PM                         | 0                       | 0    | 0     | 0 | 0                       | 0    | 0     | 0 | 0                    | 0    | 0     | 0 | 0                    | 0    | 0     | 0 | 0     | 9             |
| 8:45 PM                         | 0                       | 0    | 0     | 0 | 0                       | 0    | 0     | 0 | 0                    | 0    | 0     | 0 | 0                    | 0    | 2     | 0 | 2     | 10            |
| 8:50 PM                         | 0                       | 0    | 0     | 0 | 0                       | 0    | 0     | 0 | 0                    | 0    | 0     | 0 | 0                    | 0    | 0     | 0 | 0     | 10            |
| 8:55 PM                         | 0                       | 0    | 0     | 0 | 0                       | 0    | 0     | 0 | 0                    | 0    | 0     | 0 | 0                    | 0    | 0     | 0 | 0     | 10            |
| 9:00 PM                         | 0                       | 0    | 0     | 0 | 0                       | 0    | 0     | 0 | 0                    | 0    | 0     | 0 | 0                    | 0    | 0     | 0 | 0     | 7             |
| 9:05 PM                         | 0                       | 0    | 0     | 0 | 0                       | 0    | 0     | 0 | 0                    | 0    | 0     | 0 | 0                    | 0    | 0     | 0 | 0     | 7             |
| 9:10 PM                         | 0                       | 0    | 0     | 0 | 0                       | 0    | 0     | 0 | 0                    | 0    | 0     | 0 | 0                    | 0    | 0     | 0 | 0     | 7             |
| 9:15 PM                         | 0                       | 0    | 0     | 0 | 0                       | 0    | 0     | 0 | 0                    | 0    | 0     | 0 | 0                    | 0    | 0     | 0 | 0     | 6             |
| 9:20 PM                         | 0                       | 0    | 0     | 0 | 1                       | 0    | 0     | 0 | 0                    | 0    | 0     | 0 | 0                    | 0    | 1     | 0 | 2     | 7             |
| 9:25 PM                         | 0                       | 0    | 0     | 0 | 0                       | 0    | 0     | 0 | 0                    | 0    | 0     | 0 | 0                    | 0    | 0     | 0 | 0     | 7             |
| 9:30 PM                         | 0                       | 0    | 0     | 0 | 0                       | 0    | 0     | 0 | 0                    | 0    | 0     | 0 | 0                    | 1    | 0     | 0 | 1     | 6             |
| 9:35 PM                         | 0                       | 0    | 0     | 0 | 0                       | 0    | 0     | 0 | 0                    | 0    | 0     | 0 | 0                    | 0    | 0     | 0 | 0     | 5             |
| 9:40 PM                         | 0                       | 0    | 0     | 0 | 0                       | 0    | 0     | 0 | 0                    | 0    | 0     | 0 | 0                    | 0    | 0     | 0 | 0     | 5             |
| 9:45 PM                         | 0                       | 0    | 0     | 0 | 0                       | 0    | 0     | 0 | 0                    | 0    | 0     | 0 | 0                    | 0    | 0     | 0 | 0     | 3             |
| 9:50 PM                         | 0                       | 0    | 0     | 0 | 0                       | 0    | 0     | 0 | 0                    | 0    | 0     | 0 | 0                    | 0    | 0     | 0 | 0     | 3             |
| 9:55 PM                         | 0                       | 0    | 0     | 0 | 0                       | 0    | 0     | 0 | 0                    | 0    | 0     | 0 | 0                    | 0    | 0     | 0 | 0     | 3             |
| Peak 15-Min Flowrates           | Northbound              |      |       |   | Southbound              |      |       |   | Eastbound            |      |       |   | Westbound            |      |       |   | Total |               |
|                                 | Left                    | Thru | Right | U | Left                    | Thru | Right | U | Left                 | Thru | Right | U | Left                 | Thru | Right | U |       |               |
| All Vehicles                    | 0                       | 0    | 12    | 0 | 8                       | 0    | 0     | 0 | 0                    | 4    | 0     | 0 | 12                   | 4    | 8     | 0 | 48    |               |
| Heavy Trucks                    | 0                       | 0    | 0     |   | 0                       | 0    | 0     |   | 0                    | 0    | 0     |   | 0                    | 0    | 0     |   | 0     |               |
| Buses                           |                         |      |       |   |                         |      |       |   |                      |      |       |   |                      |      |       |   |       |               |
| Pedestrians                     |                         | 0    |       |   |                         | 0    |       |   |                      | 0    |       |   |                      | 0    |       |   | 0     |               |
| Bicycles                        | 0                       | 0    | 0     |   | 0                       | 0    | 0     |   | 0                    | 0    | 0     |   | 0                    | 0    | 0     |   | 0     |               |
| Scoters                         |                         |      |       |   |                         |      |       |   |                      |      |       |   |                      |      |       |   |       |               |
| <i>Comments:</i>                |                         |      |       |   |                         |      |       |   |                      |      |       |   |                      |      |       |   |       |               |

LOCATION: Howland Way -- Arbolada Way  
 CITY/STATE: North Tustin, CA

QC JOB #: 16966443  
 DATE: Thu, Apr 10 2025

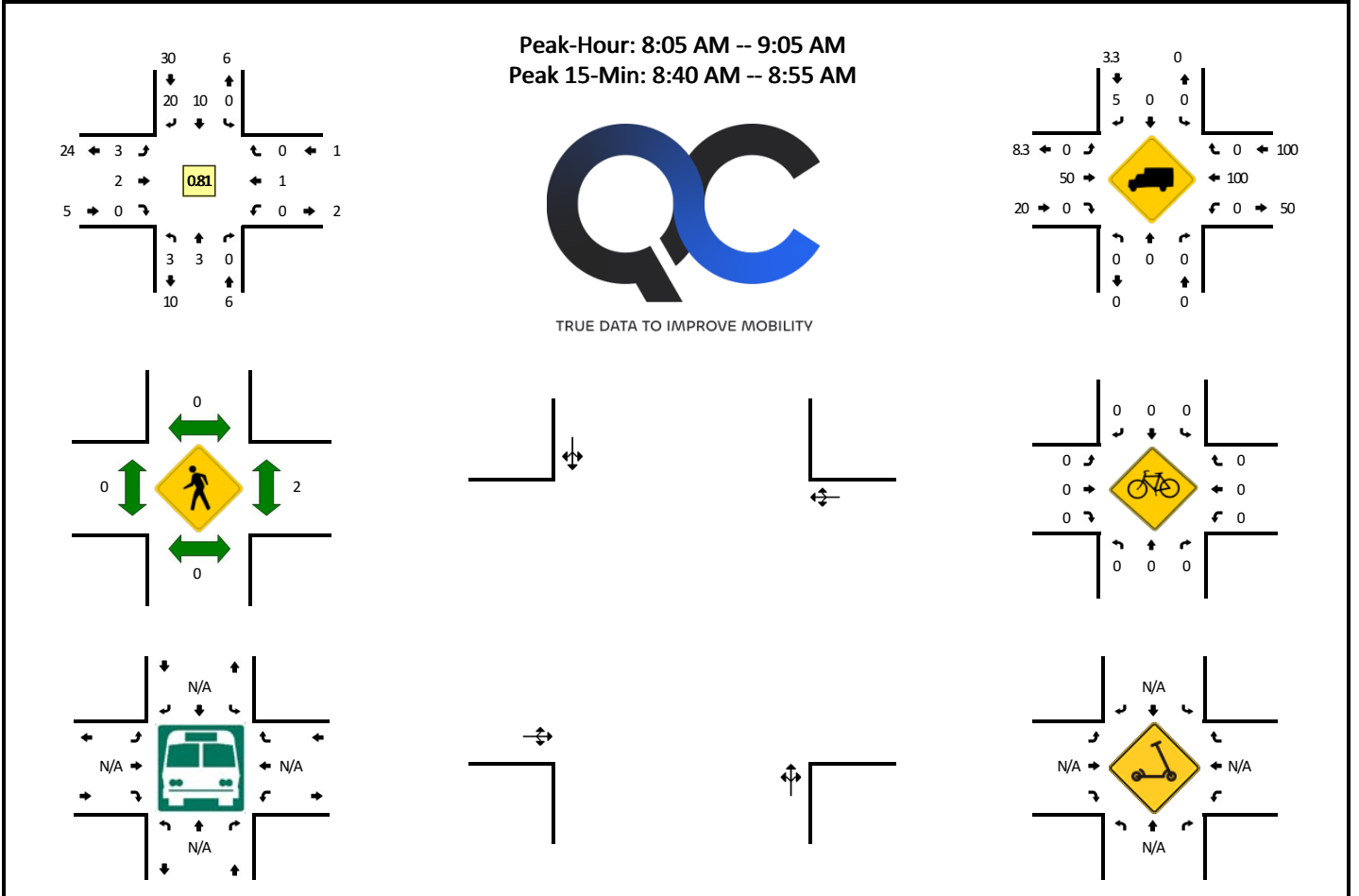

| 5-Min Count Period Beginning At | Howland Way (Northbound) |      |       |   | Howland Way (Southbound) |      |       |   | Arbolada Way (Eastbound) |      |       |   | Arbolada Way (Westbound) |      |       |   | Total | Hourly Totals |
|---------------------------------|--------------------------|------|-------|---|--------------------------|------|-------|---|--------------------------|------|-------|---|--------------------------|------|-------|---|-------|---------------|
|                                 | Left                     | Thru | Right | U | Left                     | Thru | Right | U | Left                     | Thru | Right | U | Left                     | Thru | Right | U |       |               |
| 6:00 AM                         | 0                        | 0    | 0     | 0 | 0                        | 0    | 0     | 0 | 0                        | 0    | 0     | 0 | 0                        | 0    | 0     | 0 | 0     | 0             |
| 6:05 AM                         | 0                        | 0    | 0     | 0 | 0                        | 0    | 0     | 0 | 0                        | 0    | 0     | 0 | 0                        | 0    | 0     | 0 | 0     | 0             |
| 6:10 AM                         | 0                        | 0    | 0     | 0 | 0                        | 0    | 0     | 0 | 0                        | 0    | 0     | 0 | 0                        | 0    | 0     | 0 | 0     | 0             |
| 6:15 AM                         | 0                        | 0    | 0     | 0 | 0                        | 1    | 0     | 0 | 0                        | 0    | 0     | 0 | 0                        | 0    | 0     | 0 | 0     | 1             |
| 6:20 AM                         | 0                        | 0    | 0     | 0 | 0                        | 0    | 0     | 0 | 0                        | 1    | 0     | 0 | 0                        | 0    | 0     | 0 | 0     | 1             |
| 6:25 AM                         | 0                        | 0    | 0     | 0 | 0                        | 0    | 0     | 0 | 0                        | 0    | 0     | 0 | 0                        | 0    | 0     | 0 | 0     | 0             |
| 6:30 AM                         | 0                        | 0    | 0     | 0 | 0                        | 0    | 0     | 0 | 0                        | 0    | 0     | 0 | 0                        | 0    | 0     | 0 | 0     | 0             |
| 6:35 AM                         | 0                        | 0    | 0     | 0 | 0                        | 0    | 0     | 0 | 0                        | 0    | 0     | 0 | 0                        | 0    | 0     | 0 | 0     | 0             |
| 6:40 AM                         | 0                        | 0    | 0     | 0 | 0                        | 0    | 0     | 0 | 0                        | 0    | 0     | 0 | 0                        | 0    | 0     | 0 | 0     | 0             |
| 6:45 AM                         | 0                        | 0    | 0     | 0 | 0                        | 0    | 0     | 0 | 0                        | 0    | 0     | 0 | 0                        | 0    | 0     | 0 | 0     | 0             |
| 6:50 AM                         | 0                        | 0    | 0     | 0 | 0                        | 0    | 0     | 0 | 0                        | 0    | 0     | 0 | 0                        | 0    | 0     | 0 | 0     | 0             |
| 6:55 AM                         | 0                        | 0    | 0     | 0 | 0                        | 0    | 0     | 0 | 0                        | 0    | 0     | 0 | 0                        | 1    | 0     | 0 | 0     | 1             |
| 7:00 AM                         | 1                        | 1    | 0     | 0 | 0                        | 0    | 0     | 0 | 0                        | 0    | 0     | 0 | 0                        | 0    | 0     | 0 | 0     | 2             |
| 7:05 AM                         | 0                        | 0    | 0     | 0 | 0                        | 0    | 0     | 0 | 0                        | 1    | 0     | 0 | 0                        | 0    | 0     | 0 | 0     | 1             |
| 7:10 AM                         | 0                        | 1    | 0     | 0 | 0                        | 0    | 0     | 0 | 0                        | 0    | 0     | 0 | 0                        | 0    | 0     | 0 | 0     | 1             |
| 7:15 AM                         | 0                        | 1    | 0     | 0 | 0                        | 0    | 0     | 0 | 0                        | 0    | 0     | 0 | 0                        | 0    | 0     | 0 | 0     | 1             |
| 7:20 AM                         | 0                        | 0    | 0     | 0 | 0                        | 0    | 1     | 0 | 0                        | 0    | 0     | 1 | 0                        | 0    | 0     | 0 | 0     | 2             |
| 7:25 AM                         | 0                        | 0    | 0     | 0 | 0                        | 0    | 0     | 0 | 0                        | 0    | 0     | 0 | 0                        | 0    | 0     | 0 | 0     | 0             |
| 7:30 AM                         | 0                        | 0    | 0     | 0 | 0                        | 1    | 0     | 0 | 0                        | 0    | 0     | 0 | 0                        | 0    | 0     | 0 | 0     | 1             |
| 7:35 AM                         | 1                        | 0    | 0     | 0 | 0                        | 0    | 2     | 0 | 0                        | 0    | 0     | 0 | 0                        | 0    | 0     | 0 | 0     | 3             |
| 7:40 AM                         | 0                        | 0    | 0     | 0 | 0                        | 0    | 1     | 0 | 1                        | 0    | 0     | 0 | 0                        | 0    | 0     | 0 | 0     | 2             |
| 7:45 AM                         | 0                        | 1    | 0     | 0 | 0                        | 0    | 1     | 0 | 0                        | 0    | 0     | 0 | 0                        | 0    | 0     | 0 | 0     | 2             |
| 7:50 AM                         | 0                        | 1    | 0     | 0 | 0                        | 1    | 1     | 0 | 0                        | 0    | 0     | 0 | 0                        | 0    | 0     | 0 | 0     | 3             |
| 7:55 AM                         | 0                        | 4    | 0     | 0 | 0                        | 0    | 0     | 0 | 0                        | 0    | 0     | 0 | 0                        | 0    | 0     | 0 | 0     | 4             |
| 8:00 AM                         | 0                        | 0    | 0     | 0 | 0                        | 0    | 0     | 0 | 0                        | 0    | 0     | 0 | 0                        | 0    | 0     | 0 | 0     | 0             |
| 8:05 AM                         | 0                        | 1    | 0     | 0 | 0                        | 4    | 2     | 0 | 0                        | 0    | 0     | 0 | 0                        | 0    | 0     | 0 | 0     | 7             |
| 8:10 AM                         | 0                        | 0    | 0     | 0 | 0                        | 0    | 1     | 0 | 0                        | 0    | 0     | 0 | 0                        | 0    | 0     | 0 | 0     | 1             |
| 8:15 AM                         | 0                        | 0    | 0     | 0 | 0                        | 2    | 1     | 0 | 0                        | 0    | 0     | 0 | 0                        | 0    | 0     | 0 | 0     | 3             |
| 8:20 AM                         | 0                        | 0    | 0     | 0 | 0                        | 1    | 3     | 0 | 0                        | 0    | 0     | 0 | 0                        | 0    | 0     | 0 | 0     | 4             |
| 8:25 AM                         | 1                        | 1    | 0     | 0 | 0                        | 1    | 2     | 0 | 0                        | 0    | 0     | 0 | 0                        | 0    | 0     | 0 | 0     | 5             |
| 8:30 AM                         | 0                        | 0    | 0     | 0 | 0                        | 0    | 3     | 0 | 0                        | 0    | 0     | 0 | 0                        | 0    | 0     | 0 | 0     | 3             |
| 8:35 AM                         | 1                        | 0    | 0     | 0 | 0                        | 0    | 0     | 0 | 0                        | 0    | 0     | 0 | 0                        | 0    | 0     | 0 | 0     | 1             |
| 8:40 AM                         | 0                        | 0    | 0     | 0 | 0                        | 0    | 1     | 0 | 1                        | 1    | 0     | 0 | 0                        | 1    | 0     | 0 | 0     | 4             |
| 8:45 AM                         | 0                        | 0    | 0     | 0 | 0                        | 1    | 2     | 0 | 1                        | 1    | 0     | 0 | 0                        | 0    | 0     | 0 | 0     | 5             |
| 8:50 AM                         | 1                        | 1    | 0     | 0 | 0                        | 0    | 2     | 0 | 0                        | 0    | 0     | 0 | 0                        | 0    | 0     | 0 | 0     | 4             |
| 8:55 AM                         | 0                        | 0    | 0     | 0 | 0                        | 1    | 1     | 0 | 0                        | 0    | 0     | 0 | 0                        | 0    | 0     | 0 | 0     | 2             |
| 9:00 AM                         | 0                        | 0    | 0     | 0 | 0                        | 0    | 2     | 0 | 1                        | 0    | 0     | 0 | 0                        | 0    | 0     | 0 | 0     | 3             |
| 9:05 AM                         | 0                        | 0    | 0     | 0 | 0                        | 0    | 0     | 0 | 0                        | 0    | 1     | 0 | 0                        | 0    | 0     | 0 | 0     | 1             |

**Attachment B**

| 5-Min Count Period Beginning At | Howland Way (Northbound) |      |       |   | Howland Way (Southbound) |      |       |   | Arbolada Way (Eastbound) |      |       |   | Arbolada Way (Westbound) |      |       |   | Total | Hourly Totals |
|---------------------------------|--------------------------|------|-------|---|--------------------------|------|-------|---|--------------------------|------|-------|---|--------------------------|------|-------|---|-------|---------------|
|                                 | Left                     | Thru | Right | U | Left                     | Thru | Right | U | Left                     | Thru | Right | U | Left                     | Thru | Right | U |       |               |
| 9:10 AM                         | 0                        | 0    | 0     | 0 | 0                        | 0    | 4     | 0 | 0                        | 0    | 0     | 0 | 0                        | 0    | 0     | 0 | 4     | 39            |
| 9:15 AM                         | 1                        | 0    | 0     | 0 | 0                        | 0    | 0     | 0 | 2                        | 0    | 0     | 0 | 0                        | 0    | 0     | 0 | 3     | 39            |
| 9:20 AM                         | 0                        | 0    | 0     | 0 | 0                        | 0    | 1     | 0 | 0                        | 0    | 0     | 0 | 0                        | 0    | 0     | 0 | 1     | 36            |
| 9:25 AM                         | 1                        | 0    | 0     | 0 | 0                        | 0    | 0     | 0 | 0                        | 0    | 0     | 0 | 0                        | 0    | 0     | 0 | 1     | 32            |
| 9:30 AM                         | 0                        | 0    | 0     | 0 | 0                        | 1    | 0     | 0 | 1                        | 0    | 0     | 0 | 0                        | 0    | 0     | 0 | 2     | 31            |
| 9:35 AM                         | 0                        | 0    | 0     | 0 | 0                        | 0    | 1     | 0 | 0                        | 0    | 0     | 0 | 0                        | 0    | 0     | 0 | 1     | 31            |
| 9:40 AM                         | 2                        | 0    | 0     | 0 | 0                        | 0    | 1     | 0 | 0                        | 0    | 0     | 0 | 0                        | 0    | 0     | 0 | 3     | 30            |
| 9:45 AM                         | 0                        | 0    | 0     | 0 | 0                        | 0    | 0     | 0 | 0                        | 0    | 0     | 0 | 0                        | 0    | 0     | 0 | 0     | 25            |
| 9:50 AM                         | 0                        | 0    | 0     | 0 | 0                        | 0    | 0     | 0 | 0                        | 0    | 1     | 0 | 0                        | 0    | 0     | 0 | 1     | 22            |
| 9:55 AM                         | 0                        | 0    | 0     | 0 | 0                        | 0    | 1     | 0 | 0                        | 0    | 0     | 0 | 0                        | 0    | 0     | 0 | 1     | 21            |
| 10:00 AM                        | 0                        | 0    | 0     | 0 | 0                        | 0    | 0     | 0 | 0                        | 0    | 0     | 0 | 0                        | 0    | 0     | 0 | 0     | 18            |
| 10:05 AM                        | 0                        | 2    | 0     | 0 | 0                        | 0    | 0     | 0 | 0                        | 0    | 0     | 0 | 0                        | 1    | 0     | 0 | 3     | 20            |
| 10:10 AM                        | 0                        | 0    | 0     | 0 | 1                        | 0    | 1     | 0 | 0                        | 0    | 0     | 0 | 0                        | 0    | 0     | 0 | 2     | 18            |
| 10:15 AM                        | 0                        | 0    | 0     | 0 | 0                        | 0    | 0     | 0 | 0                        | 0    | 0     | 0 | 0                        | 0    | 0     | 0 | 0     | 15            |
| 10:20 AM                        | 0                        | 0    | 0     | 0 | 0                        | 0    | 3     | 0 | 0                        | 0    | 1     | 0 | 0                        | 0    | 0     | 0 | 4     | 18            |
| 10:25 AM                        | 0                        | 0    | 0     | 0 | 0                        | 0    | 0     | 0 | 1                        | 1    | 0     | 0 | 1                        | 0    | 0     | 0 | 3     | 20            |
| 10:30 AM                        | 0                        | 0    | 0     | 0 | 0                        | 0    | 0     | 0 | 0                        | 0    | 0     | 0 | 0                        | 0    | 0     | 0 | 0     | 18            |
| 10:35 AM                        | 0                        | 0    | 0     | 0 | 0                        | 0    | 1     | 0 | 1                        | 0    | 0     | 0 | 0                        | 0    | 0     | 0 | 2     | 19            |
| 10:40 AM                        | 0                        | 0    | 0     | 0 | 0                        | 0    | 0     | 0 | 0                        | 0    | 0     | 0 | 0                        | 0    | 0     | 0 | 0     | 16            |
| 10:45 AM                        | 0                        | 2    | 0     | 0 | 0                        | 0    | 0     | 0 | 0                        | 0    | 0     | 0 | 0                        | 0    | 0     | 0 | 2     | 18            |
| 10:50 AM                        | 0                        | 0    | 0     | 0 | 0                        | 0    | 1     | 0 | 0                        | 0    | 0     | 0 | 0                        | 1    | 0     | 0 | 2     | 19            |
| 10:55 AM                        | 0                        | 0    | 0     | 0 | 0                        | 1    | 0     | 0 | 0                        | 0    | 0     | 0 | 0                        | 0    | 1     | 0 | 2     | 20            |
| 11:00 AM                        | 0                        | 0    | 0     | 0 | 0                        | 0    | 0     | 0 | 0                        | 0    | 0     | 0 | 0                        | 0    | 0     | 0 | 0     | 20            |
| 11:05 AM                        | 0                        | 0    | 0     | 0 | 0                        | 1    | 0     | 0 | 0                        | 0    | 0     | 0 | 0                        | 0    | 0     | 0 | 1     | 18            |
| 11:10 AM                        | 0                        | 0    | 0     | 0 | 0                        | 1    | 0     | 0 | 1                        | 0    | 0     | 0 | 0                        | 0    | 0     | 0 | 2     | 18            |
| 11:15 AM                        | 0                        | 0    | 0     | 0 | 0                        | 1    | 2     | 0 | 0                        | 1    | 0     | 0 | 0                        | 0    | 0     | 0 | 4     | 22            |
| 11:20 AM                        | 1                        | 0    | 0     | 0 | 0                        | 0    | 0     | 0 | 0                        | 0    | 0     | 0 | 0                        | 0    | 0     | 0 | 1     | 19            |
| 11:25 AM                        | 0                        | 0    | 0     | 0 | 0                        | 0    | 0     | 0 | 1                        | 0    | 0     | 0 | 0                        | 0    | 0     | 0 | 1     | 17            |
| 11:30 AM                        | 0                        | 0    | 0     | 0 | 0                        | 0    | 0     | 0 | 1                        | 0    | 0     | 0 | 0                        | 0    | 0     | 0 | 1     | 18            |
| 11:35 AM                        | 0                        | 0    | 0     | 0 | 0                        | 0    | 1     | 0 | 1                        | 0    | 0     | 0 | 0                        | 0    | 0     | 0 | 2     | 18            |
| 11:40 AM                        | 0                        | 0    | 0     | 0 | 0                        | 0    | 1     | 0 | 1                        | 0    | 0     | 0 | 0                        | 1    | 0     | 0 | 3     | 21            |
| 11:45 AM                        | 0                        | 0    | 0     | 0 | 0                        | 2    | 1     | 0 | 3                        | 0    | 0     | 0 | 0                        | 0    | 0     | 0 | 6     | 25            |
| 11:50 AM                        | 0                        | 0    | 0     | 0 | 0                        | 1    | 0     | 0 | 0                        | 0    | 1     | 0 | 0                        | 0    | 0     | 0 | 2     | 25            |
| 11:55 AM                        | 0                        | 0    | 0     | 0 | 0                        | 0    | 0     | 0 | 0                        | 0    | 0     | 0 | 0                        | 0    | 0     | 0 | 0     | 23            |
| 12:00 PM                        | 0                        | 0    | 0     | 0 | 0                        | 0    | 0     | 0 | 0                        | 0    | 0     | 0 | 0                        | 0    | 1     | 0 | 1     | 24            |
| 12:05 PM                        | 0                        | 0    | 0     | 0 | 0                        | 0    | 0     | 0 | 0                        | 0    | 0     | 0 | 0                        | 0    | 0     | 0 | 0     | 23            |
| 12:10 PM                        | 0                        | 0    | 0     | 0 | 0                        | 0    | 0     | 0 | 0                        | 0    | 0     | 0 | 0                        | 0    | 0     | 0 | 0     | 21            |
| 12:15 PM                        | 0                        | 0    | 0     | 0 | 0                        | 0    | 1     | 0 | 0                        | 0    | 0     | 0 | 0                        | 0    | 0     | 0 | 1     | 18            |
| 12:20 PM                        | 0                        | 0    | 0     | 0 | 0                        | 0    | 1     | 0 | 0                        | 0    | 0     | 0 | 0                        | 0    | 0     | 0 | 1     | 18            |
| 12:25 PM                        | 0                        | 0    | 0     | 0 | 0                        | 0    | 0     | 0 | 1                        | 0    | 0     | 0 | 0                        | 0    | 0     | 0 | 1     | 18            |
| 12:30 PM                        | 0                        | 0    | 0     | 0 | 0                        | 0    | 0     | 0 | 0                        | 0    | 0     | 0 | 0                        | 0    | 0     | 0 | 0     | 17            |
| 12:35 PM                        | 0                        | 1    | 0     | 0 | 0                        | 2    | 1     | 0 | 0                        | 0    | 1     | 0 | 0                        | 0    | 0     | 0 | 5     | 20            |
| 12:40 PM                        | 1                        | 0    | 0     | 0 | 0                        | 0    | 0     | 0 | 0                        | 0    | 0     | 0 | 0                        | 0    | 0     | 0 | 1     | 18            |
| 12:45 PM                        | 0                        | 0    | 0     | 0 | 0                        | 0    | 0     | 0 | 0                        | 0    | 0     | 0 | 0                        | 0    | 0     | 0 | 0     | 12            |
| 12:50 PM                        | 0                        | 0    | 1     | 0 | 0                        | 0    | 0     | 0 | 1                        | 0    | 0     | 0 | 0                        | 0    | 0     | 0 | 2     | 12            |
| 12:55 PM                        | 1                        | 0    | 0     | 0 | 0                        | 0    | 2     | 0 | 0                        | 0    | 0     | 0 | 0                        | 0    | 0     | 0 | 3     | 15            |
| 1:00 PM                         | 0                        | 0    | 0     | 0 | 0                        | 1    | 0     | 0 | 0                        | 0    | 0     | 0 | 0                        | 0    | 0     | 0 | 1     | 15            |
| 1:05 PM                         | 1                        | 0    | 0     | 0 | 0                        | 0    | 0     | 0 | 1                        | 0    | 0     | 0 | 0                        | 1    | 0     | 0 | 3     | 18            |
| 1:10 PM                         | 0                        | 0    | 0     | 0 | 0                        | 0    | 1     | 0 | 0                        | 0    | 0     | 0 | 0                        | 0    | 0     | 0 | 1     | 19            |
| 1:15 PM                         | 0                        | 0    | 0     | 0 | 0                        | 0    | 0     | 0 | 0                        | 0    | 0     | 0 | 0                        | 0    | 0     | 0 | 0     | 18            |
| 1:20 PM                         | 0                        | 0    | 0     | 0 | 0                        | 0    | 3     | 0 | 2                        | 1    | 0     | 0 | 0                        | 0    | 0     | 0 | 6     | 23            |
| 1:25 PM                         | 0                        | 1    | 0     | 0 | 0                        | 3    | 1     | 0 | 1                        | 0    | 0     | 0 | 0                        | 0    | 0     | 0 | 6     | 28            |
| 1:30 PM                         | 0                        | 0    | 0     | 0 | 0                        | 0    | 1     | 0 | 0                        | 0    | 0     | 0 | 0                        | 0    | 0     | 0 | 1     | 29            |
| 1:35 PM                         | 0                        | 0    | 0     | 0 | 0                        | 1    | 1     | 0 | 0                        | 0    | 0     | 0 | 0                        | 0    | 0     | 0 | 2     | 26            |
| 1:40 PM                         | 0                        | 0    | 0     | 0 | 0                        | 0    | 0     | 0 | 1                        | 0    | 0     | 0 | 0                        | 0    | 0     | 0 | 1     | 26            |
| 1:45 PM                         | 0                        | 1    | 0     | 0 | 0                        | 1    | 2     | 0 | 0                        | 0    | 0     | 0 | 0                        | 0    | 0     | 0 | 4     | 30            |
| 1:50 PM                         | 1                        | 1    | 0     | 0 | 0                        | 0    | 2     | 0 | 0                        | 0    | 0     | 0 | 0                        | 0    | 0     | 0 | 4     | 32            |
| 1:55 PM                         | 2                        | 2    | 0     | 0 | 0                        | 0    | 0     | 0 | 0                        | 0    | 1     | 0 | 0                        | 0    | 0     | 0 | 5     | 34            |
| 2:00 PM                         | 0                        | 0    | 0     | 0 | 0                        | 0    | 0     | 0 | 0                        | 0    | 0     | 0 | 0                        | 0    | 0     | 0 | 0     | 33            |
| 2:05 PM                         | 0                        | 0    | 0     | 0 | 0                        | 2    | 0     | 0 | 0                        | 0    | 0     | 0 | 0                        | 0    | 0     | 0 | 2     | 32            |
| 2:10 PM                         | 0                        | 0    | 0     | 0 | 0                        | 0    | 0     | 0 | 0                        | 0    | 0     | 0 | 0                        | 0    | 0     | 0 | 0     | 31            |
| 2:15 PM                         | 0                        | 0    | 0     | 0 | 0                        | 1    | 0     | 0 | 0                        | 0    | 0     | 0 | 0                        | 0    | 0     | 0 | 1     | 32            |
| 2:20 PM                         | 0                        | 1    | 0     | 0 | 0                        | 0    | 0     | 0 | 0                        | 0    | 0     | 0 | 0                        | 0    | 0     | 0 | 1     | 27            |
| 2:25 PM                         | 0                        | 0    | 0     | 0 | 0                        | 1    | 2     | 0 | 0                        | 0    | 0     | 0 | 0                        | 0    | 0     | 0 | 3     | 24            |
| 2:30 PM                         | 0                        | 0    | 0     | 0 | 0                        | 0    | 2     | 0 | 2                        | 0    | 1     | 0 | 0                        | 0    | 0     | 0 | 5     | 28            |
| 2:35 PM                         | 0                        | 0    | 0     | 0 | 0                        | 1    | 1     | 0 | 0                        | 0    | 0     | 0 | 0                        | 0    | 0     | 0 | 2     | 28            |
| 2:40 PM                         | 1                        | 0    | 0     | 0 | 0                        | 1    | 1     | 0 | 1                        | 0    | 1     | 0 | 0                        | 0    | 0     | 0 | 5     | 32            |
| 2:45 PM                         | 1                        | 0    | 0     | 0 | 0                        | 0    | 0     | 0 | 0                        | 0    | 0     | 0 | 0                        | 0    | 0     | 0 | 1     | 29            |
| 2:50 PM                         | 0                        | 0    | 0     | 0 | 0                        | 0    | 1     | 0 | 0                        | 0    | 1     | 0 | 0                        | 0    | 0     | 0 | 2     | 27            |
| 2:55 PM                         | 0                        | 0    | 0     | 0 | 0                        | 1    | 4     | 0 | 0                        | 0    | 0     | 0 | 0                        | 0    | 0     | 0 | 5     | 27            |
| 3:00 PM                         | 1                        | 0    | 0     | 0 | 0                        | 1    | 3     | 0 | 1                        | 0    | 0     | 0 | 0                        | 0    | 0     | 0 | 6     | 33            |
| 3:05 PM                         | 1                        | 0    | 0     | 0 | 0                        | 0    | 0     | 0 | 0                        | 0    | 1     | 0 | 0                        | 0    | 0     | 0 | 2     | 33            |
| 3:10 PM                         | 0                        | 0    | 0     | 0 | 0                        | 2    | 1     | 0 | 1                        | 1    | 0     | 0 | 0                        | 0    | 0     | 0 | 5     | 38            |
| 3:15 PM                         | 0                        | 0    | 0     | 0 | 0                        | 1    | 0     | 0 | 0                        | 0    | 1     | 0 | 0                        | 0    | 0     | 0 | 2     | 39            |
| 3:20 PM                         | 0                        | 2    | 0     | 0 | 0                        | 0    | 0     | 0 | 0                        | 0    | 0     | 0 | 0                        | 1    | 0     | 0 | 3     | 41            |
| 3:25 PM                         | 0                        | 0    | 0     | 0 | 0                        | 0    | 0     | 0 | 0                        | 0    | 0     | 0 | 0                        | 0    | 0     | 0 | 0     | 38            |
| 3:30 PM                         | 0                        | 0    | 0     | 0 | 0                        | 0    | 0     | 0 | 0                        | 0    | 0     | 0 | 0                        | 0    | 0     | 0 | 0     | 33            |
| 3:35 PM                         | 0                        | 0    | 0     | 0 | 0                        | 0    | 0     | 0 | 0                        | 0    | 0     | 0 | 0                        | 0    | 0     | 0 | 0     | 31            |
| 3:40 PM                         | 0                        | 0    | 0     | 0 | 0                        | 1    | 0     | 0 | 0                        | 0    | 1     | 0 | 0                        | 0    | 0     | 0 | 2     | 28            |
| 3:45 PM                         | 0                        | 0    | 0     | 0 | 0                        | 0    | 1     | 0 | 0                        | 0    | 0     | 0 | 0                        | 0    | 0     | 0 | 1     | 28            |
| 3:50 PM                         | 0                        | 1    | 0     | 0 | 0                        | 0    | 0     | 0 | 0                        | 0    | 0     | 0 | 0                        | 0    | 0     | 0 | 1     | 27            |
| 3:55 PM                         | 0                        | 0    | 0     | 0 | 0                        | 1    | 0     | 0 | 1                        | 1    | 1     | 0 | 0                        | 0    | 0     | 0 | 4     | 26            |
| 4:00 PM                         | 0                        | 1    | 0     | 0 | 0                        | 0    | 0     | 0 | 0                        | 0    | 0     | 0 | 0                        | 0    | 0     | 0 | 1     | 21            |
| 4:05 PM                         | 0                        | 0    | 0     | 0 | 0                        | 0    | 0     | 0 | 0                        | 1    | 0     | 0 | 0                        | 0    | 0     | 0 | 1     | 20            |
| 4:10 PM                         | 0                        | 1    | 0     | 0 | 0                        | 0    | 0     | 0 | 0                        | 0    | 1     | 0 | 0                        | 0    | 0     | 0 | 2     | 17            |
| 4:15 PM                         | 0                        | 0    | 0     | 0 | 0                        | 0    | 2     | 0 | 1                        | 0    | 0     | 0 | 0                        | 0    | 0     | 0 | 3     | 18            |
| 4:20 PM                         | 0                        | 0    | 0     | 0 | 0                        | 0    | 1     | 0 | 0                        | 0    | 0     | 0 | 0                        | 0    | 0     | 0 | 1     | 16            |
| 4:25 PM                         | 0                        | 1    | 0     | 0 | 0                        | 2    | 1     | 0 | 2                        | 0    | 0     | 0 | 0                        | 0    | 0     | 0 | 6     | 22            |
| 4:30 PM                         | 1                        | 1    | 0     | 0 | 0                        | 0    | 2     | 0 | 2                        | 1    | 0     | 0 | 0                        | 0    | 0     | 0 | 7     | 29            |

**Attachment B**

| 5-Min Count Period Beginning At | Howland Way (Northbound) |      |       |   | Howland Way (Southbound) |      |       |   | Arbolada Way (Eastbound) |      |       |   | Arbolada Way (Westbound) |      |       |   | Total | Hourly Totals |
|---------------------------------|--------------------------|------|-------|---|--------------------------|------|-------|---|--------------------------|------|-------|---|--------------------------|------|-------|---|-------|---------------|
|                                 | Left                     | Thru | Right | U | Left                     | Thru | Right | U | Left                     | Thru | Right | U | Left                     | Thru | Right | U |       |               |
| 4:35 PM                         | 0                        | 0    | 0     | 0 | 0                        | 1    | 1     | 0 | 1                        | 0    | 0     | 0 | 0                        | 0    | 0     | 0 | 3     | 32            |
| 4:40 PM                         | 0                        | 0    | 0     | 0 | 0                        | 1    | 1     | 0 | 0                        | 0    | 1     | 0 | 0                        | 0    | 0     | 0 | 3     | 33            |
| 4:45 PM                         | 0                        | 1    | 0     | 0 | 0                        | 0    | 2     | 0 | 0                        | 0    | 0     | 0 | 0                        | 0    | 0     | 0 | 3     | 35            |
| 4:50 PM                         | 1                        | 0    | 0     | 0 | 0                        | 1    | 0     | 0 | 0                        | 0    | 0     | 0 | 0                        | 0    | 0     | 0 | 2     | 36            |
| 4:55 PM                         | 0                        | 0    | 0     | 0 | 0                        | 1    | 1     | 0 | 0                        | 0    | 0     | 0 | 0                        | 0    | 0     | 0 | 2     | 34            |
| 5:00 PM                         | 0                        | 1    | 0     | 0 | 0                        | 0    | 0     | 0 | 0                        | 0    | 0     | 0 | 0                        | 0    | 0     | 0 | 1     | 34            |
| 5:05 PM                         | 0                        | 0    | 0     | 0 | 0                        | 1    | 0     | 0 | 1                        | 0    | 0     | 0 | 0                        | 0    | 0     | 0 | 2     | 35            |
| 5:10 PM                         | 0                        | 0    | 0     | 0 | 0                        | 0    | 1     | 0 | 2                        | 0    | 0     | 0 | 0                        | 0    | 0     | 0 | 3     | 36            |
| 5:15 PM                         | 0                        | 0    | 0     | 0 | 0                        | 0    | 0     | 0 | 1                        | 0    | 0     | 0 | 0                        | 0    | 0     | 0 | 1     | 34            |
| 5:20 PM                         | 0                        | 0    | 0     | 0 | 0                        | 0    | 1     | 0 | 0                        | 0    | 0     | 0 | 0                        | 0    | 0     | 0 | 1     | 34            |
| 5:25 PM                         | 0                        | 0    | 0     | 0 | 0                        | 1    | 0     | 0 | 1                        | 0    | 0     | 0 | 0                        | 0    | 0     | 0 | 2     | 30            |
| 5:30 PM                         | 0                        | 0    | 0     | 0 | 0                        | 0    | 1     | 0 | 1                        | 0    | 0     | 0 | 0                        | 0    | 0     | 0 | 2     | 25            |
| 5:35 PM                         | 0                        | 0    | 0     | 0 | 0                        | 0    | 0     | 0 | 1                        | 0    | 0     | 0 | 0                        | 0    | 0     | 0 | 1     | 23            |
| 5:40 PM                         | 0                        | 1    | 0     | 0 | 0                        | 1    | 0     | 0 | 0                        | 1    | 0     | 0 | 0                        | 0    | 0     | 0 | 3     | 23            |
| 5:45 PM                         | 1                        | 0    | 0     | 0 | 0                        | 1    | 0     | 0 | 3                        | 0    | 0     | 0 | 0                        | 0    | 0     | 0 | 5     | 25            |
| 5:50 PM                         | 0                        | 1    | 0     | 0 | 0                        | 0    | 1     | 0 | 0                        | 0    | 1     | 0 | 0                        | 0    | 0     | 0 | 3     | 26            |
| 5:55 PM                         | 0                        | 0    | 0     | 0 | 0                        | 1    | 0     | 0 | 1                        | 0    | 0     | 0 | 0                        | 0    | 0     | 0 | 2     | 26            |
| 6:00 PM                         | 0                        | 0    | 0     | 0 | 0                        | 0    | 0     | 0 | 0                        | 0    | 0     | 0 | 0                        | 0    | 0     | 0 | 0     | 25            |
| 6:05 PM                         | 0                        | 1    | 0     | 0 | 0                        | 0    | 0     | 0 | 0                        | 0    | 0     | 0 | 0                        | 0    | 0     | 0 | 1     | 24            |
| 6:10 PM                         | 0                        | 0    | 0     | 0 | 0                        | 0    | 2     | 0 | 1                        | 0    | 0     | 0 | 0                        | 0    | 0     | 0 | 3     | 24            |
| 6:15 PM                         | 0                        | 1    | 0     | 0 | 0                        | 1    | 0     | 0 | 0                        | 0    | 0     | 0 | 0                        | 0    | 0     | 0 | 2     | 25            |
| 6:20 PM                         | 0                        | 0    | 0     | 0 | 0                        | 0    | 2     | 0 | 0                        | 0    | 0     | 0 | 0                        | 0    | 0     | 0 | 2     | 26            |
| 6:25 PM                         | 0                        | 1    | 0     | 0 | 0                        | 1    | 1     | 0 | 2                        | 0    | 0     | 0 | 0                        | 0    | 0     | 0 | 5     | 29            |
| 6:30 PM                         | 0                        | 0    | 0     | 0 | 0                        | 2    | 0     | 0 | 0                        | 0    | 1     | 0 | 0                        | 0    | 0     | 0 | 3     | 30            |
| 6:35 PM                         | 0                        | 1    | 0     | 0 | 0                        | 0    | 1     | 0 | 0                        | 0    | 0     | 0 | 0                        | 0    | 0     | 0 | 2     | 31            |
| 6:40 PM                         | 0                        | 0    | 0     | 0 | 0                        | 2    | 0     | 0 | 0                        | 0    | 0     | 0 | 0                        | 0    | 0     | 0 | 2     | 30            |
| 6:45 PM                         | 0                        | 1    | 0     | 0 | 0                        | 0    | 0     | 0 | 0                        | 0    | 0     | 0 | 0                        | 0    | 0     | 0 | 1     | 26            |
| 6:50 PM                         | 0                        | 0    | 0     | 0 | 0                        | 0    | 0     | 0 | 1                        | 0    | 0     | 0 | 0                        | 0    | 0     | 0 | 1     | 24            |
| 6:55 PM                         | 0                        | 1    | 0     | 0 | 0                        | 0    | 0     | 0 | 0                        | 0    | 0     | 0 | 0                        | 0    | 0     | 0 | 1     | 23            |
| 7:00 PM                         | 0                        | 0    | 0     | 0 | 0                        | 0    | 0     | 0 | 2                        | 0    | 0     | 0 | 0                        | 0    | 0     | 0 | 2     | 25            |
| 7:05 PM                         | 0                        | 0    | 0     | 0 | 0                        | 0    | 0     | 0 | 0                        | 0    | 0     | 0 | 0                        | 0    | 0     | 0 | 0     | 24            |
| 7:10 PM                         | 0                        | 0    | 0     | 0 | 0                        | 0    | 2     | 0 | 1                        | 0    | 0     | 0 | 0                        | 0    | 0     | 0 | 3     | 24            |
| 7:15 PM                         | 0                        | 0    | 0     | 0 | 0                        | 0    | 0     | 0 | 0                        | 0    | 0     | 0 | 0                        | 1    | 0     | 0 | 1     | 23            |
| 7:20 PM                         | 0                        | 0    | 0     | 0 | 0                        | 0    | 1     | 0 | 0                        | 0    | 0     | 0 | 0                        | 0    | 0     | 0 | 1     | 22            |
| 7:25 PM                         | 0                        | 1    | 0     | 0 | 0                        | 1    | 0     | 0 | 1                        | 0    | 0     | 0 | 0                        | 0    | 0     | 0 | 3     | 20            |
| 7:30 PM                         | 1                        | 1    | 0     | 0 | 0                        | 0    | 0     | 0 | 1                        | 0    | 1     | 0 | 0                        | 0    | 0     | 0 | 4     | 21            |
| 7:35 PM                         | 1                        | 0    | 0     | 0 | 0                        | 2    | 1     | 0 | 0                        | 0    | 0     | 0 | 0                        | 0    | 0     | 0 | 4     | 23            |
| 7:40 PM                         | 0                        | 0    | 0     | 0 | 0                        | 0    | 1     | 0 | 1                        | 0    | 0     | 0 | 0                        | 0    | 0     | 0 | 2     | 23            |
| 7:45 PM                         | 0                        | 0    | 0     | 0 | 0                        | 1    | 1     | 0 | 0                        | 0    | 0     | 0 | 0                        | 0    | 0     | 0 | 2     | 24            |
| 7:50 PM                         | 0                        | 0    | 0     | 0 | 0                        | 0    | 0     | 0 | 0                        | 0    | 0     | 0 | 0                        | 0    | 0     | 0 | 0     | 23            |
| 7:55 PM                         | 0                        | 0    | 0     | 0 | 0                        | 0    | 0     | 0 | 0                        | 0    | 0     | 0 | 0                        | 0    | 0     | 0 | 0     | 22            |
| 8:00 PM                         | 1                        | 0    | 0     | 0 | 0                        | 0    | 0     | 0 | 0                        | 0    | 0     | 0 | 0                        | 1    | 0     | 0 | 2     | 22            |
| 8:05 PM                         | 0                        | 0    | 0     | 0 | 0                        | 0    | 0     | 0 | 0                        | 0    | 0     | 0 | 0                        | 0    | 0     | 0 | 0     | 22            |
| 8:10 PM                         | 0                        | 0    | 0     | 0 | 0                        | 1    | 0     | 0 | 0                        | 0    | 0     | 0 | 0                        | 0    | 0     | 0 | 1     | 20            |
| 8:15 PM                         | 0                        | 1    | 0     | 0 | 0                        | 0    | 0     | 0 | 1                        | 0    | 0     | 0 | 0                        | 0    | 0     | 0 | 2     | 21            |
| 8:20 PM                         | 0                        | 0    | 0     | 0 | 0                        | 0    | 0     | 0 | 0                        | 0    | 0     | 0 | 0                        | 0    | 0     | 0 | 0     | 20            |
| 8:25 PM                         | 1                        | 0    | 0     | 0 | 0                        | 0    | 0     | 0 | 0                        | 0    | 0     | 0 | 0                        | 0    | 0     | 0 | 1     | 18            |
| 8:30 PM                         | 0                        | 0    | 0     | 0 | 0                        | 0    | 0     | 0 | 0                        | 0    | 0     | 0 | 0                        | 0    | 0     | 0 | 0     | 14            |
| 8:35 PM                         | 0                        | 0    | 0     | 0 | 0                        | 0    | 0     | 0 | 0                        | 0    | 1     | 0 | 0                        | 0    | 0     | 0 | 1     | 11            |
| 8:40 PM                         | 1                        | 0    | 0     | 0 | 0                        | 0    | 0     | 0 | 0                        | 0    | 0     | 0 | 0                        | 0    | 0     | 0 | 1     | 10            |
| 8:45 PM                         | 0                        | 0    | 0     | 0 | 0                        | 0    | 0     | 0 | 0                        | 0    | 0     | 0 | 0                        | 0    | 0     | 0 | 0     | 8             |
| 8:50 PM                         | 0                        | 2    | 0     | 0 | 0                        | 0    | 0     | 0 | 0                        | 0    | 0     | 0 | 0                        | 0    | 0     | 0 | 2     | 10            |
| 8:55 PM                         | 0                        | 0    | 0     | 0 | 0                        | 0    | 0     | 0 | 0                        | 0    | 0     | 0 | 0                        | 0    | 0     | 0 | 0     | 10            |
| 9:00 PM                         | 1                        | 0    | 0     | 0 | 0                        | 1    | 0     | 0 | 0                        | 0    | 0     | 0 | 0                        | 0    | 0     | 0 | 2     | 10            |
| 9:05 PM                         | 0                        | 0    | 0     | 0 | 0                        | 0    | 0     | 0 | 0                        | 0    | 0     | 0 | 0                        | 0    | 0     | 0 | 0     | 10            |
| 9:10 PM                         | 0                        | 0    | 0     | 0 | 0                        | 0    | 0     | 0 | 0                        | 0    | 0     | 0 | 0                        | 0    | 0     | 0 | 0     | 9             |
| 9:15 PM                         | 0                        | 0    | 0     | 0 | 0                        | 0    | 0     | 0 | 0                        | 0    | 0     | 0 | 0                        | 0    | 0     | 0 | 0     | 7             |
| 9:20 PM                         | 0                        | 0    | 0     | 0 | 0                        | 1    | 1     | 0 | 1                        | 0    | 0     | 0 | 0                        | 0    | 0     | 0 | 3     | 10            |
| 9:25 PM                         | 0                        | 0    | 0     | 0 | 0                        | 0    | 0     | 0 | 0                        | 0    | 0     | 0 | 0                        | 0    | 0     | 0 | 0     | 9             |
| 9:30 PM                         | 0                        | 0    | 0     | 0 | 0                        | 0    | 0     | 0 | 0                        | 0    | 0     | 0 | 0                        | 0    | 0     | 0 | 0     | 9             |
| 9:35 PM                         | 0                        | 0    | 0     | 0 | 0                        | 0    | 0     | 0 | 0                        | 0    | 0     | 0 | 0                        | 0    | 0     | 0 | 0     | 8             |
| 9:40 PM                         | 0                        | 0    | 0     | 0 | 0                        | 0    | 0     | 0 | 0                        | 0    | 0     | 0 | 0                        | 0    | 0     | 0 | 0     | 7             |
| 9:45 PM                         | 0                        | 0    | 0     | 0 | 0                        | 0    | 0     | 0 | 1                        | 0    | 0     | 0 | 0                        | 0    | 0     | 0 | 1     | 8             |
| 9:50 PM                         | 0                        | 0    | 0     | 0 | 0                        | 0    | 0     | 0 | 0                        | 0    | 0     | 0 | 0                        | 0    | 0     | 0 | 0     | 6             |
| 9:55 PM                         | 0                        | 0    | 0     | 0 | 0                        | 0    | 0     | 0 | 0                        | 0    | 0     | 0 | 0                        | 0    | 0     | 0 | 0     | 6             |
| Peak 15-Min Flowrates           | Northbound               |      |       |   | Southbound               |      |       |   | Eastbound                |      |       |   | Westbound                |      |       |   | Total |               |
|                                 | Left                     | Thru | Right | U | Left                     | Thru | Right | U | Left                     | Thru | Right | U | Left                     | Thru | Right | U |       |               |
| All Vehicles                    | 4                        | 4    | 0     | 0 | 0                        | 4    | 20    | 0 | 8                        | 8    | 0     | 0 | 0                        | 4    | 0     | 0 | 52    |               |
| Heavy Trucks                    | 0                        | 0    | 0     | 0 | 0                        | 0    | 4     | 0 | 0                        | 4    | 0     | 0 | 0                        | 4    | 0     | 0 | 12    |               |
| Buses                           |                          |      |       |   |                          |      |       |   |                          |      |       |   |                          |      |       |   |       |               |
| Pedestrians                     |                          | 0    |       |   |                          | 0    |       |   |                          | 0    |       |   |                          | 4    |       |   | 4     |               |
| Bicycles                        | 0                        | 0    | 0     |   | 0                        | 0    | 0     |   | 0                        | 0    | 0     |   | 0                        | 0    | 0     |   | 0     |               |
| Scoters                         |                          |      |       |   |                          |      |       |   |                          |      |       |   |                          |      |       |   |       |               |
| <i>Comments:</i>                |                          |      |       |   |                          |      |       |   |                          |      |       |   |                          |      |       |   |       |               |

LOCATION: Clarissa Ln -- Warren Ave  
 CITY/STATE: North Tustin, CA

QC JOB #: 16966444  
 DATE: Thu, Apr 10 2025

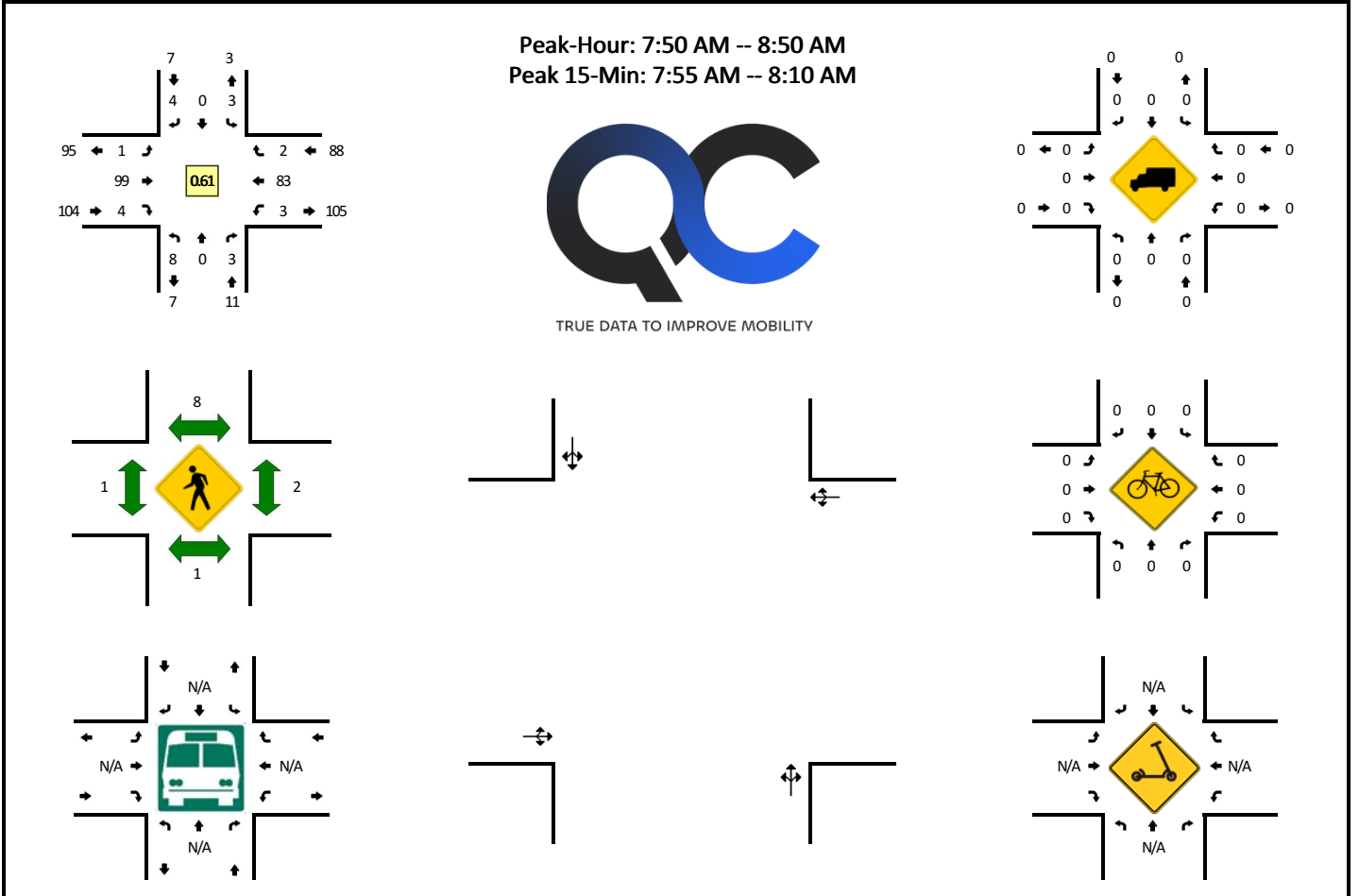

| 5-Min Count Period Beginning At | Clarissa Ln (Northbound) |      |       |   | Clarissa Ln (Southbound) |      |       |   | Warren Ave (Eastbound) |      |       |   | Warren Ave (Westbound) |      |       |   | Total | Hourly Totals |     |
|---------------------------------|--------------------------|------|-------|---|--------------------------|------|-------|---|------------------------|------|-------|---|------------------------|------|-------|---|-------|---------------|-----|
|                                 | Left                     | Thru | Right | U | Left                     | Thru | Right | U | Left                   | Thru | Right | U | Left                   | Thru | Right | U |       |               |     |
| 6:00 AM                         | 0                        | 0    | 1     | 0 | 0                        | 0    | 0     | 0 | 0                      | 0    | 1     | 0 | 0                      | 0    | 0     | 0 | 0     | 2             |     |
| 6:05 AM                         | 0                        | 0    | 0     | 0 | 0                        | 0    | 1     | 0 | 0                      | 0    | 0     | 0 | 0                      | 0    | 2     | 0 | 0     | 3             |     |
| 6:10 AM                         | 0                        | 0    | 0     | 0 | 0                        | 0    | 0     | 0 | 0                      | 1    | 1     | 1 | 0                      | 0    | 2     | 0 | 0     | 5             |     |
| 6:15 AM                         | 1                        | 0    | 0     | 0 | 0                        | 0    | 0     | 0 | 0                      | 0    | 0     | 0 | 0                      | 0    | 3     | 0 | 0     | 4             |     |
| 6:20 AM                         | 2                        | 0    | 0     | 0 | 0                        | 0    | 0     | 0 | 0                      | 0    | 0     | 0 | 0                      | 1    | 1     | 0 | 0     | 4             |     |
| 6:25 AM                         | 0                        | 0    | 0     | 0 | 0                        | 0    | 0     | 0 | 0                      | 0    | 0     | 0 | 0                      | 0    | 1     | 0 | 0     | 1             |     |
| 6:30 AM                         | 1                        | 0    | 0     | 0 | 0                        | 0    | 0     | 0 | 0                      | 0    | 1     | 0 | 0                      | 0    | 1     | 0 | 0     | 3             |     |
| 6:35 AM                         | 1                        | 0    | 0     | 0 | 0                        | 0    | 0     | 0 | 0                      | 0    | 2     | 0 | 0                      | 0    | 1     | 0 | 0     | 4             |     |
| 6:40 AM                         | 0                        | 0    | 0     | 0 | 0                        | 0    | 1     | 0 | 0                      | 0    | 2     | 0 | 0                      | 1    | 1     | 0 | 0     | 5             |     |
| 6:45 AM                         | 1                        | 0    | 0     | 0 | 0                        | 0    | 0     | 0 | 0                      | 0    | 1     | 0 | 0                      | 0    | 1     | 0 | 0     | 3             |     |
| 6:50 AM                         | 2                        | 0    | 0     | 0 | 0                        | 0    | 0     | 0 | 0                      | 0    | 3     | 0 | 0                      | 0    | 1     | 0 | 0     | 6             |     |
| 6:55 AM                         | 2                        | 0    | 0     | 0 | 0                        | 0    | 0     | 0 | 0                      | 0    | 6     | 0 | 0                      | 0    | 5     | 0 | 0     | 13            | 53  |
| 7:00 AM                         | 0                        | 0    | 0     | 0 | 0                        | 0    | 0     | 0 | 0                      | 1    | 2     | 0 | 0                      | 0    | 2     | 0 | 0     | 5             | 56  |
| 7:05 AM                         | 1                        | 0    | 1     | 0 | 0                        | 0    | 0     | 0 | 0                      | 0    | 4     | 1 | 0                      | 0    | 3     | 0 | 0     | 10            | 63  |
| 7:10 AM                         | 1                        | 0    | 0     | 0 | 0                        | 0    | 1     | 0 | 0                      | 0    | 1     | 1 | 0                      | 0    | 3     | 0 | 0     | 7             | 65  |
| 7:15 AM                         | 1                        | 0    | 0     | 0 | 0                        | 0    | 0     | 0 | 0                      | 1    | 4     | 0 | 0                      | 0    | 5     | 0 | 0     | 11            | 72  |
| 7:20 AM                         | 0                        | 0    | 0     | 0 | 0                        | 0    | 0     | 0 | 0                      | 0    | 2     | 0 | 0                      | 0    | 8     | 0 | 0     | 10            | 78  |
| 7:25 AM                         | 0                        | 0    | 1     | 0 | 0                        | 0    | 0     | 0 | 0                      | 0    | 2     | 0 | 0                      | 0    | 4     | 0 | 0     | 7             | 84  |
| 7:30 AM                         | 2                        | 0    | 1     | 0 | 0                        | 0    | 0     | 0 | 0                      | 0    | 1     | 0 | 0                      | 0    | 2     | 0 | 0     | 6             | 87  |
| 7:35 AM                         | 1                        | 0    | 0     | 0 | 0                        | 0    | 1     | 0 | 0                      | 1    | 3     | 1 | 0                      | 0    | 3     | 0 | 0     | 10            | 93  |
| 7:40 AM                         | 1                        | 0    | 1     | 0 | 1                        | 0    | 1     | 0 | 0                      | 0    | 3     | 0 | 0                      | 0    | 0     | 0 | 0     | 7             | 95  |
| 7:45 AM                         | 0                        | 0    | 0     | 0 | 1                        | 0    | 0     | 0 | 0                      | 1    | 7     | 0 | 0                      | 0    | 3     | 0 | 0     | 12            | 104 |
| 7:50 AM                         | 1                        | 0    | 1     | 0 | 0                        | 0    | 0     | 0 | 0                      | 0    | 9     | 0 | 0                      | 0    | 10    | 0 | 0     | 21            | 119 |
| 7:55 AM                         | 2                        | 0    | 1     | 0 | 2                        | 0    | 0     | 0 | 0                      | 0    | 15    | 0 | 0                      | 0    | 7     | 0 | 0     | 27            | 133 |
| 8:00 AM                         | 1                        | 0    | 1     | 0 | 0                        | 0    | 1     | 0 | 0                      | 0    | 15    | 2 | 0                      | 0    | 11    | 0 | 0     | 31            | 159 |
| 8:05 AM                         | 1                        | 0    | 0     | 0 | 0                        | 0    | 0     | 0 | 0                      | 0    | 13    | 0 | 0                      | 1    | 13    | 0 | 0     | 28            | 177 |
| 8:10 AM                         | 1                        | 0    | 0     | 0 | 0                        | 0    | 1     | 0 | 0                      | 0    | 7     | 0 | 0                      | 0    | 14    | 0 | 0     | 23            | 193 |
| 8:15 AM                         | 1                        | 0    | 0     | 0 | 0                        | 0    | 1     | 0 | 0                      | 0    | 2     | 0 | 0                      | 1    | 4     | 0 | 0     | 9             | 191 |
| 8:20 AM                         | 1                        | 0    | 0     | 0 | 0                        | 0    | 0     | 0 | 0                      | 0    | 11    | 1 | 0                      | 0    | 4     | 1 | 0     | 18            | 199 |
| 8:25 AM                         | 0                        | 0    | 0     | 0 | 0                        | 0    | 1     | 0 | 0                      | 0    | 3     | 0 | 0                      | 1    | 4     | 0 | 0     | 9             | 201 |
| 8:30 AM                         | 0                        | 0    | 0     | 0 | 1                        | 0    | 0     | 0 | 0                      | 0    | 4     | 0 | 0                      | 0    | 5     | 0 | 0     | 10            | 205 |
| 8:35 AM                         | 0                        | 0    | 0     | 0 | 0                        | 0    | 0     | 0 | 0                      | 0    | 8     | 0 | 0                      | 0    | 1     | 0 | 0     | 9             | 204 |
| 8:40 AM                         | 0                        | 0    | 0     | 0 | 0                        | 0    | 0     | 0 | 0                      | 0    | 4     | 1 | 0                      | 0    | 6     | 0 | 0     | 11            | 208 |
| 8:45 AM                         | 0                        | 0    | 0     | 0 | 0                        | 0    | 0     | 0 | 0                      | 1    | 8     | 0 | 0                      | 0    | 4     | 1 | 0     | 14            | 210 |
| 8:50 AM                         | 0                        | 0    | 0     | 0 | 0                        | 0    | 0     | 0 | 0                      | 0    | 2     | 0 | 0                      | 0    | 4     | 0 | 0     | 6             | 195 |
| 8:55 AM                         | 1                        | 0    | 0     | 0 | 0                        | 0    | 0     | 0 | 0                      | 0    | 4     | 0 | 0                      | 0    | 8     | 0 | 0     | 13            | 181 |
| 9:00 AM                         | 0                        | 0    | 0     | 0 | 0                        | 0    | 0     | 0 | 0                      | 0    | 3     | 0 | 0                      | 1    | 1     | 0 | 0     | 5             | 155 |
| 9:05 AM                         | 1                        | 0    | 0     | 0 | 0                        | 0    | 0     | 0 | 0                      | 0    | 8     | 0 | 0                      | 0    | 2     | 0 | 0     | 11            | 138 |

Attachment B

| 5-Min Count Period Beginning At | Clarissa Ln (Northbound) |      |       |   | Clarissa Ln (Southbound) |      |       |   | Warren Ave (Eastbound) |      |       |   | Warren Ave (Westbound) |      |       |   | Total | Hourly Totals |
|---------------------------------|--------------------------|------|-------|---|--------------------------|------|-------|---|------------------------|------|-------|---|------------------------|------|-------|---|-------|---------------|
|                                 | Left                     | Thru | Right | U | Left                     | Thru | Right | U | Left                   | Thru | Right | U | Left                   | Thru | Right | U |       |               |
| 9:10 AM                         | 0                        | 0    | 0     | 0 | 1                        | 0    | 0     | 0 | 0                      | 3    | 1     | 0 | 0                      | 3    | 0     | 0 | 8     | 123           |
| 9:15 AM                         | 0                        | 0    | 0     | 0 | 0                        | 0    | 0     | 0 | 0                      | 2    | 0     | 0 | 0                      | 3    | 0     | 0 | 5     | 119           |
| 9:20 AM                         | 0                        | 0    | 0     | 0 | 0                        | 0    | 0     | 0 | 0                      | 2    | 0     | 0 | 0                      | 4    | 0     | 0 | 6     | 107           |
| 9:25 AM                         | 0                        | 0    | 0     | 0 | 0                        | 0    | 0     | 0 | 0                      | 4    | 0     | 0 | 0                      | 3    | 0     | 0 | 7     | 105           |
| 9:30 AM                         | 1                        | 0    | 0     | 0 | 0                        | 0    | 0     | 0 | 0                      | 2    | 0     | 0 | 0                      | 7    | 0     | 0 | 10    | 105           |
| 9:35 AM                         | 2                        | 0    | 0     | 0 | 0                        | 0    | 0     | 0 | 1                      | 3    | 0     | 0 | 1                      | 7    | 0     | 0 | 14    | 110           |
| 9:40 AM                         | 0                        | 0    | 0     | 0 | 0                        | 0    | 0     | 0 | 2                      | 2    | 0     | 0 | 0                      | 7    | 0     | 0 | 11    | 110           |
| 9:45 AM                         | 1                        | 0    | 0     | 0 | 0                        | 0    | 1     | 0 | 0                      | 1    | 0     | 0 | 0                      | 5    | 0     | 0 | 8     | 104           |
| 9:50 AM                         | 1                        | 0    | 0     | 0 | 0                        | 0    | 0     | 0 | 0                      | 5    | 0     | 0 | 0                      | 4    | 0     | 0 | 10    | 108           |
| 9:55 AM                         | 0                        | 0    | 0     | 0 | 0                        | 0    | 0     | 0 | 1                      | 3    | 0     | 0 | 0                      | 3    | 0     | 0 | 7     | 102           |
| 10:00 AM                        | 0                        | 0    | 0     | 0 | 0                        | 0    | 1     | 0 | 0                      | 2    | 0     | 0 | 0                      | 4    | 0     | 0 | 7     | 104           |
| 10:05 AM                        | 0                        | 0    | 0     | 0 | 0                        | 0    | 0     | 0 | 1                      | 5    | 0     | 0 | 0                      | 3    | 0     | 0 | 9     | 102           |
| 10:10 AM                        | 0                        | 0    | 1     | 0 | 0                        | 0    | 0     | 0 | 0                      | 4    | 0     | 0 | 0                      | 3    | 0     | 0 | 8     | 102           |
| 10:15 AM                        | 1                        | 0    | 0     | 0 | 0                        | 0    | 1     | 0 | 1                      | 2    | 1     | 0 | 0                      | 2    | 1     | 0 | 9     | 106           |
| 10:20 AM                        | 0                        | 0    | 1     | 0 | 0                        | 0    | 0     | 0 | 1                      | 2    | 0     | 0 | 0                      | 5    | 0     | 0 | 9     | 109           |
| 10:25 AM                        | 0                        | 0    | 0     | 0 | 0                        | 0    | 0     | 0 | 0                      | 2    | 0     | 0 | 1                      | 3    | 0     | 0 | 6     | 108           |
| 10:30 AM                        | 0                        | 0    | 0     | 0 | 0                        | 0    | 0     | 0 | 0                      | 6    | 1     | 0 | 0                      | 4    | 1     | 0 | 12    | 110           |
| 10:35 AM                        | 0                        | 0    | 1     | 0 | 0                        | 0    | 0     | 0 | 0                      | 3    | 0     | 0 | 0                      | 3    | 0     | 0 | 7     | 103           |
| 10:40 AM                        | 0                        | 0    | 0     | 0 | 0                        | 0    | 1     | 0 | 1                      | 3    | 2     | 0 | 0                      | 4    | 0     | 0 | 11    | 103           |
| 10:45 AM                        | 1                        | 0    | 0     | 0 | 0                        | 0    | 1     | 0 | 0                      | 4    | 0     | 0 | 0                      | 1    | 1     | 0 | 8     | 103           |
| 10:50 AM                        | 1                        | 0    | 0     | 0 | 0                        | 0    | 0     | 0 | 0                      | 4    | 0     | 0 | 0                      | 3    | 0     | 0 | 8     | 101           |
| 10:55 AM                        | 0                        | 0    | 1     | 0 | 0                        | 0    | 1     | 0 | 0                      | 9    | 0     | 0 | 0                      | 2    | 0     | 0 | 13    | 107           |
| 11:00 AM                        | 0                        | 0    | 0     | 0 | 1                        | 0    | 0     | 0 | 1                      | 1    | 0     | 0 | 0                      | 4    | 0     | 0 | 7     | 107           |
| 11:05 AM                        | 1                        | 0    | 0     | 0 | 0                        | 0    | 0     | 0 | 0                      | 2    | 0     | 0 | 0                      | 1    | 0     | 0 | 4     | 102           |
| 11:10 AM                        | 2                        | 0    | 0     | 0 | 0                        | 0    | 1     | 0 | 0                      | 5    | 3     | 0 | 0                      | 1    | 0     | 0 | 10    | 104           |
| 11:15 AM                        | 2                        | 0    | 0     | 0 | 1                        | 0    | 1     | 0 | 2                      | 2    | 0     | 0 | 0                      | 7    | 0     | 0 | 15    | 110           |
| 11:20 AM                        | 0                        | 0    | 0     | 0 | 0                        | 0    | 0     | 0 | 0                      | 3    | 0     | 0 | 0                      | 8    | 0     | 0 | 11    | 112           |
| 11:25 AM                        | 0                        | 0    | 0     | 0 | 0                        | 0    | 3     | 0 | 0                      | 8    | 1     | 0 | 0                      | 7    | 0     | 0 | 19    | 125           |
| 11:30 AM                        | 0                        | 1    | 0     | 0 | 0                        | 0    | 1     | 0 | 0                      | 5    | 1     | 0 | 0                      | 2    | 0     | 0 | 10    | 123           |
| 11:35 AM                        | 1                        | 0    | 1     | 0 | 1                        | 0    | 0     | 0 | 0                      | 2    | 0     | 0 | 0                      | 1    | 0     | 0 | 6     | 122           |
| 11:40 AM                        | 0                        | 0    | 0     | 0 | 1                        | 0    | 0     | 0 | 1                      | 4    | 0     | 0 | 0                      | 2    | 0     | 0 | 8     | 119           |
| 11:45 AM                        | 0                        | 0    | 1     | 0 | 0                        | 0    | 0     | 0 | 0                      | 2    | 0     | 0 | 1                      | 4    | 0     | 0 | 8     | 119           |
| 11:50 AM                        | 0                        | 0    | 0     | 0 | 0                        | 0    | 0     | 0 | 2                      | 4    | 0     | 0 | 0                      | 1    | 0     | 0 | 7     | 118           |
| 11:55 AM                        | 1                        | 0    | 1     | 0 | 0                        | 0    | 0     | 0 | 0                      | 2    | 1     | 0 | 0                      | 6    | 0     | 0 | 11    | 116           |
| 12:00 PM                        | 0                        | 0    | 0     | 0 | 0                        | 0    | 1     | 0 | 1                      | 2    | 0     | 0 | 0                      | 4    | 0     | 0 | 8     | 117           |
| 12:05 PM                        | 0                        | 0    | 0     | 0 | 2                        | 0    | 1     | 0 | 1                      | 4    | 0     | 0 | 0                      | 5    | 0     | 0 | 13    | 126           |
| 12:10 PM                        | 0                        | 0    | 1     | 0 | 0                        | 0    | 0     | 0 | 0                      | 4    | 1     | 0 | 1                      | 6    | 0     | 0 | 13    | 129           |
| 12:15 PM                        | 1                        | 0    | 0     | 0 | 0                        | 0    | 0     | 0 | 0                      | 2    | 0     | 0 | 1                      | 5    | 0     | 0 | 9     | 123           |
| 12:20 PM                        | 0                        | 0    | 0     | 0 | 0                        | 0    | 0     | 0 | 1                      | 5    | 0     | 0 | 0                      | 7    | 0     | 0 | 13    | 125           |
| 12:25 PM                        | 1                        | 0    | 1     | 0 | 0                        | 0    | 0     | 0 | 0                      | 5    | 0     | 0 | 0                      | 3    | 0     | 0 | 10    | 116           |
| 12:30 PM                        | 0                        | 0    | 0     | 0 | 0                        | 0    | 0     | 0 | 0                      | 4    | 0     | 0 | 0                      | 1    | 0     | 0 | 5     | 111           |
| 12:35 PM                        | 0                        | 0    | 0     | 0 | 0                        | 0    | 1     | 0 | 0                      | 1    | 0     | 0 | 0                      | 4    | 0     | 0 | 6     | 111           |
| 12:40 PM                        | 0                        | 0    | 0     | 0 | 0                        | 0    | 0     | 0 | 1                      | 5    | 0     | 0 | 1                      | 3    | 0     | 0 | 10    | 113           |
| 12:45 PM                        | 0                        | 0    | 0     | 0 | 0                        | 0    | 0     | 0 | 0                      | 3    | 1     | 0 | 0                      | 6    | 0     | 0 | 10    | 115           |
| 12:50 PM                        | 0                        | 0    | 0     | 0 | 0                        | 0    | 0     | 0 | 0                      | 1    | 0     | 0 | 1                      | 6    | 0     | 0 | 8     | 116           |
| 12:55 PM                        | 0                        | 0    | 1     | 0 | 0                        | 0    | 1     | 0 | 0                      | 2    | 0     | 0 | 0                      | 6    | 0     | 0 | 10    | 115           |
| 1:00 PM                         | 1                        | 0    | 0     | 0 | 0                        | 0    | 0     | 0 | 0                      | 3    | 0     | 0 | 0                      | 4    | 0     | 0 | 8     | 115           |
| 1:05 PM                         | 0                        | 0    | 0     | 0 | 0                        | 0    | 0     | 0 | 0                      | 1    | 2     | 0 | 1                      | 7    | 0     | 0 | 11    | 113           |
| 1:10 PM                         | 0                        | 0    | 0     | 0 | 0                        | 0    | 0     | 0 | 1                      | 6    | 2     | 0 | 0                      | 3    | 0     | 0 | 12    | 112           |
| 1:15 PM                         | 1                        | 1    | 0     | 0 | 0                        | 0    | 0     | 0 | 2                      | 4    | 0     | 0 | 1                      | 1    | 0     | 0 | 10    | 113           |
| 1:20 PM                         | 0                        | 0    | 0     | 0 | 0                        | 0    | 0     | 0 | 0                      | 0    | 1     | 0 | 0                      | 3    | 0     | 0 | 4     | 104           |
| 1:25 PM                         | 0                        | 0    | 0     | 0 | 1                        | 0    | 0     | 0 | 1                      | 3    | 1     | 0 | 0                      | 2    | 0     | 0 | 8     | 102           |
| 1:30 PM                         | 2                        | 0    | 1     | 0 | 0                        | 0    | 1     | 0 | 0                      | 4    | 1     | 0 | 0                      | 4    | 0     | 0 | 13    | 110           |
| 1:35 PM                         | 0                        | 0    | 0     | 0 | 0                        | 0    | 0     | 0 | 0                      | 4    | 1     | 0 | 0                      | 6    | 0     | 0 | 11    | 115           |
| 1:40 PM                         | 0                        | 0    | 0     | 0 | 0                        | 0    | 0     | 0 | 0                      | 5    | 1     | 0 | 0                      | 5    | 1     | 0 | 12    | 117           |
| 1:45 PM                         | 1                        | 0    | 1     | 0 | 0                        | 0    | 0     | 0 | 0                      | 1    | 0     | 0 | 0                      | 2    | 0     | 0 | 5     | 112           |
| 1:50 PM                         | 1                        | 0    | 0     | 0 | 0                        | 0    | 0     | 0 | 0                      | 4    | 0     | 0 | 1                      | 3    | 0     | 0 | 9     | 113           |
| 1:55 PM                         | 2                        | 0    | 1     | 0 | 0                        | 0    | 0     | 0 | 0                      | 2    | 0     | 0 | 0                      | 6    | 0     | 0 | 11    | 114           |
| 2:00 PM                         | 0                        | 0    | 0     | 0 | 0                        | 0    | 3     | 0 | 0                      | 5    | 0     | 0 | 1                      | 6    | 0     | 0 | 15    | 121           |
| 2:05 PM                         | 1                        | 0    | 1     | 0 | 1                        | 0    | 0     | 0 | 1                      | 5    | 1     | 0 | 0                      | 4    | 0     | 0 | 14    | 124           |
| 2:10 PM                         | 0                        | 0    | 0     | 0 | 0                        | 0    | 0     | 0 | 0                      | 4    | 0     | 0 | 0                      | 0    | 0     | 0 | 4     | 116           |
| 2:15 PM                         | 0                        | 0    | 1     | 0 | 1                        | 0    | 0     | 0 | 1                      | 7    | 1     | 0 | 0                      | 3    | 0     | 0 | 14    | 120           |
| 2:20 PM                         | 0                        | 0    | 0     | 0 | 0                        | 0    | 1     | 0 | 0                      | 7    | 0     | 0 | 1                      | 4    | 0     | 0 | 13    | 129           |
| 2:25 PM                         | 2                        | 0    | 0     | 0 | 0                        | 0    | 0     | 0 | 1                      | 6    | 0     | 0 | 0                      | 7    | 0     | 0 | 16    | 137           |
| 2:30 PM                         | 1                        | 0    | 1     | 0 | 0                        | 0    | 0     | 0 | 0                      | 6    | 0     | 0 | 0                      | 5    | 0     | 0 | 13    | 137           |
| 2:35 PM                         | 0                        | 0    | 0     | 0 | 0                        | 0    | 0     | 0 | 0                      | 2    | 0     | 0 | 0                      | 9    | 0     | 0 | 11    | 137           |
| 2:40 PM                         | 0                        | 0    | 0     | 0 | 0                        | 0    | 0     | 0 | 0                      | 7    | 0     | 0 | 0                      | 13   | 0     | 0 | 20    | 145           |
| 2:45 PM                         | 1                        | 0    | 0     | 0 | 0                        | 0    | 0     | 0 | 0                      | 4    | 0     | 0 | 0                      | 5    | 1     | 0 | 11    | 151           |
| 2:50 PM                         | 0                        | 0    | 0     | 0 | 0                        | 0    | 0     | 0 | 0                      | 5    | 1     | 0 | 0                      | 5    | 0     | 0 | 11    | 153           |
| 2:55 PM                         | 0                        | 0    | 0     | 0 | 0                        | 0    | 0     | 0 | 0                      | 4    | 1     | 0 | 0                      | 8    | 0     | 0 | 13    | 155           |
| 3:00 PM                         | 1                        | 0    | 0     | 0 | 0                        | 0    | 0     | 0 | 0                      | 2    | 1     | 0 | 0                      | 1    | 0     | 0 | 5     | 145           |
| 3:05 PM                         | 0                        | 0    | 0     | 0 | 0                        | 0    | 0     | 0 | 0                      | 2    | 0     | 0 | 0                      | 4    | 0     | 0 | 6     | 137           |
| 3:10 PM                         | 0                        | 0    | 0     | 0 | 0                        | 0    | 0     | 0 | 0                      | 3    | 0     | 0 | 0                      | 2    | 1     | 0 | 6     | 139           |
| 3:15 PM                         | 0                        | 0    | 0     | 0 | 0                        | 0    | 0     | 0 | 0                      | 1    | 3     | 0 | 0                      | 7    | 0     | 0 | 11    | 136           |
| 3:20 PM                         | 0                        | 0    | 0     | 0 | 0                        | 0    | 0     | 0 | 1                      | 8    | 0     | 0 | 0                      | 2    | 0     | 0 | 11    | 134           |
| 3:25 PM                         | 1                        | 0    | 0     | 0 | 0                        | 0    | 0     | 0 | 0                      | 2    | 0     | 0 | 0                      | 7    | 0     | 0 | 10    | 128           |
| 3:30 PM                         | 0                        | 0    | 0     | 0 | 1                        | 0    | 0     | 0 | 0                      | 0    | 0     | 0 | 1                      | 5    | 1     | 0 | 8     | 123           |
| 3:35 PM                         | 1                        | 1    | 0     | 0 | 0                        | 0    | 0     | 0 | 0                      | 7    | 1     | 0 | 0                      | 3    | 0     | 0 | 13    | 125           |
| 3:40 PM                         | 0                        | 0    | 0     | 0 | 0                        | 0    | 1     | 0 | 0                      | 3    | 1     | 0 | 0                      | 7    | 0     | 0 | 12    | 117           |
| 3:45 PM                         | 0                        | 0    | 0     | 0 | 0                        | 0    | 0     | 0 | 2                      | 3    | 0     | 0 | 0                      | 7    | 0     | 0 | 12    | 118           |
| 3:50 PM                         | 1                        | 0    | 0     | 0 | 0                        | 0    | 1     | 0 | 0                      | 3    | 0     | 0 | 0                      | 1    | 0     | 0 | 6     | 113           |
| 3:55 PM                         | 0                        | 0    | 1     | 0 | 0                        | 0    | 2     | 0 | 1                      | 5    | 0     | 0 | 1                      | 7    | 0     | 0 | 17    | 117           |
| 4:00 PM                         | 1                        | 0    | 1     | 0 | 0                        | 0    | 0     | 0 | 0                      | 5    | 1     | 0 | 0                      | 4    | 0     | 0 | 12    | 124           |
| 4:05 PM                         | 0                        | 0    | 0     | 0 | 0                        | 0    | 1     | 0 | 1                      | 3    | 0     | 0 | 0                      | 3    | 0     | 0 | 8     | 126           |
| 4:10 PM                         | 0                        | 0    | 0     | 0 | 0                        | 0    | 0     | 0 | 0                      | 4    | 1     | 0 | 0                      | 9    | 0     | 0 | 14    | 134           |
| 4:15 PM                         | 0                        | 0    | 1     | 0 | 0                        | 0    | 0     | 0 | 0                      | 5    | 1     | 0 | 1                      | 6    | 0     | 0 | 14    | 137           |
| 4:20 PM                         | 0                        | 0    | 0     | 0 | 0                        | 0    | 0     | 0 | 0                      | 6    | 0     | 0 | 0                      | 5    | 0     | 0 | 11    | 137           |
| 4:25 PM                         | 0                        | 0    | 0     | 0 | 0                        | 0    | 0     | 0 | 1                      | 6    | 0     | 0 | 0                      | 5    | 0     | 0 | 12    | 139           |
| 4:30 PM                         | 0                        | 0    | 0     | 0 | 1                        | 0    | 2     | 0 | 1                      | 4    | 2     | 0 | 0                      | 6    | 0     | 0 | 16    | 147           |

## Attachment B

| 5-Min Count Period Beginning At | Clarissa Ln (Northbound) |      |       |   | Clarissa Ln (Southbound) |      |       |   | Warren Ave (Eastbound) |      |       |   | Warren Ave (Westbound) |      |       |   | Total | Hourly Totals |
|---------------------------------|--------------------------|------|-------|---|--------------------------|------|-------|---|------------------------|------|-------|---|------------------------|------|-------|---|-------|---------------|
|                                 | Left                     | Thru | Right | U | Left                     | Thru | Right | U | Left                   | Thru | Right | U | Left                   | Thru | Right | U |       |               |
| 4:35 PM                         | 1                        | 0    | 0     | 0 | 0                        | 0    | 0     | 0 | 0                      | 3    | 0     | 0 | 2                      | 7    | 0     | 0 | 13    | 147           |
| 4:40 PM                         | 0                        | 0    | 0     | 0 | 0                        | 0    | 0     | 0 | 0                      | 4    | 0     | 0 | 0                      | 4    | 0     | 0 | 8     | 143           |
| 4:45 PM                         | 0                        | 0    | 0     | 0 | 0                        | 0    | 0     | 0 | 0                      | 7    | 0     | 0 | 0                      | 6    | 0     | 0 | 13    | 144           |
| 4:50 PM                         | 1                        | 0    | 1     | 0 | 0                        | 0    | 1     | 0 | 0                      | 1    | 1     | 0 | 0                      | 6    | 1     | 0 | 12    | 150           |
| 4:55 PM                         | 1                        | 0    | 1     | 0 | 0                        | 0    | 1     | 0 | 0                      | 7    | 0     | 0 | 0                      | 3    | 0     | 0 | 13    | 146           |
| 5:00 PM                         | 0                        | 0    | 0     | 0 | 0                        | 0    | 0     | 0 | 0                      | 4    | 2     | 0 | 0                      | 8    | 1     | 0 | 15    | 149           |
| 5:05 PM                         | 0                        | 0    | 0     | 0 | 0                        | 0    | 0     | 0 | 1                      | 4    | 0     | 0 | 0                      | 5    | 0     | 0 | 10    | 151           |
| 5:10 PM                         | 0                        | 0    | 0     | 0 | 0                        | 1    | 0     | 0 | 0                      | 6    | 0     | 0 | 0                      | 5    | 1     | 0 | 13    | 150           |
| 5:15 PM                         | 0                        | 0    | 0     | 0 | 0                        | 0    | 0     | 0 | 0                      | 4    | 0     | 0 | 0                      | 3    | 0     | 0 | 7     | 143           |
| 5:20 PM                         | 1                        | 0    | 0     | 0 | 0                        | 0    | 0     | 0 | 0                      | 2    | 0     | 0 | 0                      | 2    | 0     | 0 | 5     | 137           |
| 5:25 PM                         | 0                        | 0    | 0     | 0 | 0                        | 0    | 0     | 0 | 0                      | 4    | 0     | 0 | 1                      | 5    | 0     | 0 | 10    | 135           |
| 5:30 PM                         | 0                        | 0    | 0     | 0 | 0                        | 0    | 0     | 0 | 0                      | 0    | 0     | 0 | 0                      | 3    | 0     | 0 | 3     | 122           |
| 5:35 PM                         | 0                        | 0    | 1     | 0 | 0                        | 0    | 0     | 0 | 1                      | 3    | 3     | 0 | 0                      | 6    | 0     | 0 | 14    | 123           |
| 5:40 PM                         | 1                        | 0    | 0     | 0 | 0                        | 0    | 1     | 0 | 0                      | 5    | 1     | 0 | 1                      | 7    | 2     | 0 | 18    | 133           |
| 5:45 PM                         | 0                        | 0    | 1     | 0 | 0                        | 0    | 0     | 0 | 0                      | 3    | 0     | 0 | 0                      | 2    | 0     | 0 | 6     | 126           |
| 5:50 PM                         | 1                        | 0    | 0     | 0 | 0                        | 0    | 0     | 0 | 0                      | 7    | 1     | 0 | 0                      | 3    | 0     | 0 | 12    | 126           |
| 5:55 PM                         | 0                        | 0    | 0     | 0 | 0                        | 0    | 0     | 0 | 1                      | 5    | 1     | 0 | 0                      | 3    | 0     | 0 | 10    | 123           |
| 6:00 PM                         | 0                        | 0    | 0     | 0 | 0                        | 0    | 0     | 0 | 0                      | 7    | 0     | 0 | 0                      | 4    | 0     | 0 | 11    | 119           |
| 6:05 PM                         | 0                        | 0    | 0     | 0 | 0                        | 0    | 0     | 0 | 0                      | 2    | 1     | 0 | 0                      | 7    | 1     | 0 | 11    | 120           |
| 6:10 PM                         | 0                        | 0    | 0     | 0 | 0                        | 0    | 0     | 0 | 0                      | 4    | 0     | 0 | 0                      | 1    | 2     | 0 | 7     | 114           |
| 6:15 PM                         | 0                        | 0    | 0     | 0 | 0                        | 0    | 1     | 0 | 3                      | 7    | 0     | 0 | 0                      | 4    | 0     | 0 | 15    | 122           |
| 6:20 PM                         | 1                        | 0    | 1     | 0 | 0                        | 1    | 0     | 0 | 0                      | 4    | 0     | 0 | 1                      | 2    | 0     | 0 | 10    | 127           |
| 6:25 PM                         | 0                        | 0    | 0     | 0 | 0                        | 0    | 0     | 0 | 0                      | 8    | 1     | 0 | 0                      | 6    | 0     | 0 | 15    | 132           |
| 6:30 PM                         | 0                        | 0    | 0     | 0 | 0                        | 0    | 1     | 0 | 0                      | 2    | 1     | 0 | 0                      | 2    | 0     | 0 | 6     | 135           |
| 6:35 PM                         | 0                        | 0    | 1     | 0 | 0                        | 0    | 0     | 0 | 0                      | 1    | 0     | 0 | 1                      | 2    | 1     | 0 | 6     | 127           |
| 6:40 PM                         | 0                        | 0    | 0     | 0 | 0                        | 0    | 0     | 0 | 1                      | 5    | 0     | 0 | 1                      | 4    | 0     | 0 | 11    | 120           |
| 6:45 PM                         | 0                        | 0    | 0     | 0 | 0                        | 0    | 0     | 0 | 0                      | 3    | 0     | 0 | 0                      | 4    | 0     | 0 | 7     | 121           |
| 6:50 PM                         | 1                        | 0    | 0     | 0 | 0                        | 0    | 1     | 0 | 0                      | 3    | 0     | 0 | 0                      | 5    | 2     | 0 | 12    | 121           |
| 6:55 PM                         | 1                        | 0    | 0     | 0 | 0                        | 0    | 0     | 0 | 0                      | 2    | 3     | 0 | 0                      | 5    | 0     | 0 | 11    | 122           |
| 7:00 PM                         | 1                        | 0    | 0     | 0 | 1                        | 0    | 0     | 0 | 1                      | 3    | 0     | 0 | 0                      | 2    | 0     | 0 | 8     | 119           |
| 7:05 PM                         | 0                        | 0    | 0     | 0 | 0                        | 0    | 0     | 0 | 0                      | 2    | 0     | 0 | 0                      | 6    | 0     | 0 | 8     | 116           |
| 7:10 PM                         | 1                        | 0    | 0     | 0 | 1                        | 0    | 0     | 0 | 0                      | 3    | 0     | 0 | 1                      | 7    | 0     | 0 | 13    | 122           |
| 7:15 PM                         | 1                        | 0    | 1     | 0 | 1                        | 0    | 1     | 0 | 0                      | 3    | 1     | 0 | 0                      | 4    | 0     | 0 | 12    | 119           |
| 7:20 PM                         | 1                        | 1    | 0     | 0 | 0                        | 0    | 0     | 0 | 0                      | 1    | 1     | 0 | 0                      | 4    | 0     | 0 | 8     | 117           |
| 7:25 PM                         | 0                        | 0    | 0     | 0 | 0                        | 0    | 0     | 0 | 0                      | 4    | 0     | 0 | 1                      | 2    | 0     | 0 | 7     | 109           |
| 7:30 PM                         | 0                        | 0    | 0     | 0 | 0                        | 0    | 0     | 0 | 0                      | 1    | 0     | 0 | 0                      | 4    | 0     | 0 | 5     | 108           |
| 7:35 PM                         | 1                        | 0    | 0     | 0 | 0                        | 0    | 0     | 0 | 0                      | 2    | 0     | 0 | 0                      | 0    | 0     | 0 | 3     | 105           |
| 7:40 PM                         | 0                        | 0    | 0     | 0 | 0                        | 0    | 1     | 0 | 0                      | 2    | 1     | 0 | 0                      | 2    | 0     | 0 | 6     | 100           |
| 7:45 PM                         | 0                        | 0    | 0     | 0 | 0                        | 0    | 0     | 0 | 1                      | 5    | 0     | 0 | 1                      | 2    | 0     | 0 | 9     | 102           |
| 7:50 PM                         | 0                        | 0    | 0     | 0 | 0                        | 0    | 0     | 0 | 0                      | 4    | 0     | 0 | 0                      | 0    | 0     | 0 | 4     | 94            |
| 7:55 PM                         | 0                        | 0    | 2     | 0 | 1                        | 0    | 1     | 0 | 0                      | 5    | 1     | 0 | 1                      | 1    | 0     | 0 | 12    | 95            |
| 8:00 PM                         | 0                        | 0    | 1     | 0 | 0                        | 0    | 0     | 0 | 0                      | 4    | 0     | 0 | 1                      | 1    | 0     | 0 | 7     | 94            |
| 8:05 PM                         | 0                        | 0    | 0     | 0 | 0                        | 0    | 0     | 0 | 0                      | 4    | 0     | 0 | 0                      | 1    | 0     | 0 | 5     | 91            |
| 8:10 PM                         | 0                        | 0    | 0     | 0 | 0                        | 0    | 0     | 0 | 0                      | 3    | 0     | 0 | 0                      | 4    | 0     | 0 | 7     | 85            |
| 8:15 PM                         | 1                        | 0    | 0     | 0 | 0                        | 0    | 0     | 0 | 0                      | 2    | 1     | 0 | 0                      | 2    | 0     | 0 | 6     | 79            |
| 8:20 PM                         | 0                        | 0    | 1     | 0 | 0                        | 0    | 0     | 0 | 0                      | 1    | 0     | 0 | 0                      | 3    | 0     | 0 | 5     | 76            |
| 8:25 PM                         | 0                        | 0    | 0     | 0 | 0                        | 0    | 0     | 0 | 0                      | 1    | 0     | 0 | 0                      | 3    | 0     | 0 | 4     | 73            |
| 8:30 PM                         | 0                        | 0    | 0     | 0 | 0                        | 0    | 0     | 0 | 0                      | 5    | 0     | 0 | 0                      | 2    | 0     | 0 | 7     | 75            |
| 8:35 PM                         | 0                        | 0    | 0     | 0 | 0                        | 0    | 0     | 0 | 0                      | 2    | 1     | 0 | 1                      | 2    | 0     | 0 | 6     | 78            |
| 8:40 PM                         | 0                        | 0    | 1     | 0 | 0                        | 0    | 0     | 0 | 0                      | 4    | 0     | 0 | 0                      | 2    | 0     | 0 | 7     | 79            |
| 8:45 PM                         | 0                        | 0    | 0     | 0 | 0                        | 0    | 0     | 0 | 0                      | 2    | 1     | 0 | 1                      | 3    | 0     | 0 | 7     | 77            |
| 8:50 PM                         | 1                        | 0    | 0     | 0 | 0                        | 0    | 0     | 0 | 0                      | 0    | 0     | 0 | 2                      | 2    | 0     | 0 | 5     | 78            |
| 8:55 PM                         | 0                        | 0    | 0     | 0 | 0                        | 0    | 2     | 0 | 0                      | 1    | 1     | 0 | 0                      | 2    | 0     | 0 | 6     | 72            |
| 9:00 PM                         | 0                        | 0    | 0     | 0 | 0                        | 0    | 0     | 0 | 0                      | 3    | 0     | 0 | 0                      | 0    | 0     | 0 | 3     | 68            |
| 9:05 PM                         | 0                        | 0    | 0     | 0 | 0                        | 0    | 0     | 0 | 0                      | 0    | 0     | 0 | 0                      | 2    | 0     | 0 | 2     | 65            |
| 9:10 PM                         | 0                        | 0    | 0     | 0 | 0                        | 0    | 0     | 0 | 0                      | 1    | 0     | 0 | 0                      | 1    | 0     | 0 | 2     | 60            |
| 9:15 PM                         | 1                        | 0    | 0     | 0 | 0                        | 0    | 0     | 0 | 1                      | 0    | 0     | 0 | 0                      | 1    | 0     | 0 | 3     | 57            |
| 9:20 PM                         | 0                        | 0    | 0     | 0 | 0                        | 0    | 0     | 0 | 0                      | 5    | 0     | 0 | 0                      | 1    | 0     | 0 | 6     | 58            |
| 9:25 PM                         | 0                        | 0    | 0     | 0 | 0                        | 0    | 0     | 0 | 0                      | 3    | 0     | 0 | 0                      | 1    | 0     | 0 | 4     | 58            |
| 9:30 PM                         | 0                        | 0    | 0     | 0 | 0                        | 0    | 0     | 0 | 0                      | 2    | 1     | 0 | 0                      | 0    | 1     | 0 | 4     | 55            |
| 9:35 PM                         | 0                        | 0    | 0     | 0 | 0                        | 0    | 0     | 0 | 0                      | 2    | 0     | 0 | 0                      | 1    | 0     | 0 | 3     | 52            |
| 9:40 PM                         | 2                        | 0    | 2     | 0 | 0                        | 0    | 0     | 0 | 0                      | 0    | 1     | 0 | 0                      | 0    | 0     | 0 | 5     | 50            |
| 9:45 PM                         | 0                        | 0    | 0     | 0 | 0                        | 0    | 0     | 0 | 0                      | 3    | 1     | 0 | 0                      | 0    | 0     | 0 | 4     | 47            |
| 9:50 PM                         | 1                        | 0    | 0     | 0 | 0                        | 0    | 1     | 0 | 0                      | 1    | 0     | 0 | 0                      | 3    | 0     | 0 | 6     | 48            |
| 9:55 PM                         | 0                        | 0    | 0     | 0 | 0                        | 0    | 0     | 0 | 0                      | 2    | 2     | 0 | 1                      | 4    | 0     | 0 | 9     | 51            |
| Peak 15-Min Flowrates           | Northbound               |      |       |   | Southbound               |      |       |   | Eastbound              |      |       |   | Westbound              |      |       |   | Total |               |
|                                 | Left                     | Thru | Right | U | Left                     | Thru | Right | U | Left                   | Thru | Right | U | Left                   | Thru | Right | U |       |               |
| All Vehicles                    | 16                       | 0    | 8     | 0 | 8                        | 0    | 4     | 0 | 0                      | 172  | 8     | 0 | 4                      | 124  | 0     | 0 | 344   |               |
| Heavy Trucks                    | 0                        | 0    | 0     |   | 0                        | 0    | 0     |   | 0                      | 0    | 0     |   | 0                      | 0    | 0     |   | 0     |               |
| Buses                           |                          |      |       |   |                          |      |       |   |                        |      |       |   |                        |      |       |   |       |               |
| Pedestrians                     |                          | 4    |       |   |                          | 4    |       |   |                        | 0    |       |   |                        | 0    |       |   | 8     |               |
| Bicycles                        | 0                        | 0    | 0     |   | 0                        | 0    | 0     |   | 0                      | 0    | 0     |   | 0                      | 0    | 0     |   | 0     |               |
| Scoters                         |                          |      |       |   |                          |      |       |   |                        |      |       |   |                        |      |       |   |       |               |

Comments:

LOCATION: Winthrop St -- Ervin Ln  
 CITY/STATE: North Tustin, CA

QC JOB #: 16966445  
 DATE: Thu, Apr 10 2025

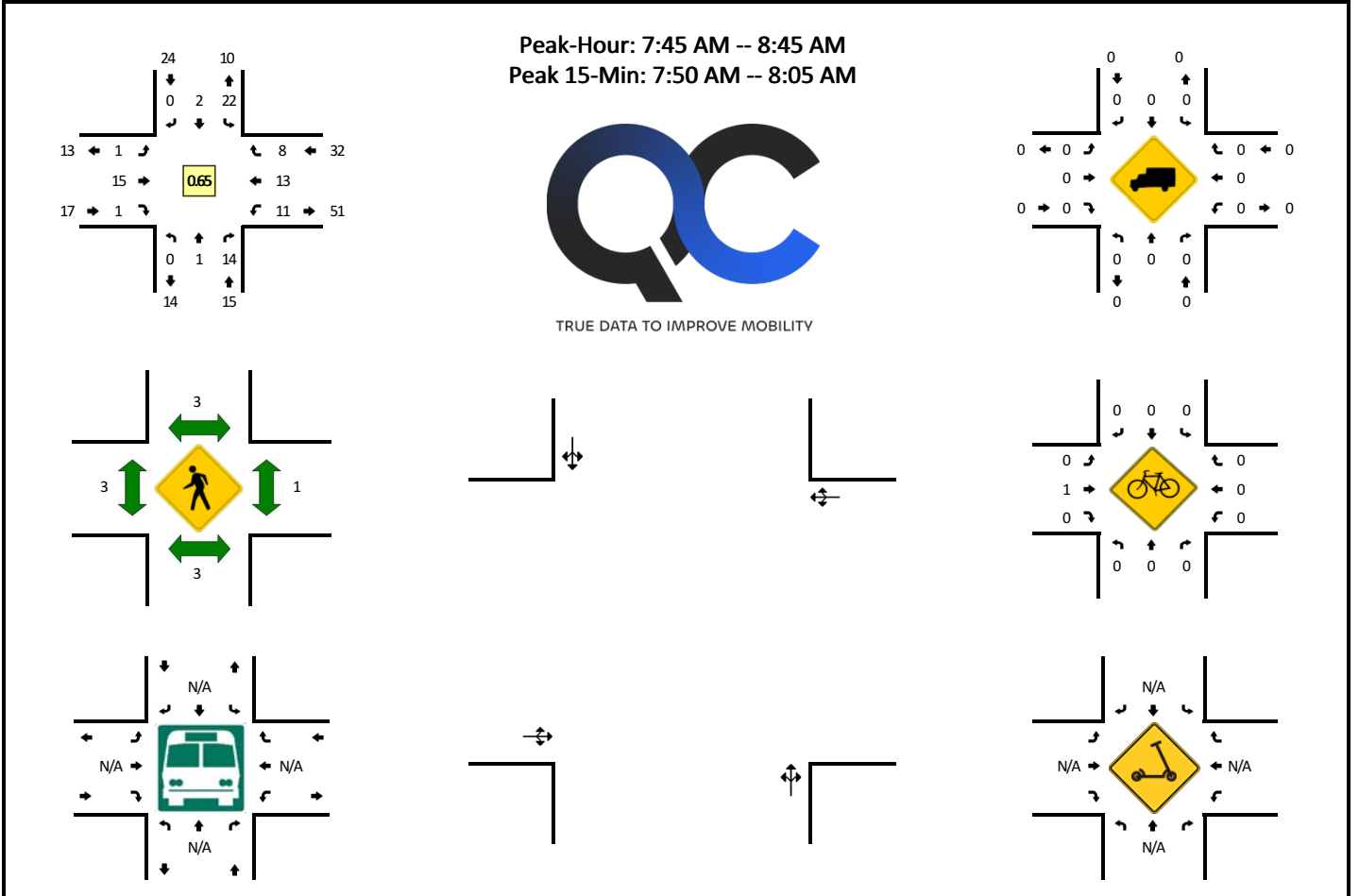

| 5-Min Count Period Beginning At | Winthrop St (Northbound) |      |       |   | Winthrop St (Southbound) |      |       |   | Ervin Ln (Eastbound) |      |       |   | Ervin Ln (Westbound) |      |       |   | Total | Hourly Totals |
|---------------------------------|--------------------------|------|-------|---|--------------------------|------|-------|---|----------------------|------|-------|---|----------------------|------|-------|---|-------|---------------|
|                                 | Left                     | Thru | Right | U | Left                     | Thru | Right | U | Left                 | Thru | Right | U | Left                 | Thru | Right | U |       |               |
| 6:00 AM                         | 0                        | 0    | 0     | 0 | 0                        | 0    | 0     | 0 | 0                    | 0    | 0     | 0 | 0                    | 0    | 0     | 0 | 0     | 0             |
| 6:05 AM                         | 0                        | 0    | 0     | 0 | 0                        | 0    | 0     | 0 | 0                    | 0    | 0     | 0 | 0                    | 0    | 0     | 0 | 0     | 0             |
| 6:10 AM                         | 0                        | 0    | 0     | 0 | 0                        | 0    | 0     | 0 | 0                    | 0    | 0     | 0 | 0                    | 0    | 0     | 0 | 0     | 0             |
| 6:15 AM                         | 0                        | 0    | 0     | 0 | 1                        | 0    | 0     | 0 | 0                    | 0    | 0     | 0 | 0                    | 0    | 0     | 0 | 0     | 1             |
| 6:20 AM                         | 0                        | 0    | 0     | 0 | 1                        | 0    | 0     | 0 | 0                    | 0    | 1     | 0 | 0                    | 0    | 0     | 0 | 0     | 2             |
| 6:25 AM                         | 0                        | 0    | 0     | 0 | 0                        | 0    | 0     | 0 | 0                    | 0    | 1     | 0 | 0                    | 0    | 0     | 0 | 0     | 1             |
| 6:30 AM                         | 0                        | 0    | 0     | 0 | 0                        | 0    | 0     | 0 | 0                    | 0    | 1     | 0 | 0                    | 2    | 0     | 0 | 0     | 3             |
| 6:35 AM                         | 0                        | 0    | 0     | 0 | 0                        | 0    | 0     | 0 | 0                    | 0    | 0     | 0 | 0                    | 0    | 0     | 0 | 0     | 0             |
| 6:40 AM                         | 0                        | 0    | 0     | 0 | 0                        | 0    | 0     | 0 | 0                    | 0    | 1     | 0 | 0                    | 0    | 0     | 0 | 0     | 1             |
| 6:45 AM                         | 0                        | 0    | 0     | 0 | 0                        | 0    | 0     | 0 | 0                    | 0    | 0     | 0 | 0                    | 0    | 0     | 0 | 0     | 0             |
| 6:50 AM                         | 0                        | 0    | 0     | 0 | 1                        | 0    | 0     | 0 | 0                    | 0    | 0     | 0 | 0                    | 0    | 1     | 0 | 0     | 2             |
| 6:55 AM                         | 0                        | 1    | 0     | 0 | 0                        | 0    | 0     | 0 | 0                    | 0    | 2     | 0 | 0                    | 0    | 0     | 0 | 0     | 3             |
| 7:00 AM                         | 0                        | 0    | 0     | 0 | 0                        | 0    | 0     | 0 | 0                    | 0    | 0     | 0 | 0                    | 0    | 0     | 0 | 0     | 0             |
| 7:05 AM                         | 0                        | 0    | 0     | 0 | 1                        | 0    | 0     | 0 | 0                    | 0    | 2     | 0 | 0                    | 0    | 0     | 0 | 0     | 3             |
| 7:10 AM                         | 0                        | 0    | 3     | 0 | 1                        | 0    | 0     | 0 | 0                    | 0    | 3     | 0 | 0                    | 0    | 0     | 0 | 0     | 7             |
| 7:15 AM                         | 0                        | 0    | 2     | 0 | 2                        | 0    | 0     | 0 | 0                    | 0    | 0     | 0 | 1                    | 1    | 0     | 0 | 0     | 6             |
| 7:20 AM                         | 0                        | 0    | 0     | 0 | 0                        | 0    | 0     | 0 | 0                    | 0    | 2     | 0 | 0                    | 0    | 0     | 0 | 0     | 2             |
| 7:25 AM                         | 0                        | 1    | 0     | 0 | 3                        | 0    | 0     | 0 | 0                    | 0    | 1     | 0 | 0                    | 1    | 3     | 1 | 0     | 10            |
| 7:30 AM                         | 0                        | 0    | 0     | 0 | 1                        | 0    | 0     | 0 | 0                    | 0    | 2     | 0 | 0                    | 0    | 1     | 0 | 0     | 4             |
| 7:35 AM                         | 0                        | 0    | 2     | 0 | 0                        | 0    | 0     | 0 | 0                    | 0    | 0     | 0 | 0                    | 0    | 2     | 0 | 0     | 4             |
| 7:40 AM                         | 0                        | 0    | 0     | 0 | 1                        | 0    | 0     | 0 | 0                    | 0    | 1     | 0 | 0                    | 1    | 0     | 0 | 0     | 3             |
| 7:45 AM                         | 0                        | 0    | 2     | 0 | 2                        | 0    | 0     | 0 | 0                    | 0    | 1     | 0 | 0                    | 1    | 0     | 0 | 0     | 6             |
| 7:50 AM                         | 0                        | 0    | 4     | 0 | 5                        | 0    | 0     | 0 | 0                    | 0    | 3     | 0 | 0                    | 0    | 0     | 0 | 0     | 12            |
| 7:55 AM                         | 0                        | 0    | 4     | 0 | 4                        | 0    | 0     | 0 | 0                    | 0    | 1     | 0 | 0                    | 1    | 1     | 1 | 0     | 12            |
| 8:00 AM                         | 0                        | 0    | 2     | 0 | 3                        | 0    | 0     | 0 | 0                    | 0    | 1     | 0 | 0                    | 1    | 2     | 1 | 0     | 10            |
| 8:05 AM                         | 0                        | 0    | 0     | 0 | 2                        | 0    | 0     | 0 | 0                    | 0    | 1     | 0 | 0                    | 2    | 0     | 1 | 0     | 6             |
| 8:10 AM                         | 0                        | 0    | 0     | 0 | 2                        | 0    | 0     | 0 | 0                    | 0    | 2     | 0 | 0                    | 0    | 1     | 2 | 0     | 7             |
| 8:15 AM                         | 0                        | 0    | 0     | 0 | 0                        | 0    | 0     | 0 | 0                    | 0    | 2     | 0 | 0                    | 2    | 2     | 0 | 0     | 6             |
| 8:20 AM                         | 0                        | 0    | 1     | 0 | 1                        | 0    | 0     | 0 | 0                    | 0    | 1     | 0 | 0                    | 1    | 2     | 0 | 0     | 6             |
| 8:25 AM                         | 0                        | 0    | 1     | 0 | 0                        | 0    | 0     | 0 | 0                    | 0    | 1     | 1 | 0                    | 0    | 2     | 1 | 0     | 6             |
| 8:30 AM                         | 0                        | 1    | 0     | 0 | 1                        | 1    | 0     | 0 | 0                    | 0    | 0     | 0 | 0                    | 2    | 0     | 1 | 0     | 6             |
| 8:35 AM                         | 0                        | 0    | 0     | 0 | 2                        | 1    | 0     | 0 | 0                    | 0    | 1     | 0 | 0                    | 0    | 0     | 1 | 0     | 5             |
| 8:40 AM                         | 0                        | 0    | 0     | 0 | 0                        | 0    | 0     | 0 | 0                    | 1    | 1     | 0 | 0                    | 1    | 3     | 0 | 0     | 6             |
| 8:45 AM                         | 0                        | 0    | 0     | 0 | 2                        | 0    | 0     | 0 | 0                    | 0    | 0     | 1 | 0                    | 0    | 0     | 0 | 0     | 3             |
| 8:50 AM                         | 0                        | 0    | 0     | 0 | 0                        | 0    | 0     | 0 | 0                    | 0    | 0     | 0 | 0                    | 0    | 0     | 3 | 0     | 7             |
| 8:55 AM                         | 0                        | 0    | 1     | 0 | 1                        | 0    | 0     | 0 | 0                    | 0    | 0     | 0 | 0                    | 0    | 0     | 1 | 0     | 3             |
| 9:00 AM                         | 0                        | 0    | 1     | 0 | 1                        | 0    | 0     | 0 | 0                    | 0    | 0     | 0 | 0                    | 0    | 0     | 0 | 0     | 2             |
| 9:05 AM                         | 0                        | 0    | 1     | 0 | 1                        | 0    | 0     | 0 | 0                    | 0    | 1     | 0 | 0                    | 0    | 1     | 0 | 0     | 4             |

## Attachment B

| 5-Min Count Period Beginning At | Winthrop St (Northbound) |      |       |   | Winthrop St (Southbound) |      |       |   | Ervin Ln (Eastbound) |      |       |   | Ervin Ln (Westbound) |      |       |   | Total | Hourly Totals |
|---------------------------------|--------------------------|------|-------|---|--------------------------|------|-------|---|----------------------|------|-------|---|----------------------|------|-------|---|-------|---------------|
|                                 | Left                     | Thru | Right | U | Left                     | Thru | Right | U | Left                 | Thru | Right | U | Left                 | Thru | Right | U |       |               |
| 9:10 AM                         | 0                        | 0    | 0     | 0 | 0                        | 0    | 0     | 0 | 0                    | 1    | 0     | 0 | 0                    | 3    | 0     | 0 | 4     | 54            |
| 9:15 AM                         | 0                        | 0    | 0     | 0 | 0                        | 0    | 0     | 0 | 0                    | 0    | 0     | 0 | 1                    | 0    | 1     | 0 | 2     | 50            |
| 9:20 AM                         | 0                        | 0    | 0     | 0 | 1                        | 0    | 0     | 0 | 0                    | 1    | 0     | 0 | 3                    | 0    | 0     | 0 | 5     | 49            |
| 9:25 AM                         | 0                        | 0    | 0     | 0 | 1                        | 0    | 0     | 0 | 0                    | 0    | 0     | 0 | 1                    | 0    | 0     | 0 | 2     | 45            |
| 9:30 AM                         | 0                        | 0    | 1     | 0 | 0                        | 0    | 0     | 0 | 0                    | 0    | 0     | 0 | 1                    | 1    | 2     | 0 | 5     | 44            |
| 9:35 AM                         | 0                        | 0    | 0     | 0 | 1                        | 0    | 0     | 0 | 0                    | 0    | 0     | 0 | 0                    | 0    | 0     | 0 | 1     | 40            |
| 9:40 AM                         | 0                        | 0    | 0     | 0 | 0                        | 1    | 0     | 0 | 0                    | 0    | 0     | 0 | 0                    | 0    | 0     | 0 | 1     | 35            |
| 9:45 AM                         | 0                        | 0    | 0     | 0 | 1                        | 0    | 0     | 0 | 0                    | 1    | 0     | 0 | 0                    | 1    | 1     | 0 | 4     | 36            |
| 9:50 AM                         | 0                        | 0    | 2     | 0 | 0                        | 0    | 0     | 0 | 0                    | 4    | 0     | 0 | 0                    | 0    | 0     | 0 | 6     | 39            |
| 9:55 AM                         | 0                        | 0    | 1     | 0 | 1                        | 0    | 0     | 0 | 0                    | 0    | 0     | 0 | 0                    | 2    | 1     | 0 | 5     | 41            |
| 10:00 AM                        | 0                        | 0    | 1     | 0 | 1                        | 0    | 0     | 0 | 0                    | 1    | 0     | 0 | 0                    | 2    | 2     | 0 | 7     | 46            |
| 10:05 AM                        | 0                        | 0    | 0     | 0 | 1                        | 0    | 0     | 0 | 0                    | 0    | 0     | 0 | 1                    | 0    | 0     | 0 | 2     | 44            |
| 10:10 AM                        | 0                        | 0    | 2     | 0 | 1                        | 0    | 0     | 0 | 0                    | 0    | 0     | 0 | 0                    | 2    | 1     | 0 | 6     | 46            |
| 10:15 AM                        | 0                        | 0    | 1     | 0 | 0                        | 1    | 0     | 0 | 0                    | 2    | 0     | 0 | 1                    | 0    | 1     | 0 | 6     | 50            |
| 10:20 AM                        | 0                        | 0    | 0     | 0 | 0                        | 0    | 0     | 0 | 0                    | 0    | 0     | 0 | 0                    | 0    | 2     | 0 | 2     | 47            |
| 10:25 AM                        | 0                        | 0    | 0     | 0 | 1                        | 0    | 0     | 0 | 0                    | 1    | 0     | 0 | 0                    | 1    | 2     | 0 | 5     | 50            |
| 10:30 AM                        | 0                        | 0    | 0     | 0 | 0                        | 0    | 0     | 0 | 0                    | 2    | 0     | 0 | 0                    | 0    | 1     | 0 | 3     | 48            |
| 10:35 AM                        | 0                        | 0    | 0     | 0 | 0                        | 0    | 0     | 0 | 0                    | 1    | 0     | 0 | 0                    | 0    | 0     | 0 | 1     | 48            |
| 10:40 AM                        | 0                        | 0    | 1     | 0 | 0                        | 0    | 0     | 0 | 0                    | 1    | 0     | 0 | 0                    | 1    | 1     | 0 | 4     | 51            |
| 10:45 AM                        | 0                        | 0    | 0     | 0 | 1                        | 0    | 0     | 0 | 0                    | 0    | 0     | 0 | 0                    | 1    | 1     | 0 | 3     | 50            |
| 10:50 AM                        | 1                        | 0    | 0     | 0 | 0                        | 0    | 0     | 0 | 0                    | 0    | 0     | 0 | 0                    | 2    | 0     | 0 | 3     | 47            |
| 10:55 AM                        | 0                        | 1    | 0     | 0 | 1                        | 0    | 0     | 0 | 0                    | 0    | 0     | 0 | 0                    | 0    | 1     | 0 | 3     | 45            |
| 11:00 AM                        | 0                        | 0    | 0     | 0 | 2                        | 1    | 0     | 0 | 0                    | 0    | 1     | 0 | 0                    | 0    | 1     | 0 | 5     | 43            |
| 11:05 AM                        | 0                        | 0    | 1     | 0 | 1                        | 0    | 0     | 0 | 0                    | 0    | 0     | 0 | 1                    | 3    | 0     | 0 | 6     | 47            |
| 11:10 AM                        | 0                        | 1    | 0     | 0 | 0                        | 0    | 0     | 0 | 0                    | 0    | 0     | 0 | 0                    | 1    | 0     | 0 | 2     | 43            |
| 11:15 AM                        | 0                        | 0    | 0     | 0 | 0                        | 1    | 0     | 0 | 0                    | 2    | 0     | 0 | 0                    | 0    | 2     | 0 | 5     | 42            |
| 11:20 AM                        | 0                        | 1    | 0     | 0 | 0                        | 0    | 0     | 0 | 0                    | 2    | 1     | 0 | 0                    | 1    | 1     | 0 | 6     | 46            |
| 11:25 AM                        | 0                        | 0    | 1     | 0 | 1                        | 0    | 0     | 0 | 0                    | 0    | 0     | 0 | 0                    | 0    | 0     | 0 | 2     | 43            |
| 11:30 AM                        | 0                        | 0    | 0     | 0 | 1                        | 0    | 0     | 0 | 0                    | 0    | 0     | 0 | 2                    | 1    | 0     | 0 | 4     | 44            |
| 11:35 AM                        | 0                        | 0    | 0     | 0 | 0                        | 0    | 0     | 0 | 0                    | 0    | 0     | 0 | 0                    | 1    | 2     | 0 | 3     | 46            |
| 11:40 AM                        | 0                        | 0    | 1     | 0 | 0                        | 0    | 0     | 0 | 0                    | 1    | 0     | 0 | 1                    | 4    | 1     | 0 | 8     | 50            |
| 11:45 AM                        | 0                        | 0    | 2     | 0 | 0                        | 0    | 0     | 0 | 0                    | 1    | 0     | 0 | 1                    | 0    | 0     | 0 | 4     | 51            |
| 11:50 AM                        | 0                        | 0    | 0     | 0 | 1                        | 0    | 0     | 0 | 0                    | 0    | 0     | 0 | 1                    | 1    | 0     | 0 | 3     | 51            |
| 11:55 AM                        | 0                        | 0    | 0     | 0 | 2                        | 0    | 0     | 0 | 0                    | 0    | 0     | 0 | 1                    | 0    | 0     | 0 | 3     | 51            |
| 12:00 PM                        | 0                        | 0    | 1     | 0 | 0                        | 0    | 0     | 0 | 0                    | 3    | 0     | 0 | 0                    | 2    | 0     | 0 | 6     | 52            |
| 12:05 PM                        | 1                        | 0    | 1     | 0 | 1                        | 0    | 0     | 0 | 0                    | 0    | 0     | 0 | 1                    | 1    | 1     | 0 | 6     | 52            |
| 12:10 PM                        | 0                        | 0    | 1     | 0 | 0                        | 0    | 0     | 0 | 0                    | 2    | 0     | 0 | 1                    | 0    | 0     | 0 | 4     | 54            |
| 12:15 PM                        | 1                        | 0    | 2     | 0 | 1                        | 0    | 0     | 0 | 0                    | 2    | 0     | 0 | 0                    | 1    | 0     | 0 | 7     | 56            |
| 12:20 PM                        | 0                        | 0    | 1     | 0 | 1                        | 0    | 0     | 0 | 0                    | 0    | 0     | 0 | 0                    | 0    | 0     | 0 | 2     | 52            |
| 12:25 PM                        | 0                        | 1    | 0     | 0 | 0                        | 0    | 0     | 0 | 0                    | 0    | 0     | 0 | 0                    | 0    | 0     | 0 | 1     | 51            |
| 12:30 PM                        | 0                        | 0    | 0     | 0 | 0                        | 0    | 0     | 0 | 0                    | 0    | 0     | 0 | 1                    | 0    | 2     | 0 | 3     | 50            |
| 12:35 PM                        | 0                        | 0    | 1     | 0 | 1                        | 0    | 0     | 0 | 0                    | 1    | 0     | 0 | 1                    | 0    | 1     | 0 | 5     | 52            |
| 12:40 PM                        | 0                        | 0    | 1     | 0 | 1                        | 1    | 0     | 0 | 1                    | 0    | 0     | 0 | 0                    | 1    | 0     | 0 | 5     | 49            |
| 12:45 PM                        | 0                        | 0    | 3     | 0 | 0                        | 0    | 0     | 0 | 0                    | 0    | 0     | 0 | 0                    | 1    | 2     | 0 | 6     | 51            |
| 12:50 PM                        | 0                        | 0    | 0     | 0 | 2                        | 0    | 0     | 0 | 0                    | 0    | 0     | 0 | 1                    | 1    | 0     | 0 | 4     | 52            |
| 12:55 PM                        | 0                        | 1    | 1     | 0 | 1                        | 0    | 0     | 0 | 0                    | 0    | 0     | 0 | 0                    | 0    | 1     | 0 | 4     | 53            |
| 1:00 PM                         | 0                        | 0    | 2     | 0 | 1                        | 0    | 0     | 0 | 0                    | 0    | 0     | 0 | 1                    | 2    | 0     | 0 | 6     | 53            |
| 1:05 PM                         | 0                        | 0    | 1     | 0 | 0                        | 0    | 0     | 0 | 0                    | 1    | 0     | 0 | 0                    | 0    | 0     | 0 | 2     | 49            |
| 1:10 PM                         | 0                        | 0    | 0     | 0 | 0                        | 0    | 0     | 0 | 0                    | 0    | 0     | 0 | 0                    | 0    | 2     | 0 | 2     | 47            |
| 1:15 PM                         | 0                        | 0    | 0     | 0 | 0                        | 0    | 0     | 0 | 0                    | 0    | 0     | 0 | 0                    | 1    | 2     | 0 | 3     | 43            |
| 1:20 PM                         | 0                        | 0    | 1     | 0 | 0                        | 0    | 0     | 0 | 0                    | 0    | 0     | 0 | 0                    | 4    | 1     | 0 | 6     | 47            |
| 1:25 PM                         | 0                        | 0    | 1     | 0 | 1                        | 0    | 0     | 0 | 0                    | 0    | 0     | 0 | 0                    | 0    | 0     | 0 | 2     | 48            |
| 1:30 PM                         | 0                        | 0    | 0     | 0 | 1                        | 0    | 0     | 0 | 0                    | 0    | 0     | 0 | 2                    | 0    | 2     | 0 | 5     | 50            |
| 1:35 PM                         | 0                        | 0    | 1     | 0 | 1                        | 0    | 0     | 0 | 0                    | 0    | 0     | 0 | 1                    | 0    | 2     | 0 | 5     | 50            |
| 1:40 PM                         | 0                        | 0    | 2     | 0 | 0                        | 0    | 0     | 0 | 0                    | 0    | 0     | 0 | 0                    | 0    | 0     | 0 | 2     | 47            |
| 1:45 PM                         | 0                        | 0    | 0     | 0 | 0                        | 0    | 0     | 0 | 0                    | 0    | 0     | 0 | 1                    | 1    | 0     | 0 | 2     | 43            |
| 1:50 PM                         | 1                        | 0    | 0     | 0 | 1                        | 0    | 0     | 0 | 0                    | 1    | 0     | 0 | 1                    | 1    | 1     | 0 | 6     | 45            |
| 1:55 PM                         | 0                        | 0    | 1     | 0 | 1                        | 0    | 0     | 0 | 0                    | 0    | 0     | 0 | 1                    | 1    | 1     | 0 | 5     | 46            |
| 2:00 PM                         | 0                        | 0    | 0     | 0 | 2                        | 0    | 0     | 0 | 0                    | 0    | 0     | 0 | 1                    | 1    | 1     | 0 | 5     | 45            |
| 2:05 PM                         | 0                        | 0    | 1     | 0 | 1                        | 0    | 0     | 0 | 0                    | 1    | 0     | 0 | 0                    | 2    | 2     | 0 | 7     | 50            |
| 2:10 PM                         | 0                        | 0    | 0     | 0 | 0                        | 0    | 0     | 0 | 0                    | 2    | 0     | 0 | 1                    | 1    | 0     | 0 | 4     | 52            |
| 2:15 PM                         | 0                        | 0    | 0     | 0 | 1                        | 0    | 0     | 0 | 0                    | 1    | 0     | 0 | 0                    | 2    | 0     | 0 | 4     | 53            |
| 2:20 PM                         | 0                        | 0    | 0     | 0 | 2                        | 0    | 0     | 0 | 0                    | 0    | 0     | 0 | 1                    | 0    | 1     | 0 | 4     | 51            |
| 2:25 PM                         | 0                        | 0    | 1     | 0 | 1                        | 0    | 1     | 0 | 0                    | 2    | 0     | 0 | 1                    | 2    | 0     | 0 | 8     | 57            |
| 2:30 PM                         | 0                        | 0    | 0     | 0 | 3                        | 0    | 0     | 0 | 0                    | 0    | 0     | 0 | 0                    | 0    | 1     | 0 | 4     | 56            |
| 2:35 PM                         | 0                        | 0    | 3     | 0 | 0                        | 0    | 0     | 0 | 0                    | 0    | 0     | 0 | 2                    | 1    | 0     | 0 | 6     | 57            |
| 2:40 PM                         | 0                        | 0    | 0     | 0 | 0                        | 0    | 0     | 0 | 0                    | 2    | 0     | 0 | 0                    | 2    | 2     | 0 | 6     | 61            |
| 2:45 PM                         | 0                        | 0    | 0     | 0 | 0                        | 0    | 0     | 0 | 0                    | 1    | 0     | 0 | 2                    | 1    | 1     | 0 | 5     | 64            |
| 2:50 PM                         | 0                        | 0    | 0     | 0 | 0                        | 0    | 0     | 0 | 0                    | 2    | 0     | 0 | 2                    | 1    | 2     | 0 | 7     | 65            |
| 2:55 PM                         | 0                        | 0    | 3     | 0 | 2                        | 0    | 1     | 0 | 0                    | 2    | 0     | 0 | 0                    | 0    | 2     | 0 | 10    | 70            |
| 3:00 PM                         | 0                        | 0    | 1     | 0 | 1                        | 0    | 0     | 0 | 0                    | 2    | 0     | 0 | 2                    | 2    | 3     | 0 | 11    | 76            |
| 3:05 PM                         | 0                        | 0    | 0     | 0 | 2                        | 0    | 0     | 0 | 0                    | 0    | 0     | 0 | 1                    | 1    | 1     | 0 | 5     | 74            |
| 3:10 PM                         | 0                        | 0    | 0     | 0 | 0                        | 0    | 0     | 0 | 0                    | 1    | 0     | 0 | 0                    | 1    | 1     | 0 | 3     | 73            |
| 3:15 PM                         | 0                        | 0    | 0     | 0 | 1                        | 0    | 0     | 0 | 0                    | 0    | 0     | 0 | 2                    | 2    | 1     | 0 | 6     | 75            |
| 3:20 PM                         | 0                        | 0    | 1     | 0 | 1                        | 1    | 0     | 0 | 0                    | 0    | 0     | 0 | 1                    | 3    | 1     | 0 | 8     | 79            |
| 3:25 PM                         | 0                        | 0    | 1     | 0 | 1                        | 0    | 0     | 0 | 0                    | 1    | 0     | 0 | 0                    | 1    | 0     | 0 | 4     | 75            |
| 3:30 PM                         | 0                        | 0    | 2     | 0 | 2                        | 0    | 0     | 0 | 0                    | 1    | 0     | 0 | 3                    | 3    | 2     | 0 | 13    | 84            |
| 3:35 PM                         | 0                        | 0    | 0     | 0 | 1                        | 0    | 0     | 0 | 0                    | 1    | 0     | 0 | 0                    | 1    | 1     | 0 | 4     | 82            |
| 3:40 PM                         | 0                        | 0    | 3     | 0 | 0                        | 0    | 0     | 0 | 0                    | 1    | 0     | 0 | 1                    | 2    | 0     | 0 | 7     | 83            |
| 3:45 PM                         | 0                        | 0    | 0     | 0 | 0                        | 0    | 0     | 0 | 0                    | 1    | 0     | 0 | 0                    | 1    | 2     | 0 | 4     | 82            |
| 3:50 PM                         | 0                        | 0    | 0     | 0 | 1                        | 0    | 0     | 0 | 0                    | 1    | 0     | 0 | 1                    | 1    | 0     | 0 | 4     | 79            |
| 3:55 PM                         | 0                        | 0    | 1     | 0 | 1                        | 1    | 0     | 0 | 1                    | 0    | 0     | 0 | 0                    | 0    | 2     | 0 | 6     | 75            |
| 4:00 PM                         | 0                        | 0    | 2     | 0 | 0                        | 0    | 0     | 0 | 0                    | 0    | 0     | 0 | 0                    | 1    | 4     | 0 | 7     | 71            |
| 4:05 PM                         | 0                        | 0    | 2     | 0 | 0                        | 0    | 0     | 0 | 0                    | 2    | 0     | 0 | 1                    | 0    | 1     | 0 | 6     | 72            |
| 4:10 PM                         | 0                        | 0    | 2     | 0 | 1                        | 0    | 1     | 0 | 0                    | 2    | 0     | 0 | 3                    | 2    | 3     | 0 | 14    | 83            |
| 4:15 PM                         | 0                        | 0    | 0     | 0 | 1                        | 0    | 0     | 0 | 0                    | 1    | 0     | 0 | 0                    | 0    | 1     | 0 | 3     | 80            |
| 4:20 PM                         | 0                        | 0    | 1     | 0 | 2                        | 0    | 0     | 0 | 0                    | 0    | 0     | 0 | 2                    | 2    | 0     | 0 | 7     | 79            |
| 4:25 PM                         | 0                        | 0    | 2     | 0 | 2                        | 0    | 0     | 0 | 0                    | 1    | 0     | 0 | 1                    | 1    | 2     | 0 | 9     | 84            |
| 4:30 PM                         | 0                        | 0    | 1     | 0 | 1                        | 0    | 0     | 0 | 0                    | 1    | 0     | 0 | 1                    | 0    | 2     | 0 | 6     | 77            |

Attachment B

| 5-Min Count Period Beginning At | Winthrop St (Northbound) |      |       |   | Winthrop St (Southbound) |      |       |   | Ervin Ln (Eastbound) |      |       |   | Ervin Ln (Westbound) |      |       |   | Total | Hourly Totals |
|---------------------------------|--------------------------|------|-------|---|--------------------------|------|-------|---|----------------------|------|-------|---|----------------------|------|-------|---|-------|---------------|
|                                 | Left                     | Thru | Right | U | Left                     | Thru | Right | U | Left                 | Thru | Right | U | Left                 | Thru | Right | U |       |               |
| 4:35 PM                         | 0                        | 0    | 4     | 0 | 1                        | 0    | 0     | 0 | 0                    | 2    | 0     | 0 | 0                    | 2    | 0     | 0 | 9     | 82            |
| 4:40 PM                         | 0                        | 0    | 0     | 0 | 0                        | 0    | 0     | 0 | 0                    | 2    | 0     | 0 | 0                    | 1    | 1     | 2 | 6     | 81            |
| 4:45 PM                         | 0                        | 0    | 1     | 0 | 0                        | 1    | 0     | 0 | 0                    | 1    | 0     | 0 | 0                    | 0    | 0     | 2 | 5     | 82            |
| 4:50 PM                         | 0                        | 0    | 1     | 0 | 0                        | 1    | 0     | 0 | 0                    | 1    | 0     | 0 | 0                    | 2    | 1     | 0 | 6     | 84            |
| 4:55 PM                         | 0                        | 0    | 0     | 0 | 1                        | 0    | 0     | 0 | 0                    | 0    | 0     | 0 | 0                    | 1    | 1     | 0 | 3     | 81            |
| 5:00 PM                         | 0                        | 0    | 0     | 0 | 1                        | 0    | 0     | 0 | 0                    | 1    | 0     | 0 | 0                    | 3    | 0     | 0 | 5     | 79            |
| 5:05 PM                         | 0                        | 0    | 0     | 0 | 1                        | 1    | 0     | 0 | 0                    | 1    | 0     | 0 | 0                    | 0    | 1     | 0 | 4     | 77            |
| 5:10 PM                         | 0                        | 0    | 0     | 0 | 0                        | 0    | 0     | 0 | 0                    | 0    | 0     | 0 | 0                    | 0    | 0     | 3 | 3     | 66            |
| 5:15 PM                         | 0                        | 0    | 0     | 0 | 0                        | 0    | 0     | 0 | 0                    | 0    | 0     | 0 | 0                    | 2    | 0     | 2 | 4     | 67            |
| 5:20 PM                         | 0                        | 0    | 1     | 0 | 0                        | 0    | 0     | 0 | 0                    | 3    | 0     | 0 | 0                    | 0    | 0     | 1 | 5     | 65            |
| 5:25 PM                         | 0                        | 0    | 1     | 0 | 1                        | 0    | 0     | 0 | 0                    | 1    | 0     | 0 | 0                    | 0    | 3     | 0 | 6     | 62            |
| 5:30 PM                         | 0                        | 0    | 0     | 0 | 0                        | 0    | 0     | 0 | 0                    | 1    | 0     | 0 | 0                    | 1    | 2     | 2 | 6     | 62            |
| 5:35 PM                         | 0                        | 0    | 1     | 0 | 1                        | 0    | 0     | 0 | 0                    | 1    | 0     | 0 | 0                    | 2    | 0     | 2 | 7     | 60            |
| 5:40 PM                         | 0                        | 0    | 0     | 0 | 1                        | 0    | 0     | 0 | 0                    | 3    | 0     | 0 | 0                    | 1    | 1     | 1 | 7     | 61            |
| 5:45 PM                         | 0                        | 0    | 0     | 0 | 1                        | 0    | 0     | 0 | 0                    | 0    | 0     | 0 | 0                    | 2    | 0     | 0 | 3     | 59            |
| 5:50 PM                         | 0                        | 0    | 2     | 0 | 0                        | 1    | 0     | 0 | 0                    | 0    | 0     | 0 | 0                    | 0    | 0     | 1 | 4     | 57            |
| 5:55 PM                         | 0                        | 0    | 0     | 0 | 0                        | 0    | 0     | 0 | 0                    | 2    | 0     | 0 | 0                    | 0    | 1     | 3 | 6     | 60            |
| 6:00 PM                         | 0                        | 0    | 0     | 0 | 2                        | 0    | 0     | 0 | 0                    | 0    | 0     | 0 | 0                    | 0    | 0     | 0 | 2     | 57            |
| 6:05 PM                         | 0                        | 0    | 0     | 0 | 1                        | 0    | 0     | 0 | 0                    | 0    | 0     | 0 | 0                    | 0    | 1     | 2 | 4     | 57            |
| 6:10 PM                         | 0                        | 1    | 1     | 0 | 3                        | 0    | 0     | 0 | 0                    | 3    | 0     | 0 | 0                    | 1    | 3     | 0 | 12    | 66            |
| 6:15 PM                         | 0                        | 0    | 0     | 0 | 0                        | 0    | 0     | 0 | 0                    | 0    | 0     | 0 | 0                    | 1    | 2     | 1 | 4     | 66            |
| 6:20 PM                         | 0                        | 0    | 0     | 0 | 1                        | 0    | 0     | 0 | 0                    | 0    | 0     | 0 | 0                    | 0    | 2     | 2 | 5     | 66            |
| 6:25 PM                         | 0                        | 0    | 0     | 0 | 2                        | 0    | 0     | 0 | 0                    | 1    | 0     | 0 | 0                    | 0    | 0     | 1 | 4     | 64            |
| 6:30 PM                         | 0                        | 0    | 2     | 0 | 1                        | 1    | 0     | 0 | 0                    | 2    | 0     | 0 | 0                    | 0    | 0     | 1 | 7     | 65            |
| 6:35 PM                         | 0                        | 0    | 0     | 0 | 1                        | 1    | 0     | 0 | 0                    | 0    | 0     | 0 | 0                    | 2    | 2     | 1 | 7     | 65            |
| 6:40 PM                         | 0                        | 0    | 0     | 0 | 0                        | 0    | 0     | 0 | 0                    | 0    | 0     | 0 | 0                    | 0    | 1     | 0 | 1     | 59            |
| 6:45 PM                         | 0                        | 0    | 0     | 0 | 0                        | 0    | 0     | 0 | 0                    | 0    | 0     | 0 | 0                    | 1    | 0     | 2 | 3     | 59            |
| 6:50 PM                         | 0                        | 0    | 0     | 0 | 0                        | 0    | 0     | 0 | 0                    | 0    | 0     | 0 | 0                    | 0    | 1     | 1 | 2     | 57            |
| 6:55 PM                         | 0                        | 0    | 2     | 0 | 0                        | 0    | 0     | 0 | 0                    | 0    | 0     | 0 | 0                    | 1    | 0     | 1 | 4     | 55            |
| 7:00 PM                         | 0                        | 0    | 0     | 0 | 1                        | 0    | 0     | 0 | 0                    | 0    | 0     | 0 | 0                    | 0    | 0     | 0 | 1     | 54            |
| 7:05 PM                         | 0                        | 0    | 0     | 0 | 1                        | 0    | 0     | 0 | 0                    | 2    | 0     | 0 | 0                    | 0    | 0     | 0 | 3     | 53            |
| 7:10 PM                         | 0                        | 0    | 0     | 0 | 0                        | 0    | 0     | 0 | 0                    | 0    | 0     | 0 | 0                    | 1    | 0     | 0 | 1     | 42            |
| 7:15 PM                         | 0                        | 0    | 1     | 0 | 0                        | 0    | 0     | 0 | 0                    | 0    | 0     | 0 | 0                    | 0    | 3     | 0 | 4     | 42            |
| 7:20 PM                         | 0                        | 0    | 0     | 0 | 1                        | 0    | 0     | 0 | 0                    | 1    | 0     | 0 | 0                    | 0    | 0     | 0 | 2     | 39            |
| 7:25 PM                         | 0                        | 0    | 0     | 0 | 0                        | 0    | 0     | 0 | 0                    | 1    | 0     | 0 | 0                    | 0    | 0     | 1 | 2     | 37            |
| 7:30 PM                         | 0                        | 0    | 1     | 0 | 1                        | 0    | 0     | 0 | 0                    | 0    | 0     | 0 | 0                    | 1    | 0     | 2 | 5     | 35            |
| 7:35 PM                         | 0                        | 0    | 0     | 0 | 0                        | 0    | 0     | 0 | 0                    | 1    | 0     | 0 | 0                    | 1    | 2     | 2 | 6     | 34            |
| 7:40 PM                         | 0                        | 0    | 1     | 0 | 0                        | 0    | 0     | 0 | 0                    | 0    | 0     | 0 | 0                    | 2    | 1     | 2 | 6     | 39            |
| 7:45 PM                         | 0                        | 0    | 1     | 0 | 0                        | 0    | 0     | 0 | 0                    | 1    | 0     | 0 | 0                    | 0    | 0     | 0 | 2     | 38            |
| 7:50 PM                         | 0                        | 0    | 1     | 0 | 0                        | 0    | 0     | 0 | 0                    | 0    | 0     | 0 | 0                    | 0    | 1     | 0 | 2     | 38            |
| 7:55 PM                         | 0                        | 0    | 0     | 0 | 2                        | 0    | 0     | 0 | 0                    | 1    | 0     | 0 | 0                    | 0    | 0     | 1 | 4     | 38            |
| 8:00 PM                         | 0                        | 0    | 0     | 0 | 0                        | 0    | 0     | 0 | 0                    | 0    | 0     | 0 | 0                    | 1    | 1     | 1 | 3     | 40            |
| 8:05 PM                         | 0                        | 0    | 0     | 0 | 0                        | 0    | 0     | 0 | 0                    | 0    | 0     | 0 | 0                    | 0    | 1     | 1 | 2     | 39            |
| 8:10 PM                         | 0                        | 0    | 0     | 0 | 0                        | 0    | 0     | 0 | 0                    | 0    | 0     | 0 | 0                    | 1    | 1     | 1 | 3     | 41            |
| 8:15 PM                         | 0                        | 0    | 0     | 0 | 0                        | 0    | 0     | 0 | 0                    | 0    | 0     | 0 | 0                    | 0    | 1     | 0 | 1     | 38            |
| 8:20 PM                         | 0                        | 0    | 1     | 0 | 0                        | 0    | 0     | 0 | 0                    | 0    | 0     | 0 | 0                    | 1    | 0     | 1 | 3     | 39            |
| 8:25 PM                         | 0                        | 0    | 0     | 0 | 1                        | 0    | 0     | 0 | 0                    | 0    | 0     | 0 | 0                    | 0    | 0     | 1 | 2     | 39            |
| 8:30 PM                         | 0                        | 0    | 0     | 0 | 1                        | 0    | 0     | 0 | 0                    | 2    | 0     | 0 | 0                    | 0    | 1     | 0 | 4     | 38            |
| 8:35 PM                         | 0                        | 0    | 0     | 0 | 0                        | 0    | 0     | 0 | 0                    | 1    | 0     | 0 | 0                    | 0    | 2     | 0 | 3     | 35            |
| 8:40 PM                         | 0                        | 0    | 0     | 0 | 0                        | 0    | 0     | 0 | 0                    | 0    | 0     | 0 | 0                    | 0    | 2     | 1 | 3     | 32            |
| 8:45 PM                         | 0                        | 1    | 1     | 0 | 1                        | 1    | 0     | 0 | 0                    | 0    | 0     | 0 | 0                    | 0    | 0     | 0 | 4     | 34            |
| 8:50 PM                         | 0                        | 0    | 0     | 0 | 0                        | 0    | 0     | 0 | 0                    | 0    | 0     | 0 | 0                    | 0    | 0     | 0 | 0     | 32            |
| 8:55 PM                         | 0                        | 0    | 0     | 0 | 0                        | 0    | 0     | 0 | 0                    | 0    | 0     | 0 | 0                    | 0    | 0     | 0 | 0     | 28            |
| 9:00 PM                         | 0                        | 0    | 0     | 0 | 0                        | 0    | 0     | 0 | 0                    | 0    | 0     | 0 | 0                    | 0    | 1     | 0 | 1     | 26            |
| 9:05 PM                         | 0                        | 0    | 1     | 0 | 0                        | 1    | 0     | 0 | 0                    | 0    | 0     | 0 | 0                    | 0    | 0     | 0 | 2     | 26            |
| 9:10 PM                         | 0                        | 0    | 0     | 0 | 0                        | 0    | 0     | 0 | 0                    | 0    | 0     | 0 | 0                    | 3    | 0     | 0 | 3     | 26            |
| 9:15 PM                         | 0                        | 0    | 0     | 0 | 0                        | 0    | 0     | 0 | 0                    | 0    | 0     | 0 | 0                    | 0    | 0     | 0 | 0     | 25            |
| 9:20 PM                         | 0                        | 0    | 0     | 0 | 0                        | 0    | 0     | 0 | 0                    | 0    | 0     | 0 | 0                    | 0    | 0     | 2 | 2     | 24            |
| 9:25 PM                         | 0                        | 0    | 0     | 0 | 1                        | 0    | 0     | 0 | 0                    | 0    | 0     | 0 | 0                    | 0    | 1     | 0 | 2     | 24            |
| 9:30 PM                         | 0                        | 0    | 0     | 0 | 0                        | 0    | 0     | 0 | 0                    | 0    | 0     | 0 | 0                    | 0    | 2     | 0 | 2     | 22            |
| 9:35 PM                         | 0                        | 0    | 0     | 0 | 1                        | 0    | 0     | 0 | 0                    | 0    | 0     | 0 | 0                    | 0    | 1     | 0 | 2     | 21            |
| 9:40 PM                         | 0                        | 0    | 0     | 0 | 0                        | 0    | 0     | 0 | 0                    | 0    | 0     | 0 | 0                    | 0    | 1     | 1 | 2     | 20            |
| 9:45 PM                         | 0                        | 0    | 0     | 0 | 0                        | 0    | 0     | 0 | 0                    | 0    | 0     | 0 | 0                    | 2    | 0     | 0 | 2     | 18            |
| 9:50 PM                         | 0                        | 0    | 0     | 0 | 0                        | 0    | 0     | 0 | 0                    | 0    | 0     | 0 | 0                    | 0    | 0     | 0 | 0     | 18            |
| 9:55 PM                         | 0                        | 0    | 0     | 0 | 0                        | 0    | 0     | 0 | 0                    | 0    | 0     | 0 | 0                    | 0    | 0     | 1 | 1     | 19            |
| Peak 15-Min Flowrates           | Northbound               |      |       |   | Southbound               |      |       |   | Eastbound            |      |       |   | Westbound            |      |       |   | Total |               |
|                                 | Left                     | Thru | Right | U | Left                     | Thru | Right | U | Left                 | Thru | Right | U | Left                 | Thru | Right | U |       |               |
| All Vehicles                    | 0                        | 0    | 40    | 0 | 48                       | 0    | 0     | 0 | 0                    | 20   | 0     | 0 | 8                    | 12   | 8     | 0 | 136   |               |
| Heavy Trucks                    | 0                        | 0    | 0     | 0 | 0                        | 0    | 0     | 0 | 0                    | 0    | 0     | 0 | 0                    | 0    | 0     | 0 | 0     |               |
| Buses                           |                          |      |       |   |                          |      |       |   |                      |      |       |   |                      |      |       |   |       |               |
| Pedestrians                     |                          | 8    |       |   |                          | 0    |       |   |                      | 12   |       |   |                      | 0    |       |   | 20    |               |
| Bicycles                        | 0                        | 0    | 0     |   | 0                        | 0    | 0     |   | 0                    | 4    | 0     |   | 0                    | 0    | 0     |   | 4     |               |
| Scoters                         |                          |      |       |   |                          |      |       |   |                      |      |       |   |                      |      |       |   |       |               |
| <i>Comments:</i>                |                          |      |       |   |                          |      |       |   |                      |      |       |   |                      |      |       |   |       |               |

LOCATION: Kootenay Dr -- Oak Ridge Dr  
 CITY/STATE: North Tustin, CA

QC JOB #: 16966446  
 DATE: Thu, Apr 10 2025

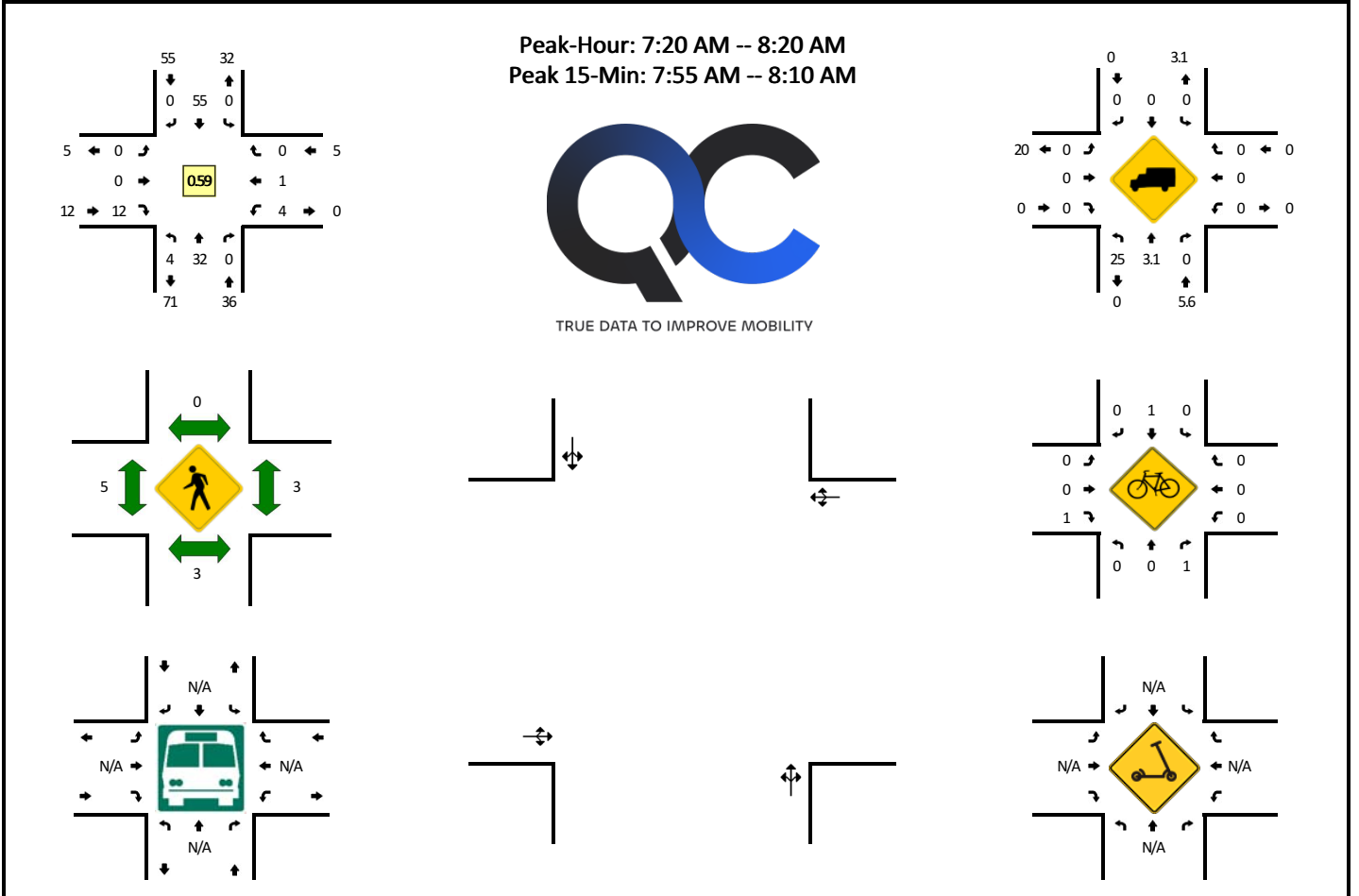

| 5-Min Count Period Beginning At | Kootenay Dr (Northbound) |      |       |   | Kootenay Dr (Southbound) |      |       |   | Oak Ridge Dr (Eastbound) |      |       |   | Oak Ridge Dr (Westbound) |      |       |   | Total | Hourly Totals |
|---------------------------------|--------------------------|------|-------|---|--------------------------|------|-------|---|--------------------------|------|-------|---|--------------------------|------|-------|---|-------|---------------|
|                                 | Left                     | Thru | Right | U | Left                     | Thru | Right | U | Left                     | Thru | Right | U | Left                     | Thru | Right | U |       |               |
| 6:00 AM                         | 0                        | 0    | 0     | 0 | 0                        | 0    | 0     | 0 | 0                        | 0    | 0     | 0 | 0                        | 0    | 0     | 0 | 0     | 0             |
| 6:05 AM                         | 0                        | 0    | 0     | 0 | 0                        | 0    | 0     | 0 | 0                        | 0    | 0     | 0 | 0                        | 0    | 0     | 0 | 0     | 0             |
| 6:10 AM                         | 0                        | 0    | 0     | 0 | 0                        | 1    | 0     | 0 | 0                        | 0    | 0     | 0 | 0                        | 1    | 0     | 0 | 0     | 2             |
| 6:15 AM                         | 0                        | 0    | 0     | 0 | 0                        | 1    | 0     | 0 | 0                        | 0    | 0     | 0 | 0                        | 0    | 0     | 0 | 0     | 1             |
| 6:20 AM                         | 0                        | 0    | 0     | 0 | 0                        | 0    | 0     | 0 | 0                        | 0    | 0     | 0 | 0                        | 0    | 0     | 0 | 0     | 0             |
| 6:25 AM                         | 0                        | 0    | 0     | 0 | 0                        | 1    | 0     | 0 | 0                        | 0    | 0     | 0 | 0                        | 0    | 0     | 0 | 0     | 1             |
| 6:30 AM                         | 1                        | 0    | 0     | 0 | 0                        | 0    | 0     | 0 | 0                        | 0    | 0     | 0 | 0                        | 0    | 0     | 0 | 0     | 1             |
| 6:35 AM                         | 0                        | 0    | 0     | 0 | 0                        | 0    | 0     | 0 | 0                        | 0    | 0     | 0 | 0                        | 1    | 0     | 0 | 0     | 1             |
| 6:40 AM                         | 0                        | 1    | 0     | 0 | 0                        | 0    | 0     | 0 | 0                        | 0    | 1     | 0 | 0                        | 1    | 0     | 0 | 0     | 3             |
| 6:45 AM                         | 0                        | 0    | 0     | 0 | 0                        | 2    | 0     | 0 | 0                        | 0    | 0     | 0 | 0                        | 0    | 0     | 0 | 0     | 2             |
| 6:50 AM                         | 0                        | 1    | 0     | 0 | 0                        | 0    | 0     | 0 | 0                        | 0    | 0     | 1 | 0                        | 0    | 0     | 0 | 0     | 2             |
| 6:55 AM                         | 0                        | 1    | 0     | 0 | 0                        | 1    | 0     | 0 | 0                        | 0    | 0     | 1 | 0                        | 0    | 0     | 0 | 0     | 3             |
| 7:00 AM                         | 0                        | 1    | 0     | 0 | 0                        | 1    | 0     | 0 | 0                        | 0    | 0     | 0 | 0                        | 0    | 0     | 0 | 0     | 2             |
| 7:05 AM                         | 0                        | 3    | 0     | 0 | 0                        | 2    | 0     | 0 | 0                        | 0    | 0     | 1 | 0                        | 0    | 0     | 0 | 0     | 6             |
| 7:10 AM                         | 0                        | 0    | 0     | 0 | 0                        | 4    | 0     | 0 | 0                        | 0    | 0     | 0 | 0                        | 1    | 0     | 0 | 0     | 5             |
| 7:15 AM                         | 1                        | 2    | 0     | 0 | 0                        | 3    | 0     | 0 | 0                        | 0    | 0     | 0 | 0                        | 0    | 0     | 0 | 0     | 6             |
| 7:20 AM                         | 0                        | 4    | 0     | 0 | 0                        | 2    | 0     | 0 | 0                        | 0    | 0     | 0 | 0                        | 0    | 0     | 0 | 0     | 6             |
| 7:25 AM                         | 0                        | 1    | 0     | 0 | 0                        | 3    | 0     | 0 | 0                        | 0    | 0     | 0 | 0                        | 0    | 0     | 0 | 0     | 4             |
| 7:30 AM                         | 0                        | 1    | 0     | 0 | 0                        | 1    | 0     | 0 | 0                        | 0    | 0     | 2 | 0                        | 0    | 0     | 0 | 0     | 4             |
| 7:35 AM                         | 0                        | 4    | 0     | 0 | 0                        | 2    | 0     | 0 | 0                        | 0    | 0     | 0 | 0                        | 1    | 0     | 0 | 0     | 7             |
| 7:40 AM                         | 0                        | 0    | 0     | 0 | 0                        | 5    | 0     | 0 | 0                        | 0    | 0     | 0 | 0                        | 1    | 0     | 0 | 0     | 6             |
| 7:45 AM                         | 1                        | 2    | 0     | 0 | 0                        | 4    | 0     | 0 | 0                        | 0    | 0     | 2 | 0                        | 0    | 0     | 0 | 0     | 9             |
| 7:50 AM                         | 0                        | 1    | 0     | 0 | 0                        | 3    | 0     | 0 | 0                        | 0    | 0     | 1 | 0                        | 0    | 0     | 0 | 0     | 5             |
| 7:55 AM                         | 0                        | 5    | 0     | 0 | 0                        | 9    | 0     | 0 | 0                        | 0    | 0     | 1 | 0                        | 1    | 0     | 0 | 0     | 16            |
| 8:00 AM                         | 0                        | 7    | 0     | 0 | 0                        | 9    | 0     | 0 | 0                        | 0    | 0     | 2 | 0                        | 1    | 0     | 0 | 0     | 19            |
| 8:05 AM                         | 0                        | 2    | 0     | 0 | 0                        | 9    | 0     | 0 | 0                        | 0    | 0     | 0 | 0                        | 0    | 0     | 0 | 0     | 11            |
| 8:10 AM                         | 1                        | 3    | 0     | 0 | 0                        | 4    | 0     | 0 | 0                        | 0    | 0     | 3 | 0                        | 0    | 0     | 0 | 0     | 11            |
| 8:15 AM                         | 2                        | 2    | 0     | 0 | 0                        | 4    | 0     | 0 | 0                        | 0    | 0     | 1 | 0                        | 1    | 0     | 0 | 0     | 10            |
| 8:20 AM                         | 1                        | 3    | 0     | 0 | 0                        | 1    | 0     | 0 | 0                        | 0    | 0     | 0 | 0                        | 0    | 0     | 0 | 0     | 5             |
| 8:25 AM                         | 0                        | 0    | 0     | 0 | 0                        | 1    | 0     | 0 | 0                        | 1    | 0     | 0 | 0                        | 0    | 0     | 0 | 0     | 2             |
| 8:30 AM                         | 0                        | 1    | 1     | 0 | 0                        | 1    | 0     | 0 | 0                        | 0    | 0     | 1 | 0                        | 0    | 0     | 0 | 0     | 4             |
| 8:35 AM                         | 0                        | 4    | 0     | 0 | 0                        | 1    | 0     | 0 | 0                        | 0    | 0     | 1 | 0                        | 0    | 0     | 0 | 0     | 6             |
| 8:40 AM                         | 0                        | 1    | 0     | 0 | 0                        | 1    | 0     | 0 | 0                        | 0    | 0     | 0 | 0                        | 0    | 0     | 0 | 0     | 2             |
| 8:45 AM                         | 1                        | 0    | 0     | 0 | 0                        | 1    | 0     | 0 | 0                        | 0    | 0     | 0 | 0                        | 0    | 0     | 0 | 0     | 2             |
| 8:50 AM                         | 0                        | 0    | 0     | 0 | 0                        | 1    | 0     | 0 | 0                        | 0    | 0     | 0 | 0                        | 0    | 0     | 0 | 0     | 1             |
| 8:55 AM                         | 0                        | 0    | 0     | 0 | 0                        | 0    | 0     | 0 | 0                        | 0    | 0     | 0 | 0                        | 0    | 0     | 0 | 0     | 0             |
| 9:00 AM                         | 0                        | 1    | 0     | 0 | 0                        | 1    | 0     | 0 | 0                        | 0    | 0     | 0 | 0                        | 0    | 0     | 0 | 0     | 2             |
| 9:05 AM                         | 0                        | 0    | 0     | 0 | 0                        | 1    | 0     | 0 | 0                        | 0    | 0     | 0 | 0                        | 0    | 0     | 0 | 0     | 1             |

**Attachment B**

| 5-Min Count Period Beginning At | Kootenay Dr (Northbound) |      |       |   | Kootenay Dr (Southbound) |      |       |   | Oak Ridge Dr (Eastbound) |      |       |   | Oak Ridge Dr (Westbound) |      |       |   | Total | Hourly Totals |
|---------------------------------|--------------------------|------|-------|---|--------------------------|------|-------|---|--------------------------|------|-------|---|--------------------------|------|-------|---|-------|---------------|
|                                 | Left                     | Thru | Right | U | Left                     | Thru | Right | U | Left                     | Thru | Right | U | Left                     | Thru | Right | U |       |               |
| 9:10 AM                         | 0                        | 0    | 0     | 0 | 0                        | 1    | 0     | 0 | 0                        | 0    | 0     | 0 | 0                        | 0    | 0     | 0 | 1     | 36            |
| 9:15 AM                         | 0                        | 3    | 0     | 0 | 0                        | 1    | 0     | 0 | 0                        | 0    | 0     | 0 | 0                        | 0    | 0     | 0 | 4     | 30            |
| 9:20 AM                         | 0                        | 0    | 0     | 0 | 0                        | 2    | 0     | 0 | 0                        | 0    | 0     | 0 | 0                        | 0    | 0     | 0 | 2     | 27            |
| 9:25 AM                         | 2                        | 1    | 0     | 0 | 0                        | 2    | 0     | 0 | 0                        | 0    | 0     | 1 | 0                        | 1    | 0     | 0 | 7     | 32            |
| 9:30 AM                         | 0                        | 1    | 0     | 0 | 0                        | 0    | 0     | 0 | 0                        | 0    | 0     | 1 | 0                        | 0    | 0     | 0 | 2     | 30            |
| 9:35 AM                         | 0                        | 0    | 0     | 0 | 0                        | 0    | 0     | 0 | 0                        | 0    | 0     | 0 | 0                        | 2    | 0     | 0 | 2     | 26            |
| 9:40 AM                         | 1                        | 2    | 0     | 0 | 0                        | 0    | 0     | 0 | 0                        | 0    | 0     | 0 | 0                        | 0    | 0     | 0 | 3     | 27            |
| 9:45 AM                         | 1                        | 1    | 0     | 0 | 0                        | 2    | 0     | 0 | 0                        | 0    | 0     | 0 | 0                        | 0    | 0     | 0 | 4     | 29            |
| 9:50 AM                         | 0                        | 0    | 0     | 0 | 0                        | 0    | 0     | 0 | 0                        | 0    | 0     | 0 | 0                        | 0    | 0     | 0 | 0     | 28            |
| 9:55 AM                         | 0                        | 0    | 2     | 1 | 0                        | 0    | 0     | 0 | 0                        | 0    | 0     | 1 | 0                        | 0    | 0     | 0 | 4     | 32            |
| 10:00 AM                        | 0                        | 1    | 0     | 0 | 0                        | 1    | 0     | 0 | 0                        | 0    | 0     | 0 | 0                        | 1    | 0     | 0 | 3     | 33            |
| 10:05 AM                        | 0                        | 0    | 0     | 0 | 0                        | 1    | 0     | 0 | 0                        | 0    | 0     | 0 | 0                        | 0    | 0     | 0 | 1     | 33            |
| 10:10 AM                        | 0                        | 0    | 0     | 0 | 0                        | 0    | 0     | 0 | 0                        | 0    | 0     | 1 | 0                        | 0    | 0     | 0 | 1     | 33            |
| 10:15 AM                        | 1                        | 0    | 0     | 0 | 0                        | 0    | 0     | 0 | 0                        | 0    | 0     | 1 | 0                        | 0    | 0     | 0 | 2     | 31            |
| 10:20 AM                        | 0                        | 0    | 0     | 0 | 0                        | 3    | 0     | 0 | 0                        | 0    | 0     | 1 | 0                        | 1    | 0     | 0 | 5     | 34            |
| 10:25 AM                        | 0                        | 0    | 0     | 0 | 0                        | 0    | 0     | 0 | 0                        | 0    | 0     | 0 | 0                        | 0    | 0     | 0 | 0     | 27            |
| 10:30 AM                        | 0                        | 2    | 0     | 0 | 0                        | 0    | 0     | 0 | 0                        | 0    | 0     | 1 | 0                        | 0    | 0     | 0 | 3     | 28            |
| 10:35 AM                        | 0                        | 1    | 0     | 0 | 0                        | 1    | 0     | 0 | 0                        | 0    | 0     | 1 | 0                        | 0    | 0     | 0 | 3     | 29            |
| 10:40 AM                        | 2                        | 0    | 0     | 0 | 0                        | 0    | 0     | 0 | 0                        | 0    | 0     | 1 | 0                        | 0    | 0     | 0 | 3     | 29            |
| 10:45 AM                        | 0                        | 1    | 0     | 0 | 0                        | 0    | 0     | 0 | 0                        | 0    | 0     | 1 | 0                        | 0    | 0     | 0 | 2     | 27            |
| 10:50 AM                        | 0                        | 1    | 0     | 0 | 0                        | 0    | 1     | 0 | 0                        | 0    | 0     | 0 | 0                        | 0    | 0     | 0 | 2     | 29            |
| 10:55 AM                        | 0                        | 1    | 1     | 0 | 0                        | 0    | 0     | 0 | 0                        | 0    | 0     | 1 | 0                        | 1    | 0     | 0 | 4     | 29            |
| 11:00 AM                        | 0                        | 1    | 1     | 0 | 0                        | 1    | 0     | 0 | 0                        | 0    | 0     | 1 | 0                        | 2    | 0     | 0 | 6     | 32            |
| 11:05 AM                        | 0                        | 0    | 0     | 0 | 0                        | 0    | 0     | 0 | 0                        | 0    | 0     | 0 | 0                        | 0    | 0     | 0 | 0     | 31            |
| 11:10 AM                        | 0                        | 0    | 0     | 0 | 0                        | 1    | 0     | 0 | 0                        | 0    | 0     | 0 | 0                        | 0    | 0     | 0 | 1     | 31            |
| 11:15 AM                        | 0                        | 0    | 0     | 0 | 0                        | 1    | 0     | 0 | 0                        | 0    | 0     | 0 | 0                        | 0    | 0     | 0 | 1     | 30            |
| 11:20 AM                        | 0                        | 1    | 0     | 0 | 0                        | 1    | 0     | 0 | 0                        | 0    | 0     | 0 | 0                        | 0    | 0     | 0 | 2     | 27            |
| 11:25 AM                        | 0                        | 1    | 1     | 0 | 0                        | 0    | 0     | 0 | 0                        | 0    | 0     | 0 | 0                        | 0    | 0     | 0 | 2     | 29            |
| 11:30 AM                        | 1                        | 0    | 1     | 0 | 0                        | 0    | 0     | 0 | 0                        | 0    | 0     | 1 | 0                        | 0    | 0     | 0 | 3     | 29            |
| 11:35 AM                        | 0                        | 1    | 0     | 0 | 0                        | 0    | 0     | 0 | 0                        | 0    | 0     | 1 | 0                        | 0    | 0     | 0 | 2     | 28            |
| 11:40 AM                        | 0                        | 1    | 1     | 0 | 0                        | 1    | 0     | 0 | 0                        | 0    | 0     | 0 | 0                        | 0    | 0     | 0 | 3     | 28            |
| 11:45 AM                        | 1                        | 3    | 0     | 0 | 0                        | 2    | 0     | 0 | 0                        | 0    | 0     | 0 | 0                        | 0    | 0     | 0 | 6     | 32            |
| 11:50 AM                        | 1                        | 0    | 0     | 0 | 0                        | 3    | 0     | 0 | 0                        | 0    | 0     | 0 | 0                        | 0    | 0     | 0 | 4     | 34            |
| 11:55 AM                        | 1                        | 0    | 0     | 0 | 0                        | 2    | 0     | 0 | 0                        | 0    | 0     | 0 | 0                        | 0    | 0     | 0 | 3     | 33            |
| 12:00 PM                        | 1                        | 1    | 0     | 0 | 0                        | 0    | 0     | 0 | 0                        | 0    | 0     | 0 | 0                        | 0    | 0     | 0 | 2     | 29            |
| 12:05 PM                        | 0                        | 2    | 0     | 0 | 0                        | 5    | 0     | 0 | 0                        | 1    | 0     | 0 | 0                        | 0    | 0     | 0 | 8     | 37            |
| 12:10 PM                        | 0                        | 1    | 0     | 0 | 0                        | 1    | 0     | 0 | 0                        | 0    | 1     | 0 | 0                        | 0    | 0     | 0 | 3     | 39            |
| 12:15 PM                        | 1                        | 0    | 0     | 0 | 0                        | 1    | 0     | 0 | 0                        | 0    | 0     | 2 | 0                        | 0    | 0     | 1 | 5     | 43            |
| 12:20 PM                        | 0                        | 2    | 0     | 0 | 0                        | 0    | 0     | 0 | 0                        | 0    | 0     | 0 | 0                        | 1    | 0     | 0 | 3     | 44            |
| 12:25 PM                        | 0                        | 0    | 0     | 0 | 0                        | 0    | 0     | 0 | 0                        | 0    | 0     | 1 | 0                        | 0    | 0     | 0 | 1     | 43            |
| 12:30 PM                        | 0                        | 1    | 0     | 0 | 0                        | 2    | 0     | 0 | 0                        | 0    | 0     | 0 | 0                        | 0    | 0     | 0 | 3     | 43            |
| 12:35 PM                        | 1                        | 2    | 0     | 0 | 0                        | 1    | 0     | 0 | 0                        | 0    | 0     | 0 | 0                        | 0    | 0     | 0 | 4     | 45            |
| 12:40 PM                        | 1                        | 1    | 1     | 0 | 0                        | 2    | 0     | 0 | 0                        | 0    | 0     | 0 | 0                        | 1    | 0     | 0 | 6     | 48            |
| 12:45 PM                        | 1                        | 2    | 0     | 0 | 0                        | 0    | 0     | 0 | 0                        | 0    | 0     | 0 | 0                        | 1    | 0     | 0 | 4     | 46            |
| 12:50 PM                        | 0                        | 3    | 0     | 0 | 0                        | 1    | 0     | 0 | 0                        | 0    | 0     | 0 | 0                        | 0    | 0     | 0 | 4     | 46            |
| 12:55 PM                        | 0                        | 3    | 0     | 0 | 0                        | 0    | 0     | 0 | 0                        | 0    | 1     | 0 | 0                        | 0    | 0     | 0 | 4     | 47            |
| 1:00 PM                         | 1                        | 1    | 0     | 0 | 0                        | 0    | 0     | 0 | 0                        | 0    | 0     | 0 | 0                        | 0    | 0     | 0 | 2     | 47            |
| 1:05 PM                         | 0                        | 1    | 0     | 0 | 0                        | 0    | 0     | 0 | 0                        | 0    | 0     | 2 | 0                        | 0    | 0     | 0 | 3     | 42            |
| 1:10 PM                         | 0                        | 0    | 0     | 0 | 0                        | 1    | 0     | 0 | 0                        | 0    | 0     | 1 | 0                        | 0    | 0     | 0 | 2     | 41            |
| 1:15 PM                         | 0                        | 2    | 0     | 1 | 0                        | 2    | 0     | 0 | 0                        | 0    | 0     | 0 | 0                        | 0    | 0     | 0 | 5     | 41            |
| 1:20 PM                         | 0                        | 1    | 3     | 0 | 0                        | 2    | 0     | 0 | 0                        | 0    | 1     | 1 | 0                        | 0    | 0     | 0 | 8     | 46            |
| 1:25 PM                         | 1                        | 0    | 0     | 0 | 0                        | 0    | 0     | 0 | 0                        | 1    | 0     | 0 | 0                        | 0    | 0     | 0 | 2     | 47            |
| 1:30 PM                         | 0                        | 0    | 0     | 0 | 0                        | 0    | 0     | 0 | 0                        | 0    | 0     | 0 | 0                        | 1    | 0     | 0 | 1     | 45            |
| 1:35 PM                         | 0                        | 3    | 0     | 0 | 0                        | 2    | 0     | 0 | 0                        | 0    | 0     | 0 | 0                        | 0    | 0     | 0 | 5     | 46            |
| 1:40 PM                         | 0                        | 1    | 0     | 0 | 0                        | 2    | 0     | 0 | 0                        | 0    | 0     | 1 | 0                        | 0    | 0     | 0 | 4     | 44            |
| 1:45 PM                         | 0                        | 2    | 0     | 0 | 0                        | 0    | 0     | 0 | 0                        | 0    | 0     | 0 | 0                        | 0    | 0     | 0 | 2     | 42            |
| 1:50 PM                         | 1                        | 3    | 1     | 0 | 0                        | 2    | 0     | 0 | 0                        | 0    | 0     | 1 | 0                        | 0    | 0     | 0 | 8     | 46            |
| 1:55 PM                         | 0                        | 4    | 0     | 0 | 0                        | 1    | 0     | 0 | 0                        | 0    | 0     | 0 | 0                        | 1    | 0     | 0 | 6     | 48            |
| 2:00 PM                         | 1                        | 1    | 0     | 0 | 0                        | 7    | 0     | 0 | 0                        | 0    | 0     | 2 | 0                        | 0    | 0     | 0 | 11    | 57            |
| 2:05 PM                         | 0                        | 1    | 0     | 0 | 0                        | 1    | 0     | 0 | 0                        | 0    | 0     | 0 | 0                        | 0    | 0     | 0 | 2     | 56            |
| 2:10 PM                         | 0                        | 0    | 0     | 0 | 0                        | 3    | 0     | 0 | 0                        | 0    | 0     | 0 | 0                        | 0    | 0     | 0 | 3     | 57            |
| 2:15 PM                         | 0                        | 1    | 0     | 0 | 0                        | 0    | 0     | 0 | 0                        | 0    | 0     | 0 | 0                        | 0    | 0     | 0 | 1     | 53            |
| 2:20 PM                         | 2                        | 2    | 0     | 0 | 0                        | 1    | 0     | 0 | 0                        | 0    | 0     | 0 | 0                        | 0    | 0     | 0 | 5     | 50            |
| 2:25 PM                         | 0                        | 2    | 0     | 0 | 0                        | 0    | 0     | 0 | 0                        | 0    | 0     | 0 | 0                        | 0    | 0     | 0 | 2     | 50            |
| 2:30 PM                         | 1                        | 0    | 0     | 0 | 0                        | 4    | 1     | 0 | 0                        | 0    | 0     | 0 | 0                        | 0    | 0     | 0 | 6     | 55            |
| 2:35 PM                         | 0                        | 1    | 0     | 0 | 0                        | 1    | 0     | 0 | 0                        | 0    | 0     | 0 | 0                        | 0    | 0     | 0 | 2     | 52            |
| 2:40 PM                         | 0                        | 0    | 0     | 0 | 0                        | 3    | 0     | 0 | 0                        | 0    | 0     | 0 | 0                        | 0    | 0     | 0 | 3     | 51            |
| 2:45 PM                         | 0                        | 2    | 0     | 0 | 0                        | 1    | 0     | 0 | 0                        | 0    | 0     | 1 | 0                        | 0    | 0     | 0 | 4     | 53            |
| 2:50 PM                         | 0                        | 2    | 0     | 0 | 0                        | 0    | 0     | 0 | 0                        | 0    | 0     | 0 | 0                        | 0    | 0     | 0 | 2     | 47            |
| 2:55 PM                         | 1                        | 2    | 0     | 0 | 1                        | 1    | 0     | 0 | 0                        | 0    | 0     | 1 | 0                        | 0    | 0     | 0 | 6     | 47            |
| 3:00 PM                         | 1                        | 1    | 0     | 0 | 0                        | 2    | 1     | 0 | 0                        | 0    | 0     | 1 | 0                        | 1    | 0     | 0 | 7     | 43            |
| 3:05 PM                         | 2                        | 4    | 0     | 0 | 1                        | 2    | 0     | 0 | 0                        | 0    | 0     | 0 | 0                        | 0    | 0     | 0 | 9     | 50            |
| 3:10 PM                         | 1                        | 0    | 0     | 0 | 0                        | 3    | 0     | 0 | 0                        | 0    | 0     | 1 | 0                        | 0    | 0     | 0 | 5     | 52            |
| 3:15 PM                         | 0                        | 1    | 1     | 0 | 0                        | 4    | 0     | 0 | 0                        | 0    | 0     | 0 | 0                        | 1    | 0     | 0 | 7     | 58            |
| 3:20 PM                         | 0                        | 2    | 0     | 0 | 0                        | 0    | 0     | 0 | 0                        | 0    | 0     | 0 | 0                        | 0    | 0     | 0 | 2     | 55            |
| 3:25 PM                         | 1                        | 2    | 0     | 0 | 0                        | 0    | 0     | 0 | 0                        | 0    | 1     | 1 | 0                        | 0    | 0     | 0 | 5     | 58            |
| 3:30 PM                         | 0                        | 1    | 0     | 0 | 0                        | 1    | 0     | 0 | 0                        | 0    | 0     | 2 | 0                        | 0    | 0     | 0 | 4     | 56            |
| 3:35 PM                         | 2                        | 1    | 1     | 0 | 0                        | 1    | 0     | 0 | 0                        | 0    | 0     | 0 | 0                        | 1    | 0     | 0 | 6     | 60            |
| 3:40 PM                         | 0                        | 2    | 0     | 0 | 1                        | 1    | 0     | 0 | 0                        | 0    | 0     | 1 | 0                        | 0    | 0     | 0 | 5     | 62            |
| 3:45 PM                         | 0                        | 2    | 0     | 0 | 0                        | 3    | 0     | 0 | 0                        | 0    | 0     | 1 | 0                        | 0    | 0     | 0 | 6     | 64            |
| 3:50 PM                         | 1                        | 3    | 0     | 0 | 0                        | 2    | 0     | 0 | 0                        | 0    | 0     | 0 | 0                        | 1    | 0     | 0 | 7     | 69            |
| 3:55 PM                         | 2                        | 2    | 0     | 0 | 0                        | 0    | 0     | 0 | 0                        | 0    | 0     | 2 | 0                        | 1    | 0     | 0 | 7     | 70            |
| 4:00 PM                         | 0                        | 3    | 0     | 0 | 0                        | 0    | 0     | 0 | 0                        | 0    | 0     | 2 | 0                        | 0    | 0     | 0 | 5     | 68            |
| 4:05 PM                         | 0                        | 2    | 0     | 0 | 0                        | 1    | 0     | 0 | 0                        | 0    | 0     | 0 | 0                        | 0    | 0     | 0 | 3     | 62            |
| 4:10 PM                         | 1                        | 1    | 0     | 0 | 0                        | 2    | 0     | 0 | 0                        | 0    | 0     | 0 | 0                        | 0    | 0     | 0 | 4     | 61            |
| 4:15 PM                         | 0                        | 1    | 0     | 0 | 0                        | 1    | 0     | 0 | 0                        | 0    | 0     | 0 | 0                        | 0    | 0     | 0 | 2     | 56            |
| 4:20 PM                         | 1                        | 1    | 0     | 0 | 0                        | 1    | 0     | 0 | 0                        | 0    | 0     | 0 | 0                        | 0    | 0     | 0 | 3     | 57            |
| 4:25 PM                         | 0                        | 1    | 1     | 0 | 0                        | 3    | 0     | 0 | 0                        | 0    | 0     | 0 | 0                        | 0    | 0     | 0 | 5     | 57            |
| 4:30 PM                         | 0                        | 3    | 0     | 0 | 0                        | 2    | 0     | 0 | 0                        | 0    | 0     | 2 | 0                        | 0    | 0     | 0 | 7     | 60            |

**Attachment B**

| 5-Min Count Period Beginning At | Kootenay Dr (Northbound) |      |       |   | Kootenay Dr (Southbound) |      |       |   | Oak Ridge Dr (Eastbound) |      |       |    | Oak Ridge Dr (Westbound) |      |       |   | Total | Hourly Totals |
|---------------------------------|--------------------------|------|-------|---|--------------------------|------|-------|---|--------------------------|------|-------|----|--------------------------|------|-------|---|-------|---------------|
|                                 | Left                     | Thru | Right | U | Left                     | Thru | Right | U | Left                     | Thru | Right | U  | Left                     | Thru | Right | U |       |               |
| 4:35 PM                         | 1                        | 2    | 0     | 0 | 0                        | 0    | 0     | 0 | 0                        | 0    | 0     | 0  | 0                        | 0    | 0     | 0 | 3     | 57            |
| 4:40 PM                         | 1                        | 0    | 0     | 0 | 0                        | 0    | 0     | 0 | 0                        | 0    | 2     | 0  | 0                        | 0    | 0     | 0 | 3     | 55            |
| 4:45 PM                         | 0                        | 0    | 0     | 0 | 0                        | 1    | 0     | 0 | 0                        | 0    | 0     | 0  | 0                        | 0    | 0     | 0 | 1     | 50            |
| 4:50 PM                         | 0                        | 0    | 1     | 0 | 1                        | 1    | 0     | 0 | 0                        | 0    | 0     | 0  | 1                        | 0    | 0     | 0 | 4     | 47            |
| 4:55 PM                         | 2                        | 1    | 0     | 0 | 0                        | 1    | 0     | 0 | 0                        | 0    | 0     | 1  | 0                        | 0    | 0     | 0 | 6     | 46            |
| 5:00 PM                         | 2                        | 1    | 0     | 0 | 0                        | 1    | 0     | 0 | 0                        | 0    | 0     | 0  | 0                        | 0    | 0     | 0 | 4     | 45            |
| 5:05 PM                         | 0                        | 4    | 1     | 0 | 0                        | 0    | 0     | 0 | 0                        | 0    | 0     | 1  | 0                        | 0    | 0     | 0 | 6     | 48            |
| 5:10 PM                         | 1                        | 2    | 0     | 0 | 0                        | 0    | 0     | 0 | 0                        | 0    | 0     | 1  | 0                        | 0    | 0     | 0 | 4     | 48            |
| 5:15 PM                         | 0                        | 2    | 0     | 0 | 0                        | 1    | 0     | 0 | 0                        | 0    | 0     | 1  | 0                        | 0    | 0     | 0 | 4     | 50            |
| 5:20 PM                         | 1                        | 0    | 0     | 0 | 0                        | 5    | 0     | 0 | 0                        | 0    | 0     | 1  | 0                        | 0    | 0     | 0 | 7     | 54            |
| 5:25 PM                         | 0                        | 4    | 1     | 0 | 0                        | 0    | 0     | 0 | 0                        | 0    | 0     | 0  | 0                        | 0    | 0     | 0 | 5     | 54            |
| 5:30 PM                         | 0                        | 0    | 0     | 0 | 0                        | 0    | 0     | 0 | 0                        | 0    | 1     | 2  | 0                        | 0    | 0     | 0 | 3     | 50            |
| 5:35 PM                         | 1                        | 1    | 0     | 0 | 0                        | 2    | 0     | 0 | 0                        | 0    | 0     | 1  | 0                        | 0    | 0     | 0 | 5     | 52            |
| 5:40 PM                         | 1                        | 2    | 0     | 0 | 0                        | 0    | 0     | 0 | 0                        | 0    | 0     | 0  | 0                        | 1    | 0     | 0 | 4     | 53            |
| 5:45 PM                         | 4                        | 0    | 0     | 0 | 0                        | 0    | 0     | 0 | 0                        | 0    | 0     | 0  | 0                        | 0    | 0     | 0 | 4     | 56            |
| 5:50 PM                         | 0                        | 2    | 0     | 0 | 0                        | 3    | 0     | 0 | 0                        | 0    | 0     | 1  | 0                        | 0    | 0     | 0 | 6     | 58            |
| 5:55 PM                         | 0                        | 1    | 1     | 0 | 0                        | 1    | 0     | 0 | 0                        | 0    | 0     | 0  | 0                        | 0    | 0     | 0 | 3     | 55            |
| 6:00 PM                         | 1                        | 1    | 0     | 0 | 0                        | 1    | 0     | 0 | 0                        | 0    | 0     | 0  | 0                        | 0    | 0     | 0 | 3     | 54            |
| 6:05 PM                         | 0                        | 0    | 0     | 0 | 0                        | 1    | 0     | 0 | 0                        | 0    | 0     | 0  | 0                        | 0    | 0     | 0 | 1     | 49            |
| 6:10 PM                         | 0                        | 4    | 1     | 0 | 0                        | 0    | 0     | 0 | 0                        | 0    | 0     | 2  | 0                        | 0    | 0     | 0 | 7     | 52            |
| 6:15 PM                         | 0                        | 2    | 0     | 0 | 0                        | 1    | 0     | 0 | 0                        | 0    | 0     | 0  | 0                        | 0    | 0     | 0 | 3     | 51            |
| 6:20 PM                         | 0                        | 1    | 0     | 0 | 0                        | 1    | 0     | 0 | 0                        | 0    | 0     | 1  | 0                        | 0    | 0     | 0 | 3     | 47            |
| 6:25 PM                         | 1                        | 0    | 0     | 0 | 0                        | 2    | 0     | 0 | 0                        | 0    | 0     | 0  | 0                        | 0    | 0     | 0 | 3     | 45            |
| 6:30 PM                         | 0                        | 1    | 0     | 0 | 0                        | 2    | 0     | 0 | 0                        | 0    | 0     | 0  | 0                        | 0    | 0     | 0 | 3     | 45            |
| 6:35 PM                         | 1                        | 3    | 0     | 0 | 0                        | 0    | 0     | 0 | 0                        | 0    | 0     | 0  | 0                        | 0    | 0     | 0 | 4     | 44            |
| 6:40 PM                         | 0                        | 1    | 0     | 0 | 0                        | 0    | 0     | 0 | 0                        | 0    | 0     | 0  | 0                        | 0    | 0     | 0 | 1     | 41            |
| 6:45 PM                         | 0                        | 4    | 0     | 0 | 0                        | 0    | 0     | 0 | 0                        | 0    | 0     | 0  | 0                        | 0    | 0     | 0 | 4     | 41            |
| 6:50 PM                         | 0                        | 2    | 0     | 0 | 0                        | 0    | 0     | 0 | 0                        | 0    | 0     | 2  | 0                        | 0    | 0     | 0 | 4     | 39            |
| 6:55 PM                         | 1                        | 2    | 2     | 0 | 1                        | 2    | 0     | 0 | 0                        | 0    | 0     | 0  | 0                        | 1    | 0     | 0 | 9     | 45            |
| 7:00 PM                         | 0                        | 2    | 2     | 0 | 0                        | 0    | 0     | 0 | 0                        | 0    | 0     | 0  | 0                        | 1    | 0     | 0 | 5     | 47            |
| 7:05 PM                         | 0                        | 1    | 0     | 0 | 0                        | 1    | 0     | 0 | 0                        | 0    | 0     | 0  | 0                        | 0    | 0     | 0 | 2     | 48            |
| 7:10 PM                         | 1                        | 1    | 1     | 0 | 0                        | 0    | 0     | 0 | 0                        | 0    | 0     | 0  | 0                        | 2    | 0     | 0 | 5     | 46            |
| 7:15 PM                         | 0                        | 0    | 0     | 0 | 0                        | 0    | 0     | 0 | 0                        | 0    | 0     | 0  | 0                        | 0    | 0     | 0 | 0     | 43            |
| 7:20 PM                         | 0                        | 3    | 0     | 0 | 0                        | 0    | 0     | 0 | 0                        | 0    | 0     | 0  | 0                        | 0    | 0     | 0 | 3     | 43            |
| 7:25 PM                         | 0                        | 1    | 0     | 0 | 0                        | 1    | 0     | 0 | 0                        | 0    | 0     | 0  | 0                        | 0    | 0     | 0 | 2     | 42            |
| 7:30 PM                         | 0                        | 1    | 0     | 0 | 0                        | 0    | 0     | 0 | 0                        | 0    | 0     | 0  | 0                        | 0    | 0     | 0 | 1     | 40            |
| 7:35 PM                         | 1                        | 0    | 0     | 0 | 0                        | 0    | 0     | 0 | 0                        | 0    | 0     | 1  | 0                        | 0    | 0     | 0 | 2     | 38            |
| 7:40 PM                         | 0                        | 0    | 0     | 0 | 0                        | 1    | 0     | 0 | 0                        | 0    | 0     | 0  | 0                        | 0    | 0     | 0 | 1     | 38            |
| 7:45 PM                         | 1                        | 1    | 0     | 0 | 0                        | 0    | 0     | 0 | 0                        | 0    | 0     | 0  | 0                        | 0    | 0     | 0 | 2     | 36            |
| 7:50 PM                         | 1                        | 0    | 0     | 0 | 0                        | 0    | 0     | 0 | 0                        | 0    | 0     | 1  | 0                        | 0    | 0     | 0 | 2     | 34            |
| 7:55 PM                         | 1                        | 0    | 0     | 0 | 0                        | 0    | 0     | 0 | 0                        | 0    | 0     | 0  | 0                        | 0    | 0     | 0 | 1     | 26            |
| 8:00 PM                         | 0                        | 0    | 0     | 0 | 0                        | 0    | 0     | 0 | 0                        | 0    | 0     | 1  | 0                        | 0    | 0     | 0 | 1     | 22            |
| 8:05 PM                         | 1                        | 2    | 0     | 0 | 0                        | 0    | 0     | 0 | 0                        | 0    | 0     | 0  | 0                        | 0    | 0     | 0 | 3     | 23            |
| 8:10 PM                         | 0                        | 0    | 0     | 0 | 0                        | 0    | 0     | 0 | 0                        | 0    | 0     | 0  | 0                        | 0    | 0     | 0 | 0     | 18            |
| 8:15 PM                         | 1                        | 3    | 1     | 0 | 0                        | 0    | 0     | 0 | 0                        | 0    | 0     | 0  | 0                        | 0    | 0     | 0 | 5     | 23            |
| 8:20 PM                         | 0                        | 1    | 0     | 0 | 0                        | 0    | 0     | 0 | 0                        | 0    | 0     | 0  | 0                        | 0    | 0     | 0 | 1     | 21            |
| 8:25 PM                         | 0                        | 1    | 0     | 0 | 0                        | 0    | 0     | 0 | 0                        | 0    | 0     | 1  | 0                        | 0    | 0     | 0 | 2     | 21            |
| 8:30 PM                         | 1                        | 1    | 0     | 0 | 0                        | 0    | 0     | 0 | 0                        | 0    | 0     | 0  | 0                        | 0    | 0     | 0 | 2     | 22            |
| 8:35 PM                         | 1                        | 1    | 0     | 0 | 0                        | 0    | 0     | 0 | 0                        | 0    | 0     | 0  | 0                        | 0    | 0     | 0 | 2     | 22            |
| 8:40 PM                         | 1                        | 0    | 0     | 0 | 0                        | 0    | 0     | 0 | 0                        | 0    | 0     | 0  | 0                        | 0    | 0     | 0 | 1     | 22            |
| 8:45 PM                         | 0                        | 3    | 0     | 0 | 0                        | 0    | 0     | 0 | 0                        | 0    | 0     | 0  | 0                        | 0    | 0     | 0 | 3     | 23            |
| 8:50 PM                         | 0                        | 1    | 0     | 0 | 0                        | 0    | 0     | 0 | 0                        | 0    | 0     | 0  | 0                        | 0    | 0     | 0 | 1     | 22            |
| 8:55 PM                         | 2                        | 1    | 0     | 0 | 0                        | 1    | 0     | 0 | 0                        | 0    | 0     | 0  | 0                        | 0    | 0     | 0 | 4     | 25            |
| 9:00 PM                         | 0                        | 1    | 2     | 0 | 0                        | 0    | 0     | 0 | 0                        | 0    | 0     | 0  | 0                        | 0    | 0     | 0 | 3     | 27            |
| 9:05 PM                         | 0                        | 1    | 0     | 0 | 0                        | 0    | 0     | 0 | 0                        | 0    | 0     | 0  | 0                        | 0    | 0     | 0 | 1     | 25            |
| 9:10 PM                         | 0                        | 0    | 0     | 0 | 0                        | 1    | 0     | 0 | 0                        | 0    | 0     | 0  | 0                        | 0    | 0     | 0 | 1     | 26            |
| 9:15 PM                         | 0                        | 0    | 0     | 0 | 0                        | 1    | 0     | 0 | 0                        | 0    | 0     | 0  | 0                        | 0    | 0     | 0 | 1     | 22            |
| 9:20 PM                         | 0                        | 1    | 0     | 0 | 0                        | 0    | 0     | 0 | 0                        | 0    | 0     | 0  | 0                        | 0    | 0     | 0 | 1     | 22            |
| 9:25 PM                         | 0                        | 1    | 0     | 0 | 0                        | 0    | 0     | 0 | 0                        | 0    | 0     | 0  | 0                        | 0    | 0     | 0 | 1     | 21            |
| 9:30 PM                         | 0                        | 0    | 0     | 0 | 0                        | 0    | 0     | 0 | 0                        | 0    | 0     | 0  | 0                        | 0    | 0     | 0 | 0     | 19            |
| 9:35 PM                         | 0                        | 0    | 0     | 0 | 0                        | 0    | 0     | 0 | 0                        | 0    | 0     | 0  | 0                        | 0    | 0     | 0 | 0     | 17            |
| 9:40 PM                         | 0                        | 0    | 0     | 0 | 0                        | 2    | 0     | 0 | 0                        | 0    | 0     | 0  | 0                        | 0    | 0     | 0 | 2     | 18            |
| 9:45 PM                         | 2                        | 0    | 0     | 0 | 0                        | 0    | 0     | 0 | 0                        | 0    | 0     | 0  | 0                        | 0    | 0     | 0 | 2     | 17            |
| 9:50 PM                         | 0                        | 0    | 0     | 0 | 0                        | 0    | 0     | 0 | 0                        | 0    | 0     | 0  | 0                        | 0    | 0     | 0 | 0     | 16            |
| 9:55 PM                         | 0                        | 1    | 0     | 0 | 0                        | 0    | 0     | 0 | 0                        | 0    | 0     | 0  | 0                        | 0    | 0     | 0 | 1     | 13            |
| Peak 15-Min Flowrates           | Northbound               |      |       |   | Southbound               |      |       |   | Eastbound                |      |       |    | Westbound                |      |       |   | Total |               |
|                                 | Left                     | Thru | Right | U | Left                     | Thru | Right | U | Left                     | Thru | Right | U  | Left                     | Thru | Right | U |       |               |
| All Vehicles                    | 0                        | 56   | 0     | 0 | 0                        | 108  | 0     | 0 | 0                        | 0    | 0     | 12 | 0                        | 8    | 0     | 0 | 0     | 184           |
| Heavy Trucks                    | 0                        | 0    | 0     | 0 | 0                        | 0    | 0     | 0 | 0                        | 0    | 0     | 0  | 0                        | 0    | 0     | 0 | 0     | 0             |
| Buses                           |                          | 0    |       |   |                          | 0    |       |   |                          |      | 4     |    |                          |      | 0     |   |       | 4             |
| Pedestrians                     | 0                        | 0    | 0     |   | 0                        | 4    | 0     |   | 0                        | 0    | 0     |    | 0                        | 0    | 0     |   |       | 4             |
| Bicycles                        |                          |      |       |   |                          |      |       |   |                          |      |       |    |                          |      |       |   |       |               |
| Scoters                         |                          |      |       |   |                          |      |       |   |                          |      |       |    |                          |      |       |   |       |               |

*Comments:*

LOCATION: Dunas Rd -- Casselle Ave  
 CITY/STATE: Orange, CA

QC JOB #: 16966447  
 DATE: Thu, Apr 10 2025

Peak-Hour: 5:00 PM -- 6:00 PM  
 Peak 15-Min: 5:20 PM -- 5:35 PM

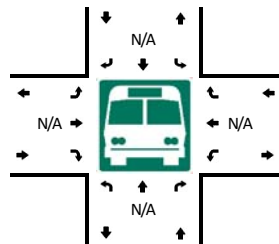
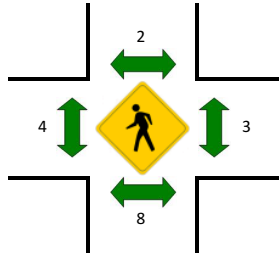
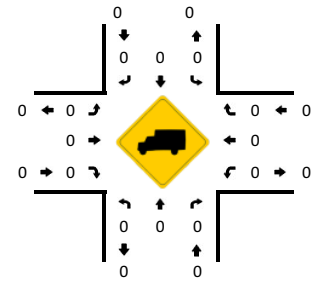
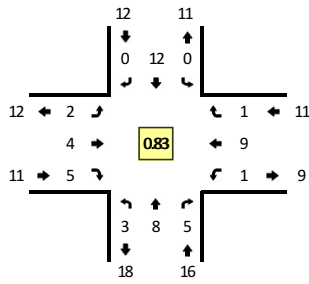

| 5-Min Count Period Beginning At | Dunas Rd (Northbound) |      |       |   | Dunas Rd (Southbound) |      |       |   | Casselle Ave (Eastbound) |      |       |   | Casselle Ave (Westbound) |      |       |   | Total | Hourly Totals |
|---------------------------------|-----------------------|------|-------|---|-----------------------|------|-------|---|--------------------------|------|-------|---|--------------------------|------|-------|---|-------|---------------|
|                                 | Left                  | Thru | Right | U | Left                  | Thru | Right | U | Left                     | Thru | Right | U | Left                     | Thru | Right | U |       |               |
| 6:00 AM                         | 1                     | 0    | 0     | 0 | 0                     | 0    | 0     | 0 | 0                        | 0    | 0     | 0 | 1                        | 0    | 0     | 0 | 2     |               |
| 6:05 AM                         | 0                     | 0    | 0     | 0 | 0                     | 0    | 0     | 0 | 0                        | 0    | 0     | 0 | 0                        | 0    | 0     | 0 | 0     |               |
| 6:10 AM                         | 0                     | 0    | 0     | 0 | 0                     | 0    | 0     | 0 | 0                        | 0    | 0     | 0 | 0                        | 0    | 0     | 0 | 0     |               |
| 6:15 AM                         | 0                     | 0    | 0     | 0 | 0                     | 0    | 0     | 0 | 0                        | 0    | 0     | 0 | 0                        | 2    | 0     | 0 | 2     |               |
| 6:20 AM                         | 0                     | 0    | 0     | 0 | 0                     | 0    | 0     | 0 | 0                        | 0    | 0     | 0 | 0                        | 1    | 0     | 0 | 1     |               |
| 6:25 AM                         | 0                     | 0    | 0     | 0 | 0                     | 2    | 0     | 0 | 0                        | 0    | 0     | 0 | 0                        | 1    | 0     | 0 | 3     |               |
| 6:30 AM                         | 1                     | 0    | 0     | 0 | 0                     | 0    | 0     | 0 | 0                        | 0    | 0     | 0 | 0                        | 0    | 0     | 0 | 1     |               |
| 6:35 AM                         | 0                     | 0    | 0     | 0 | 0                     | 0    | 0     | 0 | 0                        | 0    | 0     | 0 | 0                        | 0    | 0     | 0 | 0     |               |
| 6:40 AM                         | 0                     | 0    | 0     | 0 | 0                     | 0    | 0     | 0 | 0                        | 0    | 0     | 1 | 0                        | 1    | 0     | 0 | 2     |               |
| 6:45 AM                         | 0                     | 1    | 0     | 0 | 0                     | 0    | 0     | 0 | 0                        | 0    | 0     | 0 | 0                        | 0    | 0     | 0 | 1     |               |
| 6:50 AM                         | 1                     | 0    | 0     | 0 | 0                     | 0    | 0     | 0 | 0                        | 0    | 0     | 0 | 0                        | 0    | 0     | 0 | 1     |               |
| 6:55 AM                         | 0                     | 0    | 0     | 0 | 0                     | 1    | 0     | 0 | 0                        | 0    | 0     | 0 | 1                        | 0    | 0     | 0 | 2     | 15            |
| 7:00 AM                         | 0                     | 0    | 0     | 0 | 0                     | 0    | 0     | 0 | 0                        | 0    | 0     | 0 | 0                        | 0    | 0     | 0 | 0     | 13            |
| 7:05 AM                         | 0                     | 0    | 0     | 0 | 0                     | 0    | 0     | 0 | 0                        | 0    | 0     | 0 | 0                        | 1    | 0     | 0 | 1     | 14            |
| 7:10 AM                         | 0                     | 0    | 0     | 0 | 0                     | 0    | 2     | 0 | 0                        | 0    | 0     | 0 | 0                        | 0    | 1     | 0 | 2     | 16            |
| 7:15 AM                         | 0                     | 0    | 0     | 0 | 2                     | 0    | 0     | 0 | 0                        | 0    | 0     | 0 | 0                        | 0    | 1     | 0 | 3     | 17            |
| 7:20 AM                         | 1                     | 0    | 0     | 0 | 0                     | 0    | 0     | 0 | 0                        | 0    | 1     | 1 | 0                        | 0    | 0     | 0 | 3     | 19            |
| 7:25 AM                         | 0                     | 1    | 0     | 0 | 0                     | 0    | 0     | 0 | 0                        | 0    | 0     | 0 | 0                        | 0    | 0     | 0 | 1     | 17            |
| 7:30 AM                         | 0                     | 0    | 1     | 0 | 0                     | 1    | 0     | 0 | 0                        | 0    | 0     | 0 | 0                        | 0    | 0     | 0 | 2     | 18            |
| 7:35 AM                         | 1                     | 0    | 0     | 0 | 0                     | 0    | 0     | 0 | 0                        | 0    | 0     | 0 | 1                        | 1    | 0     | 0 | 3     | 21            |
| 7:40 AM                         | 1                     | 0    | 0     | 0 | 0                     | 0    | 0     | 0 | 0                        | 0    | 2     | 0 | 1                        | 0    | 0     | 0 | 4     | 23            |
| 7:45 AM                         | 3                     | 0    | 0     | 0 | 0                     | 2    | 0     | 0 | 0                        | 0    | 2     | 0 | 1                        | 0    | 2     | 0 | 10    | 32            |
| 7:50 AM                         | 0                     | 0    | 0     | 0 | 0                     | 0    | 0     | 0 | 0                        | 0    | 0     | 0 | 0                        | 2    | 0     | 0 | 2     | 33            |
| 7:55 AM                         | 0                     | 2    | 0     | 0 | 0                     | 1    | 0     | 0 | 0                        | 0    | 0     | 0 | 1                        | 0    | 0     | 0 | 4     | 35            |
| 8:00 AM                         | 0                     | 0    | 0     | 0 | 0                     | 1    | 0     | 0 | 0                        | 0    | 0     | 0 | 0                        | 1    | 0     | 0 | 2     | 37            |
| 8:05 AM                         | 0                     | 0    | 0     | 0 | 0                     | 1    | 0     | 0 | 0                        | 0    | 0     | 0 | 0                        | 0    | 0     | 0 | 1     | 37            |
| 8:10 AM                         | 0                     | 0    | 1     | 0 | 0                     | 3    | 0     | 0 | 0                        | 0    | 0     | 0 | 0                        | 0    | 0     | 0 | 4     | 39            |
| 8:15 AM                         | 0                     | 1    | 0     | 0 | 0                     | 1    | 0     | 0 | 0                        | 0    | 0     | 0 | 0                        | 1    | 0     | 0 | 3     | 39            |
| 8:20 AM                         | 1                     | 2    | 0     | 0 | 0                     | 2    | 0     | 0 | 0                        | 0    | 0     | 0 | 1                        | 0    | 0     | 0 | 6     | 42            |
| 8:25 AM                         | 1                     | 0    | 0     | 0 | 0                     | 0    | 0     | 0 | 0                        | 0    | 0     | 0 | 0                        | 0    | 0     | 0 | 1     | 42            |
| 8:30 AM                         | 0                     | 3    | 0     | 0 | 0                     | 0    | 0     | 0 | 0                        | 0    | 0     | 0 | 1                        | 1    | 0     | 0 | 5     | 45            |
| 8:35 AM                         | 1                     | 0    | 0     | 0 | 0                     | 1    | 0     | 0 | 0                        | 1    | 1     | 0 | 0                        | 0    | 0     | 0 | 4     | 46            |
| 8:40 AM                         | 1                     | 1    | 0     | 0 | 0                     | 0    | 0     | 0 | 0                        | 0    | 0     | 0 | 0                        | 0    | 0     | 0 | 2     | 44            |
| 8:45 AM                         | 0                     | 1    | 0     | 0 | 0                     | 0    | 0     | 0 | 0                        | 0    | 1     | 0 | 0                        | 0    | 0     | 0 | 2     | 36            |
| 8:50 AM                         | 0                     | 0    | 0     | 0 | 0                     | 2    | 0     | 0 | 0                        | 0    | 0     | 0 | 1                        | 0    | 0     | 0 | 3     | 37            |
| 8:55 AM                         | 0                     | 1    | 0     | 0 | 0                     | 0    | 0     | 0 | 0                        | 0    | 0     | 0 | 0                        | 1    | 0     | 0 | 2     | 35            |
| 9:00 AM                         | 0                     | 0    | 0     | 0 | 0                     | 1    | 0     | 0 | 0                        | 0    | 2     | 0 | 0                        | 0    | 0     | 0 | 3     | 36            |
| 9:05 AM                         | 0                     | 0    | 0     | 0 | 0                     | 0    | 0     | 0 | 0                        | 0    | 1     | 0 | 0                        | 2    | 0     | 0 | 3     | 38            |

**Attachment B**

| 5-Min Count Period Beginning At | Dunas Rd (Northbound) |      |       |   | Dunas Rd (Southbound) |      |       |   | Casselle Ave (Eastbound) |      |       |   | Casselle Ave (Westbound) |      |       |   | Total | Hourly Totals |
|---------------------------------|-----------------------|------|-------|---|-----------------------|------|-------|---|--------------------------|------|-------|---|--------------------------|------|-------|---|-------|---------------|
|                                 | Left                  | Thru | Right | U | Left                  | Thru | Right | U | Left                     | Thru | Right | U | Left                     | Thru | Right | U |       |               |
| 9:10 AM                         | 0                     | 0    | 0     | 0 | 0                     | 2    | 0     | 0 | 0                        | 0    | 0     | 0 | 0                        | 0    | 0     | 0 | 2     | 36            |
| 9:15 AM                         | 0                     | 0    | 0     | 0 | 0                     | 0    | 0     | 0 | 0                        | 0    | 0     | 0 | 0                        | 0    | 0     | 0 | 0     | 33            |
| 9:20 AM                         | 0                     | 0    | 0     | 0 | 0                     | 0    | 0     | 0 | 0                        | 0    | 0     | 0 | 0                        | 1    | 1     | 0 | 2     | 29            |
| 9:25 AM                         | 1                     | 1    | 0     | 0 | 0                     | 0    | 0     | 0 | 0                        | 1    | 1     | 0 | 0                        | 1    | 1     | 0 | 6     | 34            |
| 9:30 AM                         | 0                     | 0    | 0     | 0 | 0                     | 1    | 0     | 0 | 0                        | 0    | 0     | 0 | 0                        | 0    | 0     | 0 | 1     | 30            |
| 9:35 AM                         | 0                     | 0    | 0     | 0 | 0                     | 1    | 0     | 0 | 0                        | 0    | 1     | 1 | 0                        | 1    | 0     | 0 | 4     | 30            |
| 9:40 AM                         | 0                     | 0    | 0     | 0 | 0                     | 2    | 0     | 0 | 0                        | 0    | 1     | 0 | 0                        | 0    | 0     | 0 | 3     | 31            |
| 9:45 AM                         | 0                     | 0    | 0     | 0 | 0                     | 0    | 0     | 0 | 0                        | 0    | 1     | 0 | 0                        | 0    | 0     | 0 | 1     | 30            |
| 9:50 AM                         | 0                     | 0    | 0     | 0 | 0                     | 0    | 0     | 0 | 0                        | 0    | 1     | 1 | 0                        | 0    | 1     | 0 | 3     | 30            |
| 9:55 AM                         | 0                     | 1    | 0     | 0 | 0                     | 0    | 0     | 0 | 0                        | 0    | 1     | 0 | 0                        | 0    | 2     | 0 | 4     | 32            |
| 10:00 AM                        | 0                     | 0    | 0     | 0 | 0                     | 0    | 0     | 0 | 0                        | 0    | 0     | 0 | 0                        | 0    | 0     | 0 | 0     | 29            |
| 10:05 AM                        | 0                     | 0    | 0     | 0 | 0                     | 0    | 0     | 0 | 0                        | 0    | 0     | 1 | 0                        | 0    | 0     | 0 | 1     | 27            |
| 10:10 AM                        | 1                     | 0    | 0     | 0 | 0                     | 0    | 0     | 0 | 0                        | 0    | 0     | 0 | 0                        | 0    | 0     | 0 | 1     | 26            |
| 10:15 AM                        | 0                     | 0    | 0     | 0 | 0                     | 0    | 0     | 0 | 0                        | 0    | 0     | 0 | 0                        | 0    | 0     | 0 | 0     | 26            |
| 10:20 AM                        | 1                     | 0    | 0     | 0 | 0                     | 0    | 0     | 0 | 0                        | 0    | 0     | 0 | 0                        | 0    | 0     | 0 | 1     | 25            |
| 10:25 AM                        | 1                     | 0    | 0     | 0 | 0                     | 0    | 0     | 0 | 0                        | 0    | 0     | 0 | 0                        | 1    | 0     | 0 | 2     | 21            |
| 10:30 AM                        | 1                     | 0    | 0     | 0 | 0                     | 0    | 0     | 0 | 0                        | 0    | 0     | 0 | 0                        | 1    | 0     | 0 | 2     | 22            |
| 10:35 AM                        | 0                     | 1    | 0     | 0 | 0                     | 1    | 0     | 0 | 0                        | 0    | 1     | 0 | 0                        | 0    | 0     | 0 | 3     | 21            |
| 10:40 AM                        | 1                     | 0    | 0     | 0 | 0                     | 0    | 0     | 0 | 0                        | 0    | 1     | 0 | 0                        | 0    | 0     | 0 | 2     | 20            |
| 10:45 AM                        | 0                     | 0    | 0     | 0 | 0                     | 0    | 0     | 0 | 0                        | 0    | 0     | 0 | 0                        | 0    | 0     | 0 | 0     | 19            |
| 10:50 AM                        | 1                     | 0    | 0     | 0 | 0                     | 0    | 0     | 0 | 0                        | 0    | 0     | 2 | 0                        | 0    | 0     | 0 | 3     | 19            |
| 10:55 AM                        | 0                     | 0    | 1     | 0 | 0                     | 1    | 0     | 0 | 0                        | 1    | 0     | 0 | 0                        | 0    | 1     | 0 | 4     | 19            |
| 11:00 AM                        | 0                     | 1    | 0     | 0 | 0                     | 0    | 0     | 0 | 0                        | 1    | 0     | 1 | 0                        | 0    | 0     | 0 | 3     | 22            |
| 11:05 AM                        | 0                     | 1    | 2     | 0 | 0                     | 0    | 1     | 0 | 0                        | 0    | 0     | 0 | 0                        | 1    | 0     | 0 | 5     | 26            |
| 11:10 AM                        | 0                     | 2    | 0     | 0 | 0                     | 2    | 0     | 0 | 0                        | 0    | 0     | 0 | 0                        | 0    | 0     | 0 | 4     | 29            |
| 11:15 AM                        | 1                     | 1    | 0     | 0 | 0                     | 0    | 0     | 0 | 0                        | 0    | 1     | 0 | 0                        | 0    | 0     | 0 | 3     | 32            |
| 11:20 AM                        | 0                     | 2    | 0     | 0 | 0                     | 0    | 0     | 0 | 0                        | 0    | 0     | 0 | 0                        | 0    | 0     | 0 | 2     | 33            |
| 11:25 AM                        | 1                     | 0    | 0     | 0 | 0                     | 0    | 1     | 0 | 0                        | 0    | 0     | 0 | 0                        | 1    | 0     | 0 | 3     | 34            |
| 11:30 AM                        | 0                     | 0    | 0     | 0 | 0                     | 0    | 0     | 0 | 0                        | 0    | 1     | 0 | 0                        | 0    | 0     | 0 | 1     | 33            |
| 11:35 AM                        | 0                     | 0    | 0     | 0 | 0                     | 0    | 0     | 0 | 0                        | 0    | 0     | 1 | 0                        | 0    | 0     | 0 | 1     | 31            |
| 11:40 AM                        | 0                     | 1    | 0     | 0 | 0                     | 1    | 0     | 0 | 0                        | 0    | 1     | 1 | 0                        | 0    | 0     | 0 | 4     | 33            |
| 11:45 AM                        | 0                     | 0    | 0     | 0 | 0                     | 1    | 0     | 0 | 0                        | 0    | 0     | 0 | 0                        | 1    | 0     | 0 | 2     | 35            |
| 11:50 AM                        | 0                     | 0    | 0     | 0 | 0                     | 0    | 0     | 0 | 0                        | 0    | 0     | 0 | 0                        | 0    | 0     | 0 | 0     | 32            |
| 11:55 AM                        | 0                     | 0    | 0     | 0 | 0                     | 1    | 1     | 0 | 0                        | 0    | 0     | 0 | 0                        | 0    | 2     | 0 | 4     | 32            |
| 12:00 PM                        | 0                     | 1    | 0     | 0 | 0                     | 1    | 0     | 0 | 0                        | 0    | 0     | 1 | 0                        | 0    | 0     | 0 | 3     | 32            |
| 12:05 PM                        | 0                     | 0    | 0     | 0 | 0                     | 1    | 0     | 0 | 0                        | 0    | 0     | 0 | 0                        | 0    | 0     | 0 | 1     | 28            |
| 12:10 PM                        | 0                     | 1    | 0     | 0 | 0                     | 0    | 0     | 0 | 0                        | 0    | 1     | 0 | 0                        | 0    | 1     | 0 | 3     | 27            |
| 12:15 PM                        | 0                     | 0    | 1     | 0 | 0                     | 2    | 1     | 0 | 0                        | 0    | 0     | 0 | 0                        | 0    | 2     | 0 | 6     | 30            |
| 12:20 PM                        | 0                     | 0    | 0     | 0 | 0                     | 0    | 0     | 0 | 0                        | 0    | 0     | 1 | 0                        | 0    | 0     | 0 | 1     | 29            |
| 12:25 PM                        | 1                     | 0    | 0     | 0 | 0                     | 1    | 0     | 0 | 0                        | 0    | 1     | 1 | 0                        | 1    | 0     | 0 | 5     | 31            |
| 12:30 PM                        | 0                     | 3    | 1     | 0 | 0                     | 0    | 0     | 0 | 0                        | 0    | 1     | 1 | 0                        | 0    | 0     | 0 | 6     | 36            |
| 12:35 PM                        | 0                     | 4    | 0     | 0 | 0                     | 0    | 0     | 0 | 0                        | 0    | 0     | 0 | 0                        | 0    | 0     | 0 | 4     | 39            |
| 12:40 PM                        | 0                     | 1    | 0     | 0 | 0                     | 1    | 0     | 0 | 0                        | 1    | 0     | 0 | 0                        | 0    | 0     | 0 | 3     | 38            |
| 12:45 PM                        | 0                     | 0    | 0     | 0 | 0                     | 1    | 0     | 0 | 0                        | 1    | 0     | 0 | 0                        | 0    | 0     | 0 | 2     | 38            |
| 12:50 PM                        | 0                     | 1    | 0     | 0 | 0                     | 1    | 0     | 0 | 0                        | 0    | 0     | 0 | 0                        | 1    | 0     | 0 | 3     | 41            |
| 12:55 PM                        | 0                     | 0    | 0     | 0 | 0                     | 1    | 0     | 0 | 0                        | 0    | 0     | 0 | 0                        | 0    | 0     | 0 | 1     | 38            |
| 1:00 PM                         | 0                     | 0    | 0     | 0 | 0                     | 1    | 0     | 0 | 0                        | 0    | 1     | 0 | 0                        | 0    | 0     | 0 | 2     | 37            |
| 1:05 PM                         | 0                     | 1    | 0     | 0 | 0                     | 0    | 0     | 0 | 0                        | 0    | 0     | 1 | 0                        | 0    | 0     | 0 | 2     | 38            |
| 1:10 PM                         | 0                     | 0    | 0     | 0 | 0                     | 1    | 0     | 0 | 0                        | 0    | 0     | 0 | 0                        | 0    | 2     | 0 | 3     | 38            |
| 1:15 PM                         | 0                     | 0    | 0     | 0 | 0                     | 0    | 0     | 0 | 0                        | 0    | 0     | 0 | 0                        | 0    | 3     | 0 | 3     | 35            |
| 1:20 PM                         | 0                     | 1    | 0     | 0 | 0                     | 1    | 0     | 0 | 0                        | 0    | 1     | 1 | 0                        | 0    | 0     | 0 | 4     | 38            |
| 1:25 PM                         | 0                     | 0    | 0     | 0 | 0                     | 0    | 0     | 0 | 0                        | 0    | 0     | 0 | 0                        | 0    | 0     | 0 | 0     | 33            |
| 1:30 PM                         | 0                     | 0    | 0     | 0 | 0                     | 0    | 0     | 0 | 0                        | 0    | 0     | 0 | 0                        | 0    | 0     | 0 | 0     | 27            |
| 1:35 PM                         | 0                     | 0    | 1     | 0 | 0                     | 2    | 0     | 0 | 0                        | 0    | 0     | 0 | 0                        | 0    | 0     | 0 | 3     | 26            |
| 1:40 PM                         | 1                     | 0    | 0     | 0 | 0                     | 0    | 0     | 0 | 0                        | 0    | 0     | 0 | 0                        | 0    | 0     | 0 | 1     | 24            |
| 1:45 PM                         | 0                     | 0    | 1     | 0 | 0                     | 1    | 0     | 0 | 0                        | 0    | 0     | 1 | 0                        | 0    | 0     | 0 | 3     | 25            |
| 1:50 PM                         | 0                     | 1    | 2     | 0 | 0                     | 0    | 0     | 0 | 0                        | 0    | 1     | 0 | 0                        | 0    | 0     | 0 | 4     | 26            |
| 1:55 PM                         | 1                     | 1    | 0     | 0 | 0                     | 0    | 0     | 0 | 0                        | 0    | 0     | 0 | 0                        | 0    | 0     | 0 | 2     | 27            |
| 2:00 PM                         | 0                     | 2    | 1     | 0 | 0                     | 0    | 0     | 0 | 0                        | 0    | 0     | 0 | 0                        | 0    | 0     | 0 | 3     | 28            |
| 2:05 PM                         | 0                     | 0    | 1     | 0 | 0                     | 0    | 0     | 0 | 0                        | 0    | 0     | 0 | 0                        | 0    | 2     | 0 | 3     | 29            |
| 2:10 PM                         | 0                     | 0    | 0     | 0 | 0                     | 0    | 0     | 0 | 0                        | 0    | 0     | 1 | 0                        | 0    | 1     | 0 | 3     | 29            |
| 2:15 PM                         | 0                     | 0    | 1     | 0 | 0                     | 0    | 0     | 0 | 0                        | 0    | 1     | 0 | 0                        | 0    | 0     | 0 | 2     | 28            |
| 2:20 PM                         | 0                     | 1    | 0     | 0 | 0                     | 0    | 0     | 0 | 0                        | 0    | 0     | 1 | 0                        | 0    | 1     | 0 | 3     | 27            |
| 2:25 PM                         | 0                     | 0    | 0     | 0 | 0                     | 1    | 0     | 0 | 0                        | 0    | 2     | 1 | 0                        | 0    | 1     | 0 | 5     | 32            |
| 2:30 PM                         | 0                     | 0    | 0     | 0 | 0                     | 0    | 0     | 0 | 0                        | 0    | 0     | 0 | 0                        | 0    | 0     | 0 | 0     | 32            |
| 2:35 PM                         | 0                     | 1    | 1     | 0 | 0                     | 0    | 0     | 0 | 0                        | 0    | 0     | 0 | 0                        | 0    | 0     | 0 | 2     | 31            |
| 2:40 PM                         | 0                     | 0    | 0     | 0 | 0                     | 1    | 0     | 0 | 0                        | 0    | 1     | 0 | 0                        | 0    | 2     | 0 | 4     | 34            |
| 2:45 PM                         | 0                     | 1    | 0     | 0 | 0                     | 1    | 0     | 0 | 0                        | 0    | 0     | 0 | 0                        | 0    | 0     | 0 | 2     | 33            |
| 2:50 PM                         | 0                     | 1    | 1     | 0 | 0                     | 1    | 0     | 0 | 0                        | 0    | 0     | 0 | 0                        | 0    | 1     | 0 | 4     | 33            |
| 2:55 PM                         | 0                     | 1    | 0     | 0 | 0                     | 2    | 0     | 0 | 0                        | 0    | 0     | 0 | 0                        | 1    | 0     | 0 | 4     | 35            |
| 3:00 PM                         | 2                     | 0    | 0     | 0 | 0                     | 2    | 0     | 0 | 0                        | 0    | 0     | 0 | 0                        | 0    | 0     | 0 | 4     | 36            |
| 3:05 PM                         | 0                     | 2    | 1     | 0 | 0                     | 0    | 0     | 0 | 0                        | 0    | 0     | 0 | 0                        | 0    | 0     | 0 | 3     | 36            |
| 3:10 PM                         | 0                     | 1    | 0     | 0 | 0                     | 0    | 0     | 0 | 0                        | 0    | 1     | 0 | 0                        | 1    | 0     | 0 | 3     | 36            |
| 3:15 PM                         | 0                     | 1    | 0     | 0 | 0                     | 0    | 0     | 0 | 0                        | 0    | 0     | 0 | 0                        | 0    | 0     | 0 | 1     | 35            |
| 3:20 PM                         | 0                     | 0    | 0     | 0 | 0                     | 1    | 0     | 0 | 0                        | 0    | 1     | 1 | 0                        | 0    | 0     | 0 | 3     | 35            |
| 3:25 PM                         | 1                     | 0    | 0     | 0 | 0                     | 1    | 0     | 0 | 0                        | 0    | 0     | 0 | 0                        | 0    | 0     | 0 | 2     | 32            |
| 3:30 PM                         | 0                     | 2    | 1     | 0 | 0                     | 1    | 0     | 0 | 0                        | 0    | 2     | 1 | 0                        | 0    | 0     | 0 | 7     | 39            |
| 3:35 PM                         | 0                     | 1    | 0     | 0 | 0                     | 0    | 0     | 0 | 0                        | 0    | 0     | 0 | 0                        | 0    | 0     | 0 | 1     | 38            |
| 3:40 PM                         | 0                     | 3    | 0     | 0 | 0                     | 1    | 0     | 0 | 0                        | 0    | 1     | 0 | 0                        | 0    | 0     | 0 | 5     | 39            |
| 3:45 PM                         | 0                     | 0    | 0     | 0 | 0                     | 2    | 0     | 0 | 0                        | 0    | 1     | 0 | 0                        | 0    | 0     | 0 | 3     | 40            |
| 3:50 PM                         | 1                     | 1    | 1     | 0 | 0                     | 1    | 0     | 0 | 0                        | 0    | 0     | 0 | 0                        | 0    | 1     | 0 | 5     | 41            |
| 3:55 PM                         | 0                     | 3    | 1     | 0 | 1                     | 1    | 0     | 0 | 0                        | 0    | 0     | 0 | 0                        | 0    | 0     | 0 | 6     | 43            |
| 4:00 PM                         | 0                     | 3    | 1     | 0 | 0                     | 0    | 0     | 0 | 0                        | 0    | 1     | 0 | 0                        | 0    | 1     | 0 | 6     | 45            |
| 4:05 PM                         | 0                     | 0    | 0     | 0 | 0                     | 0    | 0     | 0 | 0                        | 0    | 0     | 1 | 0                        | 0    | 0     | 0 | 2     | 44            |
| 4:10 PM                         | 0                     | 1    | 0     | 0 | 0                     | 0    | 0     | 0 | 0                        | 0    | 0     | 0 | 0                        | 1    | 0     | 1 | 3     | 44            |
| 4:15 PM                         | 0                     | 0    | 0     | 0 | 0                     | 0    | 0     | 0 | 0                        | 0    | 0     | 0 | 0                        | 0    | 0     | 0 | 0     | 43            |
| 4:20 PM                         | 0                     | 2    | 0     | 0 | 0                     | 0    | 0     | 0 | 0                        | 0    | 1     | 1 | 0                        | 0    | 0     | 0 | 4     | 44            |
| 4:25 PM                         | 0                     | 2    | 0     | 0 | 0                     | 0    | 0     | 0 | 0                        | 0    | 1     | 2 | 0                        | 0    | 1     | 0 | 6     | 48            |
| 4:30 PM                         | 1                     | 0    | 0     | 0 | 0                     | 0    | 0     | 0 | 0                        | 0    | 0     | 0 | 0                        | 0    | 0     | 0 | 1     | 42            |

## Attachment B

| 5-Min Count Period Beginning At | Dunas Rd (Northbound) |      |       |   | Dunas Rd (Southbound) |      |       |   | Casselle Ave (Eastbound) |      |       |   | Casselle Ave (Westbound) |      |       |   | Total | Hourly Totals |
|---------------------------------|-----------------------|------|-------|---|-----------------------|------|-------|---|--------------------------|------|-------|---|--------------------------|------|-------|---|-------|---------------|
|                                 | Left                  | Thru | Right | U | Left                  | Thru | Right | U | Left                     | Thru | Right | U | Left                     | Thru | Right | U |       |               |
| 4:35 PM                         | 1                     | 2    | 0     | 0 | 0                     | 1    | 0     | 0 | 0                        | 0    | 1     | 0 | 1                        | 0    | 0     | 0 | 6     | 47            |
| 4:40 PM                         | 1                     | 0    | 0     | 0 | 0                     | 1    | 1     | 0 | 0                        | 0    | 0     | 0 | 0                        | 0    | 0     | 0 | 3     | 45            |
| 4:45 PM                         | 0                     | 2    | 0     | 0 | 0                     | 0    | 0     | 0 | 0                        | 0    | 1     | 0 | 0                        | 0    | 0     | 0 | 3     | 45            |
| 4:50 PM                         | 0                     | 0    | 0     | 0 | 1                     | 1    | 0     | 0 | 0                        | 0    | 0     | 0 | 0                        | 0    | 0     | 0 | 2     | 42            |
| 4:55 PM                         | 0                     | 0    | 0     | 0 | 0                     | 0    | 0     | 0 | 0                        | 0    | 0     | 0 | 1                        | 0    | 0     | 0 | 1     | 37            |
| 5:00 PM                         | 1                     | 0    | 1     | 0 | 0                     | 1    | 0     | 0 | 0                        | 0    | 0     | 2 | 0                        | 2    | 0     | 0 | 7     | 38            |
| 5:05 PM                         | 0                     | 1    | 0     | 0 | 0                     | 0    | 0     | 0 | 0                        | 0    | 0     | 0 | 0                        | 2    | 0     | 0 | 3     | 39            |
| 5:10 PM                         | 0                     | 1    | 1     | 0 | 0                     | 0    | 0     | 0 | 0                        | 1    | 0     | 0 | 0                        | 0    | 0     | 0 | 3     | 39            |
| 5:15 PM                         | 0                     | 0    | 0     | 0 | 0                     | 0    | 0     | 0 | 0                        | 0    | 0     | 0 | 0                        | 1    | 0     | 0 | 1     | 40            |
| 5:20 PM                         | 0                     | 2    | 1     | 0 | 0                     | 0    | 0     | 0 | 0                        | 0    | 1     | 1 | 0                        | 1    | 0     | 0 | 6     | 42            |
| 5:25 PM                         | 0                     | 0    | 0     | 0 | 0                     | 4    | 0     | 0 | 0                        | 0    | 0     | 1 | 0                        | 1    | 0     | 0 | 6     | 42            |
| 5:30 PM                         | 0                     | 0    | 0     | 0 | 0                     | 0    | 0     | 0 | 0                        | 0    | 1     | 0 | 0                        | 2    | 0     | 0 | 3     | 44            |
| 5:35 PM                         | 1                     | 2    | 0     | 0 | 0                     | 1    | 0     | 0 | 0                        | 0    | 1     | 0 | 0                        | 0    | 0     | 0 | 5     | 43            |
| 5:40 PM                         | 0                     | 0    | 1     | 0 | 0                     | 0    | 0     | 0 | 0                        | 0    | 1     | 0 | 0                        | 0    | 0     | 0 | 2     | 42            |
| 5:45 PM                         | 1                     | 0    | 0     | 0 | 0                     | 2    | 0     | 0 | 0                        | 1    | 0     | 0 | 0                        | 0    | 0     | 0 | 4     | 43            |
| 5:50 PM                         | 0                     | 2    | 0     | 0 | 0                     | 0    | 0     | 0 | 0                        | 0    | 0     | 1 | 0                        | 0    | 0     | 0 | 3     | 44            |
| 5:55 PM                         | 0                     | 0    | 1     | 0 | 0                     | 4    | 0     | 0 | 0                        | 0    | 0     | 0 | 0                        | 1    | 1     | 0 | 7     | 50            |
| 6:00 PM                         | 1                     | 0    | 0     | 0 | 0                     | 0    | 0     | 0 | 0                        | 0    | 0     | 0 | 0                        | 0    | 0     | 0 | 1     | 44            |
| 6:05 PM                         | 0                     | 2    | 0     | 0 | 0                     | 0    | 0     | 0 | 0                        | 0    | 0     | 0 | 0                        | 1    | 1     | 0 | 4     | 45            |
| 6:10 PM                         | 1                     | 1    | 1     | 0 | 0                     | 0    | 0     | 0 | 0                        | 0    | 1     | 0 | 0                        | 0    | 0     | 0 | 4     | 46            |
| 6:15 PM                         | 0                     | 0    | 0     | 0 | 0                     | 0    | 0     | 0 | 0                        | 0    | 0     | 0 | 0                        | 0    | 0     | 0 | 0     | 45            |
| 6:20 PM                         | 0                     | 0    | 0     | 0 | 0                     | 1    | 2     | 0 | 0                        | 0    | 1     | 0 | 0                        | 0    | 1     | 0 | 5     | 44            |
| 6:25 PM                         | 0                     | 1    | 0     | 0 | 0                     | 0    | 0     | 0 | 0                        | 0    | 0     | 0 | 0                        | 1    | 0     | 0 | 2     | 40            |
| 6:30 PM                         | 1                     | 0    | 1     | 0 | 0                     | 0    | 0     | 0 | 0                        | 0    | 2     | 1 | 0                        | 0    | 0     | 0 | 5     | 42            |
| 6:35 PM                         | 0                     | 0    | 0     | 0 | 0                     | 0    | 0     | 0 | 0                        | 0    | 1     | 0 | 0                        | 2    | 0     | 0 | 3     | 40            |
| 6:40 PM                         | 0                     | 2    | 0     | 0 | 0                     | 0    | 1     | 0 | 0                        | 0    | 3     | 0 | 0                        | 0    | 0     | 0 | 6     | 44            |
| 6:45 PM                         | 0                     | 0    | 0     | 0 | 0                     | 0    | 0     | 0 | 0                        | 0    | 0     | 0 | 0                        | 0    | 0     | 0 | 0     | 40            |
| 6:50 PM                         | 0                     | 1    | 0     | 0 | 0                     | 0    | 0     | 0 | 0                        | 0    | 0     | 1 | 0                        | 0    | 0     | 0 | 3     | 40            |
| 6:55 PM                         | 0                     | 1    | 0     | 0 | 0                     | 1    | 0     | 0 | 0                        | 0    | 0     | 0 | 0                        | 0    | 0     | 0 | 2     | 35            |
| 7:00 PM                         | 0                     | 1    | 0     | 0 | 0                     | 0    | 0     | 0 | 0                        | 0    | 0     | 0 | 0                        | 0    | 0     | 0 | 1     | 35            |
| 7:05 PM                         | 0                     | 1    | 0     | 0 | 0                     | 1    | 0     | 0 | 0                        | 0    | 0     | 1 | 0                        | 0    | 0     | 0 | 3     | 34            |
| 7:10 PM                         | 0                     | 0    | 0     | 0 | 0                     | 1    | 0     | 0 | 0                        | 0    | 1     | 1 | 0                        | 0    | 0     | 0 | 3     | 33            |
| 7:15 PM                         | 0                     | 0    | 1     | 0 | 0                     | 1    | 0     | 0 | 0                        | 0    | 0     | 0 | 0                        | 1    | 0     | 0 | 3     | 36            |
| 7:20 PM                         | 0                     | 1    | 0     | 0 | 0                     | 0    | 0     | 0 | 0                        | 0    | 0     | 0 | 0                        | 1    | 0     | 0 | 2     | 33            |
| 7:25 PM                         | 0                     | 0    | 1     | 0 | 0                     | 0    | 0     | 0 | 0                        | 0    | 0     | 0 | 0                        | 1    | 0     | 0 | 2     | 33            |
| 7:30 PM                         | 1                     | 0    | 0     | 0 | 0                     | 0    | 0     | 0 | 0                        | 0    | 0     | 0 | 0                        | 0    | 0     | 0 | 1     | 29            |
| 7:35 PM                         | 0                     | 1    | 0     | 0 | 0                     | 1    | 0     | 0 | 0                        | 0    | 0     | 1 | 0                        | 0    | 0     | 0 | 3     | 29            |
| 7:40 PM                         | 0                     | 0    | 0     | 0 | 0                     | 1    | 0     | 0 | 0                        | 1    | 0     | 0 | 0                        | 0    | 0     | 0 | 2     | 25            |
| 7:45 PM                         | 0                     | 1    | 0     | 0 | 0                     | 0    | 0     | 0 | 0                        | 0    | 0     | 0 | 0                        | 0    | 0     | 0 | 1     | 26            |
| 7:50 PM                         | 0                     | 0    | 0     | 0 | 0                     | 0    | 0     | 0 | 0                        | 0    | 0     | 0 | 0                        | 0    | 0     | 0 | 0     | 23            |
| 7:55 PM                         | 0                     | 0    | 0     | 0 | 0                     | 0    | 0     | 0 | 0                        | 0    | 0     | 0 | 0                        | 0    | 0     | 0 | 0     | 21            |
| 8:00 PM                         | 0                     | 0    | 0     | 0 | 0                     | 1    | 0     | 0 | 0                        | 0    | 1     | 0 | 0                        | 0    | 0     | 0 | 2     | 22            |
| 8:05 PM                         | 0                     | 0    | 1     | 0 | 0                     | 0    | 0     | 0 | 0                        | 0    | 0     | 0 | 0                        | 0    | 0     | 0 | 1     | 20            |
| 8:10 PM                         | 0                     | 1    | 0     | 0 | 0                     | 1    | 0     | 0 | 0                        | 0    | 0     | 0 | 0                        | 0    | 0     | 0 | 2     | 19            |
| 8:15 PM                         | 1                     | 1    | 0     | 0 | 0                     | 1    | 0     | 0 | 0                        | 0    | 0     | 0 | 0                        | 0    | 0     | 0 | 3     | 19            |
| 8:20 PM                         | 0                     | 0    | 0     | 0 | 0                     | 0    | 0     | 0 | 0                        | 0    | 0     | 0 | 0                        | 0    | 0     | 0 | 0     | 17            |
| 8:25 PM                         | 0                     | 0    | 0     | 0 | 0                     | 0    | 0     | 0 | 0                        | 0    | 1     | 0 | 0                        | 0    | 0     | 0 | 1     | 16            |
| 8:30 PM                         | 0                     | 1    | 0     | 0 | 0                     | 0    | 0     | 0 | 0                        | 0    | 0     | 0 | 0                        | 0    | 0     | 0 | 1     | 16            |
| 8:35 PM                         | 0                     | 0    | 0     | 0 | 0                     | 0    | 0     | 0 | 0                        | 0    | 0     | 0 | 0                        | 0    | 0     | 0 | 0     | 13            |
| 8:40 PM                         | 1                     | 0    | 0     | 0 | 0                     | 0    | 0     | 0 | 0                        | 0    | 0     | 1 | 0                        | 1    | 0     | 0 | 3     | 14            |
| 8:45 PM                         | 0                     | 1    | 0     | 0 | 0                     | 0    | 0     | 0 | 0                        | 0    | 0     | 0 | 0                        | 0    | 0     | 0 | 1     | 14            |
| 8:50 PM                         | 0                     | 1    | 0     | 0 | 0                     | 0    | 0     | 0 | 0                        | 0    | 0     | 0 | 0                        | 0    | 0     | 0 | 1     | 15            |
| 8:55 PM                         | 1                     | 0    | 0     | 0 | 0                     | 0    | 0     | 0 | 0                        | 0    | 0     | 0 | 0                        | 0    | 0     | 0 | 1     | 16            |
| 9:00 PM                         | 0                     | 1    | 0     | 0 | 0                     | 0    | 0     | 0 | 0                        | 1    | 0     | 0 | 0                        | 0    | 0     | 0 | 2     | 16            |
| 9:05 PM                         | 0                     | 0    | 0     | 0 | 0                     | 0    | 0     | 0 | 0                        | 0    | 0     | 0 | 0                        | 0    | 0     | 0 | 0     | 15            |
| 9:10 PM                         | 0                     | 0    | 0     | 0 | 0                     | 0    | 0     | 0 | 0                        | 0    | 0     | 1 | 0                        | 0    | 0     | 0 | 1     | 14            |
| 9:15 PM                         | 0                     | 0    | 0     | 0 | 0                     | 0    | 0     | 0 | 0                        | 0    | 0     | 0 | 0                        | 0    | 0     | 0 | 0     | 11            |
| 9:20 PM                         | 0                     | 0    | 0     | 0 | 0                     | 0    | 0     | 0 | 0                        | 0    | 0     | 0 | 0                        | 0    | 0     | 0 | 0     | 11            |
| 9:25 PM                         | 0                     | 0    | 0     | 0 | 0                     | 0    | 0     | 0 | 0                        | 0    | 0     | 0 | 0                        | 1    | 0     | 0 | 1     | 11            |
| 9:30 PM                         | 0                     | 0    | 0     | 0 | 0                     | 0    | 0     | 0 | 0                        | 0    | 0     | 0 | 0                        | 0    | 0     | 0 | 0     | 10            |
| 9:35 PM                         | 0                     | 0    | 0     | 0 | 0                     | 0    | 0     | 0 | 0                        | 0    | 0     | 0 | 0                        | 0    | 0     | 0 | 0     | 10            |
| 9:40 PM                         | 0                     | 0    | 0     | 0 | 0                     | 1    | 0     | 0 | 0                        | 0    | 0     | 0 | 0                        | 0    | 0     | 0 | 1     | 8             |
| 9:45 PM                         | 0                     | 0    | 0     | 0 | 0                     | 0    | 0     | 0 | 0                        | 0    | 0     | 0 | 0                        | 0    | 0     | 0 | 0     | 7             |
| 9:50 PM                         | 0                     | 0    | 0     | 0 | 0                     | 0    | 0     | 0 | 0                        | 0    | 0     | 0 | 0                        | 0    | 0     | 0 | 0     | 6             |
| 9:55 PM                         | 0                     | 0    | 0     | 0 | 0                     | 0    | 0     | 0 | 0                        | 0    | 0     | 0 | 0                        | 1    | 0     | 0 | 1     | 6             |
| Peak 15-Min Flowrates           | Northbound            |      |       |   | Southbound            |      |       |   | Eastbound                |      |       |   | Westbound                |      |       |   | Total |               |
|                                 | Left                  | Thru | Right | U | Left                  | Thru | Right | U | Left                     | Thru | Right | U | Left                     | Thru | Right | U |       |               |
| All Vehicles                    | 0                     | 8    | 4     | 0 | 0                     | 16   | 0     | 0 | 0                        | 8    | 8     | 0 | 4                        | 12   | 0     | 0 | 60    |               |
| Heavy Trucks                    | 0                     | 0    | 0     | 0 | 0                     | 0    | 0     | 0 | 0                        | 0    | 0     | 0 | 0                        | 0    | 0     | 0 | 0     |               |
| Buses                           |                       |      |       |   |                       |      |       |   |                          |      |       |   |                          |      |       |   |       |               |
| Pedestrians                     |                       | 12   |       |   |                       | 0    |       |   |                          | 4    |       |   |                          | 4    |       |   | 20    |               |
| Bicycles                        | 0                     | 0    | 0     |   | 0                     | 0    | 0     |   | 0                        | 0    | 0     |   | 0                        | 0    | 0     |   | 0     |               |
| Scoters                         |                       |      |       |   |                       |      |       |   |                          |      |       |   |                          |      |       |   |       |               |

Comments:

LOCATION: Cottonwood Dr -- Deep Well Rd  
 CITY/STATE: North Tustin, CA

QC JOB #: 16966448  
 DATE: Thu, Apr 10 2025

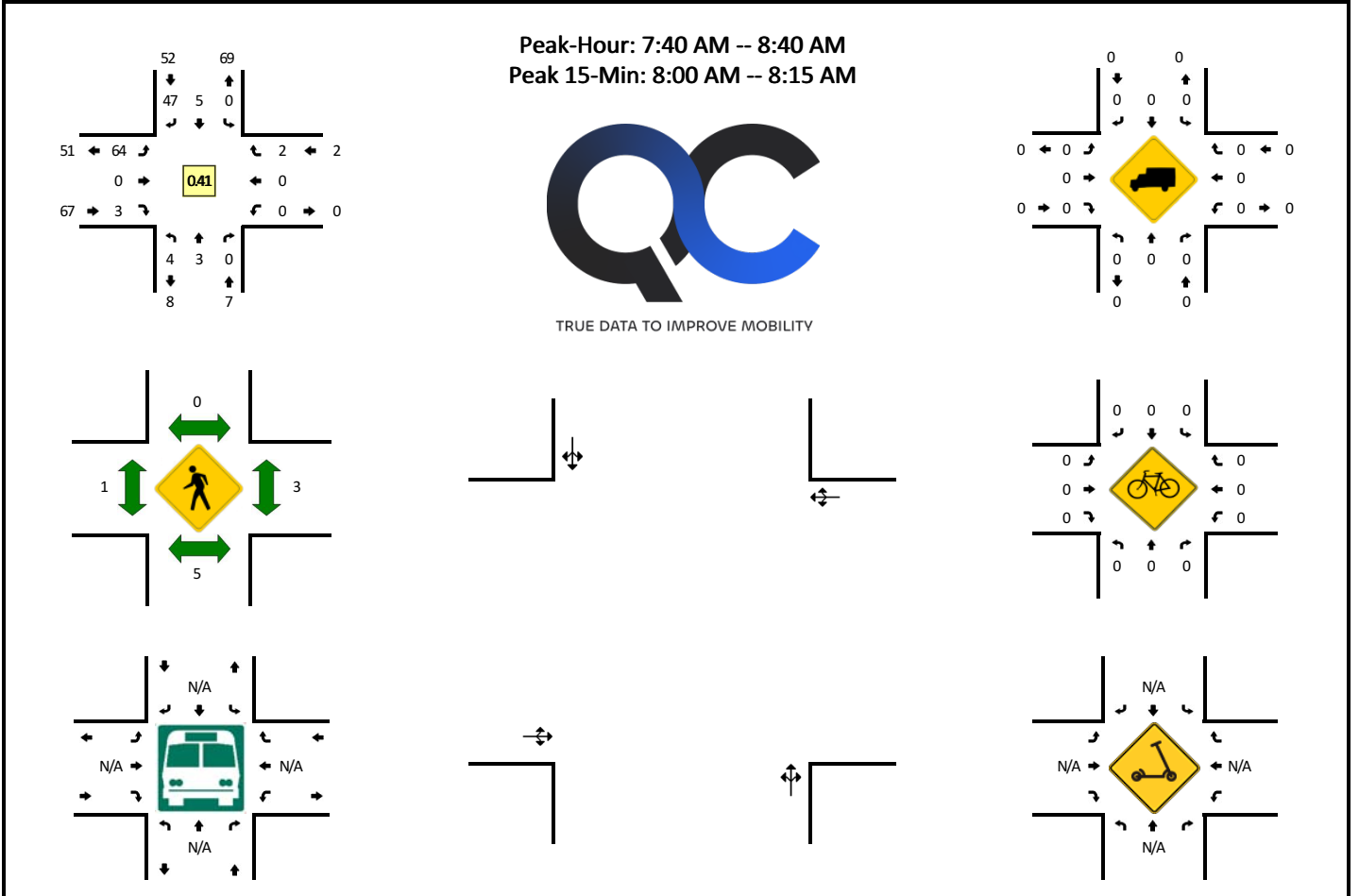

| 5-Min Count Period Beginning At | Cottonwood Dr (Northbound) |      |       |   | Cottonwood Dr (Southbound) |      |       |   | Deep Well Rd (Eastbound) |      |       |   | Deep Well Rd (Westbound) |      |       |   | Total | Hourly Totals |     |
|---------------------------------|----------------------------|------|-------|---|----------------------------|------|-------|---|--------------------------|------|-------|---|--------------------------|------|-------|---|-------|---------------|-----|
|                                 | Left                       | Thru | Right | U | Left                       | Thru | Right | U | Left                     | Thru | Right | U | Left                     | Thru | Right | U |       |               |     |
| 6:00 AM                         | 0                          | 0    | 0     | 0 | 0                          | 0    | 0     | 0 | 0                        | 0    | 0     | 0 | 0                        | 1    | 0     | 0 | 0     | 1             |     |
| 6:05 AM                         | 1                          | 0    | 0     | 0 | 0                          | 0    | 0     | 0 | 0                        | 0    | 0     | 0 | 0                        | 0    | 0     | 0 | 0     | 1             |     |
| 6:10 AM                         | 0                          | 0    | 0     | 0 | 0                          | 0    | 1     | 0 | 0                        | 0    | 0     | 0 | 0                        | 0    | 0     | 0 | 0     | 1             |     |
| 6:15 AM                         | 0                          | 0    | 0     | 0 | 0                          | 0    | 1     | 0 | 0                        | 0    | 1     | 0 | 0                        | 0    | 0     | 0 | 0     | 2             |     |
| 6:20 AM                         | 0                          | 0    | 0     | 0 | 0                          | 0    | 0     | 0 | 0                        | 0    | 0     | 0 | 0                        | 0    | 0     | 0 | 0     | 0             |     |
| 6:25 AM                         | 0                          | 0    | 0     | 0 | 0                          | 0    | 0     | 0 | 0                        | 0    | 1     | 0 | 0                        | 0    | 0     | 0 | 0     | 1             |     |
| 6:30 AM                         | 0                          | 0    | 0     | 0 | 0                          | 0    | 0     | 0 | 0                        | 0    | 0     | 0 | 0                        | 0    | 0     | 0 | 0     | 0             |     |
| 6:35 AM                         | 0                          | 0    | 0     | 0 | 0                          | 0    | 0     | 0 | 0                        | 0    | 0     | 0 | 0                        | 0    | 0     | 0 | 0     | 0             |     |
| 6:40 AM                         | 0                          | 0    | 0     | 0 | 0                          | 0    | 0     | 0 | 0                        | 0    | 0     | 0 | 0                        | 0    | 0     | 0 | 0     | 0             |     |
| 6:45 AM                         | 0                          | 0    | 0     | 0 | 0                          | 0    | 0     | 0 | 0                        | 0    | 0     | 0 | 0                        | 0    | 0     | 0 | 0     | 0             |     |
| 6:50 AM                         | 1                          | 0    | 0     | 0 | 0                          | 0    | 0     | 0 | 0                        | 0    | 0     | 0 | 0                        | 0    | 0     | 0 | 0     | 1             |     |
| 6:55 AM                         | 0                          | 0    | 0     | 0 | 0                          | 0    | 1     | 0 | 0                        | 1    | 0     | 0 | 0                        | 0    | 0     | 0 | 0     | 2             | 9   |
| 7:00 AM                         | 0                          | 1    | 0     | 0 | 0                          | 0    | 0     | 0 | 0                        | 1    | 0     | 0 | 0                        | 0    | 0     | 0 | 0     | 2             | 10  |
| 7:05 AM                         | 1                          | 0    | 0     | 0 | 0                          | 0    | 0     | 0 | 0                        | 0    | 0     | 0 | 0                        | 0    | 0     | 0 | 0     | 1             | 10  |
| 7:10 AM                         | 0                          | 0    | 0     | 0 | 0                          | 0    | 1     | 0 | 0                        | 0    | 0     | 0 | 0                        | 0    | 0     | 0 | 0     | 1             | 10  |
| 7:15 AM                         | 0                          | 1    | 0     | 0 | 0                          | 0    | 1     | 0 | 2                        | 0    | 0     | 0 | 0                        | 0    | 0     | 0 | 0     | 4             | 12  |
| 7:20 AM                         | 0                          | 0    | 0     | 0 | 0                          | 0    | 0     | 0 | 1                        | 0    | 0     | 0 | 0                        | 0    | 0     | 0 | 0     | 1             | 13  |
| 7:25 AM                         | 0                          | 2    | 0     | 0 | 0                          | 0    | 1     | 0 | 1                        | 0    | 1     | 0 | 0                        | 0    | 0     | 0 | 0     | 5             | 17  |
| 7:30 AM                         | 0                          | 0    | 0     | 0 | 0                          | 0    | 0     | 0 | 0                        | 0    | 0     | 0 | 0                        | 0    | 0     | 0 | 0     | 0             | 17  |
| 7:35 AM                         | 0                          | 0    | 0     | 0 | 0                          | 0    | 0     | 0 | 2                        | 0    | 0     | 0 | 0                        | 0    | 0     | 0 | 0     | 2             | 19  |
| 7:40 AM                         | 0                          | 0    | 0     | 0 | 0                          | 0    | 1     | 0 | 1                        | 0    | 0     | 0 | 0                        | 0    | 0     | 0 | 0     | 2             | 21  |
| 7:45 AM                         | 1                          | 1    | 0     | 0 | 0                          | 1    | 1     | 0 | 5                        | 0    | 0     | 0 | 0                        | 0    | 0     | 0 | 0     | 9             | 30  |
| 7:50 AM                         | 0                          | 0    | 0     | 0 | 0                          | 0    | 2     | 0 | 4                        | 0    | 1     | 0 | 0                        | 0    | 0     | 0 | 0     | 7             | 36  |
| 7:55 AM                         | 1                          | 0    | 0     | 0 | 0                          | 0    | 7     | 0 | 6                        | 0    | 0     | 0 | 0                        | 0    | 0     | 0 | 0     | 14            | 48  |
| 8:00 AM                         | 0                          | 0    | 0     | 0 | 0                          | 1    | 12    | 0 | 8                        | 0    | 0     | 0 | 0                        | 0    | 0     | 1 | 0     | 22            | 68  |
| 8:05 AM                         | 0                          | 0    | 0     | 0 | 0                          | 0    | 17    | 0 | 17                       | 0    | 1     | 0 | 0                        | 0    | 0     | 0 | 0     | 35            | 102 |
| 8:10 AM                         | 0                          | 0    | 0     | 0 | 0                          | 0    | 2     | 0 | 19                       | 0    | 0     | 0 | 0                        | 0    | 0     | 0 | 0     | 21            | 122 |
| 8:15 AM                         | 0                          | 1    | 0     | 0 | 0                          | 1    | 3     | 0 | 1                        | 0    | 0     | 0 | 0                        | 0    | 0     | 0 | 0     | 6             | 124 |
| 8:20 AM                         | 0                          | 0    | 0     | 0 | 0                          | 1    | 0     | 0 | 1                        | 0    | 0     | 0 | 0                        | 0    | 0     | 0 | 0     | 2             | 125 |
| 8:25 AM                         | 0                          | 1    | 0     | 0 | 0                          | 1    | 0     | 0 | 1                        | 0    | 0     | 0 | 0                        | 0    | 0     | 0 | 0     | 3             | 123 |
| 8:30 AM                         | 1                          | 0    | 0     | 0 | 0                          | 0    | 2     | 0 | 1                        | 0    | 0     | 0 | 0                        | 0    | 0     | 0 | 0     | 4             | 127 |
| 8:35 AM                         | 1                          | 0    | 0     | 0 | 0                          | 0    | 0     | 0 | 0                        | 0    | 1     | 0 | 0                        | 0    | 0     | 1 | 0     | 3             | 128 |
| 8:40 AM                         | 0                          | 0    | 0     | 0 | 0                          | 0    | 1     | 0 | 1                        | 0    | 0     | 0 | 0                        | 0    | 0     | 0 | 0     | 2             | 128 |
| 8:45 AM                         | 1                          | 0    | 0     | 0 | 0                          | 0    | 0     | 0 | 0                        | 0    | 0     | 0 | 0                        | 0    | 0     | 0 | 0     | 1             | 120 |
| 8:50 AM                         | 0                          | 1    | 0     | 0 | 0                          | 0    | 2     | 0 | 2                        | 0    | 0     | 0 | 0                        | 1    | 0     | 0 | 0     | 6             | 119 |
| 8:55 AM                         | 0                          | 0    | 0     | 0 | 0                          | 0    | 0     | 0 | 0                        | 0    | 0     | 0 | 0                        | 0    | 0     | 0 | 0     | 0             | 105 |
| 9:00 AM                         | 0                          | 0    | 0     | 0 | 0                          | 0    | 0     | 0 | 1                        | 0    | 0     | 0 | 0                        | 0    | 0     | 0 | 0     | 1             | 84  |
| 9:05 AM                         | 1                          | 0    | 0     | 0 | 0                          | 1    | 0     | 0 | 0                        | 0    | 0     | 0 | 0                        | 0    | 0     | 0 | 0     | 2             | 51  |

### Attachment B

| 5-Min Count Period Beginning At | Cottonwood Dr (Northbound) |      |       |   | Cottonwood Dr (Southbound) |      |       |   | Deep Well Rd (Eastbound) |      |       |   | Deep Well Rd (Westbound) |      |       |   | Total | Hourly Totals |
|---------------------------------|----------------------------|------|-------|---|----------------------------|------|-------|---|--------------------------|------|-------|---|--------------------------|------|-------|---|-------|---------------|
|                                 | Left                       | Thru | Right | U | Left                       | Thru | Right | U | Left                     | Thru | Right | U | Left                     | Thru | Right | U |       |               |
| 9:10 AM                         | 0                          | 0    | 0     | 0 | 0                          | 1    | 0     | 0 | 0                        | 0    | 0     | 0 | 0                        | 0    | 0     | 0 | 1     | 31            |
| 9:15 AM                         | 0                          | 0    | 0     | 0 | 0                          | 0    | 0     | 0 | 0                        | 0    | 0     | 0 | 0                        | 0    | 0     | 0 | 0     | 25            |
| 9:20 AM                         | 0                          | 0    | 0     | 0 | 1                          | 0    | 0     | 0 | 1                        | 0    | 0     | 0 | 0                        | 1    | 0     | 0 | 3     | 26            |
| 9:25 AM                         | 0                          | 0    | 0     | 0 | 0                          | 0    | 0     | 0 | 0                        | 0    | 0     | 0 | 0                        | 0    | 0     | 0 | 0     | 23            |
| 9:30 AM                         | 0                          | 0    | 0     | 0 | 0                          | 0    | 0     | 0 | 0                        | 0    | 0     | 0 | 0                        | 0    | 0     | 0 | 0     | 19            |
| 9:35 AM                         | 0                          | 0    | 0     | 0 | 0                          | 0    | 1     | 0 | 0                        | 0    | 0     | 0 | 0                        | 0    | 0     | 0 | 1     | 17            |
| 9:40 AM                         | 0                          | 0    | 0     | 0 | 0                          | 0    | 1     | 0 | 0                        | 0    | 0     | 0 | 0                        | 0    | 0     | 0 | 1     | 16            |
| 9:45 AM                         | 0                          | 1    | 0     | 0 | 0                          | 0    | 2     | 0 | 1                        | 0    | 0     | 0 | 0                        | 0    | 0     | 0 | 4     | 19            |
| 9:50 AM                         | 0                          | 0    | 0     | 0 | 0                          | 0    | 1     | 0 | 0                        | 0    | 0     | 0 | 0                        | 0    | 0     | 0 | 1     | 14            |
| 9:55 AM                         | 0                          | 0    | 0     | 0 | 0                          | 0    | 1     | 0 | 0                        | 0    | 0     | 0 | 0                        | 0    | 0     | 0 | 1     | 15            |
| 10:00 AM                        | 0                          | 0    | 0     | 0 | 0                          | 0    | 0     | 0 | 1                        | 0    | 0     | 0 | 0                        | 0    | 0     | 0 | 1     | 15            |
| 10:05 AM                        | 0                          | 0    | 0     | 0 | 1                          | 0    | 0     | 0 | 0                        | 0    | 0     | 0 | 0                        | 0    | 0     | 0 | 1     | 14            |
| 10:10 AM                        | 0                          | 0    | 0     | 0 | 0                          | 0    | 3     | 0 | 0                        | 0    | 0     | 0 | 0                        | 0    | 0     | 0 | 3     | 16            |
| 10:15 AM                        | 0                          | 0    | 0     | 0 | 0                          | 0    | 0     | 0 | 1                        | 0    | 1     | 0 | 0                        | 0    | 0     | 0 | 2     | 18            |
| 10:20 AM                        | 0                          | 0    | 0     | 0 | 0                          | 0    | 0     | 0 | 0                        | 0    | 0     | 0 | 0                        | 0    | 0     | 0 | 0     | 15            |
| 10:25 AM                        | 0                          | 0    | 0     | 0 | 0                          | 0    | 0     | 0 | 0                        | 0    | 1     | 0 | 0                        | 0    | 1     | 0 | 2     | 17            |
| 10:30 AM                        | 0                          | 1    | 0     | 0 | 0                          | 1    | 1     | 0 | 0                        | 0    | 0     | 0 | 0                        | 0    | 0     | 0 | 3     | 20            |
| 10:35 AM                        | 0                          | 0    | 0     | 0 | 0                          | 0    | 0     | 0 | 1                        | 0    | 0     | 0 | 0                        | 0    | 0     | 0 | 1     | 20            |
| 10:40 AM                        | 0                          | 0    | 0     | 0 | 0                          | 1    | 0     | 0 | 2                        | 0    | 0     | 0 | 0                        | 0    | 0     | 0 | 3     | 22            |
| 10:45 AM                        | 0                          | 1    | 0     | 0 | 0                          | 1    | 0     | 0 | 0                        | 0    | 0     | 0 | 0                        | 0    | 0     | 0 | 2     | 20            |
| 10:50 AM                        | 0                          | 0    | 0     | 0 | 1                          | 0    | 0     | 0 | 0                        | 0    | 0     | 0 | 0                        | 0    | 1     | 0 | 2     | 21            |
| 10:55 AM                        | 0                          | 0    | 0     | 0 | 0                          | 0    | 2     | 0 | 0                        | 0    | 0     | 0 | 0                        | 0    | 0     | 0 | 2     | 22            |
| 11:00 AM                        | 0                          | 1    | 0     | 0 | 0                          | 0    | 0     | 0 | 0                        | 0    | 0     | 0 | 0                        | 1    | 0     | 0 | 2     | 23            |
| 11:05 AM                        | 0                          | 0    | 0     | 0 | 0                          | 0    | 2     | 0 | 0                        | 0    | 0     | 0 | 0                        | 0    | 0     | 0 | 2     | 24            |
| 11:10 AM                        | 0                          | 0    | 0     | 0 | 0                          | 2    | 0     | 0 | 0                        | 0    | 0     | 0 | 0                        | 0    | 0     | 0 | 2     | 23            |
| 11:15 AM                        | 0                          | 0    | 0     | 0 | 0                          | 0    | 0     | 0 | 0                        | 0    | 0     | 0 | 0                        | 0    | 0     | 0 | 0     | 21            |
| 11:20 AM                        | 0                          | 1    | 0     | 0 | 0                          | 0    | 0     | 0 | 1                        | 0    | 0     | 0 | 0                        | 0    | 0     | 0 | 2     | 23            |
| 11:25 AM                        | 0                          | 0    | 0     | 0 | 0                          | 2    | 1     | 0 | 0                        | 0    | 0     | 0 | 0                        | 0    | 0     | 0 | 3     | 24            |
| 11:30 AM                        | 0                          | 0    | 0     | 0 | 1                          | 0    | 1     | 0 | 1                        | 0    | 0     | 0 | 0                        | 0    | 0     | 0 | 3     | 24            |
| 11:35 AM                        | 1                          | 0    | 0     | 0 | 0                          | 0    | 1     | 0 | 0                        | 0    | 0     | 0 | 0                        | 0    | 0     | 0 | 2     | 25            |
| 11:40 AM                        | 0                          | 0    | 0     | 0 | 0                          | 1    | 0     | 0 | 1                        | 0    | 0     | 0 | 0                        | 0    | 0     | 0 | 2     | 24            |
| 11:45 AM                        | 0                          | 1    | 0     | 0 | 0                          | 0    | 0     | 0 | 1                        | 0    | 0     | 0 | 0                        | 0    | 0     | 0 | 2     | 24            |
| 11:50 AM                        | 0                          | 1    | 0     | 0 | 0                          | 0    | 1     | 0 | 4                        | 0    | 0     | 0 | 0                        | 1    | 0     | 0 | 7     | 29            |
| 11:55 AM                        | 0                          | 0    | 0     | 0 | 0                          | 0    | 0     | 0 | 0                        | 0    | 0     | 0 | 0                        | 1    | 0     | 0 | 1     | 28            |
| 12:00 PM                        | 0                          | 0    | 0     | 0 | 0                          | 0    | 0     | 0 | 0                        | 0    | 1     | 0 | 0                        | 0    | 0     | 0 | 1     | 27            |
| 12:05 PM                        | 0                          | 0    | 0     | 0 | 0                          | 1    | 1     | 0 | 1                        | 0    | 0     | 0 | 0                        | 0    | 0     | 0 | 3     | 28            |
| 12:10 PM                        | 0                          | 0    | 0     | 0 | 0                          | 0    | 3     | 0 | 0                        | 0    | 0     | 0 | 0                        | 0    | 0     | 0 | 3     | 29            |
| 12:15 PM                        | 1                          | 0    | 0     | 0 | 0                          | 0    | 2     | 0 | 0                        | 0    | 0     | 0 | 0                        | 0    | 0     | 0 | 3     | 32            |
| 12:20 PM                        | 0                          | 0    | 0     | 0 | 0                          | 0    | 1     | 0 | 2                        | 0    | 0     | 0 | 0                        | 0    | 0     | 0 | 3     | 33            |
| 12:25 PM                        | 0                          | 0    | 0     | 0 | 0                          | 0    | 0     | 0 | 1                        | 0    | 0     | 0 | 0                        | 0    | 0     | 0 | 1     | 31            |
| 12:30 PM                        | 1                          | 0    | 0     | 0 | 0                          | 0    | 1     | 0 | 0                        | 0    | 0     | 0 | 0                        | 0    | 0     | 0 | 2     | 30            |
| 12:35 PM                        | 0                          | 0    | 0     | 0 | 0                          | 1    | 1     | 0 | 0                        | 0    | 0     | 0 | 0                        | 0    | 0     | 0 | 2     | 30            |
| 12:40 PM                        | 0                          | 0    | 0     | 0 | 0                          | 0    | 0     | 0 | 2                        | 0    | 0     | 0 | 0                        | 0    | 0     | 0 | 2     | 30            |
| 12:45 PM                        | 0                          | 0    | 0     | 0 | 1                          | 0    | 0     | 0 | 0                        | 0    | 1     | 0 | 0                        | 0    | 0     | 0 | 2     | 30            |
| 12:50 PM                        | 0                          | 0    | 0     | 0 | 0                          | 0    | 1     | 0 | 1                        | 0    | 0     | 0 | 0                        | 0    | 0     | 0 | 2     | 25            |
| 12:55 PM                        | 0                          | 0    | 0     | 0 | 0                          | 0    | 0     | 0 | 0                        | 0    | 0     | 0 | 0                        | 0    | 0     | 0 | 0     | 24            |
| 1:00 PM                         | 0                          | 0    | 0     | 0 | 0                          | 0    | 1     | 0 | 1                        | 0    | 0     | 0 | 0                        | 0    | 0     | 0 | 2     | 25            |
| 1:05 PM                         | 0                          | 0    | 0     | 0 | 0                          | 0    | 0     | 0 | 1                        | 0    | 0     | 0 | 0                        | 0    | 0     | 0 | 1     | 23            |
| 1:10 PM                         | 0                          | 0    | 0     | 0 | 0                          | 0    | 0     | 0 | 1                        | 0    | 1     | 0 | 0                        | 0    | 0     | 0 | 2     | 22            |
| 1:15 PM                         | 0                          | 1    | 0     | 0 | 0                          | 0    | 1     | 0 | 0                        | 0    | 0     | 0 | 0                        | 0    | 0     | 0 | 2     | 21            |
| 1:20 PM                         | 0                          | 0    | 0     | 0 | 0                          | 0    | 0     | 0 | 0                        | 0    | 0     | 0 | 0                        | 0    | 0     | 0 | 0     | 18            |
| 1:25 PM                         | 0                          | 1    | 1     | 0 | 0                          | 0    | 1     | 0 | 1                        | 0    | 0     | 0 | 0                        | 0    | 0     | 0 | 4     | 21            |
| 1:30 PM                         | 0                          | 0    | 0     | 0 | 0                          | 0    | 1     | 0 | 0                        | 0    | 0     | 0 | 0                        | 1    | 0     | 0 | 2     | 21            |
| 1:35 PM                         | 0                          | 0    | 0     | 0 | 0                          | 0    | 0     | 0 | 0                        | 1    | 0     | 0 | 0                        | 0    | 0     | 0 | 2     | 21            |
| 1:40 PM                         | 1                          | 0    | 0     | 0 | 0                          | 0    | 0     | 0 | 2                        | 1    | 0     | 0 | 0                        | 0    | 0     | 0 | 4     | 23            |
| 1:45 PM                         | 0                          | 0    | 0     | 0 | 0                          | 0    | 0     | 0 | 2                        | 0    | 0     | 0 | 0                        | 0    | 0     | 0 | 2     | 23            |
| 1:50 PM                         | 0                          | 0    | 0     | 0 | 0                          | 0    | 1     | 0 | 1                        | 0    | 0     | 0 | 0                        | 0    | 0     | 0 | 2     | 23            |
| 1:55 PM                         | 0                          | 0    | 0     | 0 | 0                          | 0    | 1     | 0 | 0                        | 0    | 0     | 0 | 0                        | 0    | 0     | 0 | 1     | 24            |
| 2:00 PM                         | 0                          | 0    | 0     | 0 | 0                          | 0    | 2     | 0 | 1                        | 0    | 1     | 0 | 0                        | 0    | 0     | 0 | 4     | 26            |
| 2:05 PM                         | 0                          | 1    | 0     | 0 | 0                          | 1    | 1     | 0 | 2                        | 0    | 0     | 0 | 0                        | 0    | 0     | 0 | 5     | 30            |
| 2:10 PM                         | 0                          | 0    | 0     | 0 | 0                          | 0    | 4     | 0 | 0                        | 0    | 0     | 0 | 0                        | 0    | 0     | 0 | 4     | 32            |
| 2:15 PM                         | 0                          | 0    | 0     | 0 | 0                          | 0    | 0     | 0 | 1                        | 0    | 0     | 0 | 0                        | 0    | 0     | 0 | 1     | 31            |
| 2:20 PM                         | 0                          | 1    | 0     | 0 | 0                          | 0    | 2     | 0 | 0                        | 0    | 1     | 0 | 0                        | 0    | 0     | 0 | 4     | 35            |
| 2:25 PM                         | 0                          | 0    | 0     | 0 | 1                          | 0    | 3     | 0 | 0                        | 0    | 0     | 0 | 0                        | 0    | 0     | 0 | 4     | 35            |
| 2:30 PM                         | 0                          | 0    | 0     | 0 | 0                          | 0    | 1     | 0 | 0                        | 0    | 1     | 0 | 0                        | 0    | 0     | 0 | 2     | 35            |
| 2:35 PM                         | 0                          | 0    | 0     | 0 | 0                          | 0    | 5     | 0 | 1                        | 0    | 0     | 0 | 0                        | 0    | 0     | 0 | 6     | 39            |
| 2:40 PM                         | 1                          | 0    | 0     | 0 | 0                          | 0    | 5     | 0 | 0                        | 0    | 0     | 0 | 0                        | 0    | 0     | 0 | 6     | 41            |
| 2:45 PM                         | 0                          | 1    | 0     | 0 | 0                          | 0    | 9     | 0 | 3                        | 0    | 0     | 0 | 0                        | 0    | 0     | 0 | 13    | 52            |
| 2:50 PM                         | 0                          | 0    | 0     | 0 | 0                          | 0    | 16    | 0 | 28                       | 0    | 2     | 0 | 0                        | 1    | 0     | 0 | 47    | 97            |
| 2:55 PM                         | 0                          | 1    | 0     | 0 | 0                          | 0    | 3     | 0 | 12                       | 0    | 1     | 0 | 0                        | 0    | 0     | 0 | 17    | 113           |
| 3:00 PM                         | 0                          | 0    | 0     | 0 | 0                          | 1    | 0     | 0 | 4                        | 0    | 0     | 0 | 0                        | 0    | 0     | 0 | 5     | 114           |
| 3:05 PM                         | 0                          | 0    | 0     | 0 | 0                          | 1    | 2     | 0 | 1                        | 0    | 0     | 0 | 0                        | 0    | 0     | 0 | 4     | 113           |
| 3:10 PM                         | 0                          | 0    | 0     | 0 | 0                          | 0    | 2     | 0 | 1                        | 0    | 0     | 0 | 0                        | 0    | 0     | 0 | 3     | 112           |
| 3:15 PM                         | 0                          | 0    | 0     | 0 | 0                          | 0    | 1     | 0 | 0                        | 0    | 0     | 0 | 0                        | 0    | 0     | 0 | 1     | 112           |
| 3:20 PM                         | 1                          | 0    | 0     | 0 | 0                          | 1    | 1     | 0 | 2                        | 0    | 1     | 0 | 0                        | 0    | 0     | 0 | 6     | 114           |
| 3:25 PM                         | 0                          | 0    | 0     | 0 | 0                          | 0    | 2     | 0 | 0                        | 0    | 0     | 0 | 0                        | 0    | 0     | 0 | 2     | 112           |
| 3:30 PM                         | 0                          | 1    | 0     | 0 | 0                          | 1    | 0     | 0 | 1                        | 0    | 0     | 0 | 0                        | 0    | 0     | 0 | 3     | 113           |
| 3:35 PM                         | 1                          | 0    | 0     | 0 | 0                          | 0    | 0     | 0 | 1                        | 0    | 0     | 0 | 0                        | 0    | 0     | 0 | 2     | 109           |
| 3:40 PM                         | 0                          | 0    | 0     | 0 | 0                          | 0    | 0     | 0 | 0                        | 0    | 0     | 0 | 0                        | 0    | 0     | 0 | 0     | 103           |
| 3:45 PM                         | 0                          | 0    | 0     | 0 | 0                          | 0    | 1     | 0 | 2                        | 0    | 0     | 0 | 0                        | 0    | 0     | 0 | 3     | 93            |
| 3:50 PM                         | 1                          | 0    | 0     | 0 | 0                          | 0    | 0     | 0 | 0                        | 0    | 0     | 0 | 0                        | 0    | 0     | 0 | 1     | 47            |
| 3:55 PM                         | 0                          | 1    | 0     | 0 | 0                          | 0    | 0     | 0 | 0                        | 0    | 0     | 0 | 0                        | 0    | 0     | 0 | 1     | 31            |
| 4:00 PM                         | 0                          | 0    | 0     | 0 | 0                          | 0    | 0     | 0 | 0                        | 0    | 0     | 0 | 0                        | 0    | 0     | 0 | 0     | 26            |
| 4:05 PM                         | 0                          | 0    | 0     | 0 | 0                          | 0    | 2     | 0 | 0                        | 0    | 0     | 0 | 0                        | 0    | 0     | 0 | 2     | 24            |
| 4:10 PM                         | 0                          | 0    | 0     | 0 | 0                          | 1    | 1     | 0 | 1                        | 0    | 0     | 0 | 0                        | 0    | 0     | 0 | 3     | 24            |
| 4:15 PM                         | 0                          | 0    | 0     | 0 | 0                          | 1    | 2     | 0 | 2                        | 0    | 0     | 0 | 0                        | 0    | 0     | 0 | 5     | 28            |
| 4:20 PM                         | 0                          | 0    | 0     | 0 | 0                          | 1    | 0     | 0 | 1                        | 0    | 0     | 0 | 0                        | 0    | 0     | 0 | 2     | 24            |
| 4:25 PM                         | 1                          | 0    | 0     | 0 | 0                          | 0    | 0     | 0 | 0                        | 0    | 0     | 0 | 0                        | 0    | 0     | 0 | 1     | 23            |
| 4:30 PM                         | 0                          | 0    | 0     | 0 | 0                          | 1    | 0     | 0 | 1                        | 0    | 1     | 0 | 0                        | 0    | 0     | 0 | 3     | 23            |

**Attachment B**

| 5-Min Count Period Beginning At | Cottonwood Dr (Northbound) |      |       |   | Cottonwood Dr (Southbound) |      |       |   | Deep Well Rd (Eastbound) |      |       |   | Deep Well Rd (Westbound) |      |       |   | Total | Hourly Totals |
|---------------------------------|----------------------------|------|-------|---|----------------------------|------|-------|---|--------------------------|------|-------|---|--------------------------|------|-------|---|-------|---------------|
|                                 | Left                       | Thru | Right | U | Left                       | Thru | Right | U | Left                     | Thru | Right | U | Left                     | Thru | Right | U |       |               |
| 4:35 PM                         | 1                          | 0    | 0     | 0 | 0                          | 1    | 1     | 0 | 1                        | 0    | 1     | 0 | 0                        | 0    | 0     | 0 | 5     | 26            |
| 4:40 PM                         | 0                          | 0    | 0     | 0 | 0                          | 0    | 0     | 0 | 0                        | 0    | 0     | 0 | 0                        | 0    | 0     | 0 | 0     | 26            |
| 4:45 PM                         | 0                          | 0    | 0     | 0 | 0                          | 0    | 2     | 0 | 0                        | 0    | 0     | 0 | 0                        | 0    | 0     | 0 | 2     | 25            |
| 4:50 PM                         | 0                          | 0    | 0     | 0 | 0                          | 0    | 0     | 0 | 3                        | 0    | 1     | 0 | 0                        | 0    | 0     | 0 | 4     | 28            |
| 4:55 PM                         | 0                          | 0    | 0     | 0 | 0                          | 1    | 0     | 0 | 1                        | 0    | 1     | 0 | 0                        | 0    | 0     | 0 | 3     | 30            |
| 5:00 PM                         | 2                          | 1    | 0     | 0 | 0                          | 0    | 1     | 0 | 0                        | 0    | 1     | 0 | 0                        | 0    | 0     | 0 | 5     | 35            |
| 5:05 PM                         | 0                          | 2    | 0     | 0 | 0                          | 0    | 0     | 0 | 2                        | 0    | 0     | 0 | 0                        | 0    | 0     | 0 | 4     | 37            |
| 5:10 PM                         | 0                          | 0    | 0     | 0 | 1                          | 0    | 0     | 0 | 0                        | 0    | 0     | 0 | 0                        | 0    | 0     | 0 | 1     | 35            |
| 5:15 PM                         | 0                          | 0    | 0     | 0 | 0                          | 1    | 1     | 0 | 1                        | 0    | 0     | 0 | 0                        | 0    | 0     | 0 | 3     | 33            |
| 5:20 PM                         | 2                          | 0    | 0     | 0 | 0                          | 0    | 0     | 0 | 1                        | 0    | 0     | 0 | 0                        | 0    | 0     | 0 | 3     | 34            |
| 5:25 PM                         | 0                          | 0    | 0     | 0 | 0                          | 0    | 2     | 0 | 1                        | 0    | 1     | 0 | 0                        | 1    | 0     | 0 | 5     | 38            |
| 5:30 PM                         | 0                          | 0    | 0     | 0 | 0                          | 0    | 3     | 0 | 1                        | 0    | 0     | 0 | 0                        | 0    | 0     | 0 | 4     | 39            |
| 5:35 PM                         | 0                          | 0    | 0     | 0 | 0                          | 0    | 0     | 0 | 0                        | 0    | 1     | 0 | 0                        | 0    | 0     | 0 | 1     | 35            |
| 5:40 PM                         | 1                          | 0    | 0     | 0 | 0                          | 0    | 0     | 0 | 2                        | 0    | 0     | 0 | 0                        | 0    | 0     | 0 | 3     | 38            |
| 5:45 PM                         | 0                          | 0    | 0     | 0 | 0                          | 2    | 0     | 0 | 0                        | 0    | 0     | 0 | 0                        | 0    | 0     | 0 | 2     | 38            |
| 5:50 PM                         | 1                          | 1    | 0     | 0 | 0                          | 0    | 0     | 0 | 0                        | 0    | 0     | 0 | 0                        | 0    | 0     | 0 | 2     | 36            |
| 5:55 PM                         | 1                          | 0    | 0     | 0 | 0                          | 0    | 0     | 0 | 1                        | 0    | 0     | 0 | 0                        | 0    | 0     | 0 | 2     | 35            |
| 6:00 PM                         | 0                          | 0    | 0     | 0 | 0                          | 1    | 1     | 0 | 0                        | 0    | 0     | 0 | 0                        | 0    | 0     | 0 | 2     | 32            |
| 6:05 PM                         | 0                          | 0    | 0     | 0 | 0                          | 1    | 3     | 0 | 1                        | 0    | 0     | 0 | 0                        | 0    | 0     | 0 | 5     | 33            |
| 6:10 PM                         | 0                          | 0    | 0     | 0 | 0                          | 0    | 1     | 0 | 2                        | 0    | 0     | 0 | 0                        | 0    | 0     | 0 | 3     | 35            |
| 6:15 PM                         | 0                          | 0    | 0     | 0 | 1                          | 0    | 1     | 0 | 0                        | 0    | 1     | 0 | 0                        | 0    | 0     | 0 | 3     | 35            |
| 6:20 PM                         | 1                          | 1    | 0     | 0 | 0                          | 1    | 0     | 0 | 0                        | 0    | 0     | 0 | 0                        | 0    | 0     | 0 | 3     | 35            |
| 6:25 PM                         | 0                          | 0    | 0     | 0 | 0                          | 0    | 1     | 0 | 0                        | 0    | 0     | 0 | 0                        | 0    | 0     | 0 | 1     | 31            |
| 6:30 PM                         | 0                          | 0    | 0     | 0 | 1                          | 1    | 1     | 0 | 0                        | 0    | 1     | 0 | 0                        | 0    | 0     | 0 | 4     | 31            |
| 6:35 PM                         | 0                          | 0    | 0     | 0 | 0                          | 1    | 2     | 0 | 0                        | 0    | 0     | 0 | 1                        | 0    | 0     | 0 | 4     | 34            |
| 6:40 PM                         | 0                          | 0    | 0     | 0 | 0                          | 0    | 0     | 0 | 2                        | 0    | 0     | 0 | 0                        | 0    | 0     | 0 | 2     | 33            |
| 6:45 PM                         | 0                          | 0    | 0     | 0 | 0                          | 0    | 0     | 0 | 0                        | 0    | 0     | 0 | 0                        | 0    | 0     | 0 | 0     | 31            |
| 6:50 PM                         | 1                          | 1    | 0     | 0 | 1                          | 0    | 0     | 0 | 2                        | 0    | 1     | 0 | 0                        | 0    | 0     | 0 | 6     | 35            |
| 6:55 PM                         | 0                          | 0    | 0     | 0 | 0                          | 0    | 1     | 0 | 0                        | 0    | 0     | 0 | 0                        | 0    | 0     | 0 | 1     | 34            |
| 7:00 PM                         | 0                          | 0    | 0     | 0 | 0                          | 0    | 0     | 0 | 0                        | 0    | 0     | 0 | 0                        | 0    | 0     | 0 | 0     | 32            |
| 7:05 PM                         | 1                          | 0    | 0     | 0 | 0                          | 0    | 1     | 0 | 0                        | 0    | 0     | 0 | 0                        | 0    | 0     | 0 | 2     | 29            |
| 7:10 PM                         | 0                          | 0    | 0     | 0 | 0                          | 1    | 0     | 0 | 0                        | 0    | 0     | 0 | 0                        | 0    | 0     | 0 | 1     | 27            |
| 7:15 PM                         | 0                          | 0    | 0     | 0 | 0                          | 0    | 1     | 0 | 0                        | 0    | 0     | 0 | 0                        | 0    | 0     | 0 | 1     | 25            |
| 7:20 PM                         | 0                          | 0    | 0     | 0 | 0                          | 0    | 0     | 0 | 1                        | 0    | 0     | 0 | 0                        | 0    | 0     | 0 | 1     | 23            |
| 7:25 PM                         | 1                          | 0    | 0     | 0 | 0                          | 1    | 1     | 0 | 1                        | 0    | 0     | 0 | 0                        | 0    | 0     | 0 | 4     | 26            |
| 7:30 PM                         | 0                          | 1    | 0     | 0 | 0                          | 0    | 1     | 0 | 0                        | 0    | 0     | 0 | 0                        | 0    | 0     | 0 | 2     | 24            |
| 7:35 PM                         | 0                          | 0    | 0     | 0 | 0                          | 0    | 0     | 0 | 1                        | 0    | 0     | 0 | 0                        | 0    | 0     | 0 | 1     | 21            |
| 7:40 PM                         | 0                          | 0    | 0     | 0 | 0                          | 1    | 1     | 0 | 1                        | 0    | 0     | 0 | 0                        | 0    | 0     | 0 | 3     | 22            |
| 7:45 PM                         | 0                          | 0    | 0     | 0 | 0                          | 0    | 0     | 0 | 1                        | 0    | 0     | 0 | 0                        | 0    | 0     | 0 | 1     | 23            |
| 7:50 PM                         | 0                          | 0    | 0     | 0 | 0                          | 0    | 0     | 0 | 0                        | 0    | 1     | 0 | 0                        | 0    | 0     | 0 | 1     | 18            |
| 7:55 PM                         | 0                          | 0    | 0     | 0 | 0                          | 0    | 0     | 0 | 0                        | 0    | 0     | 0 | 0                        | 0    | 0     | 0 | 0     | 17            |
| 8:00 PM                         | 0                          | 0    | 0     | 0 | 0                          | 0    | 0     | 0 | 1                        | 0    | 0     | 0 | 0                        | 0    | 0     | 0 | 1     | 18            |
| 8:05 PM                         | 0                          | 0    | 0     | 0 | 0                          | 0    | 0     | 0 | 0                        | 0    | 0     | 0 | 0                        | 0    | 0     | 0 | 0     | 16            |
| 8:10 PM                         | 0                          | 0    | 0     | 0 | 0                          | 0    | 0     | 0 | 0                        | 0    | 0     | 0 | 0                        | 0    | 0     | 0 | 0     | 15            |
| 8:15 PM                         | 0                          | 1    | 0     | 0 | 0                          | 0    | 0     | 0 | 1                        | 0    | 0     | 0 | 0                        | 0    | 0     | 0 | 2     | 16            |
| 8:20 PM                         | 0                          | 0    | 0     | 0 | 0                          | 0    | 0     | 0 | 0                        | 0    | 0     | 0 | 0                        | 0    | 0     | 0 | 0     | 15            |
| 8:25 PM                         | 0                          | 0    | 0     | 0 | 0                          | 1    | 0     | 0 | 0                        | 0    | 0     | 0 | 0                        | 0    | 0     | 0 | 1     | 12            |
| 8:30 PM                         | 0                          | 0    | 0     | 0 | 0                          | 0    | 0     | 0 | 0                        | 0    | 0     | 0 | 0                        | 0    | 0     | 0 | 0     | 10            |
| 8:35 PM                         | 0                          | 0    | 0     | 0 | 0                          | 0    | 0     | 0 | 1                        | 0    | 0     | 0 | 0                        | 0    | 0     | 0 | 1     | 10            |
| 8:40 PM                         | 0                          | 0    | 0     | 0 | 0                          | 0    | 0     | 0 | 0                        | 0    | 0     | 0 | 0                        | 0    | 0     | 0 | 0     | 7             |
| 8:45 PM                         | 0                          | 0    | 0     | 0 | 0                          | 1    | 1     | 0 | 0                        | 0    | 0     | 0 | 0                        | 0    | 0     | 0 | 2     | 8             |
| 8:50 PM                         | 0                          | 0    | 0     | 0 | 0                          | 1    | 0     | 0 | 0                        | 0    | 0     | 0 | 0                        | 0    | 0     | 0 | 1     | 8             |
| 8:55 PM                         | 0                          | 0    | 0     | 0 | 0                          | 0    | 2     | 0 | 1                        | 0    | 0     | 0 | 0                        | 0    | 0     | 0 | 3     | 11            |
| 9:00 PM                         | 0                          | 0    | 0     | 0 | 0                          | 0    | 1     | 0 | 0                        | 0    | 0     | 0 | 0                        | 0    | 0     | 0 | 1     | 11            |
| 9:05 PM                         | 0                          | 0    | 0     | 0 | 0                          | 0    | 0     | 0 | 0                        | 0    | 0     | 0 | 0                        | 0    | 0     | 0 | 0     | 11            |
| 9:10 PM                         | 0                          | 0    | 0     | 0 | 0                          | 0    | 0     | 0 | 0                        | 0    | 0     | 0 | 0                        | 0    | 0     | 0 | 0     | 11            |
| 9:15 PM                         | 0                          | 0    | 0     | 0 | 0                          | 0    | 0     | 0 | 0                        | 0    | 0     | 0 | 0                        | 0    | 0     | 0 | 0     | 9             |
| 9:20 PM                         | 0                          | 0    | 0     | 0 | 0                          | 0    | 0     | 0 | 1                        | 0    | 0     | 0 | 0                        | 0    | 0     | 0 | 1     | 10            |
| 9:25 PM                         | 0                          | 0    | 0     | 0 | 0                          | 0    | 0     | 0 | 0                        | 0    | 0     | 0 | 0                        | 0    | 0     | 0 | 0     | 9             |
| 9:30 PM                         | 0                          | 0    | 0     | 0 | 0                          | 0    | 1     | 0 | 0                        | 0    | 0     | 0 | 0                        | 0    | 0     | 0 | 1     | 10            |
| 9:35 PM                         | 0                          | 0    | 0     | 0 | 0                          | 0    | 2     | 0 | 1                        | 0    | 0     | 0 | 0                        | 0    | 0     | 0 | 3     | 12            |
| 9:40 PM                         | 0                          | 0    | 0     | 0 | 0                          | 0    | 0     | 0 | 0                        | 0    | 0     | 0 | 0                        | 0    | 0     | 0 | 0     | 12            |
| 9:45 PM                         | 0                          | 0    | 0     | 0 | 0                          | 0    | 0     | 0 | 0                        | 0    | 0     | 0 | 0                        | 0    | 0     | 0 | 0     | 10            |
| 9:50 PM                         | 0                          | 0    | 0     | 0 | 0                          | 0    | 0     | 0 | 1                        | 0    | 0     | 0 | 0                        | 0    | 0     | 0 | 1     | 10            |
| 9:55 PM                         | 0                          | 1    | 0     | 0 | 0                          | 1    | 0     | 0 | 0                        | 0    | 1     | 0 | 0                        | 0    | 0     | 0 | 3     | 10            |
| Peak 15-Min Flowrates           | Northbound                 |      |       |   | Southbound                 |      |       |   | Eastbound                |      |       |   | Westbound                |      |       |   | Total |               |
|                                 | Left                       | Thru | Right | U | Left                       | Thru | Right | U | Left                     | Thru | Right | U | Left                     | Thru | Right | U |       |               |
| All Vehicles                    | 0                          | 0    | 0     | 0 | 0                          | 4    | 124   | 0 | 176                      | 0    | 4     | 0 | 0                        | 0    | 4     | 0 | 312   |               |
| Heavy Trucks                    | 0                          | 0    | 0     | 0 | 0                          | 0    | 0     | 0 | 0                        | 0    | 0     | 0 | 0                        | 0    | 0     | 0 | 0     |               |
| Buses                           |                            |      |       |   |                            |      |       |   |                          |      |       |   |                          |      |       |   |       |               |
| Pedestrians                     |                            | 12   |       |   |                            | 0    |       |   |                          | 0    |       |   |                          | 4    |       |   | 16    |               |
| Bicycles                        | 0                          | 0    | 0     |   | 0                          | 0    | 0     |   | 0                        | 0    | 0     |   | 0                        | 0    | 0     |   | 0     |               |
| Scoters                         |                            |      |       |   |                            |      |       |   |                          |      |       |   |                          |      |       |   |       |               |
| <i>Comments:</i>                |                            |      |       |   |                            |      |       |   |                          |      |       |   |                          |      |       |   |       |               |

Type of peak hour being reported: Intersection Peak

Method for determining peak hour: Total Entering Volume

LOCATION: Cottonwood Dr -- Tamarisk Dr  
 CITY/STATE: North Tustin, CA

QC JOB #: 16966449  
 DATE: Thu, Apr 10 2025

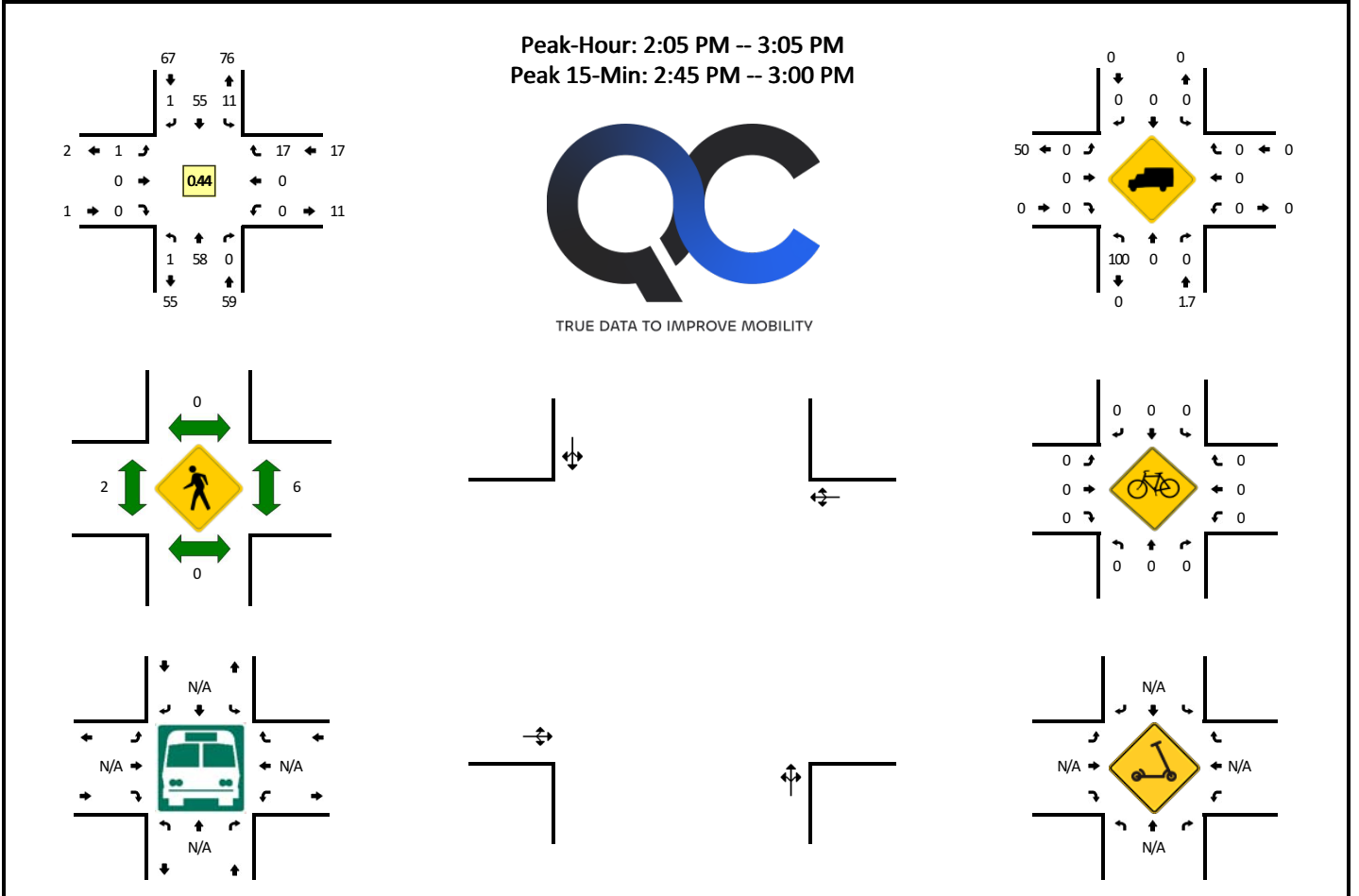

| 5-Min Count Period Beginning At | Cottonwood Dr (Northbound) |      |       |   | Cottonwood Dr (Southbound) |      |       |   | Tamarisk Dr (Eastbound) |      |       |   | Tamarisk Dr (Westbound) |      |       |   | Total | Hourly Totals |
|---------------------------------|----------------------------|------|-------|---|----------------------------|------|-------|---|-------------------------|------|-------|---|-------------------------|------|-------|---|-------|---------------|
|                                 | Left                       | Thru | Right | U | Left                       | Thru | Right | U | Left                    | Thru | Right | U | Left                    | Thru | Right | U |       |               |
| 6:00 AM                         | 0                          | 1    | 0     | 0 | 0                          | 0    | 0     | 0 | 0                       | 0    | 0     | 0 | 0                       | 0    | 0     | 0 | 1     |               |
| 6:05 AM                         | 0                          | 0    | 0     | 0 | 0                          | 0    | 0     | 0 | 0                       | 0    | 0     | 0 | 0                       | 0    | 0     | 1 | 1     |               |
| 6:10 AM                         | 0                          | 1    | 0     | 0 | 0                          | 1    | 0     | 0 | 0                       | 0    | 0     | 0 | 0                       | 0    | 0     | 0 | 2     |               |
| 6:15 AM                         | 0                          | 0    | 0     | 0 | 0                          | 0    | 0     | 0 | 0                       | 0    | 0     | 1 | 0                       | 0    | 0     | 0 | 2     |               |
| 6:20 AM                         | 0                          | 0    | 0     | 0 | 0                          | 0    | 0     | 0 | 0                       | 0    | 0     | 0 | 0                       | 0    | 0     | 0 | 0     |               |
| 6:25 AM                         | 0                          | 0    | 0     | 0 | 0                          | 0    | 0     | 0 | 0                       | 0    | 0     | 0 | 0                       | 1    | 0     | 0 | 1     |               |
| 6:30 AM                         | 0                          | 0    | 0     | 0 | 0                          | 0    | 0     | 0 | 0                       | 0    | 0     | 0 | 0                       | 0    | 0     | 0 | 0     |               |
| 6:35 AM                         | 0                          | 0    | 0     | 0 | 0                          | 0    | 0     | 0 | 0                       | 0    | 0     | 0 | 0                       | 0    | 0     | 0 | 0     |               |
| 6:40 AM                         | 0                          | 0    | 0     | 0 | 0                          | 0    | 0     | 0 | 0                       | 0    | 0     | 0 | 0                       | 0    | 0     | 0 | 0     |               |
| 6:45 AM                         | 0                          | 0    | 0     | 0 | 0                          | 0    | 0     | 0 | 0                       | 0    | 0     | 0 | 0                       | 0    | 1     | 0 | 1     |               |
| 6:50 AM                         | 0                          | 0    | 0     | 0 | 1                          | 0    | 0     | 0 | 0                       | 0    | 0     | 0 | 0                       | 0    | 0     | 0 | 1     |               |
| 6:55 AM                         | 0                          | 0    | 0     | 0 | 0                          | 0    | 0     | 0 | 0                       | 0    | 0     | 0 | 0                       | 0    | 1     | 0 | 1     | 10            |
| 7:00 AM                         | 0                          | 2    | 0     | 0 | 0                          | 0    | 0     | 0 | 0                       | 0    | 0     | 0 | 0                       | 0    | 1     | 0 | 3     | 12            |
| 7:05 AM                         | 0                          | 0    | 0     | 0 | 0                          | 0    | 0     | 0 | 0                       | 0    | 0     | 0 | 0                       | 0    | 0     | 0 | 0     | 11            |
| 7:10 AM                         | 0                          | 1    | 0     | 0 | 0                          | 1    | 0     | 0 | 0                       | 0    | 0     | 0 | 0                       | 0    | 2     | 0 | 4     | 13            |
| 7:15 AM                         | 0                          | 3    | 0     | 0 | 0                          | 2    | 0     | 0 | 0                       | 0    | 0     | 0 | 0                       | 0    | 0     | 0 | 5     | 16            |
| 7:20 AM                         | 0                          | 1    | 0     | 0 | 1                          | 0    | 0     | 0 | 0                       | 0    | 0     | 0 | 0                       | 0    | 0     | 0 | 2     | 18            |
| 7:25 AM                         | 0                          | 2    | 0     | 0 | 0                          | 1    | 0     | 0 | 0                       | 0    | 0     | 0 | 0                       | 0    | 0     | 0 | 3     | 20            |
| 7:30 AM                         | 0                          | 0    | 0     | 0 | 1                          | 0    | 0     | 0 | 0                       | 0    | 0     | 0 | 0                       | 0    | 0     | 0 | 1     | 21            |
| 7:35 AM                         | 0                          | 2    | 0     | 0 | 1                          | 0    | 0     | 0 | 0                       | 0    | 0     | 0 | 0                       | 0    | 1     | 0 | 4     | 25            |
| 7:40 AM                         | 0                          | 1    | 0     | 0 | 1                          | 2    | 0     | 0 | 0                       | 0    | 0     | 0 | 0                       | 0    | 2     | 0 | 6     | 31            |
| 7:45 AM                         | 0                          | 5    | 0     | 0 | 0                          | 2    | 0     | 0 | 0                       | 0    | 0     | 0 | 0                       | 0    | 1     | 0 | 8     | 38            |
| 7:50 AM                         | 0                          | 4    | 0     | 0 | 1                          | 2    | 0     | 0 | 0                       | 0    | 0     | 0 | 0                       | 0    | 0     | 0 | 7     | 44            |
| 7:55 AM                         | 0                          | 4    | 0     | 0 | 0                          | 7    | 0     | 0 | 0                       | 0    | 0     | 0 | 0                       | 0    | 2     | 0 | 13    | 56            |
| 8:00 AM                         | 0                          | 11   | 0     | 0 | 1                          | 14   | 0     | 0 | 0                       | 0    | 0     | 0 | 0                       | 0    | 2     | 0 | 28    | 81            |
| 8:05 AM                         | 0                          | 17   | 0     | 0 | 0                          | 16   | 0     | 0 | 0                       | 0    | 0     | 0 | 0                       | 0    | 1     | 0 | 34    | 115           |
| 8:10 AM                         | 0                          | 19   | 0     | 0 | 0                          | 2    | 0     | 0 | 1                       | 0    | 0     | 0 | 0                       | 0    | 1     | 0 | 23    | 134           |
| 8:15 AM                         | 0                          | 2    | 0     | 0 | 1                          | 4    | 0     | 0 | 0                       | 0    | 0     | 0 | 0                       | 0    | 1     | 0 | 8     | 137           |
| 8:20 AM                         | 0                          | 0    | 0     | 0 | 0                          | 1    | 0     | 0 | 0                       | 0    | 0     | 0 | 0                       | 0    | 1     | 0 | 2     | 137           |
| 8:25 AM                         | 0                          | 3    | 0     | 0 | 1                          | 2    | 0     | 0 | 0                       | 0    | 0     | 0 | 0                       | 0    | 0     | 0 | 6     | 140           |
| 8:30 AM                         | 0                          | 1    | 0     | 0 | 0                          | 2    | 0     | 0 | 0                       | 0    | 0     | 0 | 0                       | 0    | 1     | 0 | 4     | 143           |
| 8:35 AM                         | 0                          | 2    | 0     | 0 | 1                          | 0    | 0     | 0 | 0                       | 0    | 0     | 0 | 0                       | 0    | 0     | 0 | 3     | 142           |
| 8:40 AM                         | 0                          | 0    | 0     | 0 | 0                          | 1    | 0     | 0 | 0                       | 0    | 0     | 0 | 0                       | 0    | 0     | 0 | 1     | 137           |
| 8:45 AM                         | 0                          | 0    | 0     | 0 | 0                          | 1    | 0     | 0 | 0                       | 0    | 0     | 0 | 0                       | 0    | 1     | 0 | 2     | 131           |
| 8:50 AM                         | 0                          | 3    | 0     | 0 | 0                          | 2    | 0     | 0 | 0                       | 0    | 1     | 0 | 0                       | 0    | 0     | 0 | 6     | 130           |
| 8:55 AM                         | 0                          | 1    | 0     | 0 | 0                          | 0    | 0     | 0 | 0                       | 0    | 0     | 0 | 0                       | 0    | 1     | 0 | 2     | 119           |
| 9:00 AM                         | 0                          | 1    | 0     | 0 | 0                          | 0    | 0     | 0 | 0                       | 0    | 0     | 0 | 0                       | 0    | 1     | 0 | 2     | 93            |
| 9:05 AM                         | 0                          | 0    | 0     | 0 | 0                          | 1    | 0     | 0 | 0                       | 0    | 0     | 0 | 0                       | 0    | 0     | 0 | 1     | 60            |

Attachment B

| 5-Min Count Period Beginning At | Cottonwood Dr (Northbound) |      |       |   | Cottonwood Dr (Southbound) |      |       |   | Tamarisk Dr (Eastbound) |      |       |   | Tamarisk Dr (Westbound) |      |       |   | Total | Hourly Totals |
|---------------------------------|----------------------------|------|-------|---|----------------------------|------|-------|---|-------------------------|------|-------|---|-------------------------|------|-------|---|-------|---------------|
|                                 | Left                       | Thru | Right | U | Left                       | Thru | Right | U | Left                    | Thru | Right | U | Left                    | Thru | Right | U |       |               |
| 9:10 AM                         | 0                          | 1    | 0     | 0 | 1                          | 2    | 0     | 0 | 0                       | 0    | 0     | 0 | 0                       | 0    | 0     | 0 | 4     | 41            |
| 9:15 AM                         | 0                          | 0    | 0     | 0 | 1                          | 0    | 0     | 0 | 0                       | 0    | 0     | 0 | 0                       | 0    | 0     | 0 | 1     | 34            |
| 9:20 AM                         | 0                          | 0    | 0     | 0 | 0                          | 0    | 0     | 0 | 0                       | 0    | 0     | 0 | 0                       | 0    | 1     | 0 | 1     | 33            |
| 9:25 AM                         | 0                          | 0    | 0     | 0 | 0                          | 0    | 0     | 0 | 0                       | 0    | 0     | 0 | 0                       | 0    | 0     | 0 | 0     | 27            |
| 9:30 AM                         | 0                          | 0    | 0     | 0 | 0                          | 0    | 0     | 0 | 0                       | 0    | 0     | 0 | 0                       | 0    | 0     | 0 | 0     | 23            |
| 9:35 AM                         | 0                          | 0    | 0     | 0 | 0                          | 0    | 0     | 0 | 0                       | 0    | 0     | 0 | 0                       | 0    | 0     | 0 | 0     | 20            |
| 9:40 AM                         | 0                          | 2    | 0     | 0 | 0                          | 1    | 0     | 0 | 0                       | 0    | 0     | 0 | 0                       | 0    | 0     | 0 | 3     | 22            |
| 9:45 AM                         | 0                          | 2    | 0     | 0 | 0                          | 2    | 0     | 0 | 0                       | 0    | 0     | 0 | 0                       | 0    | 1     | 0 | 5     | 25            |
| 9:50 AM                         | 0                          | 0    | 0     | 0 | 0                          | 0    | 0     | 0 | 0                       | 0    | 0     | 0 | 0                       | 0    | 0     | 0 | 0     | 19            |
| 9:55 AM                         | 0                          | 0    | 0     | 0 | 0                          | 1    | 0     | 0 | 0                       | 0    | 0     | 0 | 0                       | 0    | 0     | 0 | 1     | 18            |
| 10:00 AM                        | 0                          | 1    | 0     | 0 | 1                          | 1    | 0     | 0 | 0                       | 0    | 0     | 0 | 0                       | 1    | 0     | 0 | 4     | 20            |
| 10:05 AM                        | 0                          | 0    | 0     | 0 | 0                          | 1    | 0     | 0 | 0                       | 0    | 0     | 0 | 0                       | 0    | 1     | 0 | 2     | 21            |
| 10:10 AM                        | 0                          | 0    | 0     | 0 | 0                          | 1    | 0     | 0 | 0                       | 0    | 0     | 0 | 0                       | 0    | 1     | 0 | 2     | 19            |
| 10:15 AM                        | 0                          | 2    | 0     | 0 | 1                          | 0    | 0     | 0 | 0                       | 0    | 0     | 0 | 0                       | 2    | 0     | 0 | 5     | 23            |
| 10:20 AM                        | 0                          | 0    | 0     | 0 | 0                          | 0    | 0     | 0 | 0                       | 0    | 0     | 0 | 0                       | 0    | 0     | 0 | 0     | 22            |
| 10:25 AM                        | 0                          | 1    | 0     | 0 | 3                          | 0    | 0     | 0 | 0                       | 0    | 0     | 0 | 0                       | 0    | 0     | 0 | 4     | 26            |
| 10:30 AM                        | 0                          | 1    | 0     | 0 | 0                          | 2    | 0     | 0 | 0                       | 0    | 0     | 0 | 0                       | 0    | 0     | 0 | 3     | 29            |
| 10:35 AM                        | 0                          | 2    | 0     | 0 | 0                          | 0    | 0     | 0 | 0                       | 0    | 0     | 0 | 0                       | 0    | 1     | 0 | 3     | 32            |
| 10:40 AM                        | 0                          | 1    | 0     | 0 | 1                          | 3    | 0     | 0 | 0                       | 0    | 0     | 0 | 0                       | 0    | 0     | 0 | 5     | 34            |
| 10:45 AM                        | 0                          | 0    | 1     | 0 | 0                          | 1    | 0     | 0 | 0                       | 0    | 0     | 0 | 0                       | 0    | 1     | 0 | 3     | 32            |
| 10:50 AM                        | 0                          | 2    | 0     | 0 | 0                          | 1    | 0     | 0 | 0                       | 0    | 0     | 0 | 0                       | 0    | 1     | 0 | 4     | 36            |
| 10:55 AM                        | 0                          | 0    | 0     | 0 | 1                          | 1    | 0     | 0 | 0                       | 0    | 0     | 0 | 1                       | 0    | 0     | 0 | 3     | 38            |
| 11:00 AM                        | 0                          | 2    | 0     | 0 | 0                          | 0    | 0     | 0 | 0                       | 0    | 0     | 0 | 0                       | 0    | 0     | 0 | 2     | 36            |
| 11:05 AM                        | 0                          | 0    | 0     | 0 | 2                          | 3    | 0     | 0 | 0                       | 0    | 0     | 0 | 0                       | 0    | 0     | 0 | 5     | 39            |
| 11:10 AM                        | 0                          | 0    | 0     | 0 | 0                          | 1    | 0     | 0 | 0                       | 0    | 0     | 0 | 0                       | 0    | 0     | 0 | 1     | 38            |
| 11:15 AM                        | 0                          | 0    | 0     | 0 | 0                          | 0    | 0     | 0 | 0                       | 0    | 0     | 0 | 0                       | 0    | 0     | 0 | 0     | 33            |
| 11:20 AM                        | 0                          | 2    | 0     | 0 | 1                          | 1    | 0     | 0 | 0                       | 0    | 0     | 0 | 0                       | 0    | 0     | 0 | 4     | 37            |
| 11:25 AM                        | 0                          | 0    | 0     | 0 | 0                          | 3    | 0     | 0 | 0                       | 0    | 0     | 0 | 0                       | 0    | 1     | 0 | 4     | 37            |
| 11:30 AM                        | 0                          | 1    | 0     | 0 | 1                          | 2    | 0     | 0 | 0                       | 0    | 0     | 0 | 0                       | 0    | 0     | 0 | 4     | 38            |
| 11:35 AM                        | 0                          | 0    | 0     | 0 | 1                          | 1    | 0     | 0 | 0                       | 0    | 0     | 0 | 0                       | 0    | 0     | 0 | 2     | 37            |
| 11:40 AM                        | 0                          | 1    | 0     | 0 | 0                          | 1    | 0     | 0 | 0                       | 0    | 0     | 0 | 0                       | 0    | 0     | 0 | 2     | 34            |
| 11:45 AM                        | 0                          | 2    | 0     | 0 | 0                          | 0    | 0     | 0 | 0                       | 0    | 0     | 0 | 0                       | 0    | 0     | 0 | 2     | 33            |
| 11:50 AM                        | 0                          | 3    | 0     | 0 | 1                          | 1    | 0     | 0 | 1                       | 0    | 0     | 0 | 0                       | 0    | 0     | 0 | 6     | 35            |
| 11:55 AM                        | 0                          | 1    | 0     | 0 | 0                          | 0    | 0     | 0 | 0                       | 0    | 0     | 0 | 0                       | 0    | 1     | 0 | 2     | 34            |
| 12:00 PM                        | 0                          | 0    | 0     | 0 | 1                          | 0    | 0     | 0 | 0                       | 0    | 0     | 0 | 0                       | 0    | 1     | 0 | 2     | 34            |
| 12:05 PM                        | 0                          | 2    | 0     | 0 | 1                          | 1    | 0     | 0 | 0                       | 0    | 0     | 0 | 0                       | 0    | 0     | 0 | 4     | 33            |
| 12:10 PM                        | 0                          | 0    | 0     | 0 | 0                          | 3    | 0     | 0 | 0                       | 0    | 0     | 0 | 0                       | 0    | 1     | 0 | 4     | 36            |
| 12:15 PM                        | 0                          | 0    | 0     | 0 | 1                          | 1    | 0     | 0 | 0                       | 0    | 0     | 0 | 0                       | 0    | 0     | 0 | 2     | 38            |
| 12:20 PM                        | 0                          | 2    | 0     | 0 | 0                          | 0    | 0     | 0 | 0                       | 0    | 0     | 0 | 0                       | 0    | 1     | 0 | 3     | 37            |
| 12:25 PM                        | 0                          | 1    | 0     | 0 | 1                          | 0    | 0     | 0 | 0                       | 0    | 0     | 0 | 0                       | 0    | 2     | 0 | 4     | 37            |
| 12:30 PM                        | 0                          | 0    | 0     | 0 | 1                          | 5    | 1     | 0 | 0                       | 0    | 1     | 0 | 0                       | 0    | 0     | 0 | 8     | 41            |
| 12:35 PM                        | 0                          | 0    | 0     | 0 | 0                          | 1    | 0     | 0 | 0                       | 0    | 0     | 0 | 0                       | 0    | 0     | 0 | 1     | 40            |
| 12:40 PM                        | 0                          | 2    | 1     | 0 | 0                          | 0    | 0     | 0 | 0                       | 0    | 0     | 0 | 0                       | 0    | 0     | 0 | 3     | 41            |
| 12:45 PM                        | 0                          | 0    | 0     | 0 | 0                          | 2    | 0     | 0 | 0                       | 0    | 0     | 0 | 0                       | 0    | 1     | 0 | 3     | 42            |
| 12:50 PM                        | 0                          | 1    | 0     | 0 | 0                          | 1    | 0     | 0 | 0                       | 0    | 0     | 0 | 0                       | 0    | 1     | 0 | 3     | 39            |
| 12:55 PM                        | 0                          | 0    | 0     | 0 | 0                          | 1    | 0     | 0 | 1                       | 0    | 0     | 0 | 0                       | 0    | 0     | 0 | 2     | 39            |
| 1:00 PM                         | 0                          | 0    | 0     | 0 | 1                          | 2    | 0     | 0 | 0                       | 0    | 0     | 0 | 0                       | 0    | 0     | 0 | 3     | 40            |
| 1:05 PM                         | 0                          | 2    | 0     | 0 | 0                          | 0    | 0     | 0 | 0                       | 0    | 0     | 0 | 0                       | 0    | 0     | 0 | 2     | 38            |
| 1:10 PM                         | 0                          | 1    | 0     | 0 | 1                          | 1    | 0     | 0 | 0                       | 0    | 0     | 0 | 0                       | 0    | 1     | 0 | 4     | 38            |
| 1:15 PM                         | 0                          | 1    | 0     | 0 | 0                          | 1    | 0     | 0 | 0                       | 0    | 0     | 0 | 0                       | 0    | 1     | 0 | 3     | 39            |
| 1:20 PM                         | 0                          | 0    | 0     | 0 | 1                          | 2    | 0     | 0 | 0                       | 0    | 0     | 0 | 0                       | 0    | 0     | 0 | 3     | 39            |
| 1:25 PM                         | 0                          | 2    | 0     | 0 | 1                          | 0    | 0     | 0 | 0                       | 0    | 0     | 0 | 0                       | 0    | 1     | 0 | 4     | 39            |
| 1:30 PM                         | 0                          | 1    | 0     | 0 | 0                          | 1    | 0     | 0 | 0                       | 0    | 0     | 0 | 0                       | 0    | 0     | 0 | 2     | 33            |
| 1:35 PM                         | 0                          | 0    | 0     | 0 | 0                          | 1    | 0     | 0 | 0                       | 0    | 0     | 0 | 0                       | 0    | 0     | 0 | 1     | 33            |
| 1:40 PM                         | 0                          | 1    | 0     | 0 | 1                          | 0    | 0     | 0 | 0                       | 0    | 0     | 0 | 0                       | 0    | 2     | 0 | 4     | 34            |
| 1:45 PM                         | 0                          | 2    | 0     | 0 | 0                          | 0    | 0     | 0 | 0                       | 0    | 0     | 0 | 0                       | 0    | 0     | 0 | 2     | 33            |
| 1:50 PM                         | 0                          | 1    | 0     | 0 | 0                          | 0    | 0     | 0 | 0                       | 0    | 0     | 0 | 0                       | 0    | 0     | 0 | 1     | 31            |
| 1:55 PM                         | 0                          | 1    | 0     | 0 | 0                          | 1    | 0     | 0 | 0                       | 0    | 0     | 0 | 0                       | 0    | 0     | 0 | 2     | 31            |
| 2:00 PM                         | 0                          | 1    | 0     | 0 | 0                          | 2    | 0     | 0 | 0                       | 0    | 0     | 0 | 0                       | 0    | 0     | 0 | 3     | 31            |
| 2:05 PM                         | 0                          | 2    | 0     | 0 | 0                          | 3    | 0     | 0 | 1                       | 0    | 0     | 0 | 0                       | 0    | 1     | 0 | 7     | 36            |
| 2:10 PM                         | 0                          | 0    | 0     | 0 | 2                          | 2    | 0     | 0 | 0                       | 0    | 0     | 0 | 0                       | 0    | 1     | 0 | 5     | 37            |
| 2:15 PM                         | 0                          | 1    | 0     | 0 | 0                          | 1    | 1     | 0 | 0                       | 0    | 0     | 0 | 0                       | 0    | 1     | 0 | 4     | 38            |
| 2:20 PM                         | 0                          | 2    | 0     | 0 | 1                          | 2    | 0     | 0 | 0                       | 0    | 0     | 0 | 0                       | 0    | 4     | 0 | 9     | 44            |
| 2:25 PM                         | 0                          | 1    | 0     | 0 | 1                          | 4    | 0     | 0 | 0                       | 0    | 0     | 0 | 0                       | 0    | 0     | 0 | 6     | 46            |
| 2:30 PM                         | 0                          | 0    | 0     | 0 | 3                          | 1    | 0     | 0 | 0                       | 0    | 0     | 0 | 0                       | 0    | 4     | 0 | 8     | 52            |
| 2:35 PM                         | 0                          | 2    | 0     | 0 | 0                          | 5    | 0     | 0 | 0                       | 0    | 0     | 0 | 0                       | 0    | 0     | 0 | 7     | 58            |
| 2:40 PM                         | 0                          | 0    | 0     | 0 | 0                          | 5    | 0     | 0 | 0                       | 0    | 0     | 0 | 0                       | 0    | 2     | 0 | 7     | 61            |
| 2:45 PM                         | 0                          | 4    | 0     | 0 | 0                          | 13   | 0     | 0 | 0                       | 0    | 0     | 0 | 0                       | 0    | 1     | 0 | 18    | 77            |
| 2:50 PM                         | 0                          | 30   | 0     | 0 | 2                          | 14   | 0     | 0 | 0                       | 0    | 0     | 0 | 0                       | 0    | 0     | 0 | 46    | 122           |
| 2:55 PM                         | 1                          | 12   | 0     | 0 | 0                          | 3    | 0     | 0 | 0                       | 0    | 0     | 0 | 0                       | 0    | 2     | 0 | 18    | 138           |
| 3:00 PM                         | 0                          | 4    | 0     | 0 | 2                          | 2    | 0     | 0 | 0                       | 0    | 0     | 0 | 0                       | 0    | 1     | 0 | 9     | 144           |
| 3:05 PM                         | 0                          | 1    | 0     | 0 | 2                          | 1    | 0     | 0 | 0                       | 0    | 1     | 0 | 0                       | 0    | 0     | 0 | 5     | 142           |
| 3:10 PM                         | 0                          | 1    | 0     | 0 | 1                          | 2    | 0     | 0 | 0                       | 0    | 0     | 0 | 0                       | 0    | 0     | 0 | 4     | 141           |
| 3:15 PM                         | 0                          | 0    | 0     | 0 | 2                          | 0    | 0     | 0 | 0                       | 0    | 0     | 0 | 0                       | 0    | 0     | 0 | 2     | 139           |
| 3:20 PM                         | 0                          | 2    | 0     | 0 | 0                          | 2    | 0     | 0 | 0                       | 0    | 0     | 0 | 0                       | 0    | 2     | 0 | 6     | 136           |
| 3:25 PM                         | 0                          | 2    | 0     | 0 | 0                          | 1    | 0     | 0 | 0                       | 0    | 0     | 0 | 0                       | 0    | 1     | 0 | 4     | 134           |
| 3:30 PM                         | 0                          | 2    | 0     | 0 | 0                          | 1    | 0     | 0 | 0                       | 0    | 0     | 0 | 0                       | 0    | 1     | 0 | 4     | 130           |
| 3:35 PM                         | 0                          | 0    | 0     | 0 | 0                          | 1    | 0     | 0 | 0                       | 0    | 0     | 0 | 0                       | 0    | 3     | 0 | 4     | 127           |
| 3:40 PM                         | 0                          | 2    | 0     | 0 | 1                          | 0    | 0     | 0 | 0                       | 0    | 0     | 0 | 0                       | 0    | 0     | 0 | 3     | 123           |
| 3:45 PM                         | 0                          | 2    | 0     | 0 | 0                          | 1    | 0     | 0 | 0                       | 0    | 0     | 0 | 0                       | 0    | 4     | 0 | 7     | 112           |
| 3:50 PM                         | 0                          | 0    | 0     | 0 | 2                          | 0    | 0     | 0 | 0                       | 0    | 0     | 0 | 0                       | 0    | 0     | 0 | 2     | 68            |
| 3:55 PM                         | 0                          | 0    | 0     | 0 | 1                          | 0    | 0     | 0 | 0                       | 0    | 0     | 0 | 0                       | 0    | 0     | 0 | 1     | 51            |
| 4:00 PM                         | 0                          | 0    | 0     | 0 | 3                          | 1    | 0     | 0 | 0                       | 0    | 0     | 0 | 0                       | 0    | 0     | 0 | 4     | 46            |
| 4:05 PM                         | 0                          | 0    | 0     | 0 | 2                          | 1    | 0     | 0 | 0                       | 0    | 0     | 0 | 0                       | 0    | 0     | 0 | 3     | 44            |
| 4:10 PM                         | 0                          | 1    | 0     | 0 | 0                          | 2    | 0     | 0 | 0                       | 0    | 0     | 0 | 0                       | 1    | 0     | 0 | 4     | 44            |
| 4:15 PM                         | 0                          | 2    | 0     | 0 | 0                          | 2    | 0     | 0 | 0                       | 0    | 0     | 1 | 0                       | 0    | 0     | 0 | 5     | 47            |
| 4:20 PM                         | 0                          | 1    | 0     | 0 | 0                          | 1    | 0     | 0 | 0                       | 0    | 0     | 0 | 0                       | 1    | 0     | 0 | 3     | 44            |
| 4:25 PM                         | 0                          | 0    | 0     | 0 | 0                          | 3    | 0     | 0 | 0                       | 0    | 0     | 0 | 0                       | 0    | 0     | 0 | 3     | 43            |

**Attachment B**

| 5-Min Count Period Beginning At | Cottonwood Dr (Northbound) |      |       |   | Cottonwood Dr (Southbound) |      |       |   | Tamarisk Dr (Eastbound) |      |       |   | Tamarisk Dr (Westbound) |      |       |   | Total | Hourly Totals |
|---------------------------------|----------------------------|------|-------|---|----------------------------|------|-------|---|-------------------------|------|-------|---|-------------------------|------|-------|---|-------|---------------|
|                                 | Left                       | Thru | Right | U | Left                       | Thru | Right | U | Left                    | Thru | Right | U | Left                    | Thru | Right | U |       |               |
| 4:30 PM                         | 0                          | 1    | 0     | 0 | 0                          | 1    | 0     | 0 | 0                       | 0    | 0     | 0 | 0                       | 0    | 2     | 0 | 4     | 43            |
| 4:35 PM                         | 0                          | 1    | 0     | 0 | 0                          | 3    | 0     | 0 | 0                       | 0    | 0     | 0 | 0                       | 0    | 2     | 0 | 6     | 45            |
| 4:40 PM                         | 0                          | 1    | 0     | 0 | 0                          | 0    | 0     | 0 | 0                       | 0    | 0     | 0 | 0                       | 0    | 2     | 0 | 3     | 45            |
| 4:45 PM                         | 0                          | 0    | 0     | 0 | 0                          | 2    | 0     | 0 | 0                       | 0    | 0     | 0 | 0                       | 0    | 1     | 0 | 3     | 41            |
| 4:50 PM                         | 0                          | 1    | 1     | 0 | 0                          | 0    | 0     | 0 | 0                       | 0    | 0     | 0 | 0                       | 0    | 0     | 0 | 2     | 41            |
| 4:55 PM                         | 0                          | 2    | 0     | 0 | 0                          | 3    | 0     | 0 | 0                       | 0    | 0     | 0 | 0                       | 0    | 0     | 0 | 5     | 45            |
| 5:00 PM                         | 0                          | 1    | 0     | 0 | 1                          | 1    | 2     | 0 | 1                       | 0    | 0     | 0 | 0                       | 0    | 0     | 0 | 6     | 47            |
| 5:05 PM                         | 0                          | 3    | 0     | 0 | 0                          | 0    | 0     | 0 | 0                       | 0    | 0     | 0 | 0                       | 0    | 1     | 0 | 4     | 48            |
| 5:10 PM                         | 0                          | 1    | 0     | 0 | 2                          | 1    | 0     | 0 | 0                       | 0    | 0     | 0 | 0                       | 0    | 0     | 0 | 4     | 48            |
| 5:15 PM                         | 0                          | 2    | 0     | 0 | 0                          | 2    | 0     | 0 | 0                       | 0    | 0     | 0 | 0                       | 0    | 1     | 0 | 5     | 48            |
| 5:20 PM                         | 0                          | 2    | 0     | 0 | 1                          | 0    | 0     | 0 | 0                       | 0    | 0     | 0 | 0                       | 0    | 1     | 0 | 4     | 49            |
| 5:25 PM                         | 0                          | 1    | 0     | 0 | 1                          | 2    | 0     | 0 | 1                       | 0    | 0     | 0 | 0                       | 0    | 1     | 0 | 5     | 51            |
| 5:30 PM                         | 0                          | 1    | 0     | 0 | 1                          | 3    | 0     | 0 | 1                       | 0    | 0     | 0 | 0                       | 0    | 1     | 0 | 7     | 54            |
| 5:35 PM                         | 0                          | 0    | 0     | 0 | 0                          | 0    | 0     | 0 | 0                       | 0    | 0     | 0 | 0                       | 0    | 0     | 0 | 0     | 48            |
| 5:40 PM                         | 0                          | 3    | 0     | 0 | 0                          | 2    | 0     | 0 | 1                       | 0    | 0     | 0 | 0                       | 0    | 0     | 0 | 6     | 51            |
| 5:45 PM                         | 0                          | 0    | 0     | 0 | 1                          | 1    | 0     | 0 | 0                       | 0    | 0     | 0 | 0                       | 0    | 0     | 0 | 2     | 50            |
| 5:50 PM                         | 0                          | 1    | 0     | 0 | 1                          | 1    | 1     | 0 | 0                       | 0    | 0     | 0 | 0                       | 0    | 1     | 0 | 5     | 53            |
| 5:55 PM                         | 0                          | 0    | 0     | 0 | 0                          | 0    | 0     | 0 | 1                       | 0    | 0     | 0 | 0                       | 0    | 1     | 0 | 2     | 50            |
| 6:00 PM                         | 1                          | 0    | 0     | 0 | 0                          | 1    | 0     | 0 | 0                       | 0    | 1     | 0 | 0                       | 0    | 0     | 0 | 3     | 47            |
| 6:05 PM                         | 0                          | 0    | 1     | 0 | 0                          | 6    | 0     | 0 | 0                       | 0    | 0     | 0 | 0                       | 0    | 0     | 0 | 7     | 50            |
| 6:10 PM                         | 0                          | 2    | 0     | 0 | 0                          | 2    | 0     | 0 | 0                       | 0    | 0     | 0 | 0                       | 0    | 0     | 0 | 4     | 50            |
| 6:15 PM                         | 0                          | 0    | 0     | 0 | 0                          | 3    | 1     | 0 | 0                       | 0    | 0     | 0 | 0                       | 0    | 0     | 0 | 4     | 49            |
| 6:20 PM                         | 0                          | 1    | 0     | 0 | 0                          | 2    | 1     | 0 | 0                       | 0    | 0     | 0 | 0                       | 0    | 0     | 0 | 4     | 49            |
| 6:25 PM                         | 0                          | 0    | 0     | 0 | 1                          | 0    | 0     | 0 | 0                       | 0    | 0     | 0 | 1                       | 0    | 0     | 0 | 2     | 46            |
| 6:30 PM                         | 0                          | 0    | 0     | 0 | 0                          | 2    | 0     | 0 | 0                       | 0    | 0     | 0 | 0                       | 0    | 1     | 0 | 3     | 42            |
| 6:35 PM                         | 0                          | 0    | 0     | 0 | 0                          | 4    | 0     | 0 | 0                       | 0    | 0     | 0 | 0                       | 0    | 0     | 0 | 4     | 46            |
| 6:40 PM                         | 0                          | 1    | 0     | 0 | 0                          | 1    | 0     | 0 | 0                       | 0    | 0     | 0 | 0                       | 0    | 1     | 0 | 3     | 43            |
| 6:45 PM                         | 0                          | 0    | 0     | 0 | 0                          | 1    | 0     | 0 | 0                       | 0    | 0     | 0 | 0                       | 0    | 1     | 0 | 2     | 43            |
| 6:50 PM                         | 0                          | 3    | 0     | 0 | 1                          | 0    | 0     | 0 | 0                       | 0    | 0     | 0 | 0                       | 0    | 0     | 0 | 4     | 42            |
| 6:55 PM                         | 0                          | 0    | 0     | 0 | 0                          | 1    | 0     | 0 | 1                       | 0    | 0     | 0 | 0                       | 0    | 0     | 0 | 2     | 42            |
| 7:00 PM                         | 0                          | 0    | 0     | 0 | 1                          | 0    | 0     | 0 | 0                       | 0    | 0     | 0 | 0                       | 0    | 0     | 0 | 1     | 40            |
| 7:05 PM                         | 0                          | 0    | 1     | 0 | 2                          | 1    | 0     | 0 | 0                       | 0    | 0     | 0 | 0                       | 0    | 0     | 0 | 4     | 37            |
| 7:10 PM                         | 0                          | 0    | 0     | 0 | 1                          | 1    | 1     | 0 | 0                       | 0    | 0     | 0 | 0                       | 0    | 0     | 0 | 3     | 36            |
| 7:15 PM                         | 0                          | 0    | 0     | 0 | 2                          | 1    | 0     | 0 | 0                       | 0    | 0     | 0 | 0                       | 0    | 0     | 0 | 3     | 35            |
| 7:20 PM                         | 0                          | 1    | 0     | 0 | 2                          | 0    | 1     | 0 | 0                       | 0    | 0     | 0 | 0                       | 0    | 1     | 0 | 5     | 36            |
| 7:25 PM                         | 0                          | 0    | 0     | 0 | 0                          | 2    | 1     | 0 | 0                       | 0    | 0     | 0 | 0                       | 0    | 0     | 0 | 3     | 37            |
| 7:30 PM                         | 0                          | 1    | 0     | 0 | 0                          | 0    | 0     | 0 | 0                       | 0    | 0     | 0 | 0                       | 0    | 0     | 0 | 1     | 35            |
| 7:35 PM                         | 0                          | 1    | 0     | 0 | 1                          | 0    | 0     | 0 | 0                       | 0    | 0     | 0 | 0                       | 0    | 0     | 0 | 2     | 33            |
| 7:40 PM                         | 0                          | 2    | 0     | 0 | 1                          | 2    | 0     | 0 | 0                       | 0    | 1     | 0 | 0                       | 0    | 0     | 0 | 6     | 36            |
| 7:45 PM                         | 0                          | 1    | 0     | 0 | 1                          | 0    | 0     | 0 | 0                       | 0    | 0     | 0 | 0                       | 0    | 0     | 0 | 2     | 36            |
| 7:50 PM                         | 0                          | 0    | 0     | 0 | 0                          | 0    | 0     | 0 | 0                       | 0    | 0     | 0 | 0                       | 0    | 0     | 0 | 0     | 32            |
| 7:55 PM                         | 0                          | 0    | 0     | 0 | 0                          | 0    | 0     | 0 | 0                       | 0    | 0     | 0 | 0                       | 0    | 0     | 0 | 0     | 30            |
| 8:00 PM                         | 0                          | 1    | 0     | 0 | 0                          | 0    | 0     | 0 | 0                       | 0    | 0     | 0 | 0                       | 0    | 1     | 0 | 2     | 31            |
| 8:05 PM                         | 0                          | 0    | 0     | 0 | 0                          | 0    | 0     | 0 | 1                       | 0    | 0     | 0 | 0                       | 0    | 0     | 0 | 1     | 28            |
| 8:10 PM                         | 0                          | 0    | 0     | 0 | 0                          | 0    | 0     | 0 | 0                       | 0    | 0     | 0 | 0                       | 0    | 0     | 0 | 0     | 25            |
| 8:15 PM                         | 0                          | 2    | 0     | 0 | 0                          | 0    | 1     | 0 | 0                       | 0    | 0     | 0 | 0                       | 0    | 0     | 0 | 3     | 25            |
| 8:20 PM                         | 0                          | 0    | 0     | 0 | 0                          | 0    | 0     | 0 | 1                       | 0    | 0     | 0 | 0                       | 0    | 0     | 0 | 1     | 21            |
| 8:25 PM                         | 0                          | 0    | 0     | 0 | 0                          | 1    | 0     | 0 | 0                       | 0    | 0     | 0 | 0                       | 0    | 0     | 0 | 1     | 19            |
| 8:30 PM                         | 0                          | 0    | 0     | 0 | 0                          | 0    | 1     | 0 | 0                       | 0    | 0     | 0 | 0                       | 0    | 1     | 0 | 2     | 20            |
| 8:35 PM                         | 0                          | 1    | 0     | 0 | 0                          | 0    | 0     | 0 | 0                       | 0    | 0     | 0 | 0                       | 0    | 0     | 0 | 1     | 19            |
| 8:40 PM                         | 0                          | 0    | 0     | 0 | 1                          | 0    | 0     | 0 | 0                       | 0    | 0     | 0 | 0                       | 0    | 0     | 0 | 1     | 14            |
| 8:45 PM                         | 0                          | 1    | 0     | 0 | 0                          | 2    | 0     | 0 | 0                       | 0    | 0     | 0 | 0                       | 0    | 1     | 0 | 4     | 16            |
| 8:50 PM                         | 0                          | 0    | 0     | 0 | 0                          | 1    | 0     | 0 | 0                       | 0    | 0     | 0 | 0                       | 0    | 0     | 0 | 1     | 17            |
| 8:55 PM                         | 0                          | 1    | 0     | 0 | 0                          | 2    | 0     | 0 | 0                       | 0    | 0     | 0 | 0                       | 0    | 0     | 0 | 3     | 20            |
| 9:00 PM                         | 0                          | 0    | 0     | 0 | 1                          | 1    | 0     | 0 | 0                       | 0    | 0     | 0 | 0                       | 0    | 0     | 0 | 2     | 20            |
| 9:05 PM                         | 0                          | 0    | 0     | 0 | 0                          | 0    | 0     | 0 | 0                       | 0    | 0     | 0 | 0                       | 0    | 0     | 0 | 0     | 19            |
| 9:10 PM                         | 0                          | 0    | 0     | 0 | 0                          | 0    | 0     | 0 | 0                       | 0    | 0     | 0 | 0                       | 0    | 0     | 0 | 0     | 19            |
| 9:15 PM                         | 0                          | 0    | 0     | 0 | 0                          | 0    | 0     | 0 | 0                       | 0    | 0     | 0 | 0                       | 0    | 0     | 0 | 0     | 16            |
| 9:20 PM                         | 0                          | 0    | 0     | 0 | 0                          | 0    | 0     | 0 | 0                       | 0    | 0     | 0 | 0                       | 0    | 0     | 0 | 0     | 15            |
| 9:25 PM                         | 0                          | 1    | 0     | 0 | 0                          | 0    | 0     | 0 | 0                       | 0    | 0     | 0 | 0                       | 0    | 0     | 0 | 1     | 15            |
| 9:30 PM                         | 0                          | 1    | 0     | 0 | 0                          | 1    | 0     | 0 | 0                       | 0    | 0     | 0 | 0                       | 0    | 0     | 0 | 2     | 15            |
| 9:35 PM                         | 0                          | 1    | 0     | 0 | 0                          | 2    | 0     | 0 | 0                       | 0    | 0     | 0 | 0                       | 0    | 0     | 0 | 3     | 17            |
| 9:40 PM                         | 0                          | 0    | 0     | 0 | 0                          | 0    | 0     | 0 | 0                       | 0    | 0     | 0 | 0                       | 0    | 0     | 0 | 0     | 16            |
| 9:45 PM                         | 0                          | 1    | 0     | 0 | 0                          | 0    | 0     | 0 | 0                       | 0    | 0     | 0 | 0                       | 0    | 0     | 0 | 1     | 13            |
| 9:50 PM                         | 0                          | 0    | 1     | 0 | 1                          | 0    | 0     | 0 | 0                       | 0    | 0     | 0 | 0                       | 0    | 0     | 0 | 2     | 14            |
| 9:55 PM                         | 0                          | 1    | 0     | 0 | 0                          | 3    | 0     | 0 | 0                       | 0    | 0     | 0 | 0                       | 0    | 0     | 0 | 4     | 15            |
| Peak 15-Min Flowrates           | Northbound                 |      |       |   | Southbound                 |      |       |   | Eastbound               |      |       |   | Westbound               |      |       |   | Total |               |
|                                 | Left                       | Thru | Right | U | Left                       | Thru | Right | U | Left                    | Thru | Right | U | Left                    | Thru | Right | U |       |               |
| All Vehicles                    | 4                          | 184  | 0     | 0 | 8                          | 120  | 0     | 0 | 0                       | 0    | 0     | 0 | 0                       | 0    | 12    | 0 | 328   |               |
| Heavy Trucks                    | 4                          | 0    | 0     | 0 | 0                          | 0    | 0     | 0 | 0                       | 0    | 0     | 0 | 0                       | 0    | 0     | 0 | 4     |               |
| Buses                           |                            | 0    |       |   |                            | 0    |       |   |                         | 4    |       |   |                         | 16   |       |   | 20    |               |
| Pedestrians                     | 0                          | 0    | 0     |   | 0                          | 0    | 0     |   | 0                       | 0    | 0     |   | 0                       | 0    | 0     |   | 0     |               |
| Bicycles                        |                            |      |       |   |                            |      |       |   |                         |      |       |   |                         |      |       |   |       |               |
| Scoters                         |                            |      |       |   |                            |      |       |   |                         |      |       |   |                         |      |       |   |       |               |

*Comments:*  
 Report generated on 4/25/2025 4:03 PM SOURCE: Quality Counts, LLC (<http://www.qualitycounts.net>) 1-877-580-2212

LOCATION: Woodsong -- Greenvale  
 CITY/STATE: Las Flores, CA

QC JOB #: 16966450  
 DATE: Wed, Apr 16 2025

Peak-Hour: 4:50 PM -- 5:50 PM  
 Peak 15-Min: 5:15 PM -- 5:30 PM

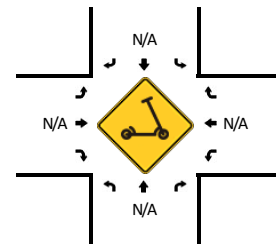
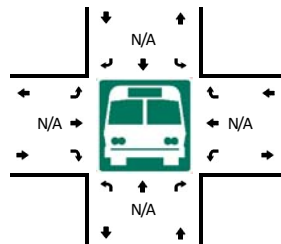
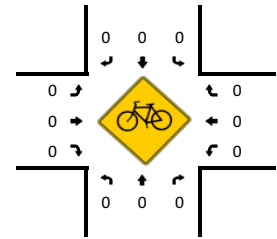
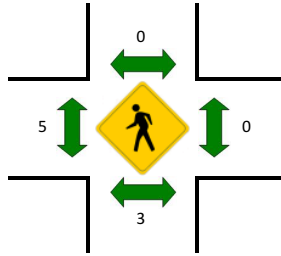
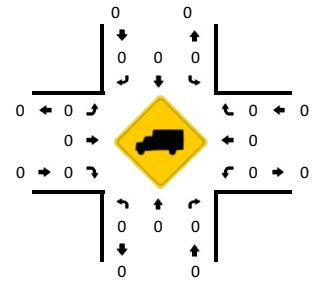
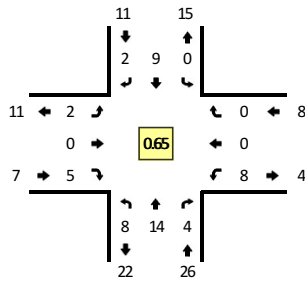

| 5-Min Count Period Beginning At | Woodsong (Northbound) |      |       |   | Woodsong (Southbound) |      |       |   | Greenvale (Eastbound) |      |       |   | Greenvale (Westbound) |      |       |   | Total | Hourly Totals |
|---------------------------------|-----------------------|------|-------|---|-----------------------|------|-------|---|-----------------------|------|-------|---|-----------------------|------|-------|---|-------|---------------|
|                                 | Left                  | Thru | Right | U | Left                  | Thru | Right | U | Left                  | Thru | Right | U | Left                  | Thru | Right | U |       |               |
| 6:00 AM                         | 0                     | 0    | 0     | 0 | 0                     | 2    | 0     | 0 | 0                     | 0    | 0     | 0 | 0                     | 0    | 0     | 0 | 2     |               |
| 6:05 AM                         | 0                     | 0    | 0     | 0 | 0                     | 0    | 0     | 0 | 0                     | 0    | 0     | 1 | 0                     | 0    | 0     | 0 | 1     |               |
| 6:10 AM                         | 0                     | 0    | 0     | 0 | 0                     | 0    | 0     | 0 | 0                     | 0    | 0     | 0 | 0                     | 0    | 0     | 0 | 0     |               |
| 6:15 AM                         | 0                     | 0    | 0     | 0 | 0                     | 0    | 0     | 0 | 0                     | 0    | 0     | 0 | 0                     | 0    | 0     | 0 | 0     |               |
| 6:20 AM                         | 1                     | 0    | 0     | 0 | 0                     | 1    | 0     | 0 | 0                     | 0    | 0     | 1 | 0                     | 0    | 0     | 0 | 3     |               |
| 6:25 AM                         | 0                     | 0    | 0     | 0 | 0                     | 1    | 0     | 0 | 0                     | 0    | 0     | 0 | 0                     | 0    | 0     | 0 | 1     |               |
| 6:30 AM                         | 0                     | 1    | 0     | 0 | 0                     | 1    | 1     | 0 | 0                     | 0    | 0     | 2 | 0                     | 0    | 0     | 0 | 5     |               |
| 6:35 AM                         | 0                     | 0    | 0     | 0 | 0                     | 0    | 0     | 0 | 0                     | 0    | 0     | 0 | 0                     | 0    | 0     | 0 | 0     |               |
| 6:40 AM                         | 0                     | 0    | 0     | 0 | 0                     | 0    | 0     | 0 | 0                     | 0    | 0     | 1 | 0                     | 0    | 0     | 0 | 1     |               |
| 6:45 AM                         | 0                     | 0    | 0     | 0 | 0                     | 0    | 0     | 0 | 0                     | 0    | 0     | 0 | 0                     | 0    | 0     | 0 | 0     |               |
| 6:50 AM                         | 0                     | 0    | 0     | 0 | 0                     | 1    | 0     | 0 | 0                     | 0    | 0     | 1 | 0                     | 0    | 0     | 0 | 2     |               |
| 6:55 AM                         | 1                     | 0    | 0     | 0 | 0                     | 0    | 0     | 0 | 0                     | 0    | 0     | 1 | 0                     | 0    | 0     | 0 | 2     | 17            |
| 7:00 AM                         | 0                     | 0    | 1     | 0 | 0                     | 0    | 0     | 0 | 0                     | 0    | 0     | 0 | 0                     | 0    | 0     | 0 | 1     | 16            |
| 7:05 AM                         | 0                     | 0    | 0     | 0 | 0                     | 0    | 0     | 0 | 0                     | 0    | 0     | 1 | 0                     | 0    | 0     | 0 | 1     | 16            |
| 7:10 AM                         | 0                     | 0    | 0     | 0 | 0                     | 0    | 0     | 0 | 0                     | 0    | 0     | 1 | 0                     | 2    | 0     | 0 | 3     | 19            |
| 7:15 AM                         | 1                     | 0    | 0     | 0 | 0                     | 0    | 0     | 0 | 0                     | 0    | 0     | 0 | 0                     | 0    | 0     | 0 | 1     | 20            |
| 7:20 AM                         | 0                     | 0    | 0     | 1 | 0                     | 2    | 0     | 0 | 0                     | 0    | 0     | 0 | 0                     | 2    | 0     | 0 | 5     | 22            |
| 7:25 AM                         | 0                     | 1    | 0     | 0 | 0                     | 2    | 0     | 0 | 0                     | 0    | 0     | 0 | 0                     | 1    | 0     | 0 | 4     | 25            |
| 7:30 AM                         | 0                     | 0    | 0     | 0 | 0                     | 0    | 0     | 0 | 0                     | 0    | 0     | 0 | 0                     | 0    | 0     | 0 | 0     | 20            |
| 7:35 AM                         | 0                     | 0    | 0     | 0 | 0                     | 1    | 0     | 0 | 0                     | 0    | 0     | 0 | 0                     | 1    | 0     | 0 | 2     | 22            |
| 7:40 AM                         | 0                     | 0    | 0     | 0 | 0                     | 1    | 0     | 0 | 0                     | 0    | 0     | 1 | 0                     | 0    | 0     | 0 | 2     | 23            |
| 7:45 AM                         | 1                     | 1    | 0     | 0 | 0                     | 3    | 0     | 0 | 0                     | 0    | 0     | 0 | 0                     | 1    | 0     | 0 | 6     | 29            |
| 7:50 AM                         | 0                     | 0    | 0     | 0 | 0                     | 0    | 0     | 0 | 0                     | 0    | 0     | 0 | 0                     | 2    | 0     | 0 | 3     | 30            |
| 7:55 AM                         | 0                     | 0    | 0     | 0 | 0                     | 1    | 0     | 0 | 0                     | 0    | 0     | 1 | 0                     | 1    | 0     | 0 | 3     | 31            |
| 8:00 AM                         | 0                     | 1    | 1     | 0 | 0                     | 0    | 0     | 0 | 0                     | 0    | 0     | 1 | 0                     | 3    | 0     | 0 | 6     | 36            |
| 8:05 AM                         | 0                     | 0    | 1     | 0 | 0                     | 0    | 0     | 0 | 0                     | 0    | 0     | 1 | 0                     | 1    | 0     | 0 | 3     | 38            |
| 8:10 AM                         | 0                     | 1    | 0     | 0 | 0                     | 1    | 0     | 0 | 0                     | 0    | 0     | 1 | 0                     | 1    | 0     | 0 | 4     | 39            |
| 8:15 AM                         | 2                     | 0    | 0     | 0 | 0                     | 0    | 0     | 0 | 0                     | 0    | 0     | 0 | 0                     | 1    | 0     | 0 | 3     | 41            |
| 8:20 AM                         | 0                     | 0    | 2     | 0 | 0                     | 0    | 0     | 0 | 0                     | 0    | 0     | 0 | 0                     | 1    | 0     | 0 | 3     | 39            |
| 8:25 AM                         | 0                     | 0    | 0     | 0 | 0                     | 0    | 0     | 0 | 0                     | 0    | 0     | 0 | 0                     | 0    | 0     | 0 | 0     | 35            |
| 8:30 AM                         | 0                     | 0    | 0     | 0 | 0                     | 1    | 0     | 0 | 0                     | 0    | 0     | 1 | 0                     | 0    | 0     | 0 | 2     | 37            |
| 8:35 AM                         | 0                     | 0    | 0     | 0 | 0                     | 2    | 0     | 0 | 0                     | 0    | 0     | 1 | 0                     | 1    | 0     | 0 | 4     | 39            |
| 8:40 AM                         | 0                     | 1    | 0     | 0 | 0                     | 1    | 0     | 0 | 0                     | 0    | 0     | 0 | 0                     | 0    | 0     | 0 | 2     | 39            |
| 8:45 AM                         | 0                     | 0    | 0     | 0 | 0                     | 1    | 0     | 0 | 0                     | 0    | 0     | 1 | 0                     | 0    | 0     | 0 | 2     | 35            |
| 8:50 AM                         | 0                     | 0    | 0     | 0 | 0                     | 0    | 0     | 0 | 0                     | 0    | 0     | 0 | 0                     | 0    | 0     | 0 | 0     | 32            |
| 8:55 AM                         | 0                     | 0    | 3     | 0 | 0                     | 0    | 0     | 0 | 0                     | 0    | 0     | 0 | 0                     | 0    | 0     | 0 | 3     | 32            |
| 9:00 AM                         | 1                     | 1    | 1     | 0 | 0                     | 1    | 0     | 0 | 0                     | 0    | 0     | 0 | 0                     | 0    | 0     | 0 | 4     | 30            |
| 9:05 AM                         | 0                     | 0    | 0     | 0 | 0                     | 1    | 0     | 0 | 0                     | 0    | 0     | 0 | 0                     | 1    | 0     | 0 | 2     | 29            |

### Attachment B

| 5-Min Count<br>Period<br>Beginning At | Woodsong<br>(Northbound) |      |       |   | Woodsong<br>(Southbound) |      |       |   | Greenvale<br>(Eastbound) |      |       |   | Greenvale<br>(Westbound) |      |       |   | Total | Hourly<br>Totals |
|---------------------------------------|--------------------------|------|-------|---|--------------------------|------|-------|---|--------------------------|------|-------|---|--------------------------|------|-------|---|-------|------------------|
|                                       | Left                     | Thru | Right | U | Left                     | Thru | Right | U | Left                     | Thru | Right | U | Left                     | Thru | Right | U |       |                  |
| 9:10 AM                               | 0                        | 1    | 0     | 0 | 0                        | 0    | 0     | 0 | 0                        | 0    | 0     | 0 | 0                        | 0    | 0     | 0 | 1     | 26               |
| 9:15 AM                               | 0                        | 0    | 0     | 0 | 0                        | 0    | 0     | 0 | 0                        | 0    | 0     | 0 | 0                        | 0    | 0     | 0 | 0     | 23               |
| 9:20 AM                               | 0                        | 0    | 0     | 0 | 0                        | 1    | 0     | 0 | 0                        | 0    | 0     | 0 | 0                        | 0    | 0     | 0 | 1     | 21               |
| 9:25 AM                               | 0                        | 0    | 0     | 1 | 0                        | 2    | 0     | 0 | 0                        | 0    | 0     | 0 | 0                        | 0    | 0     | 0 | 3     | 24               |
| 9:30 AM                               | 1                        | 0    | 0     | 0 | 0                        | 1    | 0     | 0 | 0                        | 0    | 0     | 0 | 0                        | 0    | 0     | 0 | 2     | 24               |
| 9:35 AM                               | 0                        | 1    | 0     | 0 | 0                        | 0    | 0     | 0 | 0                        | 0    | 0     | 0 | 0                        | 0    | 0     | 0 | 1     | 21               |
| 9:40 AM                               | 0                        | 0    | 0     | 0 | 0                        | 0    | 0     | 0 | 0                        | 0    | 0     | 0 | 0                        | 0    | 0     | 0 | 0     | 19               |
| 9:45 AM                               | 0                        | 1    | 0     | 0 | 0                        | 0    | 0     | 0 | 0                        | 0    | 0     | 0 | 1                        | 0    | 0     | 0 | 2     | 19               |
| 9:50 AM                               | 0                        | 0    | 0     | 0 | 0                        | 1    | 0     | 0 | 0                        | 0    | 0     | 0 | 0                        | 0    | 0     | 0 | 1     | 20               |
| 9:55 AM                               | 0                        | 0    | 1     | 0 | 0                        | 0    | 0     | 0 | 0                        | 0    | 0     | 0 | 0                        | 0    | 0     | 0 | 1     | 18               |
| 10:00 AM                              | 0                        | 1    | 0     | 0 | 0                        | 0    | 0     | 0 | 0                        | 0    | 2     | 0 | 0                        | 0    | 0     | 0 | 3     | 17               |
| 10:05 AM                              | 0                        | 0    | 0     | 0 | 0                        | 0    | 0     | 0 | 0                        | 0    | 0     | 0 | 0                        | 0    | 0     | 0 | 0     | 15               |
| 10:10 AM                              | 1                        | 0    | 0     | 0 | 0                        | 0    | 0     | 0 | 0                        | 0    | 1     | 0 | 1                        | 0    | 0     | 0 | 3     | 17               |
| 10:15 AM                              | 1                        | 0    | 1     | 0 | 0                        | 0    | 0     | 0 | 0                        | 0    | 0     | 0 | 0                        | 0    | 0     | 0 | 2     | 19               |
| 10:20 AM                              | 0                        | 0    | 1     | 0 | 0                        | 0    | 0     | 0 | 0                        | 0    | 0     | 0 | 1                        | 0    | 0     | 0 | 2     | 20               |
| 10:25 AM                              | 0                        | 0    | 0     | 0 | 0                        | 0    | 1     | 0 | 0                        | 0    | 1     | 0 | 2                        | 0    | 1     | 0 | 5     | 22               |
| 10:30 AM                              | 0                        | 0    | 0     | 0 | 0                        | 0    | 0     | 0 | 0                        | 0    | 0     | 0 | 1                        | 0    | 0     | 0 | 1     | 21               |
| 10:35 AM                              | 0                        | 0    | 0     | 0 | 0                        | 0    | 0     | 0 | 0                        | 0    | 0     | 0 | 0                        | 0    | 0     | 0 | 0     | 20               |
| 10:40 AM                              | 1                        | 0    | 0     | 0 | 0                        | 0    | 0     | 0 | 0                        | 0    | 2     | 0 | 2                        | 0    | 0     | 0 | 5     | 25               |
| 10:45 AM                              | 0                        | 0    | 0     | 0 | 0                        | 0    | 0     | 0 | 0                        | 0    | 1     | 0 | 0                        | 0    | 0     | 0 | 1     | 24               |
| 10:50 AM                              | 0                        | 0    | 0     | 0 | 0                        | 0    | 0     | 0 | 0                        | 0    | 0     | 0 | 0                        | 0    | 0     | 0 | 0     | 23               |
| 10:55 AM                              | 0                        | 0    | 0     | 0 | 0                        | 0    | 0     | 0 | 0                        | 0    | 0     | 0 | 0                        | 0    | 0     | 0 | 0     | 22               |
| 11:00 AM                              | 0                        | 0    | 0     | 0 | 0                        | 0    | 0     | 0 | 0                        | 0    | 0     | 0 | 0                        | 0    | 0     | 0 | 0     | 19               |
| 11:05 AM                              | 0                        | 2    | 1     | 0 | 0                        | 1    | 0     | 0 | 0                        | 0    | 2     | 0 | 0                        | 0    | 0     | 0 | 6     | 25               |
| 11:10 AM                              | 0                        | 1    | 0     | 0 | 0                        | 0    | 0     | 0 | 0                        | 0    | 0     | 0 | 0                        | 0    | 0     | 0 | 1     | 23               |
| 11:15 AM                              | 1                        | 0    | 0     | 0 | 0                        | 0    | 0     | 0 | 0                        | 0    | 1     | 0 | 1                        | 0    | 0     | 0 | 3     | 24               |
| 11:20 AM                              | 0                        | 2    | 0     | 0 | 0                        | 2    | 0     | 0 | 0                        | 0    | 0     | 0 | 0                        | 1    | 0     | 0 | 5     | 27               |
| 11:25 AM                              | 1                        | 0    | 2     | 0 | 0                        | 0    | 0     | 0 | 0                        | 0    | 2     | 0 | 2                        | 0    | 0     | 0 | 7     | 29               |
| 11:30 AM                              | 1                        | 1    | 0     | 0 | 0                        | 0    | 0     | 0 | 0                        | 0    | 0     | 0 | 0                        | 0    | 0     | 0 | 2     | 30               |
| 11:35 AM                              | 0                        | 0    | 0     | 0 | 0                        | 0    | 0     | 0 | 0                        | 0    | 1     | 0 | 1                        | 0    | 0     | 0 | 2     | 32               |
| 11:40 AM                              | 0                        | 0    | 0     | 0 | 0                        | 0    | 0     | 0 | 0                        | 0    | 0     | 0 | 0                        | 0    | 0     | 0 | 0     | 27               |
| 11:45 AM                              | 0                        | 0    | 0     | 0 | 0                        | 0    | 0     | 0 | 0                        | 0    | 0     | 0 | 2                        | 0    | 0     | 0 | 2     | 28               |
| 11:50 AM                              | 0                        | 0    | 0     | 0 | 0                        | 1    | 0     | 0 | 0                        | 0    | 0     | 0 | 0                        | 0    | 0     | 0 | 1     | 29               |
| 11:55 AM                              | 1                        | 0    | 1     | 0 | 0                        | 0    | 0     | 0 | 0                        | 0    | 0     | 0 | 0                        | 0    | 0     | 0 | 2     | 31               |
| 12:00 PM                              | 0                        | 0    | 0     | 0 | 0                        | 1    | 0     | 0 | 0                        | 0    | 1     | 0 | 0                        | 1    | 0     | 0 | 3     | 34               |
| 12:05 PM                              | 0                        | 0    | 0     | 0 | 0                        | 0    | 0     | 0 | 0                        | 0    | 2     | 0 | 0                        | 0    | 0     | 0 | 2     | 30               |
| 12:10 PM                              | 1                        | 0    | 1     | 0 | 0                        | 0    | 0     | 0 | 0                        | 0    | 0     | 0 | 0                        | 0    | 0     | 0 | 2     | 31               |
| 12:15 PM                              | 0                        | 1    | 0     | 0 | 0                        | 0    | 0     | 0 | 0                        | 0    | 0     | 0 | 0                        | 0    | 0     | 0 | 1     | 29               |
| 12:20 PM                              | 0                        | 1    | 0     | 0 | 1                        | 0    | 0     | 0 | 0                        | 0    | 2     | 0 | 1                        | 0    | 0     | 0 | 5     | 29               |
| 12:25 PM                              | 0                        | 1    | 0     | 0 | 0                        | 0    | 0     | 0 | 0                        | 0    | 0     | 0 | 0                        | 0    | 0     | 0 | 1     | 23               |
| 12:30 PM                              | 0                        | 0    | 0     | 0 | 0                        | 0    | 0     | 0 | 0                        | 0    | 1     | 0 | 0                        | 0    | 0     | 0 | 1     | 22               |
| 12:35 PM                              | 0                        | 1    | 0     | 0 | 0                        | 1    | 0     | 0 | 0                        | 0    | 0     | 0 | 0                        | 0    | 0     | 0 | 2     | 22               |
| 12:40 PM                              | 2                        | 0    | 0     | 0 | 0                        | 0    | 0     | 0 | 0                        | 0    | 1     | 0 | 0                        | 0    | 0     | 0 | 3     | 25               |
| 12:45 PM                              | 1                        | 1    | 0     | 0 | 0                        | 0    | 0     | 0 | 0                        | 0    | 0     | 0 | 1                        | 0    | 0     | 0 | 3     | 26               |
| 12:50 PM                              | 0                        | 1    | 0     | 0 | 0                        | 0    | 0     | 0 | 0                        | 0    | 0     | 0 | 1                        | 0    | 0     | 0 | 2     | 27               |
| 12:55 PM                              | 0                        | 0    | 1     | 0 | 0                        | 0    | 0     | 0 | 0                        | 0    | 1     | 0 | 0                        | 0    | 0     | 0 | 2     | 27               |
| 1:00 PM                               | 1                        | 0    | 0     | 0 | 0                        | 0    | 0     | 0 | 0                        | 0    | 2     | 0 | 1                        | 0    | 0     | 0 | 4     | 28               |
| 1:05 PM                               | 0                        | 1    | 2     | 0 | 0                        | 1    | 0     | 0 | 0                        | 0    | 1     | 0 | 0                        | 0    | 0     | 0 | 5     | 31               |
| 1:10 PM                               | 1                        | 0    | 0     | 0 | 0                        | 0    | 0     | 0 | 0                        | 0    | 0     | 0 | 0                        | 0    | 0     | 0 | 1     | 30               |
| 1:15 PM                               | 1                        | 0    | 2     | 0 | 0                        | 1    | 0     | 0 | 0                        | 0    | 2     | 0 | 1                        | 0    | 0     | 0 | 7     | 36               |
| 1:20 PM                               | 1                        | 1    | 0     | 0 | 0                        | 0    | 0     | 0 | 0                        | 0    | 1     | 0 | 0                        | 0    | 0     | 0 | 3     | 34               |
| 1:25 PM                               | 1                        | 0    | 0     | 0 | 0                        | 0    | 0     | 0 | 0                        | 0    | 1     | 0 | 1                        | 0    | 0     | 0 | 3     | 36               |
| 1:30 PM                               | 1                        | 0    | 1     | 0 | 0                        | 0    | 0     | 0 | 0                        | 0    | 1     | 0 | 0                        | 0    | 0     | 0 | 3     | 38               |
| 1:35 PM                               | 1                        | 0    | 1     | 0 | 0                        | 0    | 0     | 0 | 0                        | 0    | 1     | 0 | 2                        | 0    | 0     | 0 | 5     | 41               |
| 1:40 PM                               | 1                        | 0    | 0     | 0 | 0                        | 2    | 0     | 0 | 0                        | 0    | 1     | 0 | 0                        | 0    | 0     | 0 | 4     | 42               |
| 1:45 PM                               | 1                        | 1    | 3     | 0 | 0                        | 0    | 0     | 0 | 0                        | 0    | 1     | 0 | 0                        | 0    | 0     | 0 | 6     | 45               |
| 1:50 PM                               | 0                        | 0    | 1     | 0 | 0                        | 1    | 0     | 0 | 0                        | 0    | 2     | 0 | 2                        | 0    | 0     | 0 | 6     | 49               |
| 1:55 PM                               | 1                        | 1    | 1     | 0 | 0                        | 1    | 0     | 0 | 0                        | 0    | 0     | 0 | 0                        | 0    | 0     | 0 | 4     | 51               |
| 2:00 PM                               | 0                        | 0    | 1     | 0 | 0                        | 0    | 0     | 0 | 0                        | 0    | 0     | 0 | 0                        | 0    | 0     | 0 | 1     | 48               |
| 2:05 PM                               | 2                        | 0    | 0     | 0 | 0                        | 0    | 0     | 0 | 0                        | 0    | 1     | 0 | 0                        | 0    | 0     | 0 | 3     | 46               |
| 2:10 PM                               | 0                        | 1    | 1     | 0 | 0                        | 0    | 0     | 0 | 0                        | 0    | 1     | 0 | 0                        | 0    | 0     | 0 | 3     | 48               |
| 2:15 PM                               | 1                        | 1    | 0     | 0 | 0                        | 0    | 0     | 0 | 0                        | 0    | 0     | 0 | 0                        | 0    | 0     | 0 | 2     | 43               |
| 2:20 PM                               | 0                        | 0    | 1     | 0 | 0                        | 0    | 0     | 0 | 0                        | 0    | 0     | 0 | 0                        | 1    | 0     | 0 | 2     | 42               |
| 2:25 PM                               | 2                        | 1    | 0     | 0 | 0                        | 1    | 0     | 0 | 0                        | 0    | 0     | 0 | 0                        | 0    | 0     | 0 | 4     | 43               |
| 2:30 PM                               | 1                        | 0    | 0     | 0 | 0                        | 0    | 0     | 0 | 0                        | 0    | 0     | 0 | 0                        | 0    | 0     | 0 | 1     | 41               |
| 2:35 PM                               | 1                        | 0    | 0     | 0 | 0                        | 0    | 0     | 0 | 0                        | 0    | 0     | 0 | 0                        | 0    | 0     | 0 | 1     | 37               |
| 2:40 PM                               | 0                        | 1    | 0     | 0 | 0                        | 1    | 0     | 0 | 0                        | 0    | 0     | 0 | 0                        | 0    | 0     | 0 | 2     | 35               |
| 2:45 PM                               | 0                        | 0    | 1     | 0 | 0                        | 3    | 0     | 0 | 0                        | 0    | 0     | 0 | 0                        | 0    | 0     | 0 | 4     | 33               |
| 2:50 PM                               | 0                        | 0    | 0     | 0 | 0                        | 0    | 0     | 0 | 0                        | 0    | 0     | 0 | 0                        | 0    | 0     | 0 | 0     | 27               |
| 2:55 PM                               | 0                        | 0    | 1     | 0 | 0                        | 1    | 0     | 0 | 0                        | 0    | 0     | 0 | 1                        | 1    | 0     | 0 | 4     | 27               |
| 3:00 PM                               | 0                        | 0    | 1     | 0 | 0                        | 0    | 0     | 0 | 0                        | 1    | 0     | 0 | 0                        | 1    | 0     | 0 | 3     | 29               |
| 3:05 PM                               | 0                        | 1    | 1     | 0 | 0                        | 1    | 0     | 0 | 0                        | 1    | 0     | 0 | 0                        | 0    | 0     | 0 | 4     | 30               |
| 3:10 PM                               | 0                        | 2    | 0     | 0 | 1                        | 0    | 0     | 0 | 0                        | 0    | 3     | 0 | 2                        | 0    | 0     | 0 | 8     | 35               |
| 3:15 PM                               | 0                        | 0    | 0     | 1 | 0                        | 1    | 0     | 0 | 0                        | 0    | 0     | 0 | 0                        | 0    | 0     | 0 | 2     | 35               |
| 3:20 PM                               | 1                        | 0    | 0     | 0 | 0                        | 2    | 0     | 0 | 0                        | 0    | 1     | 0 | 0                        | 0    | 0     | 0 | 4     | 37               |
| 3:25 PM                               | 0                        | 1    | 0     | 0 | 0                        | 1    | 0     | 0 | 0                        | 0    | 0     | 0 | 1                        | 0    | 0     | 0 | 3     | 36               |
| 3:30 PM                               | 2                        | 0    | 0     | 0 | 0                        | 0    | 0     | 0 | 0                        | 0    | 1     | 0 | 0                        | 0    | 0     | 0 | 3     | 38               |
| 3:35 PM                               | 1                        | 1    | 1     | 0 | 0                        | 0    | 0     | 0 | 0                        | 0    | 0     | 0 | 0                        | 0    | 0     | 0 | 3     | 40               |
| 3:40 PM                               | 1                        | 0    | 0     | 0 | 0                        | 0    | 0     | 0 | 0                        | 0    | 0     | 0 | 2                        | 0    | 0     | 0 | 3     | 41               |
| 3:45 PM                               | 1                        | 0    | 0     | 1 | 0                        | 0    | 0     | 0 | 0                        | 0    | 0     | 0 | 1                        | 0    | 0     | 0 | 3     | 40               |
| 3:50 PM                               | 0                        | 0    | 0     | 0 | 0                        | 0    | 0     | 0 | 0                        | 0    | 0     | 0 | 0                        | 0    | 0     | 0 | 0     | 40               |
| 3:55 PM                               | 2                        | 0    | 1     | 0 | 0                        | 1    | 0     | 0 | 0                        | 0    | 0     | 0 | 0                        | 0    | 0     | 0 | 4     | 40               |
| 4:00 PM                               | 0                        | 1    | 0     | 0 | 0                        | 0    | 0     | 0 | 0                        | 0    | 0     | 0 | 1                        | 0    | 0     | 0 | 2     | 39               |
| 4:05 PM                               | 2                        | 0    | 0     | 0 | 0                        | 0    | 0     | 0 | 0                        | 0    | 1     | 0 | 0                        | 0    | 0     | 0 | 3     | 38               |
| 4:10 PM                               | 1                        | 0    | 0     | 0 | 0                        | 0    | 0     | 0 | 0                        | 0    | 0     | 0 | 0                        | 0    | 0     | 0 | 1     | 31               |
| 4:15 PM                               | 1                        | 1    | 2     | 0 | 0                        | 0    | 0     | 0 | 0                        | 0    | 0     | 0 | 0                        | 0    | 0     | 0 | 4     | 33               |
| 4:20 PM                               | 1                        | 0    | 0     | 0 | 0                        | 0    | 0     | 0 | 0                        | 0    | 0     | 0 | 0                        | 0    | 0     | 0 | 1     | 30               |
| 4:25 PM                               | 0                        | 1    | 0     | 1 | 0                        | 0    | 0     | 0 | 0                        | 0    | 0     | 0 | 0                        | 0    | 0     | 0 | 2     | 29               |
| 4:30 PM                               | 0                        | 2    | 0     | 0 | 0                        | 0    | 0     | 0 | 0                        | 0    | 0     | 0 | 0                        | 0    | 0     | 0 | 2     | 28               |

### Attachment B

| 5-Min Count Period Beginning At | Woodsong (Northbound) |      |       |   | Woodsong (Southbound) |      |       |   | Greenvale (Eastbound) |      |       |   | Greenvale (Westbound) |      |       |   | Total | Hourly Totals |
|---------------------------------|-----------------------|------|-------|---|-----------------------|------|-------|---|-----------------------|------|-------|---|-----------------------|------|-------|---|-------|---------------|
|                                 | Left                  | Thru | Right | U | Left                  | Thru | Right | U | Left                  | Thru | Right | U | Left                  | Thru | Right | U |       |               |
| 4:35 PM                         | 0                     | 0    | 1     | 0 | 0                     | 0    | 1     | 0 | 0                     | 0    | 1     | 0 | 0                     | 0    | 0     | 0 | 3     | 28            |
| 4:40 PM                         | 1                     | 2    | 0     | 0 | 0                     | 1    | 0     | 0 | 0                     | 0    | 1     | 0 | 0                     | 0    | 0     | 0 | 5     | 30            |
| 4:45 PM                         | 0                     | 0    | 1     | 0 | 0                     | 1    | 0     | 0 | 0                     | 0    | 1     | 0 | 0                     | 0    | 0     | 0 | 3     | 30            |
| 4:50 PM                         | 0                     | 2    | 0     | 0 | 0                     | 0    | 0     | 0 | 0                     | 0    | 1     | 0 | 1                     | 0    | 0     | 0 | 4     | 34            |
| 4:55 PM                         | 1                     | 0    | 0     | 0 | 0                     | 1    | 0     | 0 | 0                     | 0    | 1     | 0 | 0                     | 0    | 0     | 0 | 3     | 33            |
| 5:00 PM                         | 0                     | 1    | 1     | 0 | 0                     | 1    | 0     | 0 | 0                     | 0    | 0     | 0 | 1                     | 0    | 0     | 0 | 4     | 35            |
| 5:05 PM                         | 0                     | 2    | 0     | 0 | 0                     | 0    | 0     | 0 | 0                     | 0    | 0     | 0 | 0                     | 0    | 0     | 0 | 2     | 34            |
| 5:10 PM                         | 0                     | 1    | 0     | 0 | 0                     | 1    | 0     | 0 | 0                     | 0    | 1     | 0 | 0                     | 0    | 0     | 0 | 3     | 36            |
| 5:15 PM                         | 2                     | 3    | 0     | 0 | 0                     | 0    | 2     | 0 | 1                     | 0    | 0     | 1 | 0                     | 0    | 0     | 0 | 9     | 41            |
| 5:20 PM                         | 0                     | 2    | 0     | 0 | 0                     | 1    | 0     | 0 | 0                     | 0    | 1     | 0 | 1                     | 0    | 0     | 0 | 5     | 45            |
| 5:25 PM                         | 1                     | 1    | 0     | 0 | 0                     | 2    | 0     | 0 | 0                     | 0    | 0     | 0 | 2                     | 0    | 0     | 0 | 6     | 49            |
| 5:30 PM                         | 0                     | 0    | 0     | 0 | 0                     | 2    | 0     | 0 | 0                     | 0    | 0     | 0 | 2                     | 0    | 0     | 0 | 4     | 51            |
| 5:35 PM                         | 0                     | 2    | 1     | 0 | 0                     | 0    | 0     | 0 | 0                     | 0    | 0     | 0 | 0                     | 0    | 0     | 0 | 3     | 51            |
| 5:40 PM                         | 1                     | 0    | 1     | 0 | 0                     | 1    | 0     | 0 | 0                     | 0    | 0     | 0 | 1                     | 0    | 0     | 0 | 4     | 50            |
| 5:45 PM                         | 3                     | 0    | 1     | 0 | 0                     | 0    | 0     | 0 | 0                     | 0    | 1     | 0 | 0                     | 0    | 0     | 0 | 5     | 52            |
| 5:50 PM                         | 0                     | 0    | 0     | 0 | 0                     | 0    | 0     | 0 | 0                     | 0    | 1     | 0 | 1                     | 0    | 0     | 0 | 2     | 50            |
| 5:55 PM                         | 0                     | 0    | 0     | 0 | 0                     | 0    | 0     | 0 | 0                     | 0    | 1     | 0 | 0                     | 0    | 0     | 0 | 1     | 48            |
| 6:00 PM                         | 2                     | 2    | 0     | 0 | 0                     | 1    | 0     | 0 | 0                     | 0    | 0     | 0 | 0                     | 0    | 0     | 0 | 5     | 49            |
| 6:05 PM                         | 1                     | 0    | 1     | 0 | 0                     | 0    | 0     | 0 | 0                     | 0    | 1     | 0 | 0                     | 0    | 0     | 0 | 3     | 50            |
| 6:10 PM                         | 0                     | 0    | 0     | 0 | 0                     | 0    | 0     | 0 | 0                     | 0    | 0     | 0 | 0                     | 0    | 0     | 0 | 0     | 47            |
| 6:15 PM                         | 0                     | 1    | 0     | 0 | 0                     | 0    | 0     | 0 | 0                     | 0    | 1     | 0 | 0                     | 0    | 0     | 0 | 2     | 40            |
| 6:20 PM                         | 0                     | 0    | 0     | 0 | 0                     | 0    | 0     | 0 | 0                     | 0    | 0     | 0 | 0                     | 0    | 0     | 0 | 0     | 35            |
| 6:25 PM                         | 0                     | 1    | 0     | 0 | 0                     | 1    | 0     | 0 | 0                     | 0    | 0     | 0 | 0                     | 0    | 0     | 0 | 2     | 31            |
| 6:30 PM                         | 2                     | 0    | 0     | 0 | 0                     | 0    | 0     | 0 | 0                     | 0    | 1     | 0 | 0                     | 0    | 0     | 0 | 3     | 30            |
| 6:35 PM                         | 0                     | 1    | 0     | 0 | 0                     | 0    | 0     | 0 | 0                     | 0    | 1     | 0 | 0                     | 0    | 0     | 0 | 2     | 29            |
| 6:40 PM                         | 1                     | 1    | 0     | 0 | 0                     | 0    | 0     | 0 | 0                     | 0    | 1     | 0 | 1                     | 0    | 0     | 0 | 4     | 29            |
| 6:45 PM                         | 0                     | 1    | 0     | 0 | 0                     | 0    | 0     | 0 | 0                     | 0    | 0     | 0 | 0                     | 0    | 0     | 0 | 1     | 25            |
| 6:50 PM                         | 2                     | 2    | 1     | 0 | 0                     | 1    | 0     | 0 | 0                     | 0    | 1     | 0 | 0                     | 0    | 0     | 0 | 7     | 30            |
| 6:55 PM                         | 0                     | 0    | 0     | 0 | 0                     | 0    | 0     | 0 | 0                     | 0    | 2     | 0 | 0                     | 0    | 0     | 0 | 2     | 31            |
| 7:00 PM                         | 1                     | 0    | 0     | 0 | 0                     | 0    | 0     | 0 | 0                     | 0    | 0     | 0 | 0                     | 0    | 0     | 0 | 1     | 27            |
| 7:05 PM                         | 0                     | 0    | 0     | 0 | 0                     | 0    | 0     | 0 | 0                     | 0    | 0     | 0 | 0                     | 0    | 0     | 0 | 0     | 24            |
| 7:10 PM                         | 1                     | 0    | 1     | 0 | 0                     | 1    | 0     | 0 | 0                     | 0    | 0     | 0 | 0                     | 0    | 0     | 0 | 3     | 27            |
| 7:15 PM                         | 0                     | 1    | 0     | 0 | 0                     | 0    | 0     | 0 | 0                     | 0    | 0     | 0 | 0                     | 0    | 0     | 0 | 1     | 26            |
| 7:20 PM                         | 0                     | 2    | 0     | 0 | 0                     | 0    | 0     | 0 | 0                     | 0    | 0     | 0 | 0                     | 0    | 0     | 0 | 2     | 28            |
| 7:25 PM                         | 1                     | 2    | 2     | 0 | 0                     | 0    | 0     | 0 | 0                     | 0    | 0     | 0 | 0                     | 0    | 0     | 0 | 5     | 31            |
| 7:30 PM                         | 1                     | 1    | 0     | 0 | 0                     | 0    | 0     | 0 | 0                     | 0    | 1     | 0 | 0                     | 0    | 0     | 0 | 3     | 31            |
| 7:35 PM                         | 1                     | 0    | 2     | 0 | 0                     | 0    | 0     | 0 | 0                     | 0    | 0     | 0 | 0                     | 0    | 0     | 0 | 3     | 32            |
| 7:40 PM                         | 0                     | 0    | 1     | 0 | 0                     | 0    | 0     | 0 | 0                     | 0    | 0     | 0 | 0                     | 0    | 0     | 0 | 1     | 29            |
| 7:45 PM                         | 0                     | 0    | 0     | 0 | 0                     | 0    | 0     | 0 | 0                     | 0    | 0     | 0 | 0                     | 0    | 0     | 0 | 0     | 28            |
| 7:50 PM                         | 0                     | 2    | 0     | 0 | 0                     | 0    | 0     | 0 | 0                     | 0    | 0     | 0 | 0                     | 0    | 0     | 0 | 2     | 23            |
| 7:55 PM                         | 0                     | 0    | 0     | 0 | 0                     | 0    | 0     | 0 | 0                     | 0    | 0     | 0 | 1                     | 0    | 0     | 0 | 1     | 22            |
| 8:00 PM                         | 0                     | 0    | 0     | 0 | 0                     | 1    | 0     | 0 | 0                     | 0    | 0     | 0 | 0                     | 0    | 0     | 0 | 1     | 22            |
| 8:05 PM                         | 2                     | 1    | 0     | 0 | 0                     | 0    | 0     | 0 | 0                     | 0    | 0     | 0 | 0                     | 0    | 0     | 0 | 3     | 25            |
| 8:10 PM                         | 0                     | 0    | 0     | 0 | 0                     | 0    | 0     | 0 | 0                     | 0    | 0     | 0 | 0                     | 0    | 0     | 0 | 0     | 22            |
| 8:15 PM                         | 0                     | 1    | 0     | 0 | 0                     | 0    | 0     | 0 | 0                     | 0    | 0     | 0 | 0                     | 0    | 0     | 0 | 1     | 22            |
| 8:20 PM                         | 0                     | 0    | 0     | 0 | 0                     | 1    | 0     | 0 | 0                     | 0    | 1     | 0 | 0                     | 0    | 0     | 0 | 2     | 22            |
| 8:25 PM                         | 0                     | 0    | 1     | 0 | 0                     | 0    | 0     | 0 | 0                     | 0    | 0     | 0 | 0                     | 0    | 0     | 0 | 1     | 18            |
| 8:30 PM                         | 0                     | 0    | 0     | 0 | 0                     | 0    | 0     | 0 | 0                     | 0    | 0     | 0 | 1                     | 0    | 0     | 0 | 1     | 16            |
| 8:35 PM                         | 0                     | 0    | 0     | 0 | 0                     | 0    | 0     | 0 | 0                     | 0    | 0     | 0 | 0                     | 0    | 0     | 0 | 0     | 13            |
| 8:40 PM                         | 1                     | 1    | 0     | 0 | 0                     | 0    | 0     | 0 | 0                     | 0    | 0     | 0 | 0                     | 0    | 0     | 0 | 2     | 14            |
| 8:45 PM                         | 0                     | 0    | 0     | 0 | 0                     | 0    | 0     | 0 | 0                     | 0    | 0     | 0 | 0                     | 0    | 0     | 0 | 0     | 14            |
| 8:50 PM                         | 0                     | 0    | 1     | 0 | 0                     | 0    | 0     | 0 | 0                     | 0    | 0     | 0 | 1                     | 0    | 0     | 0 | 2     | 14            |
| 8:55 PM                         | 0                     | 0    | 0     | 0 | 0                     | 0    | 0     | 0 | 0                     | 0    | 0     | 0 | 0                     | 0    | 0     | 0 | 0     | 13            |
| 9:00 PM                         | 1                     | 0    | 0     | 0 | 0                     | 0    | 0     | 0 | 0                     | 0    | 1     | 0 | 0                     | 0    | 0     | 0 | 2     | 14            |
| 9:05 PM                         | 0                     | 0    | 0     | 0 | 0                     | 0    | 0     | 0 | 0                     | 0    | 0     | 0 | 0                     | 2    | 0     | 0 | 2     | 13            |
| 9:10 PM                         | 0                     | 1    | 0     | 0 | 0                     | 0    | 0     | 0 | 0                     | 0    | 0     | 0 | 0                     | 0    | 0     | 0 | 1     | 14            |
| 9:15 PM                         | 0                     | 0    | 1     | 0 | 0                     | 1    | 0     | 0 | 0                     | 0    | 0     | 0 | 0                     | 0    | 0     | 0 | 2     | 15            |
| 9:20 PM                         | 0                     | 0    | 0     | 0 | 0                     | 0    | 0     | 0 | 0                     | 0    | 0     | 0 | 0                     | 0    | 0     | 0 | 0     | 13            |
| 9:25 PM                         | 0                     | 1    | 0     | 0 | 0                     | 0    | 0     | 0 | 0                     | 0    | 0     | 0 | 0                     | 0    | 0     | 0 | 1     | 13            |
| 9:30 PM                         | 0                     | 0    | 0     | 0 | 0                     | 0    | 0     | 0 | 0                     | 0    | 1     | 0 | 0                     | 0    | 0     | 0 | 1     | 13            |
| 9:35 PM                         | 0                     | 0    | 1     | 0 | 0                     | 0    | 0     | 0 | 0                     | 0    | 0     | 0 | 0                     | 0    | 0     | 0 | 1     | 14            |
| 9:40 PM                         | 0                     | 0    | 0     | 0 | 0                     | 0    | 0     | 0 | 0                     | 0    | 0     | 0 | 0                     | 0    | 0     | 0 | 0     | 12            |
| 9:45 PM                         | 0                     | 0    | 0     | 0 | 0                     | 0    | 0     | 0 | 0                     | 0    | 0     | 0 | 0                     | 0    | 0     | 0 | 0     | 12            |
| 9:50 PM                         | 0                     | 0    | 0     | 0 | 0                     | 0    | 0     | 0 | 0                     | 0    | 0     | 0 | 0                     | 0    | 0     | 0 | 0     | 10            |
| 9:55 PM                         | 0                     | 0    | 0     | 0 | 0                     | 0    | 0     | 0 | 0                     | 0    | 0     | 0 | 0                     | 0    | 0     | 0 | 0     | 10            |
| Peak 15-Min Flowrates           | Northbound            |      |       |   | Southbound            |      |       |   | Eastbound             |      |       |   | Westbound             |      |       |   | Total |               |
|                                 | Left                  | Thru | Right | U | Left                  | Thru | Right | U | Left                  | Thru | Right | U | Left                  | Thru | Right | U |       |               |
| All Vehicles                    | 12                    | 24   | 0     | 0 | 0                     | 12   | 8     | 0 | 4                     | 0    | 4     | 4 | 12                    | 0    | 0     | 0 | 80    |               |
| Heavy Trucks                    | 0                     | 0    | 0     | 0 | 0                     | 0    | 0     | 0 | 0                     | 0    | 0     | 0 | 0                     | 0    | 0     | 0 | 0     |               |
| Buses                           |                       |      |       |   |                       |      |       |   |                       |      |       |   |                       |      |       |   |       |               |
| Pedestrians                     |                       | 8    |       |   |                       | 0    |       |   |                       | 8    |       |   |                       | 0    |       |   | 16    |               |
| Bicycles                        | 0                     | 0    | 0     |   | 0                     | 0    | 0     |   | 0                     | 0    | 0     |   | 0                     | 0    | 0     |   | 0     |               |
| Scoters                         |                       |      |       |   |                       |      |       |   |                       |      |       |   |                       |      |       |   |       |               |

Comments: Report generated on 4/25/2025 4:03 PM SOURCE: Quality Counts, LLC (<http://www.qualitycounts.net>) 1-877-580-2212

LOCATION: Meadowood -- Greenvale  
 CITY/STATE: Las Flores, CA

QC JOB #: 16966451  
 DATE: Wed, Apr 16 2025

Peak-Hour: 7:25 AM -- 8:25 AM  
 Peak 15-Min: 8:00 AM -- 8:15 AM

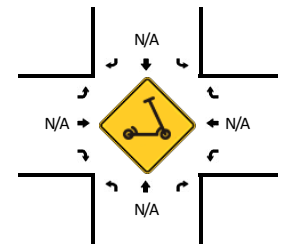
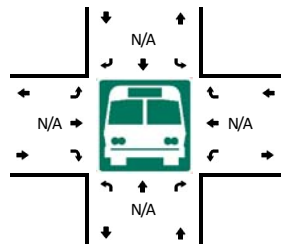
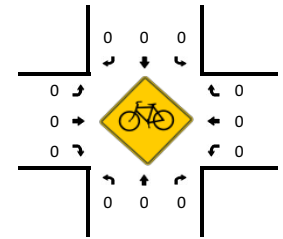
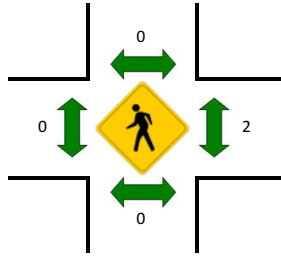
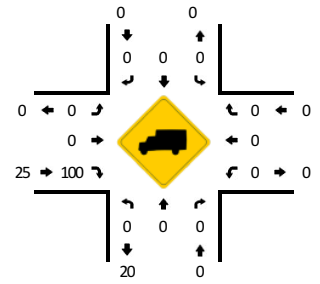
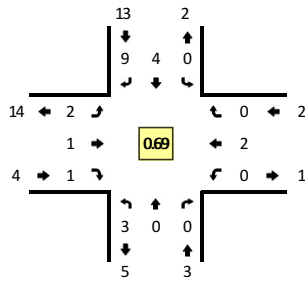

| 5-Min Count Period Beginning At | Meadowood (Northbound) |      |       |   | Meadowood (Southbound) |      |       |   | Greenvale (Eastbound) |      |       |   | Greenvale (Westbound) |      |       |   | Total | Hourly Totals |    |
|---------------------------------|------------------------|------|-------|---|------------------------|------|-------|---|-----------------------|------|-------|---|-----------------------|------|-------|---|-------|---------------|----|
|                                 | Left                   | Thru | Right | U | Left                   | Thru | Right | U | Left                  | Thru | Right | U | Left                  | Thru | Right | U |       |               |    |
| 6:00 AM                         | 0                      | 0    | 0     | 0 | 0                      | 0    | 0     | 0 | 0                     | 0    | 0     | 0 | 0                     | 0    | 0     | 0 | 0     | 0             |    |
| 6:05 AM                         | 0                      | 0    | 0     | 0 | 0                      | 0    | 0     | 0 | 0                     | 0    | 0     | 0 | 0                     | 0    | 0     | 0 | 0     | 0             |    |
| 6:10 AM                         | 0                      | 0    | 0     | 0 | 0                      | 0    | 0     | 0 | 0                     | 0    | 0     | 0 | 0                     | 0    | 0     | 0 | 0     | 0             |    |
| 6:15 AM                         | 0                      | 0    | 0     | 0 | 0                      | 0    | 0     | 0 | 0                     | 0    | 0     | 0 | 0                     | 0    | 0     | 0 | 0     | 0             |    |
| 6:20 AM                         | 0                      | 0    | 0     | 0 | 0                      | 0    | 0     | 0 | 0                     | 0    | 0     | 0 | 0                     | 0    | 0     | 0 | 0     | 0             |    |
| 6:25 AM                         | 0                      | 0    | 0     | 0 | 0                      | 0    | 0     | 0 | 0                     | 0    | 0     | 0 | 0                     | 0    | 0     | 0 | 0     | 0             |    |
| 6:30 AM                         | 0                      | 0    | 0     | 0 | 0                      | 0    | 0     | 0 | 0                     | 0    | 0     | 0 | 0                     | 0    | 0     | 0 | 0     | 0             |    |
| 6:35 AM                         | 0                      | 0    | 0     | 0 | 0                      | 0    | 0     | 0 | 0                     | 0    | 0     | 0 | 0                     | 0    | 0     | 0 | 0     | 0             |    |
| 6:40 AM                         | 0                      | 0    | 0     | 0 | 0                      | 0    | 0     | 0 | 0                     | 0    | 0     | 0 | 0                     | 0    | 0     | 0 | 0     | 0             |    |
| 6:45 AM                         | 0                      | 0    | 0     | 0 | 0                      | 0    | 0     | 0 | 0                     | 0    | 0     | 0 | 0                     | 0    | 0     | 0 | 0     | 0             |    |
| 6:50 AM                         | 0                      | 0    | 0     | 0 | 0                      | 0    | 0     | 0 | 0                     | 0    | 0     | 0 | 0                     | 0    | 0     | 0 | 0     | 0             |    |
| 6:55 AM                         | 0                      | 0    | 0     | 0 | 0                      | 0    | 0     | 0 | 0                     | 0    | 0     | 0 | 0                     | 0    | 0     | 0 | 0     | 0             | 0  |
| 7:00 AM                         | 0                      | 0    | 0     | 0 | 0                      | 0    | 0     | 0 | 0                     | 1    | 0     | 0 | 0                     | 0    | 0     | 0 | 0     | 1             | 1  |
| 7:05 AM                         | 0                      | 0    | 0     | 0 | 0                      | 0    | 0     | 0 | 0                     | 0    | 0     | 0 | 0                     | 0    | 0     | 0 | 0     | 0             | 1  |
| 7:10 AM                         | 0                      | 0    | 0     | 0 | 0                      | 0    | 1     | 0 | 0                     | 0    | 0     | 0 | 0                     | 1    | 0     | 0 | 0     | 2             | 3  |
| 7:15 AM                         | 0                      | 0    | 0     | 0 | 0                      | 0    | 0     | 0 | 0                     | 0    | 0     | 0 | 0                     | 0    | 0     | 0 | 0     | 0             | 3  |
| 7:20 AM                         | 1                      | 0    | 0     | 0 | 0                      | 0    | 1     | 0 | 0                     | 0    | 0     | 0 | 0                     | 0    | 0     | 0 | 0     | 2             | 5  |
| 7:25 AM                         | 1                      | 0    | 0     | 0 | 0                      | 1    | 0     | 0 | 0                     | 0    | 0     | 0 | 0                     | 0    | 0     | 0 | 0     | 2             | 7  |
| 7:30 AM                         | 0                      | 0    | 0     | 0 | 0                      | 0    | 0     | 0 | 0                     | 0    | 0     | 0 | 0                     | 0    | 0     | 0 | 0     | 0             | 7  |
| 7:35 AM                         | 0                      | 0    | 0     | 0 | 0                      | 0    | 1     | 0 | 0                     | 0    | 0     | 0 | 0                     | 0    | 0     | 0 | 0     | 1             | 8  |
| 7:40 AM                         | 0                      | 0    | 0     | 0 | 0                      | 0    | 0     | 0 | 0                     | 0    | 0     | 0 | 0                     | 0    | 0     | 0 | 0     | 0             | 8  |
| 7:45 AM                         | 0                      | 0    | 0     | 0 | 0                      | 2    | 1     | 0 | 0                     | 0    | 0     | 0 | 0                     | 0    | 0     | 0 | 0     | 3             | 11 |
| 7:50 AM                         | 1                      | 0    | 0     | 0 | 0                      | 0    | 1     | 0 | 0                     | 0    | 0     | 0 | 0                     | 1    | 0     | 0 | 0     | 3             | 14 |
| 7:55 AM                         | 0                      | 0    | 0     | 0 | 0                      | 0    | 0     | 0 | 0                     | 0    | 0     | 0 | 0                     | 0    | 0     | 0 | 0     | 0             | 14 |
| 8:00 AM                         | 0                      | 0    | 0     | 0 | 0                      | 0    | 3     | 0 | 0                     | 1    | 0     | 0 | 0                     | 0    | 0     | 0 | 0     | 4             | 17 |
| 8:05 AM                         | 1                      | 0    | 0     | 0 | 0                      | 0    | 1     | 0 | 0                     | 1    | 0     | 0 | 0                     | 0    | 0     | 0 | 0     | 3             | 20 |
| 8:10 AM                         | 0                      | 0    | 0     | 0 | 0                      | 0    | 1     | 0 | 0                     | 0    | 0     | 0 | 0                     | 0    | 0     | 0 | 0     | 1             | 19 |
| 8:15 AM                         | 0                      | 0    | 0     | 0 | 0                      | 0    | 0     | 0 | 0                     | 0    | 0     | 0 | 0                     | 1    | 0     | 0 | 0     | 1             | 20 |
| 8:20 AM                         | 0                      | 0    | 0     | 0 | 0                      | 1    | 1     | 0 | 0                     | 1    | 0     | 1 | 0                     | 0    | 0     | 0 | 0     | 4             | 22 |
| 8:25 AM                         | 0                      | 0    | 0     | 0 | 0                      | 0    | 0     | 0 | 0                     | 0    | 0     | 0 | 0                     | 0    | 0     | 0 | 0     | 0             | 20 |
| 8:30 AM                         | 0                      | 0    | 0     | 0 | 0                      | 0    | 0     | 0 | 0                     | 0    | 0     | 0 | 0                     | 0    | 0     | 0 | 0     | 0             | 20 |
| 8:35 AM                         | 0                      | 0    | 0     | 0 | 0                      | 1    | 0     | 0 | 0                     | 0    | 0     | 0 | 0                     | 1    | 0     | 0 | 0     | 2             | 21 |
| 8:40 AM                         | 0                      | 0    | 0     | 0 | 0                      | 0    | 0     | 0 | 0                     | 0    | 0     | 0 | 0                     | 0    | 0     | 0 | 0     | 0             | 21 |
| 8:45 AM                         | 0                      | 0    | 0     | 0 | 0                      | 0    | 0     | 0 | 0                     | 0    | 0     | 0 | 0                     | 0    | 0     | 0 | 0     | 0             | 18 |
| 8:50 AM                         | 0                      | 0    | 0     | 0 | 0                      | 0    | 0     | 0 | 0                     | 0    | 0     | 0 | 0                     | 0    | 0     | 0 | 0     | 0             | 15 |
| 8:55 AM                         | 0                      | 0    | 0     | 0 | 0                      | 0    | 0     | 0 | 0                     | 2    | 0     | 1 | 0                     | 0    | 0     | 0 | 0     | 3             | 18 |
| 9:00 AM                         | 0                      | 0    | 0     | 0 | 0                      | 0    | 0     | 0 | 0                     | 1    | 0     | 0 | 0                     | 0    | 0     | 0 | 0     | 1             | 15 |
| 9:05 AM                         | 0                      | 0    | 0     | 0 | 0                      | 0    | 1     | 0 | 0                     | 0    | 0     | 0 | 0                     | 0    | 0     | 0 | 0     | 1             | 13 |

**Attachment B**

| 5-Min Count Period Beginning At | Meadowood (Northbound) |      |       |   | Meadowood (Southbound) |      |       |   | Greenvale (Eastbound) |      |       |   | Greenvale (Westbound) |      |       |   | Total | Hourly Totals |    |
|---------------------------------|------------------------|------|-------|---|------------------------|------|-------|---|-----------------------|------|-------|---|-----------------------|------|-------|---|-------|---------------|----|
|                                 | Left                   | Thru | Right | U | Left                   | Thru | Right | U | Left                  | Thru | Right | U | Left                  | Thru | Right | U |       |               |    |
| 9:10 AM                         | 0                      | 0    | 0     | 0 | 0                      | 0    | 0     | 0 | 0                     | 0    | 0     | 0 | 0                     | 0    | 0     | 0 | 0     | 0             | 12 |
| 9:15 AM                         | 0                      | 0    | 0     | 0 | 0                      | 0    | 0     | 0 | 0                     | 0    | 0     | 0 | 0                     | 0    | 0     | 0 | 0     | 0             | 11 |
| 9:20 AM                         | 0                      | 0    | 0     | 0 | 0                      | 0    | 0     | 0 | 0                     | 0    | 0     | 0 | 0                     | 0    | 0     | 0 | 0     | 0             | 7  |
| 9:25 AM                         | 0                      | 0    | 0     | 0 | 0                      | 0    | 0     | 0 | 0                     | 0    | 0     | 0 | 0                     | 0    | 0     | 0 | 0     | 0             | 7  |
| 9:30 AM                         | 0                      | 0    | 0     | 0 | 0                      | 0    | 0     | 0 | 0                     | 0    | 0     | 0 | 1                     | 0    | 0     | 0 | 0     | 1             | 8  |
| 9:35 AM                         | 0                      | 0    | 0     | 0 | 0                      | 0    | 0     | 0 | 0                     | 0    | 0     | 0 | 0                     | 0    | 0     | 0 | 0     | 0             | 6  |
| 9:40 AM                         | 0                      | 0    | 0     | 0 | 0                      | 0    | 0     | 0 | 0                     | 0    | 0     | 0 | 0                     | 0    | 0     | 0 | 0     | 0             | 6  |
| 9:45 AM                         | 0                      | 0    | 0     | 0 | 0                      | 1    | 0     | 0 | 0                     | 0    | 0     | 0 | 0                     | 1    | 0     | 0 | 0     | 2             | 8  |
| 9:50 AM                         | 0                      | 0    | 0     | 0 | 0                      | 0    | 0     | 0 | 0                     | 0    | 0     | 0 | 0                     | 0    | 0     | 0 | 0     | 0             | 8  |
| 9:55 AM                         | 0                      | 0    | 0     | 0 | 0                      | 0    | 0     | 0 | 1                     | 0    | 0     | 0 | 0                     | 0    | 0     | 0 | 0     | 1             | 6  |
| 10:00 AM                        | 0                      | 0    | 0     | 0 | 0                      | 0    | 0     | 0 | 0                     | 0    | 0     | 0 | 0                     | 0    | 0     | 0 | 0     | 0             | 5  |
| 10:05 AM                        | 0                      | 0    | 0     | 0 | 0                      | 0    | 0     | 0 | 0                     | 0    | 0     | 0 | 0                     | 0    | 0     | 0 | 0     | 0             | 4  |
| 10:10 AM                        | 0                      | 0    | 0     | 0 | 0                      | 0    | 1     | 0 | 0                     | 0    | 0     | 0 | 0                     | 0    | 0     | 0 | 0     | 1             | 5  |
| 10:15 AM                        | 0                      | 0    | 0     | 0 | 0                      | 0    | 0     | 0 | 1                     | 0    | 0     | 0 | 0                     | 0    | 0     | 0 | 0     | 1             | 6  |
| 10:20 AM                        | 0                      | 0    | 2     | 0 | 0                      | 0    | 1     | 0 | 0                     | 0    | 1     | 0 | 0                     | 1    | 1     | 0 | 0     | 6             | 12 |
| 10:25 AM                        | 1                      | 0    | 0     | 0 | 0                      | 0    | 1     | 0 | 0                     | 0    | 0     | 0 | 0                     | 0    | 0     | 0 | 0     | 2             | 14 |
| 10:30 AM                        | 0                      | 0    | 0     | 0 | 0                      | 0    | 1     | 0 | 0                     | 0    | 0     | 0 | 0                     | 0    | 0     | 0 | 0     | 1             | 14 |
| 10:35 AM                        | 0                      | 1    | 0     | 0 | 0                      | 0    | 0     | 0 | 0                     | 0    | 0     | 0 | 0                     | 0    | 0     | 0 | 0     | 1             | 15 |
| 10:40 AM                        | 1                      | 1    | 0     | 0 | 0                      | 0    | 1     | 0 | 0                     | 0    | 0     | 0 | 0                     | 0    | 0     | 0 | 0     | 3             | 18 |
| 10:45 AM                        | 0                      | 0    | 0     | 0 | 0                      | 0    | 0     | 0 | 0                     | 0    | 0     | 0 | 0                     | 0    | 0     | 0 | 0     | 0             | 16 |
| 10:50 AM                        | 0                      | 0    | 0     | 0 | 0                      | 0    | 0     | 0 | 0                     | 0    | 0     | 0 | 0                     | 0    | 0     | 0 | 0     | 0             | 16 |
| 10:55 AM                        | 0                      | 0    | 0     | 0 | 0                      | 0    | 0     | 0 | 0                     | 0    | 0     | 0 | 0                     | 0    | 0     | 0 | 0     | 0             | 15 |
| 11:00 AM                        | 0                      | 0    | 0     | 0 | 0                      | 0    | 0     | 0 | 0                     | 0    | 0     | 0 | 0                     | 0    | 0     | 0 | 0     | 0             | 15 |
| 11:05 AM                        | 0                      | 1    | 0     | 0 | 0                      | 0    | 0     | 0 | 0                     | 1    | 0     | 0 | 0                     | 0    | 0     | 0 | 0     | 2             | 17 |
| 11:10 AM                        | 0                      | 0    | 0     | 0 | 0                      | 0    | 0     | 0 | 0                     | 0    | 0     | 0 | 0                     | 0    | 0     | 0 | 0     | 0             | 16 |
| 11:15 AM                        | 0                      | 0    | 0     | 0 | 0                      | 0    | 1     | 0 | 0                     | 0    | 0     | 0 | 0                     | 0    | 0     | 0 | 0     | 1             | 16 |
| 11:20 AM                        | 0                      | 1    | 0     | 0 | 1                      | 0    | 0     | 0 | 0                     | 0    | 0     | 0 | 0                     | 1    | 0     | 0 | 0     | 3             | 13 |
| 11:25 AM                        | 0                      | 1    | 0     | 0 | 0                      | 0    | 1     | 0 | 1                     | 0    | 1     | 0 | 0                     | 1    | 0     | 0 | 0     | 5             | 16 |
| 11:30 AM                        | 0                      | 0    | 0     | 0 | 0                      | 0    | 0     | 0 | 0                     | 0    | 0     | 0 | 0                     | 0    | 0     | 0 | 0     | 0             | 15 |
| 11:35 AM                        | 0                      | 0    | 0     | 0 | 0                      | 0    | 0     | 0 | 0                     | 0    | 0     | 0 | 0                     | 1    | 0     | 0 | 0     | 1             | 15 |
| 11:40 AM                        | 0                      | 0    | 0     | 0 | 0                      | 0    | 0     | 0 | 0                     | 0    | 0     | 0 | 0                     | 0    | 0     | 0 | 0     | 0             | 12 |
| 11:45 AM                        | 0                      | 0    | 0     | 0 | 0                      | 0    | 1     | 0 | 0                     | 0    | 0     | 0 | 0                     | 1    | 0     | 0 | 0     | 2             | 14 |
| 11:50 AM                        | 0                      | 0    | 0     | 0 | 0                      | 0    | 0     | 0 | 0                     | 0    | 0     | 0 | 0                     | 0    | 0     | 0 | 0     | 0             | 14 |
| 11:55 AM                        | 0                      | 1    | 0     | 0 | 0                      | 0    | 0     | 0 | 0                     | 1    | 0     | 0 | 0                     | 0    | 0     | 0 | 0     | 2             | 16 |
| 12:00 PM                        | 0                      | 0    | 0     | 0 | 0                      | 0    | 1     | 0 | 0                     | 0    | 0     | 0 | 0                     | 0    | 0     | 0 | 0     | 1             | 17 |
| 12:05 PM                        | 0                      | 0    | 0     | 0 | 0                      | 0    | 0     | 0 | 0                     | 0    | 0     | 0 | 0                     | 0    | 0     | 0 | 0     | 0             | 15 |
| 12:10 PM                        | 0                      | 0    | 0     | 0 | 0                      | 0    | 0     | 0 | 1                     | 0    | 0     | 0 | 0                     | 0    | 0     | 0 | 0     | 1             | 16 |
| 12:15 PM                        | 0                      | 0    | 0     | 0 | 0                      | 0    | 0     | 0 | 0                     | 0    | 0     | 0 | 0                     | 0    | 0     | 0 | 0     | 0             | 15 |
| 12:20 PM                        | 0                      | 0    | 0     | 0 | 0                      | 0    | 1     | 0 | 0                     | 1    | 0     | 0 | 0                     | 0    | 1     | 0 | 0     | 3             | 15 |
| 12:25 PM                        | 0                      | 1    | 0     | 0 | 0                      | 0    | 0     | 0 | 0                     | 0    | 0     | 0 | 0                     | 0    | 0     | 0 | 0     | 1             | 11 |
| 12:30 PM                        | 0                      | 0    | 0     | 0 | 0                      | 0    | 0     | 0 | 0                     | 0    | 0     | 0 | 0                     | 0    | 0     | 0 | 0     | 0             | 11 |
| 12:35 PM                        | 0                      | 0    | 0     | 0 | 0                      | 0    | 0     | 0 | 0                     | 0    | 0     | 0 | 0                     | 0    | 0     | 0 | 0     | 0             | 10 |
| 12:40 PM                        | 0                      | 0    | 0     | 0 | 0                      | 0    | 0     | 0 | 0                     | 0    | 0     | 0 | 0                     | 0    | 0     | 0 | 0     | 0             | 10 |
| 12:45 PM                        | 0                      | 0    | 0     | 0 | 0                      | 0    | 1     | 0 | 0                     | 0    | 0     | 0 | 1                     | 0    | 0     | 0 | 0     | 2             | 10 |
| 12:50 PM                        | 0                      | 0    | 0     | 0 | 0                      | 0    | 0     | 0 | 0                     | 0    | 0     | 0 | 0                     | 1    | 0     | 0 | 0     | 1             | 11 |
| 12:55 PM                        | 0                      | 0    | 0     | 0 | 0                      | 0    | 0     | 0 | 0                     | 0    | 1     | 0 | 0                     | 0    | 0     | 0 | 0     | 1             | 10 |
| 1:00 PM                         | 0                      | 2    | 0     | 0 | 0                      | 0    | 1     | 0 | 0                     | 0    | 0     | 0 | 0                     | 0    | 0     | 0 | 0     | 3             | 12 |
| 1:05 PM                         | 0                      | 0    | 0     | 0 | 0                      | 0    | 0     | 0 | 2                     | 0    | 0     | 0 | 0                     | 0    | 0     | 0 | 0     | 2             | 14 |
| 1:10 PM                         | 0                      | 1    | 0     | 0 | 0                      | 0    | 0     | 0 | 0                     | 0    | 0     | 0 | 0                     | 0    | 0     | 0 | 0     | 1             | 14 |
| 1:15 PM                         | 0                      | 0    | 0     | 0 | 0                      | 0    | 1     | 0 | 1                     | 0    | 1     | 0 | 0                     | 0    | 0     | 0 | 0     | 3             | 17 |
| 1:20 PM                         | 0                      | 0    | 0     | 0 | 0                      | 0    | 0     | 0 | 0                     | 0    | 0     | 0 | 0                     | 0    | 0     | 0 | 0     | 0             | 14 |
| 1:25 PM                         | 0                      | 0    | 0     | 0 | 0                      | 1    | 1     | 0 | 0                     | 0    | 0     | 0 | 0                     | 0    | 0     | 0 | 0     | 2             | 15 |
| 1:30 PM                         | 0                      | 0    | 0     | 0 | 0                      | 0    | 0     | 0 | 1                     | 0    | 0     | 0 | 0                     | 0    | 0     | 0 | 0     | 1             | 16 |
| 1:35 PM                         | 0                      | 0    | 0     | 0 | 0                      | 0    | 2     | 0 | 1                     | 0    | 0     | 0 | 0                     | 0    | 0     | 0 | 0     | 3             | 19 |
| 1:40 PM                         | 0                      | 0    | 0     | 0 | 0                      | 0    | 0     | 0 | 0                     | 0    | 0     | 0 | 0                     | 0    | 0     | 0 | 0     | 0             | 19 |
| 1:45 PM                         | 0                      | 0    | 0     | 0 | 0                      | 0    | 0     | 0 | 2                     | 0    | 1     | 0 | 0                     | 0    | 0     | 0 | 0     | 3             | 20 |
| 1:50 PM                         | 0                      | 0    | 0     | 0 | 0                      | 0    | 2     | 0 | 0                     | 0    | 1     | 0 | 0                     | 0    | 0     | 0 | 0     | 3             | 22 |
| 1:55 PM                         | 0                      | 0    | 0     | 0 | 0                      | 0    | 0     | 0 | 1                     | 0    | 0     | 0 | 0                     | 0    | 0     | 0 | 0     | 1             | 22 |
| 2:00 PM                         | 0                      | 0    | 0     | 0 | 0                      | 2    | 0     | 0 | 0                     | 0    | 1     | 0 | 0                     | 0    | 0     | 0 | 0     | 3             | 22 |
| 2:05 PM                         | 0                      | 0    | 0     | 0 | 0                      | 0    | 0     | 0 | 0                     | 0    | 0     | 0 | 0                     | 0    | 0     | 0 | 0     | 0             | 20 |
| 2:10 PM                         | 0                      | 0    | 0     | 0 | 0                      | 0    | 0     | 0 | 0                     | 1    | 0     | 0 | 0                     | 0    | 0     | 0 | 0     | 1             | 20 |
| 2:15 PM                         | 0                      | 0    | 0     | 0 | 0                      | 0    | 0     | 0 | 0                     | 0    | 0     | 0 | 0                     | 0    | 0     | 0 | 0     | 0             | 17 |
| 2:20 PM                         | 1                      | 0    | 0     | 0 | 0                      | 0    | 0     | 0 | 1                     | 0    | 0     | 0 | 0                     | 0    | 0     | 0 | 0     | 2             | 19 |
| 2:25 PM                         | 0                      | 0    | 0     | 0 | 0                      | 0    | 0     | 0 | 0                     | 0    | 0     | 0 | 0                     | 0    | 0     | 0 | 0     | 0             | 17 |
| 2:30 PM                         | 0                      | 0    | 0     | 0 | 0                      | 0    | 0     | 0 | 0                     | 0    | 0     | 0 | 0                     | 0    | 0     | 0 | 0     | 0             | 16 |
| 2:35 PM                         | 0                      | 0    | 0     | 0 | 0                      | 0    | 0     | 0 | 0                     | 0    | 0     | 0 | 0                     | 0    | 0     | 0 | 0     | 0             | 13 |
| 2:40 PM                         | 0                      | 0    | 0     | 0 | 0                      | 0    | 0     | 0 | 0                     | 0    | 0     | 0 | 0                     | 0    | 0     | 0 | 0     | 0             | 13 |
| 2:45 PM                         | 0                      | 1    | 0     | 0 | 0                      | 0    | 0     | 0 | 1                     | 0    | 0     | 0 | 0                     | 0    | 0     | 0 | 0     | 2             | 12 |
| 2:50 PM                         | 0                      | 0    | 2     | 0 | 0                      | 0    | 0     | 0 | 0                     | 0    | 0     | 0 | 1                     | 0    | 1     | 0 | 0     | 4             | 13 |
| 2:55 PM                         | 0                      | 1    | 0     | 0 | 0                      | 0    | 2     | 0 | 0                     | 1    | 0     | 0 | 0                     | 0    | 0     | 0 | 0     | 4             | 16 |
| 3:00 PM                         | 0                      | 0    | 0     | 0 | 1                      | 0    | 0     | 0 | 1                     | 0    | 0     | 0 | 0                     | 1    | 0     | 0 | 0     | 3             | 16 |
| 3:05 PM                         | 0                      | 0    | 0     | 0 | 0                      | 0    | 0     | 0 | 1                     | 0    | 0     | 0 | 0                     | 0    | 0     | 0 | 0     | 1             | 17 |
| 3:10 PM                         | 0                      | 0    | 0     | 0 | 0                      | 0    | 2     | 0 | 0                     | 0    | 1     | 0 | 0                     | 0    | 0     | 0 | 0     | 3             | 19 |
| 3:15 PM                         | 0                      | 1    | 0     | 0 | 0                      | 0    | 0     | 0 | 0                     | 0    | 0     | 0 | 0                     | 0    | 0     | 0 | 0     | 1             | 20 |
| 3:20 PM                         | 0                      | 0    | 0     | 0 | 0                      | 0    | 0     | 0 | 0                     | 0    | 0     | 0 | 0                     | 0    | 0     | 0 | 0     | 0             | 18 |
| 3:25 PM                         | 0                      | 0    | 0     | 0 | 0                      | 0    | 1     | 0 | 0                     | 0    | 0     | 0 | 0                     | 0    | 0     | 0 | 0     | 1             | 19 |
| 3:30 PM                         | 0                      | 0    | 0     | 0 | 0                      | 0    | 0     | 0 | 0                     | 0    | 0     | 0 | 0                     | 0    | 0     | 0 | 0     | 0             | 19 |
| 3:35 PM                         | 0                      | 0    | 0     | 0 | 0                      | 0    | 0     | 0 | 0                     | 0    | 1     | 0 | 0                     | 0    | 0     | 0 | 0     | 1             | 20 |
| 3:40 PM                         | 1                      | 0    | 0     | 0 | 0                      | 0    | 0     | 0 | 0                     | 0    | 0     | 0 | 0                     | 0    | 0     | 0 | 0     | 1             | 21 |
| 3:45 PM                         | 0                      | 0    | 0     | 0 | 0                      | 0    | 0     | 0 | 0                     | 0    | 0     | 0 | 0                     | 1    | 0     | 0 | 0     | 1             | 20 |
| 3:50 PM                         | 0                      | 0    | 0     | 0 | 0                      | 0    | 0     | 0 | 0                     | 0    | 0     | 0 | 0                     | 0    | 0     | 0 | 0     | 0             | 16 |
| 3:55 PM                         | 0                      | 0    | 0     | 0 | 0                      | 0    | 0     | 0 | 1                     | 0    | 0     | 0 | 0                     | 0    | 0     | 0 | 0     | 1             | 13 |
| 4:00 PM                         | 1                      | 0    | 0     | 0 | 0                      | 0    | 0     | 0 | 0                     | 0    | 0     | 0 | 0                     | 0    | 0     | 0 | 0     | 1             | 11 |
| 4:05 PM                         | 0                      | 0    | 1     | 0 | 0                      | 1    | 0     | 0 | 0                     | 0    | 0     | 0 | 0                     | 0    | 0     | 0 | 0     | 2             | 12 |
| 4:10 PM                         | 0                      | 0    | 0     | 0 | 0                      | 0    | 0     | 0 | 0                     | 0    | 0     | 0 | 0                     | 0    | 1     | 0 | 0     | 1             | 10 |
| 4:15 PM                         | 0                      | 0    | 0     | 0 | 0                      | 1    | 0     | 0 | 0                     | 1    | 0     | 0 | 0                     | 0    | 0     | 0 | 0     | 2             | 11 |
| 4:20 PM                         | 0                      | 0    | 1     | 0 | 0                      | 0    | 0     | 0 | 0                     | 1    | 0     | 0 | 0                     | 0    | 0     | 0 | 0     | 2             | 13 |
| 4:25 PM                         | 0                      | 0    | 0     | 0 | 0                      | 0    | 0     | 0 | 0                     | 0    | 0     | 0 | 0                     | 0    | 0     | 0 | 0     | 0             | 12 |
| 4:30 PM                         | 0                      | 1    | 0     | 0 | 0                      | 0    | 0     | 0 | 0                     | 0    | 0     | 0 | 0                     | 0    | 0     | 0 | 0     | 1             | 13 |

**Attachment B**

| 5-Min Count Period Beginning At | Meadowood (Northbound) |      |       |   | Meadowood (Southbound) |      |       |   | Greenvale (Eastbound) |      |       |   | Greenvale (Westbound) |      |       |   | Total | Hourly Totals |
|---------------------------------|------------------------|------|-------|---|------------------------|------|-------|---|-----------------------|------|-------|---|-----------------------|------|-------|---|-------|---------------|
|                                 | Left                   | Thru | Right | U | Left                   | Thru | Right | U | Left                  | Thru | Right | U | Left                  | Thru | Right | U |       |               |
| 4:35 PM                         | 0                      | 0    | 0     | 0 | 0                      | 0    | 0     | 0 | 1                     | 0    | 0     | 0 | 0                     | 0    | 0     | 0 | 1     | 13            |
| 4:40 PM                         | 0                      | 0    | 0     | 0 | 0                      | 0    | 0     | 0 | 0                     | 0    | 0     | 0 | 0                     | 0    | 0     | 0 | 0     | 12            |
| 4:45 PM                         | 0                      | 0    | 0     | 0 | 0                      | 0    | 0     | 0 | 1                     | 0    | 0     | 0 | 0                     | 0    | 0     | 0 | 1     | 12            |
| 4:50 PM                         | 0                      | 0    | 0     | 0 | 0                      | 0    | 1     | 0 | 0                     | 0    | 0     | 0 | 0                     | 0    | 0     | 0 | 1     | 13            |
| 4:55 PM                         | 0                      | 0    | 0     | 0 | 0                      | 0    | 0     | 0 | 0                     | 0    | 0     | 0 | 0                     | 0    | 0     | 0 | 0     | 12            |
| 5:00 PM                         | 0                      | 0    | 0     | 0 | 0                      | 0    | 0     | 0 | 0                     | 0    | 1     | 0 | 0                     | 1    | 0     | 0 | 2     | 13            |
| 5:05 PM                         | 0                      | 1    | 0     | 0 | 0                      | 0    | 0     | 0 | 0                     | 0    | 0     | 0 | 0                     | 0    | 0     | 0 | 1     | 12            |
| 5:10 PM                         | 0                      | 0    | 0     | 0 | 0                      | 0    | 0     | 0 | 0                     | 0    | 0     | 0 | 0                     | 0    | 0     | 0 | 0     | 11            |
| 5:15 PM                         | 0                      | 0    | 0     | 0 | 0                      | 0    | 0     | 0 | 0                     | 0    | 0     | 0 | 0                     | 0    | 0     | 0 | 0     | 9             |
| 5:20 PM                         | 0                      | 1    | 0     | 0 | 0                      | 1    | 0     | 0 | 0                     | 0    | 0     | 0 | 0                     | 1    | 0     | 0 | 3     | 10            |
| 5:25 PM                         | 2                      | 0    | 0     | 0 | 0                      | 0    | 0     | 0 | 0                     | 0    | 0     | 0 | 0                     | 0    | 0     | 0 | 2     | 12            |
| 5:30 PM                         | 0                      | 0    | 0     | 0 | 0                      | 0    | 1     | 0 | 0                     | 0    | 0     | 0 | 0                     | 1    | 0     | 0 | 2     | 13            |
| 5:35 PM                         | 0                      | 0    | 0     | 0 | 0                      | 0    | 0     | 0 | 0                     | 1    | 0     | 0 | 0                     | 0    | 0     | 0 | 1     | 13            |
| 5:40 PM                         | 1                      | 0    | 0     | 0 | 0                      | 1    | 0     | 0 | 0                     | 0    | 1     | 0 | 0                     | 0    | 0     | 0 | 3     | 16            |
| 5:45 PM                         | 0                      | 0    | 0     | 0 | 0                      | 0    | 0     | 0 | 0                     | 0    | 1     | 0 | 0                     | 0    | 0     | 0 | 1     | 16            |
| 5:50 PM                         | 0                      | 1    | 0     | 0 | 0                      | 0    | 1     | 0 | 0                     | 0    | 0     | 0 | 0                     | 0    | 0     | 0 | 2     | 17            |
| 5:55 PM                         | 0                      | 1    | 0     | 0 | 0                      | 0    | 0     | 0 | 0                     | 0    | 0     | 0 | 0                     | 0    | 0     | 0 | 1     | 18            |
| 6:00 PM                         | 0                      | 0    | 0     | 0 | 0                      | 0    | 0     | 0 | 0                     | 0    | 0     | 0 | 0                     | 0    | 0     | 0 | 0     | 16            |
| 6:05 PM                         | 0                      | 1    | 0     | 0 | 0                      | 0    | 0     | 0 | 0                     | 1    | 0     | 0 | 0                     | 0    | 0     | 0 | 2     | 17            |
| 6:10 PM                         | 0                      | 0    | 0     | 0 | 0                      | 0    | 0     | 0 | 0                     | 0    | 0     | 0 | 0                     | 0    | 0     | 0 | 0     | 17            |
| 6:15 PM                         | 0                      | 0    | 0     | 0 | 0                      | 0    | 0     | 0 | 0                     | 0    | 0     | 0 | 0                     | 0    | 0     | 0 | 0     | 17            |
| 6:20 PM                         | 0                      | 1    | 0     | 0 | 0                      | 0    | 0     | 0 | 0                     | 0    | 0     | 0 | 0                     | 0    | 0     | 0 | 1     | 15            |
| 6:25 PM                         | 0                      | 0    | 0     | 0 | 0                      | 0    | 0     | 0 | 0                     | 0    | 0     | 0 | 0                     | 0    | 0     | 0 | 0     | 13            |
| 6:30 PM                         | 0                      | 0    | 0     | 0 | 0                      | 0    | 0     | 0 | 0                     | 0    | 0     | 0 | 0                     | 0    | 0     | 0 | 0     | 11            |
| 6:35 PM                         | 0                      | 0    | 0     | 0 | 0                      | 0    | 0     | 0 | 0                     | 0    | 0     | 0 | 0                     | 0    | 0     | 0 | 0     | 10            |
| 6:40 PM                         | 1                      | 0    | 0     | 0 | 0                      | 0    | 0     | 0 | 0                     | 0    | 0     | 0 | 0                     | 0    | 0     | 0 | 1     | 8             |
| 6:45 PM                         | 0                      | 0    | 0     | 0 | 0                      | 0    | 0     | 0 | 0                     | 0    | 0     | 0 | 0                     | 0    | 0     | 0 | 0     | 7             |
| 6:50 PM                         | 0                      | 0    | 0     | 0 | 0                      | 0    | 0     | 0 | 1                     | 0    | 0     | 0 | 0                     | 0    | 0     | 0 | 1     | 6             |
| 6:55 PM                         | 0                      | 0    | 0     | 0 | 0                      | 0    | 0     | 0 | 0                     | 0    | 0     | 0 | 0                     | 0    | 0     | 0 | 0     | 5             |
| 7:00 PM                         | 0                      | 0    | 0     | 0 | 0                      | 1    | 0     | 0 | 0                     | 0    | 0     | 0 | 0                     | 0    | 0     | 0 | 1     | 6             |
| 7:05 PM                         | 0                      | 0    | 1     | 0 | 0                      | 0    | 0     | 0 | 0                     | 0    | 0     | 0 | 0                     | 0    | 0     | 0 | 1     | 5             |
| 7:10 PM                         | 0                      | 0    | 0     | 0 | 0                      | 0    | 0     | 0 | 0                     | 1    | 0     | 0 | 0                     | 0    | 0     | 0 | 1     | 6             |
| 7:15 PM                         | 0                      | 0    | 0     | 0 | 0                      | 0    | 0     | 0 | 0                     | 0    | 0     | 0 | 0                     | 0    | 0     | 0 | 0     | 6             |
| 7:20 PM                         | 0                      | 0    | 0     | 0 | 0                      | 0    | 0     | 0 | 0                     | 0    | 0     | 0 | 0                     | 0    | 0     | 0 | 0     | 5             |
| 7:25 PM                         | 0                      | 0    | 0     | 0 | 0                      | 0    | 0     | 0 | 1                     | 1    | 0     | 0 | 0                     | 0    | 0     | 0 | 2     | 7             |
| 7:30 PM                         | 0                      | 0    | 0     | 0 | 0                      | 0    | 0     | 0 | 0                     | 0    | 0     | 0 | 0                     | 0    | 0     | 0 | 0     | 7             |
| 7:35 PM                         | 0                      | 0    | 0     | 0 | 0                      | 0    | 0     | 0 | 1                     | 0    | 1     | 0 | 0                     | 0    | 0     | 0 | 2     | 9             |
| 7:40 PM                         | 0                      | 0    | 0     | 0 | 0                      | 0    | 0     | 0 | 1                     | 0    | 0     | 0 | 0                     | 0    | 0     | 0 | 1     | 9             |
| 7:45 PM                         | 0                      | 0    | 0     | 0 | 0                      | 0    | 0     | 0 | 0                     | 0    | 0     | 0 | 0                     | 0    | 0     | 0 | 0     | 9             |
| 7:50 PM                         | 0                      | 0    | 0     | 0 | 0                      | 0    | 0     | 0 | 0                     | 0    | 0     | 0 | 0                     | 0    | 0     | 0 | 0     | 8             |
| 7:55 PM                         | 0                      | 0    | 0     | 0 | 0                      | 0    | 0     | 0 | 0                     | 0    | 0     | 0 | 1                     | 1    | 0     | 0 | 2     | 10            |
| 8:00 PM                         | 0                      | 0    | 0     | 0 | 0                      | 0    | 0     | 0 | 0                     | 0    | 0     | 0 | 0                     | 0    | 0     | 0 | 0     | 9             |
| 8:05 PM                         | 0                      | 0    | 0     | 0 | 0                      | 0    | 0     | 0 | 0                     | 0    | 0     | 0 | 0                     | 0    | 0     | 0 | 0     | 8             |
| 8:10 PM                         | 0                      | 0    | 0     | 0 | 0                      | 0    | 0     | 0 | 0                     | 0    | 0     | 0 | 0                     | 0    | 0     | 0 | 0     | 7             |
| 8:15 PM                         | 0                      | 0    | 0     | 0 | 0                      | 0    | 0     | 0 | 0                     | 0    | 0     | 0 | 0                     | 0    | 0     | 0 | 0     | 7             |
| 8:20 PM                         | 0                      | 0    | 0     | 0 | 0                      | 0    | 0     | 0 | 0                     | 0    | 0     | 0 | 0                     | 0    | 0     | 0 | 0     | 7             |
| 8:25 PM                         | 0                      | 0    | 0     | 0 | 0                      | 0    | 0     | 0 | 1                     | 0    | 0     | 0 | 0                     | 0    | 0     | 0 | 1     | 6             |
| 8:30 PM                         | 0                      | 0    | 0     | 0 | 0                      | 0    | 1     | 0 | 0                     | 0    | 0     | 0 | 0                     | 0    | 0     | 0 | 1     | 7             |
| 8:35 PM                         | 0                      | 0    | 0     | 0 | 0                      | 0    | 0     | 0 | 0                     | 0    | 0     | 0 | 0                     | 0    | 0     | 0 | 0     | 5             |
| 8:40 PM                         | 0                      | 0    | 0     | 0 | 0                      | 0    | 0     | 0 | 0                     | 0    | 0     | 0 | 0                     | 0    | 0     | 0 | 0     | 4             |
| 8:45 PM                         | 0                      | 0    | 0     | 0 | 0                      | 0    | 0     | 0 | 0                     | 0    | 0     | 0 | 0                     | 0    | 0     | 0 | 0     | 4             |
| 8:50 PM                         | 0                      | 0    | 0     | 0 | 0                      | 0    | 1     | 0 | 1                     | 0    | 0     | 0 | 0                     | 0    | 0     | 0 | 2     | 6             |
| 8:55 PM                         | 0                      | 0    | 0     | 0 | 0                      | 0    | 0     | 0 | 0                     | 0    | 0     | 0 | 0                     | 0    | 0     | 0 | 0     | 4             |
| 9:00 PM                         | 0                      | 0    | 0     | 0 | 0                      | 0    | 0     | 0 | 0                     | 0    | 0     | 0 | 0                     | 0    | 0     | 0 | 0     | 4             |
| 9:05 PM                         | 0                      | 0    | 0     | 0 | 0                      | 0    | 0     | 0 | 0                     | 0    | 0     | 0 | 0                     | 0    | 0     | 0 | 0     | 4             |
| 9:10 PM                         | 0                      | 0    | 0     | 0 | 0                      | 0    | 0     | 0 | 0                     | 0    | 0     | 0 | 0                     | 0    | 0     | 0 | 0     | 4             |
| 9:15 PM                         | 0                      | 0    | 0     | 0 | 0                      | 0    | 0     | 0 | 0                     | 0    | 1     | 0 | 0                     | 0    | 0     | 0 | 1     | 5             |
| 9:20 PM                         | 0                      | 0    | 0     | 0 | 0                      | 0    | 0     | 0 | 0                     | 0    | 0     | 0 | 0                     | 0    | 0     | 0 | 0     | 5             |
| 9:25 PM                         | 0                      | 0    | 0     | 0 | 0                      | 0    | 0     | 0 | 0                     | 0    | 0     | 0 | 0                     | 0    | 0     | 0 | 0     | 4             |
| 9:30 PM                         | 0                      | 1    | 0     | 0 | 0                      | 0    | 0     | 0 | 0                     | 0    | 0     | 0 | 0                     | 0    | 0     | 0 | 1     | 4             |
| 9:35 PM                         | 0                      | 1    | 0     | 0 | 0                      | 0    | 0     | 0 | 1                     | 0    | 0     | 0 | 0                     | 0    | 0     | 0 | 2     | 6             |
| 9:40 PM                         | 0                      | 0    | 0     | 0 | 0                      | 0    | 0     | 0 | 0                     | 0    | 0     | 0 | 0                     | 0    | 0     | 0 | 0     | 6             |
| 9:45 PM                         | 0                      | 0    | 0     | 0 | 0                      | 0    | 0     | 0 | 0                     | 0    | 0     | 0 | 0                     | 0    | 0     | 0 | 0     | 6             |
| 9:50 PM                         | 0                      | 0    | 0     | 0 | 0                      | 0    | 0     | 0 | 0                     | 0    | 0     | 0 | 0                     | 0    | 0     | 0 | 0     | 4             |
| 9:55 PM                         | 0                      | 0    | 0     | 0 | 0                      | 0    | 0     | 0 | 0                     | 0    | 0     | 0 | 0                     | 0    | 0     | 0 | 0     | 4             |
| Peak 15-Min Flowrates           | Northbound             |      |       |   | Southbound             |      |       |   | Eastbound             |      |       |   | Westbound             |      |       |   | Total |               |
|                                 | Left                   | Thru | Right | U | Left                   | Thru | Right | U | Left                  | Thru | Right | U | Left                  | Thru | Right | U |       |               |
| All Vehicles                    | 4                      | 0    | 0     | 0 | 0                      | 0    | 20    | 0 | 4                     | 4    | 0     | 0 | 0                     | 0    | 0     | 0 | 32    |               |
| Heavy Trucks                    | 0                      | 0    | 0     | 0 | 0                      | 0    | 0     | 0 | 0                     | 0    | 0     | 0 | 0                     | 0    | 0     | 0 | 0     |               |
| Buses                           |                        |      |       |   |                        |      |       |   |                       |      |       |   |                       |      |       |   |       |               |
| Pedestrians                     |                        | 0    |       |   |                        | 0    |       |   |                       | 0    |       |   |                       | 0    |       |   | 0     |               |
| Bicycles                        | 0                      | 0    | 0     |   | 0                      | 0    | 0     |   | 0                     | 0    | 0     |   | 0                     | 0    | 0     |   | 0     |               |
| Scoters                         |                        |      |       |   |                        |      |       |   |                       |      |       |   |                       |      |       |   |       |               |
| <i>Comments:</i>                |                        |      |       |   |                        |      |       |   |                       |      |       |   |                       |      |       |   |       |               |

Type of peak hour being reported: Intersection Peak

Method for determining peak hour: Total Entering Volume

LOCATION: Woodsong -- Castletree  
 CITY/STATE: Las Flores, CA

QC JOB #: 16966452  
 DATE: Wed, Apr 16 2025

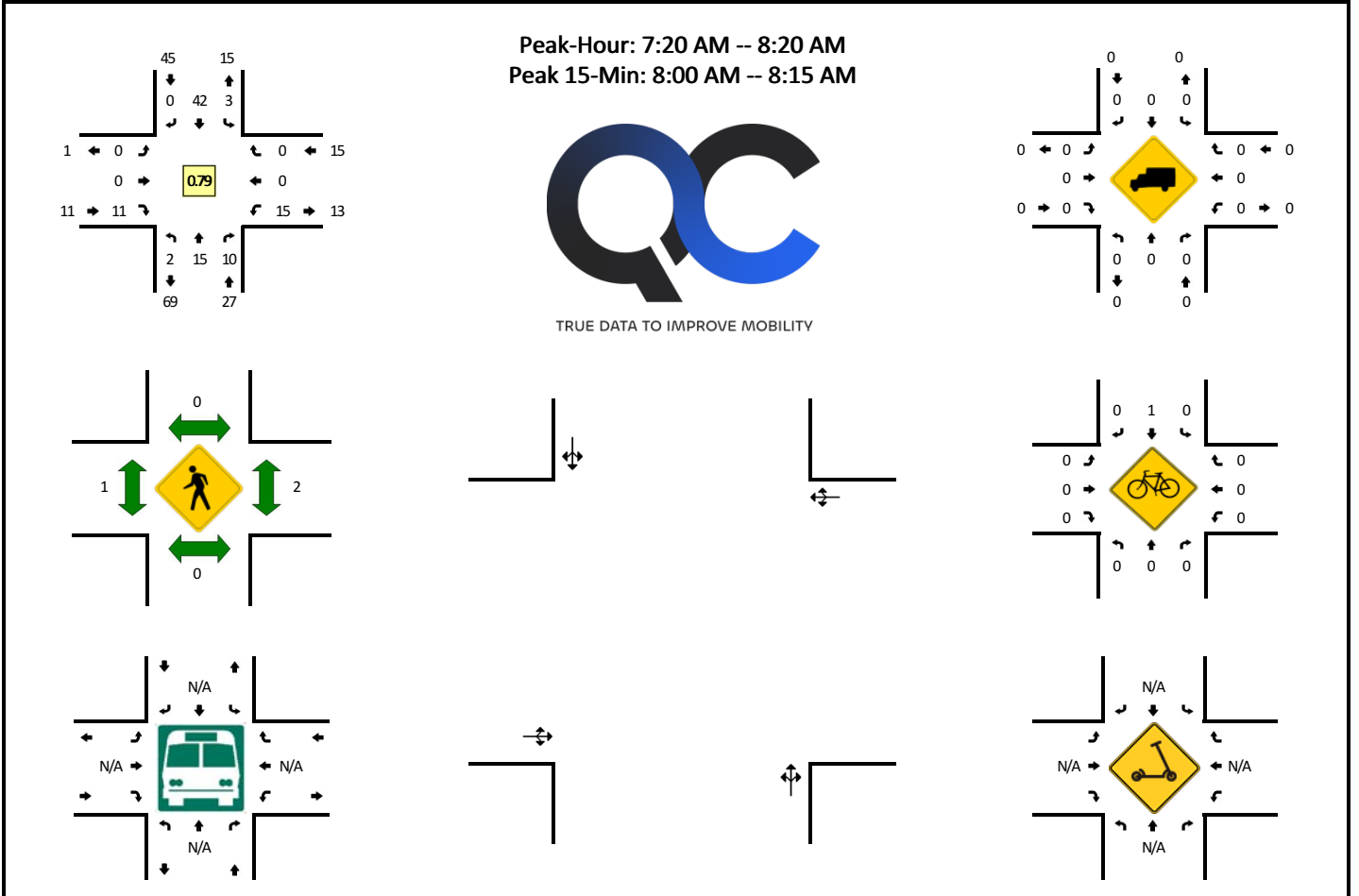

| 5-Min Count Period Beginning At | Woodsong (Northbound) |      |       |   | Woodsong (Southbound) |      |       |   | Castletree (Eastbound) |      |       |   | Castletree (Westbound) |      |       |   | Total | Hourly Totals |
|---------------------------------|-----------------------|------|-------|---|-----------------------|------|-------|---|------------------------|------|-------|---|------------------------|------|-------|---|-------|---------------|
|                                 | Left                  | Thru | Right | U | Left                  | Thru | Right | U | Left                   | Thru | Right | U | Left                   | Thru | Right | U |       |               |
| 6:00 AM                         | 0                     | 0    | 0     | 0 | 0                     | 1    | 0     | 0 | 0                      | 0    | 0     | 1 | 0                      | 0    | 0     | 0 | 2     |               |
| 6:05 AM                         | 0                     | 0    | 0     | 0 | 0                     | 2    | 0     | 0 | 0                      | 0    | 0     | 0 | 0                      | 0    | 0     | 0 | 2     |               |
| 6:10 AM                         | 0                     | 0    | 0     | 0 | 0                     | 0    | 0     | 0 | 0                      | 0    | 0     | 1 | 0                      | 0    | 0     | 0 | 1     |               |
| 6:15 AM                         | 0                     | 0    | 1     | 0 | 0                     | 0    | 0     | 0 | 0                      | 0    | 0     | 0 | 0                      | 0    | 0     | 0 | 1     |               |
| 6:20 AM                         | 0                     | 1    | 0     | 0 | 0                     | 2    | 0     | 0 | 0                      | 0    | 0     | 2 | 0                      | 1    | 0     | 0 | 6     |               |
| 6:25 AM                         | 0                     | 1    | 1     | 0 | 0                     | 1    | 0     | 0 | 0                      | 0    | 0     | 1 | 0                      | 0    | 0     | 0 | 4     |               |
| 6:30 AM                         | 0                     | 0    | 0     | 0 | 0                     | 3    | 0     | 0 | 0                      | 0    | 0     | 0 | 0                      | 1    | 0     | 1 | 5     |               |
| 6:35 AM                         | 0                     | 0    | 1     | 0 | 0                     | 0    | 0     | 0 | 0                      | 0    | 0     | 1 | 0                      | 0    | 0     | 0 | 2     |               |
| 6:40 AM                         | 0                     | 0    | 1     | 0 | 0                     | 1    | 0     | 0 | 0                      | 0    | 0     | 0 | 0                      | 0    | 0     | 0 | 2     |               |
| 6:45 AM                         | 0                     | 0    | 0     | 0 | 0                     | 0    | 0     | 0 | 0                      | 0    | 0     | 1 | 0                      | 1    | 0     | 0 | 2     |               |
| 6:50 AM                         | 0                     | 0    | 0     | 0 | 0                     | 2    | 0     | 0 | 0                      | 0    | 0     | 2 | 0                      | 0    | 0     | 0 | 6     |               |
| 6:55 AM                         | 0                     | 1    | 0     | 0 | 0                     | 1    | 0     | 0 | 0                      | 0    | 0     | 0 | 0                      | 1    | 0     | 0 | 3     | 36            |
| 7:00 AM                         | 0                     | 2    | 0     | 0 | 0                     | 0    | 0     | 0 | 0                      | 0    | 0     | 0 | 0                      | 0    | 0     | 0 | 2     | 36            |
| 7:05 AM                         | 1                     | 0    | 0     | 0 | 0                     | 1    | 0     | 0 | 0                      | 0    | 0     | 1 | 0                      | 0    | 0     | 0 | 4     | 38            |
| 7:10 AM                         | 0                     | 0    | 0     | 0 | 0                     | 6    | 0     | 0 | 0                      | 0    | 0     | 0 | 0                      | 0    | 0     | 0 | 6     | 43            |
| 7:15 AM                         | 1                     | 2    | 0     | 0 | 0                     | 0    | 0     | 0 | 0                      | 0    | 0     | 0 | 0                      | 1    | 0     | 0 | 4     | 46            |
| 7:20 AM                         | 0                     | 1    | 1     | 0 | 1                     | 4    | 0     | 0 | 0                      | 0    | 0     | 1 | 0                      | 1    | 0     | 0 | 9     | 49            |
| 7:25 AM                         | 0                     | 0    | 1     | 0 | 1                     | 4    | 0     | 0 | 0                      | 0    | 0     | 0 | 0                      | 2    | 0     | 0 | 8     | 53            |
| 7:30 AM                         | 0                     | 0    | 1     | 0 | 0                     | 1    | 0     | 0 | 0                      | 0    | 0     | 0 | 0                      | 0    | 0     | 0 | 2     | 50            |
| 7:35 AM                         | 1                     | 1    | 0     | 0 | 0                     | 3    | 0     | 0 | 0                      | 0    | 0     | 2 | 0                      | 1    | 0     | 0 | 8     | 56            |
| 7:40 AM                         | 0                     | 0    | 1     | 0 | 0                     | 3    | 0     | 0 | 0                      | 0    | 0     | 0 | 0                      | 4    | 0     | 0 | 8     | 62            |
| 7:45 AM                         | 0                     | 2    | 2     | 0 | 0                     | 4    | 0     | 0 | 0                      | 0    | 0     | 0 | 0                      | 1    | 0     | 0 | 9     | 69            |
| 7:50 AM                         | 0                     | 0    | 1     | 1 | 0                     | 4    | 0     | 0 | 0                      | 0    | 0     | 1 | 0                      | 2    | 0     | 0 | 9     | 72            |
| 7:55 AM                         | 0                     | 0    | 0     | 0 | 1                     | 3    | 0     | 0 | 0                      | 0    | 0     | 1 | 0                      | 3    | 0     | 0 | 8     | 77            |
| 8:00 AM                         | 0                     | 2    | 1     | 0 | 0                     | 8    | 0     | 0 | 0                      | 0    | 0     | 2 | 0                      | 0    | 0     | 0 | 13    | 88            |
| 8:05 AM                         | 0                     | 2    | 1     | 0 | 0                     | 3    | 0     | 0 | 0                      | 0    | 0     | 2 | 0                      | 1    | 0     | 0 | 9     | 93            |
| 8:10 AM                         | 0                     | 3    | 1     | 0 | 0                     | 4    | 0     | 0 | 0                      | 0    | 0     | 1 | 0                      | 0    | 0     | 0 | 9     | 96            |
| 8:15 AM                         | 0                     | 4    | 0     | 0 | 0                     | 1    | 0     | 0 | 0                      | 0    | 0     | 1 | 0                      | 0    | 0     | 0 | 6     | 98            |
| 8:20 AM                         | 0                     | 3    | 1     | 0 | 0                     | 2    | 0     | 0 | 0                      | 0    | 0     | 0 | 0                      | 0    | 0     | 0 | 6     | 95            |
| 8:25 AM                         | 1                     | 0    | 0     | 0 | 0                     | 0    | 0     | 0 | 0                      | 0    | 0     | 0 | 0                      | 1    | 0     | 0 | 2     | 89            |
| 8:30 AM                         | 3                     | 0    | 0     | 0 | 0                     | 2    | 0     | 0 | 0                      | 0    | 0     | 0 | 0                      | 3    | 0     | 0 | 8     | 95            |
| 8:35 AM                         | 1                     | 0    | 1     | 0 | 0                     | 5    | 0     | 0 | 1                      | 1    | 0     | 0 | 0                      | 1    | 0     | 0 | 9     | 96            |
| 8:40 AM                         | 0                     | 0    | 1     | 0 | 0                     | 2    | 0     | 0 | 0                      | 0    | 0     | 0 | 0                      | 1    | 0     | 0 | 4     | 92            |
| 8:45 AM                         | 1                     | 0    | 0     | 0 | 0                     | 2    | 0     | 0 | 0                      | 0    | 0     | 0 | 0                      | 0    | 0     | 0 | 3     | 86            |
| 8:50 AM                         | 0                     | 3    | 0     | 0 | 0                     | 1    | 0     | 0 | 0                      | 0    | 0     | 1 | 0                      | 1    | 0     | 0 | 6     | 83            |
| 8:55 AM                         | 0                     | 3    | 0     | 0 | 0                     | 0    | 0     | 0 | 0                      | 0    | 0     | 2 | 0                      | 0    | 0     | 0 | 5     | 80            |
| 9:00 AM                         | 0                     | 3    | 0     | 0 | 0                     | 1    | 0     | 0 | 0                      | 0    | 0     | 0 | 0                      | 1    | 0     | 0 | 5     | 72            |
| 9:05 AM                         | 0                     | 1    | 0     | 0 | 0                     | 1    | 0     | 0 | 0                      | 0    | 0     | 0 | 0                      | 0    | 0     | 0 | 2     | 65            |

**Attachment B**

| 5-Min Count Period Beginning At | Woodsong (Northbound) |      |       |   | Woodsong (Southbound) |      |       |   | Castletree (Eastbound) |      |       |   | Castletree (Westbound) |      |       |   | Total | Hourly Totals |    |
|---------------------------------|-----------------------|------|-------|---|-----------------------|------|-------|---|------------------------|------|-------|---|------------------------|------|-------|---|-------|---------------|----|
|                                 | Left                  | Thru | Right | U | Left                  | Thru | Right | U | Left                   | Thru | Right | U | Left                   | Thru | Right | U |       |               |    |
| 9:10 AM                         | 0                     | 0    | 0     | 0 | 0                     | 3    | 0     | 0 | 0                      | 0    | 0     | 2 | 0                      | 0    | 0     | 0 | 0     | 5             | 61 |
| 9:15 AM                         | 0                     | 0    | 1     | 0 | 0                     | 0    | 0     | 0 | 0                      | 0    | 0     | 0 | 0                      | 0    | 0     | 0 | 0     | 1             | 56 |
| 9:20 AM                         | 1                     | 0    | 0     | 0 | 0                     | 1    | 0     | 0 | 0                      | 0    | 0     | 0 | 0                      | 0    | 0     | 0 | 0     | 2             | 52 |
| 9:25 AM                         | 0                     | 1    | 0     | 0 | 0                     | 3    | 0     | 0 | 0                      | 0    | 0     | 0 | 0                      | 0    | 0     | 0 | 0     | 4             | 54 |
| 9:30 AM                         | 0                     | 1    | 0     | 0 | 0                     | 3    | 0     | 0 | 0                      | 0    | 0     | 1 | 0                      | 1    | 0     | 0 | 0     | 6             | 52 |
| 9:35 AM                         | 1                     | 1    | 0     | 0 | 0                     | 0    | 0     | 0 | 0                      | 0    | 0     | 0 | 0                      | 1    | 0     | 0 | 0     | 3             | 46 |
| 9:40 AM                         | 1                     | 0    | 0     | 0 | 0                     | 0    | 0     | 0 | 0                      | 0    | 0     | 1 | 0                      | 1    | 0     | 0 | 0     | 3             | 45 |
| 9:45 AM                         | 0                     | 2    | 0     | 0 | 0                     | 1    | 0     | 0 | 0                      | 0    | 0     | 0 | 0                      | 1    | 0     | 0 | 0     | 4             | 46 |
| 9:50 AM                         | 1                     | 2    | 0     | 0 | 0                     | 1    | 0     | 0 | 0                      | 0    | 0     | 0 | 0                      | 0    | 0     | 0 | 0     | 4             | 44 |
| 9:55 AM                         | 0                     | 1    | 0     | 0 | 0                     | 0    | 0     | 0 | 0                      | 0    | 0     | 0 | 0                      | 0    | 0     | 0 | 0     | 1             | 40 |
| 10:00 AM                        | 0                     | 1    | 0     | 0 | 0                     | 2    | 0     | 0 | 0                      | 0    | 0     | 1 | 0                      | 0    | 0     | 0 | 0     | 4             | 39 |
| 10:05 AM                        | 0                     | 0    | 1     | 0 | 0                     | 1    | 0     | 0 | 0                      | 0    | 0     | 0 | 0                      | 0    | 0     | 0 | 0     | 2             | 39 |
| 10:10 AM                        | 1                     | 1    | 0     | 0 | 0                     | 2    | 0     | 0 | 0                      | 0    | 0     | 0 | 0                      | 1    | 0     | 0 | 0     | 5             | 39 |
| 10:15 AM                        | 1                     | 2    | 0     | 0 | 0                     | 0    | 0     | 0 | 0                      | 1    | 0     | 0 | 0                      | 0    | 0     | 0 | 0     | 4             | 42 |
| 10:20 AM                        | 2                     | 0    | 0     | 0 | 0                     | 1    | 0     | 0 | 0                      | 0    | 1     | 0 | 0                      | 1    | 0     | 0 | 0     | 5             | 45 |
| 10:25 AM                        | 1                     | 0    | 0     | 0 | 1                     | 1    | 0     | 0 | 0                      | 0    | 0     | 0 | 0                      | 0    | 0     | 0 | 0     | 3             | 44 |
| 10:30 AM                        | 0                     | 0    | 0     | 0 | 0                     | 1    | 0     | 0 | 0                      | 0    | 0     | 0 | 0                      | 0    | 0     | 0 | 0     | 1             | 39 |
| 10:35 AM                        | 0                     | 1    | 0     | 0 | 0                     | 2    | 0     | 0 | 0                      | 0    | 0     | 0 | 0                      | 0    | 0     | 0 | 0     | 3             | 39 |
| 10:40 AM                        | 0                     | 0    | 0     | 0 | 0                     | 3    | 0     | 0 | 0                      | 0    | 0     | 0 | 0                      | 1    | 0     | 0 | 0     | 4             | 40 |
| 10:45 AM                        | 0                     | 0    | 0     | 0 | 0                     | 2    | 0     | 0 | 0                      | 0    | 0     | 0 | 0                      | 0    | 0     | 0 | 0     | 2             | 38 |
| 10:50 AM                        | 0                     | 0    | 1     | 0 | 0                     | 0    | 0     | 0 | 0                      | 0    | 0     | 1 | 0                      | 0    | 0     | 0 | 0     | 2             | 36 |
| 10:55 AM                        | 0                     | 0    | 0     | 0 | 0                     | 0    | 0     | 0 | 0                      | 0    | 0     | 0 | 0                      | 0    | 0     | 0 | 0     | 0             | 35 |
| 11:00 AM                        | 0                     | 1    | 0     | 0 | 0                     | 1    | 0     | 0 | 0                      | 0    | 0     | 0 | 0                      | 0    | 0     | 0 | 0     | 2             | 33 |
| 11:05 AM                        | 0                     | 3    | 1     | 0 | 0                     | 3    | 0     | 0 | 0                      | 0    | 0     | 0 | 0                      | 0    | 0     | 0 | 0     | 7             | 38 |
| 11:10 AM                        | 1                     | 1    | 0     | 0 | 0                     | 0    | 0     | 0 | 0                      | 0    | 0     | 0 | 0                      | 0    | 0     | 0 | 0     | 2             | 35 |
| 11:15 AM                        | 1                     | 1    | 1     | 0 | 0                     | 2    | 0     | 0 | 0                      | 0    | 0     | 1 | 0                      | 0    | 0     | 0 | 0     | 6             | 37 |
| 11:20 AM                        | 0                     | 2    | 0     | 0 | 1                     | 1    | 0     | 0 | 0                      | 0    | 0     | 0 | 0                      | 0    | 0     | 1 | 0     | 5             | 37 |
| 11:25 AM                        | 0                     | 3    | 0     | 0 | 0                     | 4    | 0     | 0 | 0                      | 0    | 0     | 1 | 0                      | 1    | 0     | 0 | 0     | 9             | 43 |
| 11:30 AM                        | 1                     | 1    | 0     | 0 | 0                     | 2    | 0     | 0 | 0                      | 0    | 0     | 0 | 0                      | 0    | 0     | 0 | 0     | 4             | 46 |
| 11:35 AM                        | 0                     | 0    | 0     | 0 | 0                     | 3    | 0     | 0 | 0                      | 0    | 0     | 0 | 0                      | 0    | 0     | 0 | 0     | 3             | 46 |
| 11:40 AM                        | 0                     | 0    | 2     | 0 | 0                     | 0    | 0     | 0 | 0                      | 0    | 0     | 0 | 0                      | 1    | 0     | 0 | 0     | 3             | 45 |
| 11:45 AM                        | 0                     | 0    | 0     | 0 | 0                     | 3    | 0     | 0 | 0                      | 0    | 0     | 0 | 0                      | 1    | 0     | 0 | 0     | 4             | 47 |
| 11:50 AM                        | 1                     | 1    | 0     | 0 | 0                     | 1    | 0     | 0 | 0                      | 0    | 0     | 1 | 0                      | 0    | 0     | 0 | 0     | 4             | 49 |
| 11:55 AM                        | 1                     | 4    | 0     | 0 | 0                     | 1    | 0     | 0 | 0                      | 0    | 0     | 0 | 0                      | 0    | 0     | 0 | 0     | 6             | 55 |
| 12:00 PM                        | 0                     | 0    | 0     | 0 | 0                     | 2    | 0     | 0 | 0                      | 0    | 0     | 0 | 0                      | 0    | 0     | 0 | 0     | 2             | 55 |
| 12:05 PM                        | 1                     | 0    | 0     | 1 | 0                     | 1    | 0     | 0 | 0                      | 0    | 0     | 0 | 0                      | 0    | 0     | 0 | 0     | 3             | 51 |
| 12:10 PM                        | 0                     | 3    | 1     | 0 | 0                     | 1    | 0     | 0 | 0                      | 0    | 0     | 0 | 0                      | 0    | 0     | 0 | 0     | 5             | 54 |
| 12:15 PM                        | 1                     | 1    | 0     | 0 | 0                     | 0    | 0     | 0 | 0                      | 1    | 0     | 0 | 0                      | 0    | 0     | 0 | 0     | 3             | 51 |
| 12:20 PM                        | 0                     | 1    | 0     | 0 | 0                     | 3    | 0     | 0 | 0                      | 0    | 0     | 0 | 0                      | 0    | 0     | 0 | 0     | 4             | 50 |
| 12:25 PM                        | 0                     | 1    | 0     | 0 | 0                     | 0    | 0     | 0 | 0                      | 0    | 0     | 1 | 0                      | 0    | 0     | 0 | 0     | 2             | 43 |
| 12:30 PM                        | 0                     | 0    | 1     | 0 | 0                     | 1    | 0     | 0 | 0                      | 0    | 0     | 0 | 0                      | 1    | 0     | 0 | 0     | 3             | 42 |
| 12:35 PM                        | 0                     | 1    | 0     | 0 | 0                     | 1    | 0     | 0 | 0                      | 0    | 0     | 0 | 0                      | 0    | 0     | 0 | 0     | 2             | 41 |
| 12:40 PM                        | 0                     | 3    | 0     | 0 | 0                     | 1    | 0     | 0 | 0                      | 0    | 0     | 0 | 0                      | 2    | 0     | 0 | 0     | 6             | 44 |
| 12:45 PM                        | 0                     | 1    | 1     | 0 | 0                     | 0    | 0     | 0 | 0                      | 0    | 0     | 0 | 0                      | 1    | 0     | 0 | 0     | 3             | 43 |
| 12:50 PM                        | 0                     | 2    | 0     | 0 | 0                     | 1    | 0     | 0 | 0                      | 0    | 0     | 0 | 0                      | 1    | 0     | 0 | 0     | 4             | 43 |
| 12:55 PM                        | 0                     | 1    | 0     | 0 | 0                     | 2    | 0     | 0 | 0                      | 0    | 0     | 0 | 0                      | 0    | 0     | 0 | 0     | 3             | 40 |
| 1:00 PM                         | 1                     | 1    | 0     | 0 | 0                     | 3    | 0     | 0 | 0                      | 0    | 0     | 0 | 0                      | 0    | 0     | 0 | 0     | 5             | 43 |
| 1:05 PM                         | 0                     | 4    | 0     | 0 | 0                     | 2    | 0     | 0 | 0                      | 0    | 0     | 1 | 0                      | 0    | 0     | 0 | 0     | 7             | 47 |
| 1:10 PM                         | 0                     | 2    | 0     | 0 | 0                     | 0    | 0     | 0 | 0                      | 0    | 0     | 0 | 0                      | 0    | 0     | 0 | 0     | 2             | 44 |
| 1:15 PM                         | 0                     | 2    | 0     | 0 | 0                     | 6    | 0     | 0 | 0                      | 0    | 0     | 1 | 0                      | 2    | 0     | 1 | 0     | 12            | 53 |
| 1:20 PM                         | 0                     | 2    | 0     | 0 | 0                     | 2    | 0     | 0 | 0                      | 0    | 0     | 1 | 0                      | 1    | 0     | 0 | 0     | 6             | 55 |
| 1:25 PM                         | 1                     | 2    | 4     | 0 | 0                     | 2    | 0     | 0 | 0                      | 0    | 0     | 0 | 0                      | 0    | 0     | 0 | 0     | 9             | 62 |
| 1:30 PM                         | 1                     | 4    | 0     | 0 | 0                     | 1    | 0     | 0 | 0                      | 0    | 0     | 1 | 0                      | 1    | 0     | 0 | 0     | 8             | 67 |
| 1:35 PM                         | 0                     | 2    | 0     | 0 | 0                     | 3    | 0     | 0 | 0                      | 0    | 0     | 0 | 0                      | 0    | 0     | 0 | 0     | 5             | 70 |
| 1:40 PM                         | 0                     | 2    | 0     | 0 | 0                     | 3    | 0     | 0 | 0                      | 0    | 0     | 1 | 0                      | 0    | 0     | 0 | 0     | 6             | 70 |
| 1:45 PM                         | 0                     | 5    | 0     | 0 | 0                     | 2    | 0     | 0 | 0                      | 0    | 0     | 0 | 0                      | 0    | 0     | 0 | 0     | 7             | 74 |
| 1:50 PM                         | 0                     | 1    | 1     | 0 | 0                     | 5    | 0     | 0 | 0                      | 0    | 0     | 1 | 0                      | 2    | 0     | 0 | 0     | 10            | 80 |
| 1:55 PM                         | 0                     | 4    | 0     | 0 | 0                     | 1    | 0     | 0 | 0                      | 0    | 0     | 2 | 0                      | 0    | 0     | 0 | 0     | 7             | 84 |
| 2:00 PM                         | 0                     | 1    | 0     | 0 | 0                     | 1    | 0     | 0 | 0                      | 0    | 0     | 0 | 0                      | 1    | 0     | 1 | 0     | 4             | 83 |
| 2:05 PM                         | 0                     | 1    | 0     | 0 | 0                     | 1    | 0     | 0 | 0                      | 0    | 0     | 2 | 0                      | 0    | 0     | 1 | 0     | 5             | 81 |
| 2:10 PM                         | 0                     | 2    | 2     | 0 | 0                     | 3    | 1     | 0 | 0                      | 0    | 0     | 1 | 0                      | 1    | 0     | 0 | 0     | 10            | 89 |
| 2:15 PM                         | 1                     | 3    | 0     | 0 | 0                     | 0    | 0     | 0 | 0                      | 0    | 0     | 1 | 0                      | 0    | 0     | 0 | 0     | 5             | 82 |
| 2:20 PM                         | 0                     | 1    | 1     | 0 | 0                     | 0    | 0     | 0 | 0                      | 0    | 0     | 0 | 0                      | 3    | 0     | 0 | 0     | 5             | 81 |
| 2:25 PM                         | 1                     | 5    | 0     | 0 | 0                     | 1    | 0     | 0 | 0                      | 0    | 0     | 0 | 0                      | 0    | 0     | 0 | 0     | 7             | 79 |
| 2:30 PM                         | 1                     | 0    | 0     | 0 | 0                     | 0    | 0     | 0 | 0                      | 0    | 0     | 2 | 0                      | 0    | 0     | 0 | 0     | 3             | 74 |
| 2:35 PM                         | 0                     | 1    | 0     | 0 | 0                     | 0    | 0     | 0 | 0                      | 0    | 0     | 0 | 0                      | 2    | 0     | 0 | 0     | 3             | 72 |
| 2:40 PM                         | 1                     | 1    | 0     | 0 | 0                     | 1    | 0     | 0 | 0                      | 0    | 0     | 1 | 0                      | 1    | 0     | 0 | 0     | 5             | 71 |
| 2:45 PM                         | 1                     | 1    | 0     | 0 | 0                     | 5    | 0     | 0 | 0                      | 0    | 0     | 1 | 0                      | 1    | 0     | 0 | 0     | 9             | 73 |
| 2:50 PM                         | 0                     | 2    | 0     | 0 | 0                     | 0    | 0     | 0 | 0                      | 0    | 1     | 0 | 0                      | 2    | 0     | 0 | 0     | 5             | 68 |
| 2:55 PM                         | 1                     | 1    | 1     | 0 | 0                     | 2    | 0     | 0 | 0                      | 0    | 0     | 0 | 0                      | 0    | 0     | 0 | 0     | 5             | 66 |
| 3:00 PM                         | 2                     | 1    | 1     | 0 | 0                     | 0    | 0     | 0 | 0                      | 0    | 1     | 1 | 0                      | 0    | 1     | 0 | 0     | 7             | 69 |
| 3:05 PM                         | 0                     | 1    | 1     | 0 | 0                     | 1    | 0     | 0 | 0                      | 1    | 0     | 0 | 0                      | 0    | 0     | 0 | 0     | 4             | 68 |
| 3:10 PM                         | 0                     | 2    | 1     | 1 | 0                     | 6    | 0     | 0 | 0                      | 0    | 0     | 0 | 0                      | 0    | 0     | 0 | 0     | 10            | 68 |
| 3:15 PM                         | 0                     | 1    | 1     | 0 | 0                     | 2    | 0     | 0 | 0                      | 0    | 0     | 0 | 0                      | 0    | 0     | 0 | 0     | 4             | 67 |
| 3:20 PM                         | 0                     | 1    | 2     | 0 | 0                     | 4    | 0     | 0 | 0                      | 0    | 0     | 1 | 0                      | 1    | 0     | 0 | 0     | 9             | 71 |
| 3:25 PM                         | 2                     | 1    | 2     | 0 | 0                     | 2    | 0     | 0 | 0                      | 0    | 0     | 1 | 0                      | 0    | 1     | 0 | 0     | 9             | 73 |
| 3:30 PM                         | 1                     | 4    | 0     | 0 | 0                     | 2    | 0     | 0 | 0                      | 0    | 0     | 1 | 0                      | 0    | 0     | 0 | 0     | 8             | 78 |
| 3:35 PM                         | 1                     | 3    | 1     | 0 | 0                     | 0    | 0     | 0 | 0                      | 0    | 0     | 0 | 0                      | 1    | 0     | 0 | 0     | 6             | 81 |
| 3:40 PM                         | 3                     | 4    | 0     | 0 | 0                     | 2    | 0     | 0 | 0                      | 0    | 0     | 0 | 0                      | 0    | 0     | 0 | 0     | 9             | 85 |
| 3:45 PM                         | 0                     | 1    | 2     | 0 | 0                     | 3    | 0     | 0 | 0                      | 0    | 0     | 0 | 0                      | 1    | 0     | 0 | 0     | 7             | 83 |
| 3:50 PM                         | 0                     | 1    | 0     | 0 | 0                     | 0    | 0     | 0 | 0                      | 0    | 0     | 0 | 0                      | 0    | 0     | 0 | 0     | 1             | 79 |
| 3:55 PM                         | 0                     | 2    | 0     | 1 | 1                     | 2    | 0     | 0 | 0                      | 0    | 0     | 1 | 0                      | 1    | 0     | 0 | 0     | 8             | 82 |
| 4:00 PM                         | 2                     | 3    | 1     | 0 | 0                     | 2    | 0     | 0 | 0                      | 0    | 0     | 2 | 0                      | 1    | 0     | 0 | 0     | 11            | 86 |
| 4:05 PM                         | 1                     | 2    | 0     | 0 | 0                     | 1    | 0     | 0 | 0                      | 0    | 1     | 0 | 0                      | 1    | 0     | 0 | 0     | 6             | 88 |
| 4:10 PM                         | 2                     | 1    | 1     | 0 | 0                     | 0    | 0     | 0 | 0                      | 0    | 0     | 1 | 0                      | 0    | 0     | 0 | 0     | 5             | 83 |
| 4:15 PM                         | 1                     | 4    | 0     | 0 | 0                     | 2    | 0     | 0 | 0                      | 0    | 1     | 0 | 0                      | 0    | 0     | 0 | 0     | 8             | 87 |
| 4:20 PM                         | 0                     | 2    | 1     | 0 | 0                     | 0    | 0     | 0 | 0                      | 0    | 0     | 2 | 0                      | 0    | 0     | 1 | 0     | 6             | 84 |
| 4:25 PM                         | 1                     | 2    | 3     | 0 | 0                     | 2    | 0     | 0 | 0                      | 0    | 0     | 0 | 0                      | 1    | 0     | 0 | 0     | 9             | 84 |
| 4:30 PM                         | 2                     | 3    | 0     | 0 | 0                     | 0    | 0     | 0 | 0                      | 0    | 0     | 0 | 0                      | 1    | 0     | 0 | 0     | 6             | 82 |

**Attachment B**

| 5-Min Count Period Beginning At | Woodsong (Northbound) |      |       |   | Woodsong (Southbound) |      |       |   | Castletree (Eastbound) |      |       |    | Castletree (Westbound) |      |       |   | Total | Hourly Totals |
|---------------------------------|-----------------------|------|-------|---|-----------------------|------|-------|---|------------------------|------|-------|----|------------------------|------|-------|---|-------|---------------|
|                                 | Left                  | Thru | Right | U | Left                  | Thru | Right | U | Left                   | Thru | Right | U  | Left                   | Thru | Right | U |       |               |
| 4:35 PM                         | 0                     | 2    | 0     | 0 | 0                     | 1    | 0     | 0 | 0                      | 0    | 1     | 0  | 0                      | 0    | 0     | 0 | 4     | 80            |
| 4:40 PM                         | 0                     | 5    | 1     | 0 | 0                     | 4    | 0     | 0 | 0                      | 0    | 0     | 0  | 2                      | 0    | 0     | 0 | 12    | 83            |
| 4:45 PM                         | 0                     | 0    | 2     | 0 | 0                     | 1    | 0     | 0 | 0                      | 0    | 0     | 0  | 0                      | 0    | 0     | 0 | 3     | 79            |
| 4:50 PM                         | 0                     | 2    | 1     | 0 | 0                     | 2    | 1     | 0 | 0                      | 0    | 0     | 0  | 1                      | 0    | 0     | 0 | 7     | 85            |
| 4:55 PM                         | 0                     | 1    | 2     | 0 | 0                     | 3    | 0     | 0 | 0                      | 0    | 0     | 1  | 2                      | 0    | 0     | 0 | 9     | 86            |
| 5:00 PM                         | 0                     | 3    | 0     | 0 | 0                     | 2    | 0     | 0 | 0                      | 0    | 0     | 1  | 0                      | 0    | 0     | 0 | 6     | 81            |
| 5:05 PM                         | 0                     | 2    | 2     | 0 | 0                     | 0    | 0     | 0 | 0                      | 0    | 0     | 0  | 2                      | 0    | 0     | 0 | 6     | 81            |
| 5:10 PM                         | 0                     | 2    | 0     | 0 | 0                     | 2    | 0     | 0 | 0                      | 0    | 0     | 0  | 0                      | 0    | 0     | 0 | 4     | 80            |
| 5:15 PM                         | 0                     | 5    | 0     | 0 | 0                     | 2    | 0     | 0 | 0                      | 0    | 0     | 2  | 0                      | 0    | 1     | 0 | 10    | 82            |
| 5:20 PM                         | 0                     | 3    | 1     | 0 | 0                     | 4    | 0     | 0 | 0                      | 0    | 0     | 1  | 2                      | 0    | 0     | 0 | 11    | 87            |
| 5:25 PM                         | 0                     | 1    | 0     | 0 | 0                     | 5    | 0     | 0 | 0                      | 0    | 0     | 0  | 1                      | 0    | 1     | 0 | 8     | 86            |
| 5:30 PM                         | 1                     | 0    | 0     | 0 | 0                     | 4    | 0     | 0 | 0                      | 0    | 0     | 0  | 0                      | 0    | 0     | 0 | 5     | 85            |
| 5:35 PM                         | 1                     | 5    | 0     | 0 | 0                     | 0    | 0     | 0 | 0                      | 0    | 0     | 0  | 0                      | 0    | 0     | 0 | 6     | 87            |
| 5:40 PM                         | 0                     | 3    | 0     | 0 | 0                     | 2    | 0     | 0 | 0                      | 0    | 0     | 0  | 1                      | 0    | 0     | 0 | 6     | 81            |
| 5:45 PM                         | 0                     | 3    | 1     | 0 | 0                     | 2    | 0     | 0 | 0                      | 0    | 0     | 0  | 2                      | 0    | 1     | 0 | 9     | 87            |
| 5:50 PM                         | 0                     | 0    | 0     | 0 | 0                     | 2    | 0     | 0 | 0                      | 0    | 0     | 0  | 1                      | 0    | 0     | 0 | 3     | 83            |
| 5:55 PM                         | 1                     | 3    | 1     | 0 | 0                     | 1    | 0     | 0 | 0                      | 0    | 0     | 0  | 0                      | 0    | 0     | 0 | 6     | 80            |
| 6:00 PM                         | 1                     | 3    | 1     | 0 | 0                     | 1    | 0     | 0 | 0                      | 0    | 0     | 0  | 4                      | 0    | 0     | 0 | 10    | 84            |
| 6:05 PM                         | 1                     | 4    | 0     | 0 | 0                     | 1    | 0     | 0 | 0                      | 0    | 0     | 0  | 0                      | 0    | 0     | 0 | 6     | 84            |
| 6:10 PM                         | 0                     | 1    | 0     | 0 | 0                     | 0    | 0     | 0 | 0                      | 0    | 0     | 0  | 0                      | 0    | 0     | 0 | 1     | 81            |
| 6:15 PM                         | 1                     | 1    | 1     | 0 | 1                     | 0    | 0     | 0 | 0                      | 0    | 0     | 0  | 0                      | 0    | 0     | 0 | 4     | 75            |
| 6:20 PM                         | 1                     | 1    | 1     | 0 | 0                     | 1    | 0     | 0 | 0                      | 0    | 0     | 0  | 0                      | 0    | 0     | 0 | 4     | 68            |
| 6:25 PM                         | 1                     | 2    | 0     | 0 | 0                     | 1    | 0     | 0 | 0                      | 0    | 0     | 2  | 0                      | 0    | 0     | 0 | 6     | 66            |
| 6:30 PM                         | 2                     | 2    | 1     | 0 | 0                     | 1    | 0     | 0 | 0                      | 0    | 0     | 1  | 0                      | 0    | 0     | 0 | 7     | 68            |
| 6:35 PM                         | 0                     | 1    | 0     | 0 | 0                     | 1    | 0     | 0 | 0                      | 0    | 0     | 0  | 1                      | 0    | 0     | 0 | 3     | 65            |
| 6:40 PM                         | 0                     | 2    | 2     | 0 | 0                     | 1    | 0     | 0 | 0                      | 0    | 0     | 2  | 0                      | 0    | 0     | 0 | 7     | 66            |
| 6:45 PM                         | 0                     | 1    | 0     | 0 | 0                     | 1    | 0     | 0 | 0                      | 0    | 0     | 0  | 1                      | 0    | 0     | 0 | 3     | 60            |
| 6:50 PM                         | 0                     | 5    | 0     | 0 | 0                     | 1    | 0     | 0 | 0                      | 0    | 0     | 1  | 0                      | 0    | 0     | 0 | 7     | 64            |
| 6:55 PM                         | 1                     | 2    | 1     | 0 | 0                     | 2    | 0     | 0 | 0                      | 0    | 0     | 1  | 0                      | 0    | 0     | 0 | 7     | 65            |
| 7:00 PM                         | 4                     | 0    | 1     | 0 | 0                     | 1    | 0     | 0 | 0                      | 0    | 0     | 0  | 0                      | 0    | 0     | 0 | 6     | 61            |
| 7:05 PM                         | 2                     | 1    | 2     | 1 | 0                     | 0    | 0     | 0 | 0                      | 0    | 0     | 0  | 0                      | 0    | 0     | 0 | 6     | 61            |
| 7:10 PM                         | 0                     | 1    | 1     | 0 | 0                     | 1    | 0     | 0 | 0                      | 0    | 0     | 0  | 0                      | 0    | 0     | 0 | 3     | 63            |
| 7:15 PM                         | 0                     | 1    | 0     | 0 | 0                     | 0    | 0     | 0 | 0                      | 0    | 0     | 0  | 1                      | 0    | 0     | 0 | 2     | 61            |
| 7:20 PM                         | 1                     | 2    | 0     | 0 | 0                     | 0    | 0     | 0 | 0                      | 0    | 0     | 2  | 0                      | 0    | 0     | 0 | 5     | 62            |
| 7:25 PM                         | 0                     | 5    | 0     | 0 | 0                     | 0    | 0     | 0 | 0                      | 0    | 0     | 0  | 0                      | 0    | 0     | 0 | 5     | 61            |
| 7:30 PM                         | 0                     | 2    | 0     | 0 | 0                     | 1    | 0     | 0 | 0                      | 0    | 0     | 0  | 0                      | 0    | 0     | 0 | 3     | 57            |
| 7:35 PM                         | 1                     | 3    | 0     | 0 | 0                     | 0    | 0     | 0 | 0                      | 0    | 0     | 0  | 1                      | 0    | 0     | 0 | 5     | 59            |
| 7:40 PM                         | 1                     | 1    | 0     | 0 | 0                     | 0    | 0     | 0 | 0                      | 0    | 0     | 0  | 0                      | 0    | 0     | 0 | 2     | 54            |
| 7:45 PM                         | 0                     | 0    | 0     | 0 | 0                     | 1    | 0     | 0 | 0                      | 0    | 0     | 0  | 0                      | 0    | 0     | 0 | 1     | 52            |
| 7:50 PM                         | 0                     | 2    | 0     | 0 | 0                     | 0    | 0     | 0 | 0                      | 0    | 0     | 2  | 0                      | 0    | 0     | 0 | 4     | 49            |
| 7:55 PM                         | 0                     | 0    | 0     | 0 | 0                     | 0    | 0     | 0 | 0                      | 0    | 0     | 0  | 1                      | 0    | 0     | 0 | 1     | 43            |
| 8:00 PM                         | 0                     | 1    | 0     | 0 | 0                     | 2    | 0     | 0 | 0                      | 0    | 0     | 0  | 0                      | 0    | 0     | 0 | 3     | 40            |
| 8:05 PM                         | 1                     | 3    | 0     | 0 | 0                     | 0    | 0     | 0 | 0                      | 0    | 0     | 0  | 1                      | 0    | 0     | 0 | 5     | 39            |
| 8:10 PM                         | 2                     | 0    | 0     | 0 | 0                     | 0    | 0     | 0 | 0                      | 0    | 0     | 0  | 0                      | 0    | 0     | 0 | 2     | 38            |
| 8:15 PM                         | 0                     | 1    | 0     | 0 | 0                     | 0    | 0     | 0 | 0                      | 0    | 0     | 0  | 0                      | 0    | 0     | 0 | 1     | 37            |
| 8:20 PM                         | 0                     | 0    | 1     | 0 | 0                     | 2    | 0     | 0 | 0                      | 0    | 0     | 1  | 0                      | 0    | 0     | 0 | 4     | 36            |
| 8:25 PM                         | 0                     | 1    | 0     | 0 | 0                     | 0    | 0     | 0 | 0                      | 0    | 0     | 0  | 0                      | 0    | 0     | 0 | 1     | 32            |
| 8:30 PM                         | 2                     | 1    | 0     | 0 | 0                     | 0    | 0     | 0 | 0                      | 0    | 0     | 1  | 0                      | 0    | 0     | 0 | 4     | 33            |
| 8:35 PM                         | 0                     | 1    | 0     | 0 | 0                     | 1    | 0     | 0 | 0                      | 0    | 0     | 0  | 1                      | 0    | 0     | 0 | 3     | 31            |
| 8:40 PM                         | 1                     | 2    | 2     | 0 | 0                     | 0    | 0     | 0 | 0                      | 0    | 0     | 0  | 0                      | 0    | 0     | 0 | 5     | 34            |
| 8:45 PM                         | 0                     | 0    | 0     | 0 | 0                     | 0    | 0     | 0 | 0                      | 0    | 0     | 0  | 0                      | 0    | 0     | 0 | 0     | 33            |
| 8:50 PM                         | 0                     | 1    | 0     | 0 | 0                     | 1    | 0     | 0 | 0                      | 0    | 0     | 0  | 0                      | 0    | 0     | 0 | 2     | 31            |
| 8:55 PM                         | 2                     | 1    | 1     | 0 | 0                     | 0    | 0     | 0 | 0                      | 0    | 0     | 1  | 0                      | 0    | 0     | 0 | 5     | 35            |
| 9:00 PM                         | 0                     | 1    | 1     | 0 | 0                     | 1    | 0     | 0 | 0                      | 0    | 0     | 0  | 0                      | 0    | 0     | 0 | 3     | 35            |
| 9:05 PM                         | 0                     | 0    | 1     | 0 | 0                     | 0    | 0     | 0 | 0                      | 0    | 0     | 2  | 0                      | 0    | 0     | 0 | 3     | 33            |
| 9:10 PM                         | 0                     | 1    | 1     | 0 | 0                     | 0    | 0     | 0 | 0                      | 0    | 0     | 0  | 1                      | 0    | 0     | 0 | 3     | 34            |
| 9:15 PM                         | 1                     | 1    | 0     | 0 | 0                     | 1    | 0     | 0 | 0                      | 0    | 0     | 0  | 0                      | 0    | 0     | 0 | 3     | 36            |
| 9:20 PM                         | 1                     | 0    | 0     | 0 | 0                     | 0    | 0     | 0 | 0                      | 0    | 0     | 0  | 0                      | 0    | 0     | 0 | 1     | 33            |
| 9:25 PM                         | 0                     | 1    | 0     | 0 | 0                     | 0    | 0     | 0 | 0                      | 0    | 0     | 0  | 0                      | 0    | 0     | 0 | 1     | 33            |
| 9:30 PM                         | 0                     | 0    | 1     | 0 | 0                     | 1    | 0     | 0 | 0                      | 0    | 0     | 0  | 1                      | 0    | 0     | 0 | 3     | 32            |
| 9:35 PM                         | 0                     | 1    | 0     | 0 | 0                     | 0    | 0     | 0 | 0                      | 0    | 0     | 0  | 0                      | 0    | 0     | 0 | 1     | 30            |
| 9:40 PM                         | 1                     | 0    | 0     | 0 | 0                     | 0    | 0     | 0 | 0                      | 0    | 0     | 0  | 0                      | 0    | 0     | 0 | 1     | 26            |
| 9:45 PM                         | 0                     | 0    | 0     | 0 | 0                     | 0    | 0     | 0 | 0                      | 0    | 0     | 0  | 0                      | 0    | 0     | 0 | 0     | 26            |
| 9:50 PM                         | 0                     | 0    | 1     | 0 | 0                     | 0    | 0     | 0 | 0                      | 0    | 0     | 0  | 0                      | 0    | 0     | 0 | 1     | 25            |
| 9:55 PM                         | 0                     | 0    | 0     | 0 | 0                     | 0    | 0     | 0 | 0                      | 0    | 0     | 0  | 0                      | 0    | 0     | 0 | 0     | 20            |
| Peak 15-Min Flowrates           | Northbound            |      |       |   | Southbound            |      |       |   | Eastbound              |      |       |    | Westbound              |      |       |   | Total |               |
|                                 | Left                  | Thru | Right | U | Left                  | Thru | Right | U | Left                   | Thru | Right | U  | Left                   | Thru | Right | U |       |               |
| All Vehicles                    | 0                     | 28   | 12    | 0 | 0                     | 60   | 0     | 0 | 0                      | 0    | 0     | 20 | 0                      | 4    | 0     | 0 | 0     | 124           |
| Heavy Trucks                    | 0                     | 0    | 0     |   | 0                     | 0    | 0     |   | 0                      | 0    | 0     |    | 0                      | 0    | 0     |   | 0     | 0             |
| Buses                           |                       |      |       |   |                       |      |       |   |                        |      |       |    |                        |      |       |   |       | 0             |
| Pedestrians                     |                       | 0    |       |   |                       | 0    |       |   |                        | 0    |       |    |                        | 0    |       |   |       | 0             |
| Bicycles                        | 0                     | 0    | 0     |   | 0                     | 0    | 0     |   | 0                      | 0    | 0     |    | 0                      | 0    | 0     |   | 0     | 0             |
| Scoters                         |                       |      |       |   |                       |      |       |   |                        |      |       |    |                        |      |       |   |       | 0             |
| <i>Comments:</i>                |                       |      |       |   |                       |      |       |   |                        |      |       |    |                        |      |       |   |       |               |

Type of peak hour being reported: Intersection Peak

Method for determining peak hour: Total Entering Volume

LOCATION: Woodsong -- Wildemere  
 CITY/STATE: Las Flores, CA

QC JOB #: 16966453  
 DATE: Wed, Apr 16 2025

Peak-Hour: 7:15 AM -- 8:15 AM  
 Peak 15-Min: 7:55 AM -- 8:10 AM

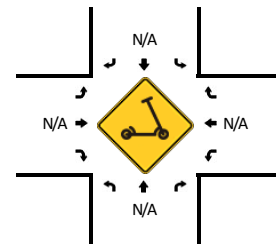
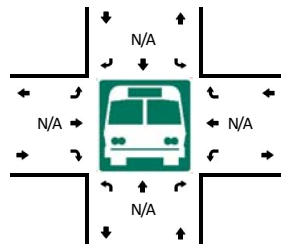
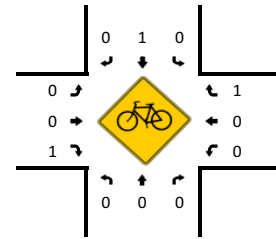
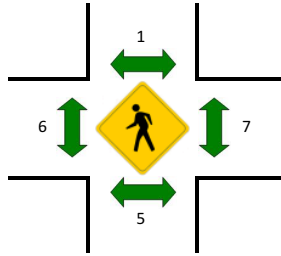
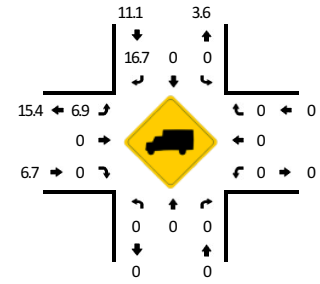
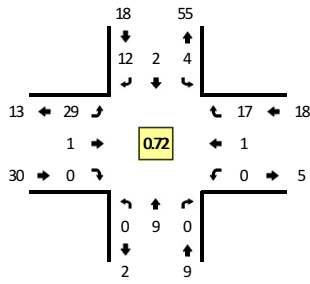

| 5-Min Count Period Beginning At | Woodsong (Northbound) |      |       |   | Woodsong (Southbound) |      |       |   | Wildemere (Eastbound) |      |       |   | Wildemere (Westbound) |      |       |   | Total | Hourly Totals |
|---------------------------------|-----------------------|------|-------|---|-----------------------|------|-------|---|-----------------------|------|-------|---|-----------------------|------|-------|---|-------|---------------|
|                                 | Left                  | Thru | Right | U | Left                  | Thru | Right | U | Left                  | Thru | Right | U | Left                  | Thru | Right | U |       |               |
| 6:00 AM                         | 0                     | 0    | 0     | 0 | 0                     | 0    | 0     | 0 | 1                     | 0    | 0     | 0 | 0                     | 0    | 1     | 0 | 2     |               |
| 6:05 AM                         | 0                     | 0    | 0     | 0 | 0                     | 0    | 0     | 0 | 0                     | 0    | 0     | 0 | 0                     | 0    | 0     | 0 | 0     |               |
| 6:10 AM                         | 0                     | 0    | 0     | 0 | 0                     | 0    | 0     | 0 | 0                     | 0    | 0     | 0 | 0                     | 0    | 0     | 0 | 0     |               |
| 6:15 AM                         | 0                     | 0    | 0     | 0 | 0                     | 0    | 0     | 0 | 1                     | 0    | 0     | 0 | 0                     | 0    | 1     | 0 | 2     |               |
| 6:20 AM                         | 0                     | 0    | 0     | 0 | 1                     | 0    | 0     | 0 | 0                     | 0    | 0     | 0 | 0                     | 0    | 0     | 0 | 1     |               |
| 6:25 AM                         | 0                     | 2    | 0     | 0 | 0                     | 0    | 0     | 0 | 1                     | 0    | 0     | 0 | 0                     | 0    | 0     | 0 | 3     |               |
| 6:30 AM                         | 0                     | 1    | 1     | 0 | 0                     | 0    | 1     | 0 | 0                     | 0    | 1     | 0 | 0                     | 0    | 0     | 0 | 4     |               |
| 6:35 AM                         | 0                     | 1    | 0     | 0 | 0                     | 0    | 0     | 0 | 1                     | 0    | 0     | 0 | 0                     | 0    | 1     | 0 | 3     |               |
| 6:40 AM                         | 0                     | 0    | 0     | 0 | 0                     | 0    | 0     | 0 | 0                     | 0    | 0     | 0 | 0                     | 0    | 0     | 0 | 0     |               |
| 6:45 AM                         | 0                     | 0    | 0     | 0 | 0                     | 1    | 0     | 0 | 1                     | 0    | 0     | 0 | 0                     | 0    | 0     | 0 | 2     |               |
| 6:50 AM                         | 0                     | 1    | 0     | 0 | 1                     | 0    | 0     | 0 | 2                     | 0    | 0     | 0 | 0                     | 0    | 0     | 0 | 4     |               |
| 6:55 AM                         | 0                     | 0    | 0     | 0 | 0                     | 0    | 0     | 0 | 0                     | 0    | 0     | 0 | 0                     | 0    | 2     | 0 | 2     | 23            |
| 7:00 AM                         | 0                     | 1    | 0     | 0 | 0                     | 0    | 0     | 0 | 2                     | 0    | 0     | 0 | 0                     | 0    | 0     | 0 | 3     | 24            |
| 7:05 AM                         | 0                     | 0    | 0     | 0 | 0                     | 0    | 1     | 0 | 2                     | 0    | 0     | 0 | 0                     | 0    | 0     | 0 | 3     | 27            |
| 7:10 AM                         | 0                     | 0    | 0     | 0 | 0                     | 0    | 0     | 0 | 0                     | 0    | 0     | 0 | 0                     | 0    | 1     | 0 | 1     | 28            |
| 7:15 AM                         | 0                     | 1    | 0     | 0 | 0                     | 0    | 0     | 0 | 1                     | 0    | 0     | 0 | 0                     | 0    | 1     | 0 | 3     | 29            |
| 7:20 AM                         | 0                     | 1    | 0     | 0 | 0                     | 0    | 1     | 0 | 2                     | 0    | 0     | 0 | 0                     | 0    | 2     | 0 | 6     | 34            |
| 7:25 AM                         | 0                     | 1    | 0     | 0 | 1                     | 0    | 2     | 0 | 1                     | 0    | 0     | 0 | 0                     | 0    | 2     | 0 | 7     | 38            |
| 7:30 AM                         | 0                     | 0    | 0     | 0 | 0                     | 0    | 1     | 0 | 3                     | 0    | 0     | 0 | 0                     | 0    | 1     | 0 | 5     | 39            |
| 7:35 AM                         | 0                     | 0    | 0     | 0 | 0                     | 0    | 1     | 0 | 2                     | 0    | 0     | 0 | 0                     | 0    | 1     | 0 | 4     | 40            |
| 7:40 AM                         | 0                     | 3    | 0     | 0 | 1                     | 0    | 1     | 0 | 2                     | 0    | 0     | 0 | 0                     | 0    | 1     | 0 | 8     | 48            |
| 7:45 AM                         | 0                     | 0    | 0     | 0 | 0                     | 1    | 1     | 0 | 1                     | 0    | 0     | 0 | 0                     | 0    | 0     | 0 | 3     | 49            |
| 7:50 AM                         | 0                     | 1    | 0     | 0 | 0                     | 0    | 0     | 0 | 4                     | 0    | 0     | 0 | 0                     | 0    | 2     | 0 | 7     | 52            |
| 7:55 AM                         | 0                     | 0    | 0     | 0 | 1                     | 1    | 4     | 0 | 4                     | 0    | 0     | 0 | 0                     | 1    | 1     | 0 | 12    | 62            |
| 8:00 AM                         | 0                     | 1    | 0     | 0 | 0                     | 0    | 0     | 0 | 2                     | 0    | 0     | 0 | 0                     | 0    | 3     | 0 | 6     | 65            |
| 8:05 AM                         | 0                     | 1    | 0     | 0 | 1                     | 0    | 1     | 0 | 3                     | 0    | 0     | 0 | 0                     | 0    | 2     | 0 | 8     | 70            |
| 8:10 AM                         | 0                     | 0    | 0     | 0 | 0                     | 0    | 0     | 0 | 4                     | 1    | 0     | 0 | 0                     | 0    | 1     | 0 | 6     | 75            |
| 8:15 AM                         | 0                     | 0    | 0     | 0 | 0                     | 1    | 0     | 0 | 1                     | 0    | 0     | 0 | 0                     | 0    | 1     | 0 | 3     | 75            |
| 8:20 AM                         | 0                     | 0    | 0     | 0 | 1                     | 0    | 0     | 0 | 0                     | 0    | 0     | 0 | 0                     | 0    | 1     | 0 | 2     | 71            |
| 8:25 AM                         | 0                     | 0    | 0     | 0 | 1                     | 0    | 1     | 0 | 0                     | 0    | 0     | 0 | 0                     | 0    | 1     | 0 | 3     | 67            |
| 8:30 AM                         | 0                     | 1    | 0     | 0 | 3                     | 0    | 0     | 0 | 1                     | 0    | 0     | 0 | 0                     | 0    | 0     | 0 | 5     | 67            |
| 8:35 AM                         | 0                     | 0    | 0     | 0 | 1                     | 0    | 0     | 0 | 1                     | 0    | 0     | 0 | 0                     | 0    | 1     | 0 | 3     | 66            |
| 8:40 AM                         | 0                     | 0    | 0     | 0 | 0                     | 0    | 0     | 0 | 0                     | 0    | 0     | 0 | 0                     | 0    | 1     | 0 | 1     | 59            |
| 8:45 AM                         | 0                     | 0    | 0     | 0 | 2                     | 0    | 0     | 0 | 0                     | 0    | 0     | 0 | 0                     | 0    | 3     | 0 | 5     | 61            |
| 8:50 AM                         | 0                     | 0    | 0     | 0 | 1                     | 0    | 2     | 0 | 0                     | 0    | 0     | 0 | 0                     | 0    | 0     | 0 | 3     | 57            |
| 8:55 AM                         | 0                     | 1    | 0     | 0 | 0                     | 0    | 0     | 0 | 0                     | 0    | 0     | 0 | 0                     | 0    | 3     | 0 | 4     | 49            |
| 9:00 AM                         | 0                     | 1    | 0     | 0 | 0                     | 0    | 0     | 0 | 1                     | 0    | 0     | 0 | 0                     | 0    | 0     | 0 | 2     | 45            |
| 9:05 AM                         | 0                     | 1    | 0     | 0 | 0                     | 0    | 1     | 0 | 0                     | 0    | 0     | 0 | 0                     | 0    | 2     | 0 | 4     | 41            |

**Attachment B**

| 5-Min Count Period Beginning At | Woodsong (Northbound) |      |       |   | Woodsong (Southbound) |      |       |   | Wildemere (Eastbound) |      |       |   | Wildemere (Westbound) |      |       |   | Total | Hourly Totals |
|---------------------------------|-----------------------|------|-------|---|-----------------------|------|-------|---|-----------------------|------|-------|---|-----------------------|------|-------|---|-------|---------------|
|                                 | Left                  | Thru | Right | U | Left                  | Thru | Right | U | Left                  | Thru | Right | U | Left                  | Thru | Right | U |       |               |
| 9:10 AM                         | 0                     | 1    | 0     | 0 | 0                     | 1    | 1     | 0 | 1                     | 0    | 0     | 0 | 0                     | 0    | 0     | 0 | 4     | 39            |
| 9:15 AM                         | 0                     | 1    | 0     | 0 | 0                     | 0    | 1     | 0 | 1                     | 0    | 0     | 0 | 0                     | 0    | 0     | 0 | 3     | 39            |
| 9:20 AM                         | 0                     | 1    | 0     | 0 | 0                     | 1    | 0     | 0 | 1                     | 0    | 0     | 0 | 0                     | 0    | 1     | 0 | 4     | 41            |
| 9:25 AM                         | 0                     | 1    | 0     | 0 | 0                     | 0    | 1     | 0 | 1                     | 0    | 0     | 0 | 0                     | 0    | 0     | 0 | 3     | 41            |
| 9:30 AM                         | 0                     | 0    | 0     | 0 | 0                     | 0    | 0     | 0 | 0                     | 0    | 0     | 0 | 0                     | 0    | 0     | 0 | 0     | 36            |
| 9:35 AM                         | 0                     | 1    | 0     | 0 | 0                     | 0    | 0     | 0 | 1                     | 0    | 0     | 0 | 0                     | 0    | 1     | 0 | 3     | 36            |
| 9:40 AM                         | 0                     | 0    | 0     | 0 | 1                     | 1    | 1     | 0 | 1                     | 0    | 0     | 0 | 0                     | 0    | 0     | 0 | 4     | 39            |
| 9:45 AM                         | 0                     | 1    | 0     | 0 | 0                     | 0    | 0     | 0 | 2                     | 0    | 0     | 0 | 0                     | 0    | 2     | 0 | 5     | 39            |
| 9:50 AM                         | 0                     | 0    | 0     | 0 | 0                     | 1    | 0     | 0 | 0                     | 0    | 0     | 0 | 0                     | 0    | 0     | 0 | 1     | 37            |
| 9:55 AM                         | 0                     | 2    | 0     | 0 | 0                     | 0    | 1     | 0 | 1                     | 0    | 0     | 0 | 0                     | 0    | 0     | 0 | 4     | 37            |
| 10:00 AM                        | 0                     | 0    | 0     | 0 | 0                     | 0    | 1     | 0 | 0                     | 0    | 0     | 0 | 0                     | 0    | 1     | 0 | 2     | 37            |
| 10:05 AM                        | 0                     | 1    | 0     | 0 | 0                     | 0    | 0     | 0 | 1                     | 0    | 0     | 0 | 0                     | 0    | 0     | 0 | 2     | 35            |
| 10:10 AM                        | 0                     | 0    | 0     | 0 | 0                     | 0    | 1     | 0 | 0                     | 0    | 0     | 0 | 0                     | 0    | 0     | 0 | 1     | 32            |
| 10:15 AM                        | 0                     | 0    | 0     | 0 | 1                     | 0    | 0     | 0 | 1                     | 0    | 0     | 0 | 0                     | 0    | 0     | 0 | 2     | 31            |
| 10:20 AM                        | 0                     | 0    | 0     | 0 | 1                     | 1    | 1     | 0 | 0                     | 0    | 0     | 0 | 0                     | 0    | 1     | 0 | 4     | 31            |
| 10:25 AM                        | 0                     | 0    | 0     | 0 | 0                     | 0    | 0     | 0 | 0                     | 0    | 0     | 0 | 0                     | 0    | 0     | 0 | 0     | 28            |
| 10:30 AM                        | 0                     | 1    | 0     | 0 | 0                     | 1    | 0     | 0 | 0                     | 0    | 0     | 0 | 0                     | 0    | 1     | 0 | 3     | 31            |
| 10:35 AM                        | 0                     | 1    | 0     | 0 | 0                     | 1    | 0     | 0 | 0                     | 0    | 0     | 0 | 0                     | 0    | 0     | 0 | 2     | 30            |
| 10:40 AM                        | 0                     | 0    | 0     | 0 | 0                     | 0    | 0     | 0 | 0                     | 0    | 0     | 0 | 0                     | 0    | 0     | 0 | 0     | 26            |
| 10:45 AM                        | 0                     | 0    | 0     | 0 | 0                     | 1    | 1     | 0 | 0                     | 1    | 0     | 0 | 0                     | 0    | 1     | 0 | 4     | 25            |
| 10:50 AM                        | 0                     | 0    | 0     | 0 | 0                     | 0    | 0     | 0 | 3                     | 0    | 0     | 0 | 0                     | 0    | 1     | 0 | 4     | 28            |
| 10:55 AM                        | 0                     | 0    | 0     | 0 | 0                     | 0    | 0     | 0 | 0                     | 0    | 0     | 0 | 0                     | 0    | 1     | 0 | 1     | 25            |
| 11:00 AM                        | 0                     | 0    | 0     | 0 | 0                     | 0    | 0     | 0 | 1                     | 0    | 0     | 0 | 0                     | 0    | 0     | 0 | 1     | 24            |
| 11:05 AM                        | 0                     | 1    | 0     | 0 | 0                     | 0    | 3     | 0 | 3                     | 0    | 0     | 0 | 0                     | 0    | 0     | 0 | 7     | 29            |
| 11:10 AM                        | 0                     | 0    | 0     | 0 | 2                     | 0    | 0     | 0 | 0                     | 0    | 0     | 0 | 0                     | 0    | 1     | 0 | 3     | 31            |
| 11:15 AM                        | 0                     | 0    | 0     | 0 | 0                     | 1    | 0     | 0 | 1                     | 0    | 0     | 0 | 0                     | 0    | 0     | 0 | 2     | 31            |
| 11:20 AM                        | 0                     | 1    | 0     | 0 | 0                     | 2    | 2     | 0 | 0                     | 0    | 0     | 0 | 0                     | 0    | 0     | 0 | 5     | 32            |
| 11:25 AM                        | 0                     | 1    | 0     | 0 | 0                     | 0    | 0     | 0 | 1                     | 0    | 0     | 0 | 0                     | 0    | 0     | 0 | 2     | 34            |
| 11:30 AM                        | 0                     | 0    | 0     | 0 | 0                     | 0    | 0     | 0 | 0                     | 0    | 0     | 0 | 0                     | 0    | 1     | 0 | 1     | 32            |
| 11:35 AM                        | 0                     | 1    | 0     | 0 | 1                     | 0    | 1     | 0 | 0                     | 0    | 0     | 0 | 0                     | 0    | 1     | 0 | 4     | 34            |
| 11:40 AM                        | 0                     | 0    | 0     | 0 | 0                     | 0    | 1     | 0 | 0                     | 1    | 0     | 0 | 0                     | 0    | 1     | 0 | 3     | 37            |
| 11:45 AM                        | 0                     | 0    | 0     | 0 | 1                     | 0    | 0     | 0 | 0                     | 0    | 0     | 0 | 0                     | 0    | 0     | 0 | 1     | 34            |
| 11:50 AM                        | 0                     | 0    | 0     | 0 | 0                     | 0    | 0     | 0 | 1                     | 0    | 0     | 0 | 0                     | 0    | 0     | 0 | 1     | 31            |
| 11:55 AM                        | 0                     | 0    | 0     | 0 | 3                     | 0    | 0     | 0 | 1                     | 0    | 0     | 0 | 0                     | 0    | 2     | 0 | 6     | 36            |
| 12:00 PM                        | 0                     | 0    | 0     | 0 | 0                     | 1    | 0     | 0 | 0                     | 0    | 0     | 0 | 0                     | 0    | 0     | 0 | 1     | 36            |
| 12:05 PM                        | 0                     | 2    | 0     | 0 | 1                     | 1    | 0     | 0 | 0                     | 0    | 0     | 0 | 0                     | 0    | 0     | 0 | 4     | 33            |
| 12:10 PM                        | 0                     | 0    | 0     | 0 | 2                     | 2    | 1     | 0 | 2                     | 0    | 0     | 0 | 0                     | 0    | 0     | 0 | 7     | 37            |
| 12:15 PM                        | 0                     | 0    | 0     | 0 | 1                     | 1    | 1     | 0 | 0                     | 0    | 0     | 0 | 0                     | 0    | 0     | 0 | 3     | 38            |
| 12:20 PM                        | 0                     | 0    | 0     | 0 | 0                     | 0    | 0     | 0 | 0                     | 0    | 0     | 0 | 0                     | 0    | 0     | 0 | 0     | 33            |
| 12:25 PM                        | 0                     | 0    | 0     | 0 | 1                     | 0    | 2     | 0 | 0                     | 0    | 0     | 0 | 0                     | 0    | 0     | 0 | 3     | 34            |
| 12:30 PM                        | 0                     | 0    | 0     | 0 | 1                     | 0    | 0     | 0 | 0                     | 0    | 0     | 0 | 0                     | 0    | 1     | 0 | 2     | 35            |
| 12:35 PM                        | 0                     | 1    | 0     | 0 | 0                     | 0    | 1     | 0 | 1                     | 0    | 0     | 0 | 0                     | 0    | 0     | 0 | 3     | 34            |
| 12:40 PM                        | 0                     | 0    | 0     | 0 | 0                     | 0    | 0     | 0 | 0                     | 0    | 0     | 0 | 0                     | 0    | 0     | 0 | 0     | 31            |
| 12:45 PM                        | 0                     | 0    | 0     | 0 | 0                     | 0    | 1     | 0 | 0                     | 0    | 0     | 0 | 0                     | 0    | 0     | 0 | 1     | 31            |
| 12:50 PM                        | 0                     | 1    | 0     | 0 | 0                     | 1    | 0     | 0 | 1                     | 0    | 0     | 0 | 0                     | 0    | 1     | 0 | 4     | 34            |
| 12:55 PM                        | 0                     | 0    | 0     | 0 | 1                     | 0    | 0     | 0 | 0                     | 0    | 0     | 0 | 0                     | 0    | 0     | 0 | 1     | 29            |
| 1:00 PM                         | 0                     | 0    | 0     | 0 | 0                     | 0    | 3     | 0 | 2                     | 0    | 0     | 0 | 0                     | 0    | 0     | 0 | 5     | 33            |
| 1:05 PM                         | 0                     | 0    | 0     | 0 | 1                     | 0    | 1     | 0 | 1                     | 0    | 0     | 0 | 0                     | 0    | 4     | 0 | 7     | 36            |
| 1:10 PM                         | 0                     | 1    | 0     | 0 | 0                     | 0    | 0     | 0 | 0                     | 0    | 0     | 0 | 0                     | 0    | 0     | 0 | 1     | 30            |
| 1:15 PM                         | 0                     | 0    | 0     | 0 | 0                     | 0    | 0     | 0 | 1                     | 0    | 0     | 0 | 0                     | 0    | 2     | 0 | 3     | 30            |
| 1:20 PM                         | 0                     | 1    | 0     | 0 | 0                     | 1    | 0     | 0 | 0                     | 0    | 0     | 0 | 0                     | 0    | 0     | 0 | 2     | 32            |
| 1:25 PM                         | 0                     | 0    | 0     | 0 | 0                     | 0    | 0     | 0 | 1                     | 0    | 0     | 0 | 0                     | 0    | 0     | 0 | 1     | 30            |
| 1:30 PM                         | 0                     | 0    | 0     | 0 | 2                     | 2    | 1     | 0 | 1                     | 0    | 0     | 0 | 0                     | 0    | 0     | 0 | 6     | 34            |
| 1:35 PM                         | 0                     | 0    | 0     | 0 | 0                     | 0    | 0     | 0 | 1                     | 0    | 0     | 0 | 0                     | 0    | 2     | 0 | 3     | 34            |
| 1:40 PM                         | 0                     | 0    | 0     | 0 | 0                     | 1    | 0     | 0 | 2                     | 0    | 0     | 0 | 0                     | 0    | 0     | 0 | 3     | 37            |
| 1:45 PM                         | 0                     | 1    | 0     | 0 | 0                     | 0    | 0     | 0 | 0                     | 0    | 0     | 0 | 0                     | 0    | 0     | 0 | 1     | 37            |
| 1:50 PM                         | 0                     | 0    | 0     | 0 | 0                     | 0    | 1     | 0 | 0                     | 0    | 0     | 0 | 0                     | 0    | 1     | 0 | 2     | 35            |
| 1:55 PM                         | 0                     | 2    | 0     | 0 | 0                     | 0    | 0     | 0 | 0                     | 0    | 1     | 0 | 0                     | 0    | 0     | 0 | 3     | 37            |
| 2:00 PM                         | 0                     | 2    | 0     | 0 | 1                     | 0    | 4     | 0 | 0                     | 0    | 0     | 0 | 0                     | 0    | 0     | 0 | 7     | 39            |
| 2:05 PM                         | 0                     | 1    | 0     | 0 | 0                     | 0    | 0     | 0 | 0                     | 0    | 0     | 0 | 0                     | 0    | 2     | 0 | 3     | 35            |
| 2:10 PM                         | 0                     | 0    | 0     | 0 | 0                     | 1    | 2     | 0 | 0                     | 0    | 0     | 0 | 0                     | 0    | 0     | 0 | 3     | 37            |
| 2:15 PM                         | 0                     | 1    | 0     | 0 | 2                     | 0    | 0     | 0 | 4                     | 0    | 0     | 0 | 0                     | 0    | 0     | 0 | 7     | 41            |
| 2:20 PM                         | 0                     | 0    | 0     | 0 | 0                     | 0    | 0     | 0 | 3                     | 0    | 1     | 0 | 0                     | 0    | 1     | 0 | 5     | 44            |
| 2:25 PM                         | 0                     | 1    | 0     | 0 | 1                     | 1    | 1     | 0 | 1                     | 0    | 0     | 0 | 0                     | 0    | 0     | 0 | 5     | 48            |
| 2:30 PM                         | 0                     | 0    | 0     | 0 | 2                     | 0    | 2     | 0 | 2                     | 0    | 0     | 0 | 0                     | 0    | 1     | 0 | 7     | 49            |
| 2:35 PM                         | 0                     | 0    | 0     | 0 | 0                     | 1    | 0     | 0 | 0                     | 0    | 0     | 0 | 0                     | 0    | 0     | 0 | 1     | 47            |
| 2:40 PM                         | 0                     | 1    | 0     | 0 | 1                     | 1    | 1     | 0 | 0                     | 0    | 0     | 0 | 0                     | 0    | 2     | 0 | 6     | 50            |
| 2:45 PM                         | 0                     | 0    | 0     | 0 | 2                     | 1    | 1     | 0 | 0                     | 0    | 0     | 0 | 0                     | 0    | 0     | 0 | 4     | 53            |
| 2:50 PM                         | 0                     | 1    | 0     | 0 | 0                     | 0    | 2     | 1 | 0                     | 0    | 0     | 0 | 0                     | 0    | 1     | 0 | 5     | 56            |
| 2:55 PM                         | 0                     | 1    | 0     | 0 | 2                     | 1    | 1     | 0 | 0                     | 0    | 0     | 0 | 0                     | 0    | 1     | 0 | 6     | 59            |
| 3:00 PM                         | 0                     | 1    | 0     | 0 | 0                     | 0    | 1     | 0 | 1                     | 0    | 1     | 0 | 0                     | 0    | 1     | 0 | 5     | 57            |
| 3:05 PM                         | 0                     | 0    | 0     | 0 | 0                     | 0    | 0     | 0 | 1                     | 0    | 0     | 0 | 0                     | 0    | 2     | 0 | 3     | 57            |
| 3:10 PM                         | 0                     | 0    | 0     | 0 | 1                     | 2    | 3     | 0 | 1                     | 0    | 0     | 0 | 0                     | 0    | 0     | 0 | 7     | 61            |
| 3:15 PM                         | 0                     | 0    | 0     | 0 | 1                     | 0    | 1     | 0 | 1                     | 1    | 0     | 0 | 0                     | 0    | 0     | 0 | 4     | 58            |
| 3:20 PM                         | 0                     | 0    | 0     | 0 | 2                     | 0    | 3     | 0 | 1                     | 0    | 0     | 0 | 1                     | 0    | 0     | 0 | 7     | 60            |
| 3:25 PM                         | 0                     | 1    | 0     | 0 | 1                     | 2    | 2     | 0 | 0                     | 0    | 0     | 0 | 0                     | 0    | 2     | 0 | 8     | 63            |
| 3:30 PM                         | 1                     | 0    | 0     | 0 | 2                     | 0    | 1     | 0 | 1                     | 0    | 0     | 0 | 0                     | 0    | 0     | 0 | 5     | 61            |
| 3:35 PM                         | 0                     | 3    | 0     | 0 | 0                     | 1    | 2     | 0 | 0                     | 0    | 0     | 0 | 0                     | 0    | 1     | 0 | 7     | 67            |
| 3:40 PM                         | 0                     | 1    | 0     | 0 | 1                     | 2    | 1     | 0 | 2                     | 0    | 0     | 0 | 0                     | 0    | 0     | 0 | 7     | 68            |
| 3:45 PM                         | 0                     | 0    | 0     | 0 | 1                     | 0    | 0     | 0 | 0                     | 1    | 0     | 0 | 0                     | 0    | 0     | 0 | 2     | 66            |
| 3:50 PM                         | 0                     | 0    | 0     | 0 | 1                     | 0    | 2     | 0 | 0                     | 0    | 0     | 0 | 0                     | 0    | 0     | 0 | 3     | 64            |
| 3:55 PM                         | 0                     | 1    | 0     | 0 | 1                     | 2    | 1     | 0 | 1                     | 0    | 0     | 0 | 0                     | 0    | 1     | 0 | 7     | 65            |
| 4:00 PM                         | 0                     | 2    | 0     | 0 | 2                     | 0    | 1     | 0 | 1                     | 0    | 0     | 0 | 0                     | 1    | 0     | 0 | 7     | 67            |
| 4:05 PM                         | 0                     | 1    | 0     | 0 | 1                     | 0    | 1     | 0 | 1                     | 0    | 0     | 0 | 0                     | 0    | 1     | 0 | 5     | 69            |
| 4:10 PM                         | 0                     | 0    | 0     | 0 | 2                     | 0    | 2     | 0 | 1                     | 0    | 0     | 0 | 0                     | 0    | 1     | 0 | 6     | 68            |
| 4:15 PM                         | 0                     | 0    | 0     | 0 | 1                     | 0    | 1     | 0 | 0                     | 0    | 0     | 0 | 0                     | 0    | 0     | 0 | 2     | 66            |
| 4:20 PM                         | 0                     | 1    | 0     | 0 | 2                     | 0    | 1     | 0 | 0                     | 0    | 0     | 0 | 0                     | 0    | 0     | 0 | 4     | 63            |
| 4:25 PM                         | 0                     | 0    | 0     | 0 | 0                     | 0    | 0     | 0 | 1                     | 0    | 0     | 0 | 0                     | 0    | 1     | 0 | 2     | 57            |
| 4:30 PM                         | 0                     | 0    | 0     | 0 | 1                     | 0    | 1     | 0 | 0                     | 0    | 0     | 0 | 0                     | 0    | 4     | 0 | 6     | 58            |

## Attachment B

| 5-Min Count Period Beginning At | Woodsong (Northbound) |      |       |   | Woodsong (Southbound) |      |       |   | Wildemere (Eastbound) |      |       |   | Wildemere (Westbound) |      |       |   | Total | Hourly Totals |
|---------------------------------|-----------------------|------|-------|---|-----------------------|------|-------|---|-----------------------|------|-------|---|-----------------------|------|-------|---|-------|---------------|
|                                 | Left                  | Thru | Right | U | Left                  | Thru | Right | U | Left                  | Thru | Right | U | Left                  | Thru | Right | U |       |               |
| 4:35 PM                         | 0                     | 0    | 0     | 0 | 0                     | 2    | 0     | 0 | 1                     | 0    | 0     | 0 | 0                     | 0    | 0     | 0 | 3     | 54            |
| 4:40 PM                         | 0                     | 0    | 0     | 0 | 0                     | 1    | 1     | 0 | 2                     | 0    | 0     | 0 | 0                     | 0    | 0     | 0 | 4     | 51            |
| 4:45 PM                         | 0                     | 1    | 0     | 0 | 0                     | 0    | 1     | 0 | 0                     | 0    | 0     | 0 | 0                     | 0    | 0     | 0 | 2     | 51            |
| 4:50 PM                         | 0                     | 0    | 0     | 0 | 2                     | 1    | 0     | 0 | 1                     | 0    | 0     | 0 | 0                     | 0    | 0     | 0 | 4     | 52            |
| 4:55 PM                         | 0                     | 0    | 0     | 0 | 2                     | 1    | 1     | 0 | 0                     | 0    | 0     | 0 | 0                     | 0    | 0     | 0 | 4     | 49            |
| 5:00 PM                         | 0                     | 0    | 0     | 0 | 0                     | 0    | 1     | 0 | 1                     | 0    | 0     | 0 | 0                     | 0    | 0     | 0 | 2     | 44            |
| 5:05 PM                         | 0                     | 1    | 1     | 0 | 0                     | 2    | 4     | 0 | 0                     | 0    | 0     | 0 | 0                     | 0    | 1     | 0 | 9     | 48            |
| 5:10 PM                         | 0                     | 0    | 0     | 0 | 2                     | 2    | 1     | 0 | 4                     | 0    | 0     | 0 | 0                     | 1    | 0     | 0 | 10    | 52            |
| 5:15 PM                         | 0                     | 1    | 1     | 0 | 1                     | 0    | 0     | 0 | 1                     | 0    | 1     | 0 | 0                     | 0    | 3     | 0 | 8     | 58            |
| 5:20 PM                         | 0                     | 0    | 0     | 0 | 1                     | 1    | 4     | 0 | 1                     | 0    | 0     | 0 | 0                     | 0    | 1     | 0 | 8     | 62            |
| 5:25 PM                         | 0                     | 0    | 0     | 0 | 1                     | 1    | 5     | 0 | 2                     | 0    | 0     | 0 | 0                     | 0    | 0     | 0 | 9     | 69            |
| 5:30 PM                         | 0                     | 0    | 0     | 0 | 1                     | 1    | 0     | 0 | 0                     | 0    | 0     | 0 | 0                     | 0    | 0     | 0 | 2     | 65            |
| 5:35 PM                         | 0                     | 0    | 0     | 0 | 0                     | 1    | 2     | 0 | 0                     | 0    | 0     | 0 | 0                     | 0    | 1     | 0 | 4     | 66            |
| 5:40 PM                         | 0                     | 0    | 0     | 0 | 1                     | 0    | 2     | 0 | 0                     | 0    | 0     | 0 | 0                     | 0    | 1     | 0 | 4     | 66            |
| 5:45 PM                         | 0                     | 0    | 0     | 0 | 1                     | 0    | 0     | 0 | 0                     | 0    | 0     | 0 | 0                     | 0    | 0     | 0 | 1     | 65            |
| 5:50 PM                         | 0                     | 2    | 0     | 0 | 1                     | 1    | 0     | 0 | 1                     | 0    | 0     | 0 | 0                     | 0    | 1     | 0 | 6     | 67            |
| 5:55 PM                         | 0                     | 2    | 0     | 0 | 2                     | 2    | 1     | 0 | 0                     | 0    | 0     | 0 | 0                     | 0    | 0     | 0 | 7     | 70            |
| 6:00 PM                         | 0                     | 0    | 0     | 0 | 2                     | 3    | 1     | 0 | 0                     | 0    | 0     | 0 | 0                     | 0    | 1     | 0 | 7     | 75            |
| 6:05 PM                         | 0                     | 0    | 0     | 0 | 0                     | 1    | 3     | 0 | 2                     | 0    | 0     | 0 | 0                     | 0    | 1     | 0 | 7     | 73            |
| 6:10 PM                         | 0                     | 0    | 0     | 0 | 2                     | 0    | 1     | 0 | 1                     | 0    | 0     | 0 | 0                     | 0    | 0     | 0 | 4     | 67            |
| 6:15 PM                         | 0                     | 0    | 0     | 0 | 0                     | 1    | 2     | 0 | 0                     | 0    | 0     | 0 | 0                     | 0    | 0     | 0 | 3     | 62            |
| 6:20 PM                         | 0                     | 0    | 0     | 0 | 2                     | 1    | 2     | 0 | 0                     | 0    | 0     | 0 | 0                     | 0    | 1     | 0 | 6     | 60            |
| 6:25 PM                         | 0                     | 0    | 0     | 0 | 0                     | 1    | 0     | 0 | 1                     | 0    | 0     | 0 | 0                     | 0    | 0     | 0 | 2     | 53            |
| 6:30 PM                         | 0                     | 0    | 0     | 0 | 1                     | 0    | 0     | 0 | 1                     | 0    | 0     | 0 | 0                     | 0    | 0     | 0 | 2     | 53            |
| 6:35 PM                         | 0                     | 0    | 0     | 0 | 3                     | 1    | 0     | 0 | 0                     | 0    | 0     | 0 | 0                     | 0    | 2     | 0 | 6     | 55            |
| 6:40 PM                         | 0                     | 0    | 0     | 0 | 0                     | 0    | 0     | 0 | 1                     | 0    | 0     | 0 | 0                     | 0    | 2     | 0 | 3     | 54            |
| 6:45 PM                         | 0                     | 0    | 0     | 0 | 1                     | 0    | 0     | 0 | 0                     | 0    | 0     | 0 | 0                     | 0    | 1     | 0 | 2     | 55            |
| 6:50 PM                         | 0                     | 1    | 0     | 0 | 3                     | 1    | 0     | 0 | 0                     | 0    | 0     | 0 | 0                     | 0    | 1     | 0 | 6     | 55            |
| 6:55 PM                         | 0                     | 1    | 0     | 0 | 1                     | 0    | 0     | 0 | 0                     | 0    | 0     | 0 | 0                     | 0    | 1     | 0 | 3     | 51            |
| 7:00 PM                         | 0                     | 0    | 0     | 0 | 1                     | 1    | 0     | 0 | 0                     | 0    | 0     | 0 | 0                     | 0    | 0     | 0 | 2     | 46            |
| 7:05 PM                         | 0                     | 1    | 0     | 0 | 0                     | 0    | 1     | 0 | 1                     | 0    | 0     | 0 | 0                     | 0    | 0     | 0 | 3     | 42            |
| 7:10 PM                         | 0                     | 0    | 0     | 0 | 0                     | 1    | 1     | 0 | 1                     | 0    | 0     | 0 | 0                     | 0    | 0     | 0 | 3     | 41            |
| 7:15 PM                         | 0                     | 0    | 0     | 0 | 1                     | 0    | 1     | 0 | 1                     | 0    | 0     | 0 | 0                     | 0    | 0     | 0 | 3     | 41            |
| 7:20 PM                         | 0                     | 0    | 0     | 0 | 0                     | 0    | 0     | 0 | 1                     | 0    | 0     | 0 | 0                     | 0    | 0     | 0 | 1     | 36            |
| 7:25 PM                         | 0                     | 1    | 0     | 0 | 0                     | 0    | 1     | 0 | 0                     | 0    | 0     | 0 | 0                     | 0    | 0     | 0 | 2     | 36            |
| 7:30 PM                         | 0                     | 1    | 0     | 0 | 0                     | 1    | 0     | 0 | 0                     | 0    | 0     | 0 | 0                     | 0    | 0     | 0 | 2     | 36            |
| 7:35 PM                         | 0                     | 0    | 0     | 0 | 0                     | 0    | 0     | 0 | 0                     | 0    | 0     | 0 | 0                     | 0    | 0     | 0 | 0     | 30            |
| 7:40 PM                         | 0                     | 0    | 0     | 0 | 0                     | 1    | 1     | 0 | 1                     | 0    | 0     | 0 | 0                     | 0    | 0     | 0 | 3     | 30            |
| 7:45 PM                         | 0                     | 1    | 0     | 0 | 1                     | 1    | 0     | 0 | 0                     | 0    | 0     | 0 | 0                     | 0    | 0     | 0 | 3     | 31            |
| 7:50 PM                         | 0                     | 0    | 0     | 0 | 1                     | 0    | 0     | 0 | 1                     | 0    | 0     | 0 | 0                     | 0    | 0     | 0 | 2     | 27            |
| 7:55 PM                         | 0                     | 0    | 0     | 0 | 0                     | 0    | 1     | 0 | 1                     | 0    | 0     | 0 | 0                     | 0    | 0     | 0 | 2     | 26            |
| 8:00 PM                         | 0                     | 0    | 0     | 0 | 0                     | 0    | 0     | 0 | 0                     | 0    | 0     | 0 | 0                     | 0    | 0     | 0 | 0     | 24            |
| 8:05 PM                         | 0                     | 0    | 0     | 0 | 2                     | 0    | 0     | 0 | 0                     | 0    | 0     | 0 | 0                     | 0    | 0     | 0 | 2     | 23            |
| 8:10 PM                         | 0                     | 0    | 0     | 0 | 0                     | 0    | 0     | 0 | 0                     | 0    | 0     | 0 | 0                     | 0    | 0     | 0 | 0     | 20            |
| 8:15 PM                         | 0                     | 0    | 0     | 0 | 0                     | 0    | 0     | 0 | 0                     | 0    | 0     | 0 | 0                     | 0    | 0     | 0 | 0     | 17            |
| 8:20 PM                         | 0                     | 0    | 0     | 0 | 0                     | 1    | 2     | 0 | 0                     | 0    | 0     | 0 | 0                     | 0    | 0     | 0 | 3     | 19            |
| 8:25 PM                         | 0                     | 1    | 0     | 0 | 1                     | 1    | 2     | 0 | 0                     | 0    | 0     | 0 | 0                     | 0    | 2     | 0 | 7     | 24            |
| 8:30 PM                         | 0                     | 0    | 0     | 0 | 0                     | 0    | 2     | 0 | 1                     | 0    | 0     | 0 | 0                     | 0    | 0     | 0 | 3     | 25            |
| 8:35 PM                         | 0                     | 0    | 0     | 0 | 0                     | 0    | 0     | 0 | 0                     | 0    | 0     | 0 | 0                     | 0    | 0     | 0 | 0     | 25            |
| 8:40 PM                         | 0                     | 0    | 0     | 0 | 0                     | 3    | 0     | 0 | 0                     | 0    | 0     | 0 | 0                     | 0    | 0     | 0 | 3     | 25            |
| 8:45 PM                         | 0                     | 0    | 0     | 0 | 0                     | 0    | 4     | 0 | 0                     | 0    | 0     | 0 | 0                     | 0    | 0     | 0 | 4     | 26            |
| 8:50 PM                         | 0                     | 0    | 0     | 0 | 2                     | 0    | 1     | 0 | 1                     | 0    | 0     | 0 | 0                     | 0    | 0     | 0 | 4     | 28            |
| 8:55 PM                         | 0                     | 0    | 0     | 0 | 0                     | 1    | 2     | 0 | 0                     | 0    | 0     | 0 | 0                     | 0    | 0     | 0 | 3     | 29            |
| 9:00 PM                         | 0                     | 1    | 0     | 0 | 1                     | 0    | 1     | 0 | 1                     | 0    | 0     | 0 | 0                     | 0    | 1     | 0 | 5     | 34            |
| 9:05 PM                         | 0                     | 0    | 0     | 0 | 0                     | 1    | 0     | 0 | 0                     | 0    | 0     | 0 | 0                     | 0    | 1     | 0 | 2     | 34            |
| 9:10 PM                         | 0                     | 0    | 0     | 0 | 0                     | 0    | 0     | 0 | 0                     | 0    | 0     | 0 | 0                     | 0    | 0     | 0 | 0     | 34            |
| 9:15 PM                         | 0                     | 1    | 0     | 0 | 1                     | 0    | 0     | 0 | 0                     | 0    | 0     | 0 | 0                     | 0    | 0     | 0 | 2     | 36            |
| 9:20 PM                         | 0                     | 0    | 0     | 0 | 0                     | 0    | 0     | 0 | 0                     | 0    | 0     | 0 | 0                     | 0    | 1     | 0 | 1     | 34            |
| 9:25 PM                         | 0                     | 0    | 0     | 0 | 0                     | 0    | 1     | 0 | 0                     | 0    | 0     | 0 | 0                     | 0    | 1     | 0 | 2     | 29            |
| 9:30 PM                         | 0                     | 0    | 0     | 0 | 0                     | 1    | 0     | 0 | 1                     | 0    | 0     | 0 | 0                     | 0    | 1     | 0 | 3     | 29            |
| 9:35 PM                         | 0                     | 0    | 0     | 0 | 0                     | 0    | 1     | 0 | 0                     | 0    | 0     | 0 | 0                     | 0    | 0     | 0 | 1     | 30            |
| 9:40 PM                         | 0                     | 0    | 0     | 0 | 0                     | 1    | 0     | 0 | 0                     | 0    | 0     | 0 | 0                     | 0    | 0     | 0 | 1     | 28            |
| 9:45 PM                         | 0                     | 1    | 0     | 0 | 0                     | 0    | 1     | 0 | 0                     | 0    | 0     | 0 | 0                     | 0    | 0     | 0 | 2     | 26            |
| 9:50 PM                         | 0                     | 0    | 0     | 0 | 1                     | 0    | 1     | 0 | 0                     | 0    | 0     | 0 | 0                     | 0    | 0     | 0 | 2     | 24            |
| 9:55 PM                         | 0                     | 0    | 0     | 0 | 1                     | 0    | 1     | 0 | 0                     | 0    | 0     | 0 | 0                     | 0    | 0     | 0 | 2     | 23            |
| Peak 15-Min Flowrates           | Northbound            |      |       |   | Southbound            |      |       |   | Eastbound             |      |       |   | Westbound             |      |       |   | Total |               |
|                                 | Left                  | Thru | Right | U | Left                  | Thru | Right | U | Left                  | Thru | Right | U | Left                  | Thru | Right | U |       |               |
| All Vehicles                    | 0                     | 8    | 0     | 0 | 8                     | 4    | 20    | 0 | 36                    | 0    | 0     | 0 | 0                     | 4    | 24    | 0 | 104   |               |
| Heavy Trucks                    | 0                     | 0    | 0     | 0 | 0                     | 0    | 0     | 0 | 0                     | 0    | 0     | 0 | 0                     | 0    | 0     | 0 | 0     |               |
| Buses                           |                       |      |       |   |                       |      |       |   |                       |      |       |   |                       |      |       |   |       |               |
| Pedestrians                     |                       | 4    |       |   |                       | 4    |       |   |                       | 8    |       |   |                       | 8    |       |   | 24    |               |
| Bicycles                        | 0                     | 0    | 0     |   | 0                     | 4    | 0     |   | 0                     | 0    | 4     |   | 0                     | 0    | 4     |   | 12    |               |
| Scoters                         |                       |      |       |   |                       |      |       |   |                       |      |       |   |                       |      |       |   |       |               |

Comments:

LOCATION: Castletree -- Crestview Dr  
 CITY/STATE: Las Flores, CA

QC JOB #: 16966454  
 DATE: Wed, Apr 16 2025

Peak-Hour: 3:05 PM -- 4:05 PM  
 Peak 15-Min: 3:05 PM -- 3:20 PM

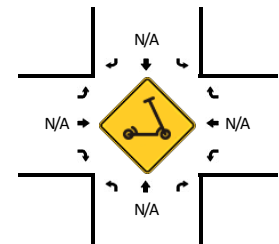
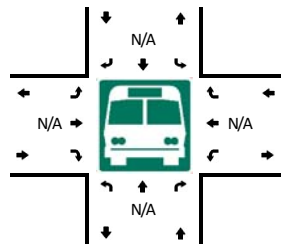
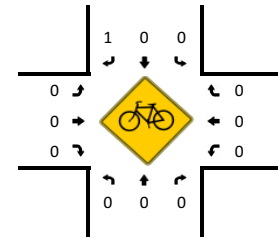
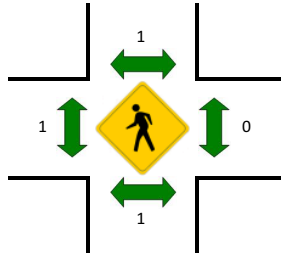
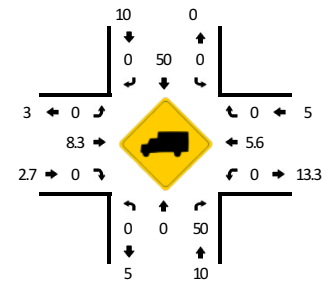
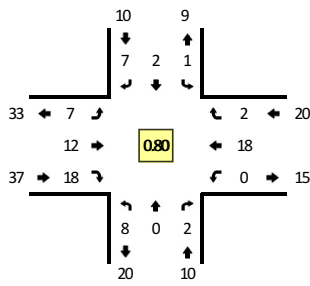

| 5-Min Count Period Beginning At | Castletree (Northbound) |      |       |   | Castletree (Southbound) |      |       |   | Crestview Dr (Eastbound) |      |       |   | Crestview Dr (Westbound) |      |       |   | Total | Hourly Totals |
|---------------------------------|-------------------------|------|-------|---|-------------------------|------|-------|---|--------------------------|------|-------|---|--------------------------|------|-------|---|-------|---------------|
|                                 | Left                    | Thru | Right | U | Left                    | Thru | Right | U | Left                     | Thru | Right | U | Left                     | Thru | Right | U |       |               |
| 6:00 AM                         | 0                       | 0    | 0     | 0 | 0                       | 0    | 0     | 0 | 0                        | 0    | 0     | 0 | 0                        | 0    | 0     | 0 | 0     | 0             |
| 6:05 AM                         | 0                       | 0    | 0     | 0 | 0                       | 0    | 0     | 0 | 0                        | 0    | 1     | 1 | 0                        | 0    | 1     | 0 | 0     | 0             |
| 6:10 AM                         | 0                       | 0    | 0     | 0 | 0                       | 0    | 0     | 0 | 0                        | 0    | 0     | 0 | 0                        | 0    | 0     | 0 | 0     | 0             |
| 6:15 AM                         | 0                       | 0    | 0     | 0 | 0                       | 0    | 0     | 0 | 0                        | 0    | 0     | 0 | 0                        | 0    | 0     | 0 | 0     | 0             |
| 6:20 AM                         | 1                       | 0    | 0     | 0 | 0                       | 0    | 0     | 0 | 0                        | 0    | 0     | 0 | 0                        | 0    | 0     | 0 | 0     | 1             |
| 6:25 AM                         | 0                       | 0    | 0     | 0 | 1                       | 0    | 0     | 0 | 0                        | 1    | 0     | 0 | 0                        | 0    | 0     | 1 | 0     | 3             |
| 6:30 AM                         | 0                       | 0    | 0     | 0 | 0                       | 0    | 1     | 0 | 0                        | 0    | 0     | 0 | 0                        | 0    | 0     | 0 | 0     | 1             |
| 6:35 AM                         | 1                       | 0    | 0     | 0 | 0                       | 0    | 0     | 0 | 0                        | 0    | 0     | 0 | 0                        | 0    | 0     | 0 | 0     | 1             |
| 6:40 AM                         | 0                       | 0    | 0     | 0 | 0                       | 0    | 1     | 0 | 0                        | 0    | 1     | 0 | 0                        | 0    | 0     | 0 | 0     | 2             |
| 6:45 AM                         | 0                       | 0    | 0     | 0 | 1                       | 0    | 0     | 0 | 0                        | 0    | 0     | 0 | 0                        | 0    | 0     | 0 | 0     | 1             |
| 6:50 AM                         | 0                       | 0    | 0     | 0 | 0                       | 0    | 0     | 0 | 0                        | 0    | 0     | 0 | 0                        | 0    | 0     | 0 | 0     | 0             |
| 6:55 AM                         | 2                       | 0    | 0     | 0 | 0                       | 0    | 1     | 0 | 0                        | 1    | 0     | 2 | 0                        | 0    | 1     | 0 | 0     | 7             |
| 7:00 AM                         | 0                       | 0    | 0     | 0 | 0                       | 0    | 0     | 0 | 0                        | 0    | 0     | 0 | 0                        | 2    | 0     | 0 | 0     | 2             |
| 7:05 AM                         | 0                       | 0    | 0     | 0 | 0                       | 0    | 0     | 0 | 0                        | 0    | 1     | 1 | 0                        | 2    | 0     | 0 | 0     | 4             |
| 7:10 AM                         | 3                       | 0    | 0     | 0 | 0                       | 0    | 0     | 0 | 0                        | 0    | 0     | 0 | 0                        | 1    | 0     | 0 | 0     | 4             |
| 7:15 AM                         | 0                       | 0    | 0     | 0 | 0                       | 0    | 0     | 0 | 0                        | 0    | 0     | 1 | 0                        | 0    | 0     | 0 | 0     | 1             |
| 7:20 AM                         | 0                       | 0    | 0     | 0 | 0                       | 0    | 0     | 0 | 0                        | 0    | 0     | 0 | 0                        | 0    | 0     | 0 | 0     | 0             |
| 7:25 AM                         | 3                       | 0    | 0     | 0 | 1                       | 0    | 1     | 0 | 0                        | 0    | 0     | 0 | 0                        | 0    | 0     | 0 | 0     | 5             |
| 7:30 AM                         | 2                       | 0    | 0     | 0 | 0                       | 0    | 0     | 0 | 0                        | 2    | 0     | 0 | 0                        | 1    | 0     | 0 | 0     | 5             |
| 7:35 AM                         | 2                       | 0    | 0     | 0 | 0                       | 0    | 1     | 0 | 0                        | 1    | 0     | 1 | 0                        | 0    | 0     | 0 | 0     | 5             |
| 7:40 AM                         | 1                       | 0    | 1     | 0 | 0                       | 0    | 1     | 0 | 0                        | 0    | 2     | 0 | 0                        | 1    | 0     | 0 | 0     | 6             |
| 7:45 AM                         | 2                       | 0    | 0     | 0 | 0                       | 0    | 0     | 0 | 0                        | 0    | 0     | 0 | 0                        | 0    | 0     | 0 | 0     | 2             |
| 7:50 AM                         | 1                       | 0    | 0     | 0 | 0                       | 0    | 2     | 0 | 0                        | 0    | 0     | 1 | 0                        | 1    | 1     | 0 | 0     | 6             |
| 7:55 AM                         | 0                       | 0    | 0     | 0 | 0                       | 1    | 0     | 0 | 0                        | 0    | 0     | 1 | 1                        | 0    | 0     | 0 | 0     | 3             |
| 8:00 AM                         | 2                       | 0    | 0     | 0 | 0                       | 0    | 3     | 0 | 0                        | 1    | 0     | 0 | 0                        | 2    | 0     | 0 | 0     | 8             |
| 8:05 AM                         | 1                       | 0    | 0     | 0 | 0                       | 0    | 0     | 0 | 0                        | 1    | 1     | 0 | 0                        | 2    | 0     | 0 | 0     | 5             |
| 8:10 AM                         | 3                       | 0    | 0     | 0 | 1                       | 0    | 0     | 0 | 0                        | 0    | 0     | 0 | 0                        | 0    | 0     | 0 | 0     | 4             |
| 8:15 AM                         | 1                       | 0    | 0     | 0 | 0                       | 0    | 1     | 0 | 0                        | 0    | 2     | 0 | 0                        | 1    | 0     | 0 | 0     | 5             |
| 8:20 AM                         | 1                       | 0    | 0     | 0 | 0                       | 0    | 1     | 0 | 0                        | 1    | 1     | 0 | 0                        | 1    | 0     | 0 | 0     | 5             |
| 8:25 AM                         | 2                       | 0    | 0     | 0 | 0                       | 0    | 1     | 0 | 0                        | 1    | 1     | 2 | 0                        | 0    | 0     | 0 | 0     | 7             |
| 8:30 AM                         | 0                       | 0    | 0     | 0 | 0                       | 0    | 0     | 0 | 0                        | 0    | 1     | 0 | 0                        | 0    | 0     | 0 | 0     | 1             |
| 8:35 AM                         | 1                       | 0    | 0     | 0 | 0                       | 0    | 0     | 1 | 0                        | 1    | 0     | 1 | 0                        | 0    | 0     | 0 | 0     | 4             |
| 8:40 AM                         | 2                       | 0    | 0     | 0 | 0                       | 0    | 0     | 0 | 0                        | 0    | 0     | 0 | 0                        | 1    | 0     | 0 | 0     | 3             |
| 8:45 AM                         | 0                       | 0    | 0     | 0 | 0                       | 0    | 1     | 0 | 0                        | 0    | 1     | 0 | 0                        | 0    | 0     | 0 | 0     | 2             |
| 8:50 AM                         | 0                       | 0    | 0     | 0 | 0                       | 0    | 0     | 0 | 0                        | 0    | 0     | 0 | 0                        | 2    | 0     | 0 | 0     | 2             |
| 8:55 AM                         | 1                       | 0    | 0     | 0 | 0                       | 0    | 0     | 0 | 0                        | 0    | 1     | 0 | 0                        | 0    | 0     | 0 | 0     | 2             |
| 9:00 AM                         | 0                       | 0    | 0     | 0 | 0                       | 0    | 0     | 0 | 0                        | 0    | 2     | 0 | 0                        | 0    | 1     | 0 | 0     | 3             |
| 9:05 AM                         | 0                       | 0    | 0     | 0 | 0                       | 0    | 0     | 0 | 0                        | 0    | 0     | 0 | 0                        | 0    | 0     | 0 | 0     | 0             |

**Attachment B**

| 5-Min Count Period Beginning At | Castletree (Northbound) |      |       |   | Castletree (Southbound) |      |       |   | Crestview Dr (Eastbound) |      |       |   | Crestview Dr (Westbound) |      |       |   | Total | Hourly Totals |
|---------------------------------|-------------------------|------|-------|---|-------------------------|------|-------|---|--------------------------|------|-------|---|--------------------------|------|-------|---|-------|---------------|
|                                 | Left                    | Thru | Right | U | Left                    | Thru | Right | U | Left                     | Thru | Right | U | Left                     | Thru | Right | U |       |               |
| 9:10 AM                         | 2                       | 0    | 0     | 0 | 0                       | 0    | 0     | 0 | 0                        | 0    | 1     | 0 | 1                        | 0    | 0     | 0 | 4     | 38            |
| 9:15 AM                         | 1                       | 0    | 0     | 0 | 0                       | 0    | 0     | 0 | 0                        | 0    | 0     | 0 | 0                        | 1    | 0     | 0 | 2     | 35            |
| 9:20 AM                         | 1                       | 0    | 0     | 0 | 0                       | 0    | 0     | 0 | 0                        | 2    | 0     | 1 | 0                        | 0    | 1     | 0 | 5     | 35            |
| 9:25 AM                         | 0                       | 0    | 0     | 0 | 0                       | 0    | 0     | 0 | 0                        | 0    | 0     | 2 | 0                        | 0    | 1     | 0 | 3     | 31            |
| 9:30 AM                         | 0                       | 0    | 0     | 0 | 0                       | 0    | 1     | 0 | 0                        | 0    | 2     | 1 | 0                        | 0    | 1     | 0 | 5     | 35            |
| 9:35 AM                         | 0                       | 0    | 0     | 0 | 0                       | 0    | 0     | 0 | 0                        | 1    | 0     | 0 | 0                        | 0    | 1     | 0 | 2     | 33            |
| 9:40 AM                         | 1                       | 0    | 0     | 0 | 0                       | 0    | 0     | 0 | 0                        | 0    | 0     | 0 | 0                        | 0    | 0     | 0 | 1     | 31            |
| 9:45 AM                         | 1                       | 0    | 0     | 0 | 0                       | 0    | 1     | 0 | 0                        | 0    | 0     | 1 | 0                        | 0    | 1     | 0 | 4     | 33            |
| 9:50 AM                         | 0                       | 0    | 0     | 0 | 0                       | 0    | 1     | 0 | 0                        | 0    | 0     | 0 | 0                        | 0    | 1     | 0 | 2     | 33            |
| 9:55 AM                         | 1                       | 0    | 0     | 0 | 0                       | 0    | 1     | 0 | 0                        | 0    | 0     | 0 | 0                        | 2    | 0     | 0 | 4     | 35            |
| 10:00 AM                        | 1                       | 0    | 0     | 0 | 0                       | 0    | 0     | 0 | 0                        | 0    | 0     | 0 | 0                        | 1    | 0     | 0 | 2     | 34            |
| 10:05 AM                        | 1                       | 0    | 0     | 0 | 0                       | 0    | 0     | 0 | 0                        | 0    | 0     | 0 | 0                        | 1    | 0     | 0 | 2     | 36            |
| 10:10 AM                        | 1                       | 0    | 0     | 0 | 0                       | 0    | 0     | 0 | 0                        | 0    | 1     | 0 | 0                        | 0    | 1     | 0 | 3     | 35            |
| 10:15 AM                        | 1                       | 0    | 0     | 0 | 0                       | 0    | 1     | 0 | 0                        | 0    | 0     | 0 | 0                        | 0    | 1     | 0 | 3     | 36            |
| 10:20 AM                        | 0                       | 0    | 0     | 0 | 1                       | 0    | 0     | 0 | 0                        | 0    | 0     | 0 | 0                        | 1    | 0     | 0 | 2     | 33            |
| 10:25 AM                        | 0                       | 0    | 0     | 0 | 0                       | 0    | 1     | 0 | 0                        | 1    | 0     | 0 | 0                        | 0    | 1     | 0 | 3     | 33            |
| 10:30 AM                        | 1                       | 0    | 0     | 1 | 0                       | 1    | 0     | 0 | 0                        | 0    | 0     | 0 | 0                        | 0    | 0     | 0 | 3     | 31            |
| 10:35 AM                        | 1                       | 0    | 1     | 0 | 0                       | 0    | 0     | 0 | 0                        | 2    | 0     | 0 | 0                        | 0    | 1     | 0 | 5     | 34            |
| 10:40 AM                        | 0                       | 0    | 0     | 0 | 0                       | 0    | 0     | 0 | 0                        | 0    | 0     | 0 | 0                        | 2    | 0     | 0 | 2     | 35            |
| 10:45 AM                        | 0                       | 0    | 0     | 0 | 0                       | 0    | 0     | 0 | 0                        | 2    | 0     | 0 | 0                        | 0    | 1     | 0 | 4     | 35            |
| 10:50 AM                        | 1                       | 0    | 0     | 0 | 0                       | 1    | 1     | 0 | 0                        | 2    | 1     | 0 | 0                        | 0    | 0     | 0 | 6     | 39            |
| 10:55 AM                        | 0                       | 0    | 0     | 0 | 0                       | 0    | 0     | 0 | 0                        | 0    | 0     | 0 | 0                        | 0    | 0     | 0 | 0     | 35            |
| 11:00 AM                        | 1                       | 0    | 0     | 0 | 0                       | 0    | 0     | 0 | 0                        | 0    | 0     | 1 | 0                        | 0    | 1     | 0 | 3     | 36            |
| 11:05 AM                        | 0                       | 0    | 0     | 0 | 0                       | 0    | 1     | 0 | 0                        | 1    | 0     | 0 | 0                        | 0    | 0     | 0 | 2     | 36            |
| 11:10 AM                        | 1                       | 0    | 0     | 0 | 0                       | 0    | 0     | 0 | 0                        | 0    | 0     | 0 | 0                        | 1    | 0     | 0 | 2     | 35            |
| 11:15 AM                        | 2                       | 0    | 0     | 0 | 0                       | 1    | 0     | 0 | 0                        | 0    | 1     | 2 | 0                        | 0    | 1     | 1 | 8     | 40            |
| 11:20 AM                        | 0                       | 1    | 0     | 0 | 0                       | 0    | 1     | 0 | 0                        | 0    | 1     | 1 | 0                        | 0    | 1     | 1 | 6     | 44            |
| 11:25 AM                        | 1                       | 0    | 0     | 0 | 0                       | 0    | 0     | 0 | 0                        | 1    | 0     | 0 | 0                        | 0    | 0     | 0 | 2     | 43            |
| 11:30 AM                        | 0                       | 0    | 0     | 0 | 0                       | 0    | 0     | 0 | 0                        | 0    | 0     | 2 | 0                        | 0    | 0     | 0 | 2     | 42            |
| 11:35 AM                        | 1                       | 0    | 0     | 0 | 0                       | 0    | 0     | 0 | 0                        | 0    | 0     | 0 | 0                        | 0    | 0     | 0 | 1     | 38            |
| 11:40 AM                        | 2                       | 0    | 0     | 0 | 0                       | 0    | 0     | 0 | 0                        | 2    | 0     | 0 | 0                        | 0    | 0     | 0 | 4     | 40            |
| 11:45 AM                        | 0                       | 0    | 1     | 0 | 0                       | 1    | 0     | 0 | 0                        | 0    | 0     | 1 | 0                        | 0    | 0     | 0 | 3     | 39            |
| 11:50 AM                        | 1                       | 1    | 0     | 0 | 1                       | 0    | 0     | 0 | 0                        | 0    | 1     | 0 | 0                        | 1    | 0     | 0 | 5     | 38            |
| 11:55 AM                        | 2                       | 0    | 0     | 0 | 0                       | 0    | 0     | 0 | 0                        | 0    | 1     | 0 | 0                        | 0    | 1     | 2 | 6     | 44            |
| 12:00 PM                        | 0                       | 0    | 0     | 0 | 0                       | 0    | 4     | 0 | 0                        | 0    | 2     | 0 | 0                        | 0    | 1     | 0 | 7     | 48            |
| 12:05 PM                        | 0                       | 0    | 0     | 0 | 0                       | 0    | 0     | 0 | 0                        | 0    | 0     | 0 | 0                        | 0    | 1     | 0 | 1     | 47            |
| 12:10 PM                        | 0                       | 0    | 0     | 0 | 0                       | 0    | 1     | 0 | 0                        | 0    | 0     | 1 | 0                        | 0    | 0     | 0 | 2     | 47            |
| 12:15 PM                        | 1                       | 0    | 0     | 0 | 0                       | 0    | 0     | 0 | 0                        | 1    | 1     | 0 | 0                        | 0    | 0     | 0 | 3     | 42            |
| 12:20 PM                        | 2                       | 0    | 0     | 0 | 0                       | 0    | 0     | 0 | 0                        | 1    | 1     | 0 | 0                        | 0    | 1     | 1 | 6     | 42            |
| 12:25 PM                        | 0                       | 0    | 0     | 0 | 0                       | 0    | 0     | 0 | 0                        | 0    | 1     | 0 | 0                        | 0    | 1     | 0 | 2     | 42            |
| 12:30 PM                        | 1                       | 0    | 0     | 0 | 0                       | 0    | 1     | 0 | 0                        | 0    | 0     | 1 | 0                        | 0    | 2     | 0 | 5     | 45            |
| 12:35 PM                        | 1                       | 0    | 0     | 0 | 0                       | 0    | 0     | 0 | 0                        | 0    | 0     | 0 | 0                        | 0    | 1     | 0 | 2     | 46            |
| 12:40 PM                        | 0                       | 0    | 0     | 0 | 0                       | 0    | 0     | 0 | 0                        | 0    | 1     | 1 | 0                        | 0    | 0     | 0 | 2     | 44            |
| 12:45 PM                        | 1                       | 0    | 0     | 0 | 0                       | 0    | 0     | 0 | 0                        | 0    | 1     | 0 | 0                        | 0    | 1     | 0 | 3     | 44            |
| 12:50 PM                        | 0                       | 0    | 0     | 0 | 0                       | 0    | 1     | 0 | 0                        | 0    | 0     | 0 | 0                        | 0    | 0     | 0 | 1     | 40            |
| 12:55 PM                        | 0                       | 0    | 0     | 0 | 0                       | 0    | 0     | 0 | 0                        | 0    | 0     | 1 | 0                        | 0    | 0     | 0 | 1     | 35            |
| 1:00 PM                         | 0                       | 0    | 0     | 0 | 0                       | 0    | 1     | 0 | 0                        | 2    | 3     | 1 | 0                        | 0    | 1     | 0 | 8     | 36            |
| 1:05 PM                         | 0                       | 0    | 0     | 0 | 0                       | 0    | 0     | 0 | 0                        | 0    | 0     | 2 | 0                        | 0    | 0     | 0 | 2     | 37            |
| 1:10 PM                         | 1                       | 0    | 0     | 0 | 0                       | 0    | 0     | 0 | 0                        | 2    | 0     | 0 | 0                        | 0    | 1     | 0 | 4     | 39            |
| 1:15 PM                         | 1                       | 0    | 0     | 0 | 0                       | 0    | 0     | 0 | 0                        | 0    | 0     | 0 | 0                        | 0    | 0     | 0 | 1     | 37            |
| 1:20 PM                         | 1                       | 0    | 0     | 0 | 0                       | 0    | 0     | 0 | 0                        | 0    | 2     | 0 | 0                        | 0    | 0     | 0 | 3     | 34            |
| 1:25 PM                         | 0                       | 0    | 0     | 0 | 0                       | 0    | 1     | 0 | 0                        | 0    | 0     | 1 | 0                        | 0    | 3     | 0 | 5     | 37            |
| 1:30 PM                         | 1                       | 0    | 0     | 0 | 0                       | 0    | 0     | 0 | 0                        | 0    | 0     | 2 | 0                        | 1    | 1     | 0 | 5     | 37            |
| 1:35 PM                         | 0                       | 0    | 0     | 0 | 0                       | 0    | 0     | 0 | 0                        | 0    | 1     | 3 | 0                        | 0    | 0     | 0 | 4     | 39            |
| 1:40 PM                         | 2                       | 0    | 0     | 0 | 0                       | 0    | 0     | 0 | 0                        | 0    | 2     | 1 | 0                        | 0    | 0     | 0 | 5     | 42            |
| 1:45 PM                         | 3                       | 1    | 0     | 0 | 0                       | 0    | 0     | 0 | 0                        | 0    | 0     | 0 | 0                        | 0    | 0     | 0 | 4     | 43            |
| 1:50 PM                         | 0                       | 0    | 0     | 0 | 0                       | 0    | 0     | 0 | 0                        | 0    | 0     | 0 | 0                        | 0    | 1     | 0 | 1     | 43            |
| 1:55 PM                         | 1                       | 0    | 0     | 0 | 0                       | 0    | 0     | 0 | 0                        | 2    | 0     | 1 | 0                        | 0    | 0     | 0 | 4     | 46            |
| 2:00 PM                         | 1                       | 0    | 1     | 0 | 0                       | 0    | 2     | 0 | 0                        | 0    | 1     | 5 | 0                        | 0    | 1     | 0 | 11    | 49            |
| 2:05 PM                         | 2                       | 0    | 0     | 0 | 0                       | 0    | 0     | 0 | 0                        | 0    | 0     | 0 | 0                        | 0    | 0     | 1 | 3     | 50            |
| 2:10 PM                         | 1                       | 0    | 0     | 0 | 0                       | 0    | 0     | 0 | 0                        | 0    | 0     | 1 | 0                        | 0    | 1     | 0 | 3     | 49            |
| 2:15 PM                         | 0                       | 1    | 0     | 0 | 0                       | 0    | 1     | 0 | 0                        | 0    | 0     | 2 | 0                        | 0    | 0     | 0 | 4     | 52            |
| 2:20 PM                         | 0                       | 0    | 0     | 0 | 0                       | 0    | 0     | 0 | 0                        | 1    | 0     | 2 | 0                        | 0    | 0     | 0 | 3     | 52            |
| 2:25 PM                         | 2                       | 0    | 0     | 0 | 0                       | 0    | 0     | 0 | 0                        | 0    | 2     | 0 | 0                        | 0    | 0     | 0 | 4     | 51            |
| 2:30 PM                         | 1                       | 0    | 0     | 0 | 0                       | 0    | 0     | 0 | 0                        | 2    | 1     | 0 | 0                        | 0    | 0     | 0 | 4     | 50            |
| 2:35 PM                         | 1                       | 0    | 0     | 0 | 0                       | 0    | 0     | 0 | 0                        | 0    | 4     | 2 | 0                        | 0    | 2     | 0 | 9     | 55            |
| 2:40 PM                         | 0                       | 0    | 0     | 0 | 0                       | 0    | 0     | 0 | 0                        | 1    | 0     | 0 | 0                        | 1    | 0     | 0 | 2     | 52            |
| 2:45 PM                         | 1                       | 1    | 0     | 0 | 0                       | 0    | 0     | 0 | 0                        | 1    | 0     | 0 | 0                        | 0    | 0     | 0 | 3     | 51            |
| 2:50 PM                         | 1                       | 0    | 0     | 0 | 0                       | 0    | 0     | 0 | 0                        | 1    | 1     | 0 | 0                        | 0    | 1     | 0 | 4     | 54            |
| 2:55 PM                         | 0                       | 0    | 0     | 0 | 0                       | 0    | 0     | 0 | 0                        | 0    | 1     | 2 | 0                        | 0    | 1     | 0 | 4     | 54            |
| 3:00 PM                         | 0                       | 1    | 0     | 0 | 0                       | 0    | 1     | 0 | 0                        | 0    | 0     | 1 | 0                        | 0    | 1     | 0 | 4     | 47            |
| 3:05 PM                         | 0                       | 0    | 0     | 0 | 0                       | 1    | 1     | 0 | 0                        | 1    | 0     | 2 | 0                        | 0    | 0     | 0 | 5     | 49            |
| 3:10 PM                         | 1                       | 0    | 1     | 0 | 0                       | 1    | 0     | 0 | 0                        | 2    | 5     | 0 | 0                        | 0    | 0     | 0 | 10    | 56            |
| 3:15 PM                         | 1                       | 0    | 0     | 0 | 0                       | 0    | 1     | 0 | 0                        | 1    | 1     | 4 | 0                        | 0    | 1     | 0 | 9     | 61            |
| 3:20 PM                         | 0                       | 0    | 0     | 0 | 0                       | 0    | 0     | 0 | 0                        | 1    | 1     | 2 | 0                        | 0    | 1     | 0 | 5     | 63            |
| 3:25 PM                         | 0                       | 0    | 1     | 0 | 1                       | 0    | 0     | 0 | 0                        | 0    | 0     | 2 | 0                        | 0    | 1     | 1 | 6     | 65            |
| 3:30 PM                         | 2                       | 0    | 0     | 0 | 0                       | 0    | 0     | 0 | 0                        | 0    | 2     | 0 | 0                        | 0    | 0     | 0 | 4     | 65            |
| 3:35 PM                         | 1                       | 0    | 0     | 0 | 0                       | 0    | 1     | 0 | 0                        | 0    | 0     | 0 | 0                        | 0    | 1     | 0 | 3     | 59            |
| 3:40 PM                         | 2                       | 0    | 0     | 0 | 0                       | 0    | 0     | 0 | 0                        | 1    | 1     | 0 | 0                        | 0    | 4     | 0 | 8     | 65            |
| 3:45 PM                         | 1                       | 0    | 0     | 0 | 0                       | 0    | 3     | 0 | 0                        | 0    | 1     | 2 | 0                        | 0    | 1     | 1 | 9     | 71            |
| 3:50 PM                         | 0                       | 0    | 0     | 0 | 0                       | 0    | 0     | 0 | 0                        | 0    | 0     | 0 | 0                        | 0    | 3     | 0 | 3     | 70            |
| 3:55 PM                         | 0                       | 0    | 0     | 0 | 0                       | 0    | 0     | 0 | 0                        | 1    | 0     | 3 | 0                        | 0    | 5     | 0 | 9     | 75            |
| 4:00 PM                         | 0                       | 0    | 0     | 0 | 0                       | 0    | 1     | 0 | 0                        | 0    | 1     | 3 | 0                        | 0    | 1     | 0 | 6     | 77            |
| 4:05 PM                         | 2                       | 0    | 0     | 0 | 0                       | 1    | 1     | 0 | 0                        | 1    | 0     | 0 | 0                        | 0    | 0     | 0 | 5     | 77            |
| 4:10 PM                         | 0                       | 0    | 1     | 0 | 0                       | 0    | 1     | 0 | 0                        | 0    | 0     | 0 | 0                        | 0    | 0     | 0 | 2     | 69            |
| 4:15 PM                         | 0                       | 0    | 0     | 0 | 0                       | 1    | 0     | 0 | 0                        | 0    | 0     | 4 | 0                        | 0    | 1     | 0 | 6     | 66            |
| 4:20 PM                         | 1                       | 0    | 0     | 0 | 0                       | 0    | 1     | 0 | 0                        | 3    | 2     | 0 | 0                        | 0    | 0     | 0 | 7     | 68            |
| 4:25 PM                         | 3                       | 0    | 0     | 0 | 1                       | 0    | 1     | 0 | 0                        | 1    | 2     | 1 | 0                        | 0    | 3     | 0 | 12    | 74            |

**Attachment B**

| 5-Min Count Period Beginning At | Castletree (Northbound) |      |       |   | Castletree (Southbound) |      |       |   | Crestview Dr (Eastbound) |      |       |   | Crestview Dr (Westbound) |      |       |   | Total | Hourly Totals |
|---------------------------------|-------------------------|------|-------|---|-------------------------|------|-------|---|--------------------------|------|-------|---|--------------------------|------|-------|---|-------|---------------|
|                                 | Left                    | Thru | Right | U | Left                    | Thru | Right | U | Left                     | Thru | Right | U | Left                     | Thru | Right | U |       |               |
| 4:30 PM                         | 2                       | 0    | 0     | 0 | 0                       | 0    | 0     | 0 | 1                        | 1    | 0     | 0 | 0                        | 3    | 0     | 0 | 7     | 77            |
| 4:35 PM                         | 0                       | 0    | 0     | 0 | 0                       | 0    | 0     | 0 | 0                        | 1    | 2     | 0 | 0                        | 0    | 0     | 0 | 3     | 77            |
| 4:40 PM                         | 0                       | 0    | 0     | 0 | 0                       | 0    | 0     | 0 | 0                        | 2    | 0     | 0 | 0                        | 3    | 1     | 0 | 6     | 75            |
| 4:45 PM                         | 0                       | 0    | 0     | 0 | 0                       | 0    | 1     | 0 | 0                        | 2    | 0     | 0 | 0                        | 1    | 0     | 0 | 4     | 70            |
| 4:50 PM                         | 0                       | 0    | 0     | 0 | 0                       | 0    | 0     | 0 | 0                        | 1    | 2     | 0 | 0                        | 1    | 0     | 0 | 4     | 71            |
| 4:55 PM                         | 1                       | 0    | 0     | 0 | 0                       | 0    | 0     | 0 | 0                        | 0    | 1     | 0 | 0                        | 0    | 0     | 0 | 2     | 64            |
| 5:00 PM                         | 0                       | 0    | 0     | 0 | 0                       | 0    | 0     | 0 | 0                        | 1    | 0     | 0 | 0                        | 1    | 0     | 0 | 2     | 60            |
| 5:05 PM                         | 3                       | 0    | 0     | 0 | 0                       | 0    | 0     | 0 | 1                        | 1    | 2     | 0 | 0                        | 0    | 0     | 0 | 7     | 62            |
| 5:10 PM                         | 0                       | 0    | 0     | 0 | 0                       | 0    | 0     | 0 | 1                        | 1    | 1     | 0 | 0                        | 0    | 0     | 0 | 3     | 63            |
| 5:15 PM                         | 2                       | 0    | 0     | 0 | 0                       | 0    | 1     | 0 | 1                        | 3    | 0     | 0 | 0                        | 1    | 0     | 0 | 8     | 65            |
| 5:20 PM                         | 2                       | 0    | 0     | 0 | 0                       | 0    | 1     | 0 | 1                        | 1    | 0     | 0 | 0                        | 0    | 0     | 0 | 5     | 63            |
| 5:25 PM                         | 1                       | 0    | 0     | 0 | 0                       | 0    | 0     | 0 | 2                        | 1    | 0     | 0 | 0                        | 0    | 1     | 0 | 5     | 56            |
| 5:30 PM                         | 0                       | 0    | 0     | 0 | 0                       | 0    | 0     | 0 | 1                        | 2    | 0     | 0 | 0                        | 1    | 0     | 0 | 4     | 53            |
| 5:35 PM                         | 1                       | 0    | 0     | 0 | 0                       | 0    | 0     | 0 | 0                        | 1    | 0     | 0 | 0                        | 1    | 0     | 0 | 3     | 53            |
| 5:40 PM                         | 0                       | 0    | 0     | 0 | 0                       | 0    | 0     | 0 | 0                        | 0    | 1     | 0 | 0                        | 1    | 0     | 0 | 2     | 49            |
| 5:45 PM                         | 1                       | 0    | 0     | 0 | 0                       | 0    | 0     | 0 | 2                        | 0    | 0     | 0 | 0                        | 1    | 1     | 0 | 5     | 50            |
| 5:50 PM                         | 0                       | 0    | 0     | 0 | 0                       | 0    | 0     | 0 | 0                        | 1    | 2     | 0 | 0                        | 0    | 0     | 0 | 3     | 49            |
| 5:55 PM                         | 0                       | 0    | 0     | 0 | 0                       | 0    | 1     | 0 | 1                        | 0    | 1     | 0 | 0                        | 0    | 0     | 0 | 3     | 50            |
| 6:00 PM                         | 1                       | 0    | 0     | 0 | 0                       | 0    | 0     | 0 | 0                        | 0    | 2     | 0 | 0                        | 1    | 0     | 0 | 4     | 52            |
| 6:05 PM                         | 0                       | 0    | 0     | 0 | 0                       | 0    | 2     | 0 | 1                        | 1    | 0     | 0 | 0                        | 1    | 0     | 0 | 5     | 50            |
| 6:10 PM                         | 0                       | 0    | 0     | 0 | 0                       | 0    | 0     | 0 | 1                        | 0    | 0     | 0 | 0                        | 0    | 0     | 0 | 1     | 48            |
| 6:15 PM                         | 1                       | 0    | 0     | 0 | 0                       | 1    | 0     | 0 | 1                        | 1    | 3     | 0 | 0                        | 0    | 0     | 0 | 7     | 47            |
| 6:20 PM                         | 1                       | 0    | 0     | 0 | 0                       | 0    | 0     | 0 | 2                        | 2    | 1     | 0 | 0                        | 1    | 0     | 0 | 7     | 49            |
| 6:25 PM                         | 0                       | 0    | 0     | 0 | 0                       | 0    | 0     | 0 | 0                        | 1    | 1     | 0 | 0                        | 0    | 0     | 0 | 2     | 46            |
| 6:30 PM                         | 0                       | 0    | 0     | 0 | 0                       | 0    | 0     | 0 | 0                        | 1    | 3     | 0 | 0                        | 1    | 0     | 0 | 5     | 47            |
| 6:35 PM                         | 2                       | 1    | 0     | 0 | 0                       | 0    | 0     | 0 | 0                        | 1    | 2     | 0 | 0                        | 1    | 0     | 0 | 7     | 51            |
| 6:40 PM                         | 0                       | 0    | 0     | 0 | 0                       | 0    | 2     | 0 | 2                        | 2    | 3     | 0 | 0                        | 2    | 0     | 0 | 11    | 60            |
| 6:45 PM                         | 2                       | 0    | 0     | 0 | 0                       | 0    | 1     | 0 | 0                        | 1    | 0     | 0 | 0                        | 0    | 1     | 0 | 5     | 60            |
| 6:50 PM                         | 1                       | 0    | 0     | 0 | 0                       | 0    | 0     | 0 | 1                        | 1    | 0     | 0 | 0                        | 0    | 0     | 0 | 3     | 60            |
| 6:55 PM                         | 0                       | 0    | 0     | 0 | 0                       | 0    | 1     | 0 | 2                        | 0    | 1     | 0 | 0                        | 0    | 0     | 0 | 4     | 61            |
| 7:00 PM                         | 0                       | 0    | 0     | 0 | 0                       | 0    | 1     | 0 | 0                        | 1    | 0     | 0 | 0                        | 1    | 0     | 0 | 3     | 60            |
| 7:05 PM                         | 0                       | 0    | 0     | 0 | 0                       | 0    | 1     | 0 | 1                        | 1    | 1     | 0 | 0                        | 0    | 0     | 0 | 4     | 59            |
| 7:10 PM                         | 0                       | 0    | 0     | 0 | 0                       | 0    | 0     | 0 | 0                        | 0    | 0     | 0 | 0                        | 0    | 0     | 0 | 0     | 58            |
| 7:15 PM                         | 0                       | 0    | 0     | 0 | 0                       | 0    | 0     | 0 | 1                        | 0    | 1     | 0 | 0                        | 1    | 0     | 0 | 3     | 54            |
| 7:20 PM                         | 0                       | 0    | 0     | 0 | 0                       | 0    | 0     | 0 | 1                        | 1    | 0     | 0 | 0                        | 1    | 0     | 0 | 3     | 50            |
| 7:25 PM                         | 1                       | 0    | 0     | 0 | 0                       | 0    | 1     | 0 | 0                        | 0    | 2     | 0 | 0                        | 1    | 0     | 0 | 5     | 53            |
| 7:30 PM                         | 0                       | 0    | 0     | 0 | 0                       | 0    | 0     | 0 | 1                        | 0    | 0     | 0 | 0                        | 1    | 0     | 0 | 2     | 50            |
| 7:35 PM                         | 0                       | 0    | 0     | 0 | 0                       | 0    | 0     | 0 | 1                        | 1    | 0     | 0 | 0                        | 1    | 0     | 0 | 3     | 46            |
| 7:40 PM                         | 0                       | 0    | 0     | 0 | 0                       | 0    | 0     | 0 | 0                        | 0    | 0     | 0 | 0                        | 1    | 0     | 0 | 1     | 36            |
| 7:45 PM                         | 0                       | 0    | 0     | 0 | 0                       | 0    | 0     | 0 | 1                        | 0    | 1     | 0 | 0                        | 0    | 0     | 0 | 2     | 33            |
| 7:50 PM                         | 0                       | 0    | 0     | 0 | 0                       | 0    | 0     | 0 | 0                        | 0    | 0     | 0 | 0                        | 1    | 0     | 0 | 1     | 31            |
| 7:55 PM                         | 0                       | 0    | 0     | 0 | 0                       | 0    | 1     | 0 | 1                        | 0    | 0     | 0 | 0                        | 0    | 0     | 0 | 2     | 29            |
| 8:00 PM                         | 0                       | 0    | 0     | 0 | 0                       | 0    | 0     | 0 | 1                        | 0    | 0     | 0 | 0                        | 0    | 0     | 0 | 1     | 27            |
| 8:05 PM                         | 0                       | 0    | 0     | 0 | 0                       | 0    | 0     | 0 | 0                        | 0    | 1     | 0 | 0                        | 0    | 0     | 0 | 1     | 24            |
| 8:10 PM                         | 0                       | 0    | 0     | 0 | 0                       | 0    | 0     | 0 | 0                        | 0    | 1     | 0 | 0                        | 0    | 0     | 0 | 1     | 25            |
| 8:15 PM                         | 0                       | 0    | 0     | 0 | 0                       | 0    | 0     | 0 | 0                        | 1    | 1     | 0 | 0                        | 0    | 0     | 0 | 2     | 24            |
| 8:20 PM                         | 0                       | 0    | 0     | 0 | 0                       | 0    | 0     | 0 | 0                        | 1    | 2     | 0 | 0                        | 1    | 0     | 0 | 4     | 25            |
| 8:25 PM                         | 0                       | 0    | 0     | 0 | 0                       | 0    | 0     | 0 | 0                        | 0    | 1     | 0 | 0                        | 0    | 0     | 0 | 1     | 21            |
| 8:30 PM                         | 0                       | 0    | 0     | 0 | 0                       | 0    | 0     | 0 | 0                        | 0    | 0     | 0 | 0                        | 0    | 0     | 0 | 0     | 19            |
| 8:35 PM                         | 0                       | 0    | 0     | 0 | 0                       | 0    | 0     | 0 | 0                        | 1    | 0     | 0 | 0                        | 1    | 0     | 0 | 2     | 18            |
| 8:40 PM                         | 0                       | 0    | 0     | 0 | 0                       | 0    | 0     | 0 | 1                        | 0    | 0     | 0 | 0                        | 0    | 0     | 0 | 1     | 18            |
| 8:45 PM                         | 0                       | 0    | 0     | 0 | 0                       | 0    | 1     | 0 | 0                        | 1    | 1     | 0 | 0                        | 0    | 0     | 0 | 3     | 19            |
| 8:50 PM                         | 0                       | 0    | 0     | 0 | 0                       | 0    | 0     | 0 | 1                        | 1    | 1     | 0 | 0                        | 0    | 0     | 0 | 3     | 21            |
| 8:55 PM                         | 0                       | 0    | 0     | 0 | 0                       | 0    | 0     | 0 | 0                        | 0    | 0     | 0 | 0                        | 0    | 0     | 0 | 0     | 19            |
| 9:00 PM                         | 0                       | 0    | 0     | 0 | 0                       | 0    | 0     | 0 | 2                        | 0    | 0     | 0 | 0                        | 0    | 0     | 0 | 2     | 20            |
| 9:05 PM                         | 0                       | 0    | 0     | 0 | 0                       | 0    | 0     | 0 | 0                        | 0    | 0     | 0 | 0                        | 0    | 0     | 0 | 0     | 19            |
| 9:10 PM                         | 0                       | 0    | 0     | 0 | 0                       | 0    | 0     | 0 | 0                        | 1    | 1     | 0 | 0                        | 1    | 0     | 0 | 3     | 21            |
| 9:15 PM                         | 0                       | 0    | 0     | 0 | 0                       | 0    | 0     | 0 | 0                        | 1    | 0     | 0 | 0                        | 0    | 0     | 0 | 1     | 20            |
| 9:20 PM                         | 0                       | 0    | 0     | 0 | 0                       | 0    | 0     | 0 | 0                        | 1    | 1     | 0 | 0                        | 0    | 0     | 0 | 2     | 18            |
| 9:25 PM                         | 0                       | 0    | 0     | 0 | 0                       | 0    | 0     | 0 | 0                        | 0    | 0     | 0 | 0                        | 0    | 0     | 0 | 0     | 17            |
| 9:30 PM                         | 0                       | 0    | 0     | 0 | 0                       | 0    | 0     | 0 | 1                        | 1    | 1     | 0 | 0                        | 0    | 0     | 0 | 3     | 20            |
| 9:35 PM                         | 0                       | 0    | 0     | 0 | 0                       | 0    | 0     | 0 | 1                        | 1    | 0     | 0 | 0                        | 0    | 0     | 0 | 2     | 20            |
| 9:40 PM                         | 1                       | 0    | 0     | 0 | 0                       | 0    | 0     | 0 | 0                        | 0    | 1     | 0 | 0                        | 0    | 0     | 0 | 2     | 21            |
| 9:45 PM                         | 1                       | 0    | 0     | 0 | 0                       | 0    | 0     | 0 | 0                        | 0    | 0     | 0 | 0                        | 0    | 0     | 0 | 1     | 19            |
| 9:50 PM                         | 0                       | 0    | 0     | 0 | 0                       | 0    | 0     | 0 | 0                        | 0    | 2     | 0 | 0                        | 0    | 0     | 0 | 2     | 18            |
| 9:55 PM                         | 0                       | 0    | 0     | 0 | 0                       | 0    | 0     | 0 | 0                        | 0    | 0     | 0 | 0                        | 0    | 0     | 0 | 0     | 18            |
| Peak 15-Min Flowrates           | Northbound              |      |       |   | Southbound              |      |       |   | Eastbound                |      |       |   | Westbound                |      |       |   | Total |               |
|                                 | Left                    | Thru | Right | U | Left                    | Thru | Right | U | Left                     | Thru | Right | U | Left                     | Thru | Right | U |       |               |
| All Vehicles                    | 8                       | 0    | 4     | 0 | 0                       | 8    | 8     | 0 | 16                       | 24   | 24    | 0 | 0                        | 4    | 0     | 0 | 96    |               |
| Heavy Trucks                    | 0                       | 0    | 4     |   | 0                       | 4    | 0     |   | 0                        | 4    | 0     |   | 0                        | 4    | 0     |   | 16    |               |
| Buses                           |                         |      |       |   |                         |      |       |   |                          |      |       |   |                          |      |       |   |       |               |
| Pedestrians                     |                         | 4    |       |   |                         | 0    |       |   |                          | 0    |       |   |                          | 0    |       |   | 4     |               |
| Bicycles                        | 0                       | 0    | 0     |   | 0                       | 0    | 0     |   | 0                        | 0    | 0     |   | 0                        | 0    | 0     |   | 0     |               |
| Scoters                         |                         |      |       |   |                         |      |       |   |                          |      |       |   |                          |      |       |   |       |               |
| <i>Comments:</i>                |                         |      |       |   |                         |      |       |   |                          |      |       |   |                          |      |       |   |       |               |

LOCATION: Ledgewood Dr -- Grassy Knoll Ln  
 CITY/STATE: Las Flores, CA

QC JOB #: 16966455  
 DATE: Wed, Apr 16 2025

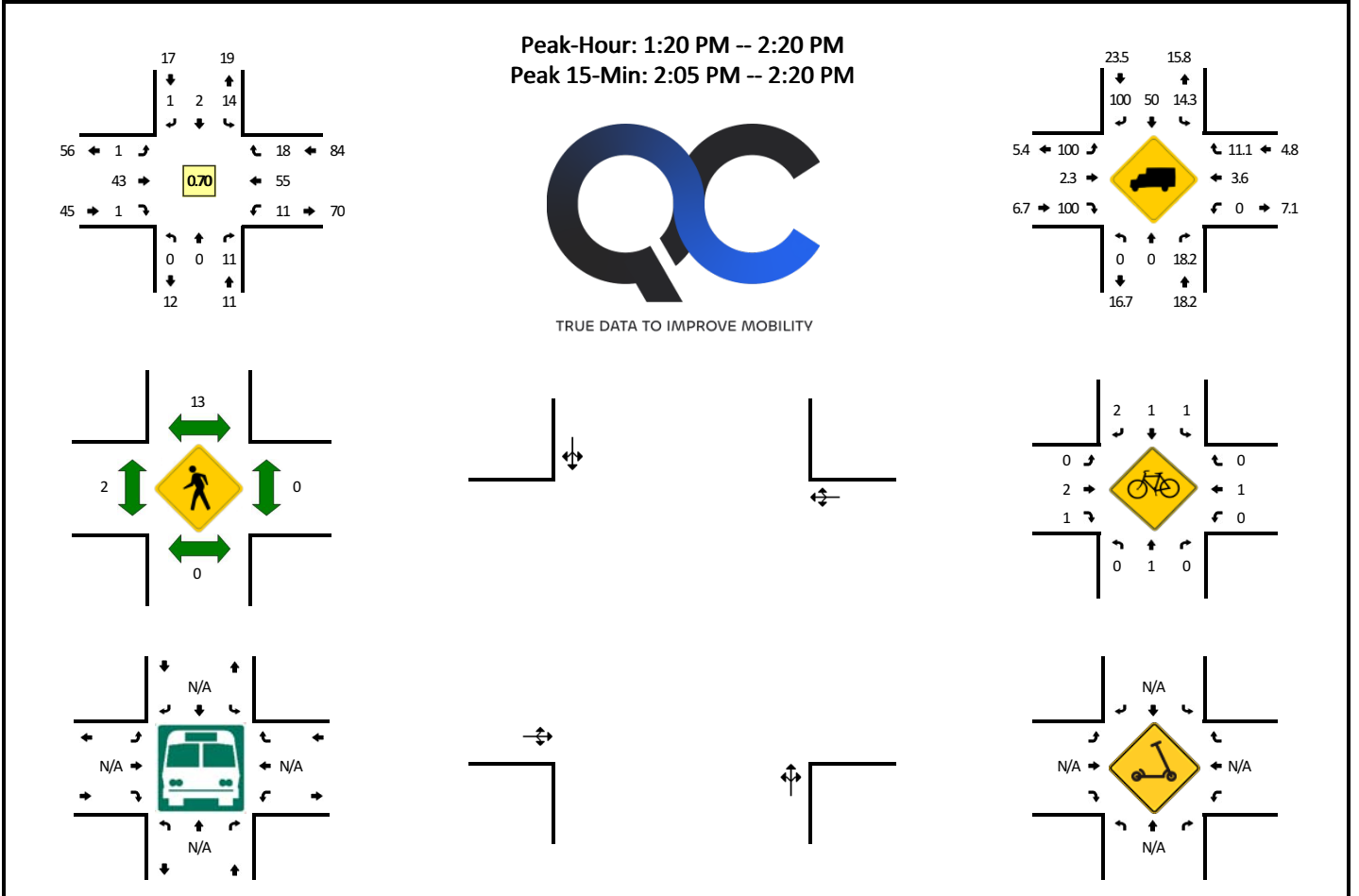

| 5-Min Count Period Beginning At | Ledgewood Dr (Northbound) |      |       |   | Ledgewood Dr (Southbound) |      |       |   | Grassy Knoll Ln (Eastbound) |      |       |   | Grassy Knoll Ln (Westbound) |      |       |   | Total | Hourly Totals |
|---------------------------------|---------------------------|------|-------|---|---------------------------|------|-------|---|-----------------------------|------|-------|---|-----------------------------|------|-------|---|-------|---------------|
|                                 | Left                      | Thru | Right | U | Left                      | Thru | Right | U | Left                        | Thru | Right | U | Left                        | Thru | Right | U |       |               |
| 6:00 AM                         | 0                         | 0    | 0     | 0 | 0                         | 0    | 0     | 0 | 0                           | 1    | 0     | 0 | 0                           | 0    | 0     | 0 | 1     |               |
| 6:05 AM                         | 0                         | 0    | 0     | 0 | 0                         | 0    | 0     | 0 | 0                           | 0    | 1     | 0 | 0                           | 0    | 0     | 0 | 1     |               |
| 6:10 AM                         | 0                         | 0    | 0     | 0 | 1                         | 0    | 0     | 0 | 0                           | 0    | 0     | 0 | 0                           | 0    | 0     | 0 | 1     |               |
| 6:15 AM                         | 0                         | 0    | 0     | 0 | 0                         | 0    | 0     | 0 | 0                           | 0    | 0     | 0 | 0                           | 0    | 0     | 0 | 0     |               |
| 6:20 AM                         | 0                         | 0    | 0     | 0 | 0                         | 0    | 1     | 0 | 0                           | 0    | 3     | 0 | 0                           | 0    | 1     | 1 | 0     | 6             |
| 6:25 AM                         | 0                         | 0    | 1     | 0 | 1                         | 0    | 0     | 0 | 0                           | 0    | 3     | 1 | 0                           | 0    | 3     | 0 | 0     | 9             |
| 6:30 AM                         | 0                         | 0    | 0     | 0 | 0                         | 0    | 0     | 0 | 0                           | 0    | 0     | 0 | 0                           | 1    | 0     | 0 | 0     | 1             |
| 6:35 AM                         | 0                         | 0    | 0     | 0 | 0                         | 0    | 0     | 0 | 0                           | 0    | 1     | 0 | 0                           | 0    | 0     | 0 | 0     | 1             |
| 6:40 AM                         | 0                         | 0    | 1     | 0 | 1                         | 0    | 0     | 0 | 0                           | 0    | 1     | 0 | 0                           | 0    | 0     | 0 | 0     | 3             |
| 6:45 AM                         | 0                         | 0    | 1     | 0 | 0                         | 0    | 0     | 0 | 0                           | 0    | 0     | 0 | 0                           | 0    | 0     | 0 | 0     | 1             |
| 6:50 AM                         | 0                         | 0    | 2     | 0 | 0                         | 0    | 0     | 0 | 0                           | 0    | 0     | 0 | 0                           | 1    | 0     | 0 | 0     | 3             |
| 6:55 AM                         | 0                         | 0    | 1     | 0 | 0                         | 0    | 0     | 0 | 0                           | 0    | 6     | 0 | 0                           | 0    | 0     | 0 | 0     | 7             |
| 7:00 AM                         | 0                         | 0    | 1     | 0 | 0                         | 0    | 0     | 0 | 0                           | 0    | 1     | 0 | 0                           | 0    | 0     | 0 | 0     | 2             |
| 7:05 AM                         | 0                         | 0    | 0     | 0 | 1                         | 0    | 0     | 0 | 0                           | 0    | 2     | 0 | 0                           | 0    | 1     | 0 | 0     | 4             |
| 7:10 AM                         | 0                         | 0    | 2     | 0 | 1                         | 0    | 0     | 0 | 0                           | 0    | 3     | 0 | 0                           | 0    | 0     | 1 | 0     | 7             |
| 7:15 AM                         | 0                         | 0    | 2     | 0 | 2                         | 0    | 0     | 0 | 0                           | 0    | 7     | 0 | 0                           | 1    | 1     | 1 | 0     | 14            |
| 7:20 AM                         | 0                         | 0    | 0     | 0 | 1                         | 0    | 0     | 0 | 0                           | 0    | 2     | 0 | 0                           | 1    | 3     | 0 | 0     | 7             |
| 7:25 AM                         | 0                         | 0    | 1     | 0 | 1                         | 1    | 0     | 0 | 0                           | 0    | 3     | 0 | 0                           | 0    | 1     | 0 | 0     | 7             |
| 7:30 AM                         | 0                         | 0    | 0     | 0 | 1                         | 0    | 0     | 0 | 0                           | 0    | 6     | 0 | 0                           | 0    | 2     | 1 | 0     | 10            |
| 7:35 AM                         | 0                         | 0    | 1     | 0 | 1                         | 0    | 0     | 0 | 0                           | 0    | 2     | 0 | 0                           | 1    | 2     | 3 | 0     | 10            |
| 7:40 AM                         | 0                         | 0    | 0     | 0 | 4                         | 0    | 0     | 0 | 0                           | 0    | 0     | 0 | 0                           | 0    | 1     | 1 | 0     | 6             |
| 7:45 AM                         | 0                         | 0    | 0     | 0 | 0                         | 0    | 0     | 0 | 0                           | 0    | 5     | 0 | 0                           | 0    | 1     | 0 | 0     | 6             |
| 7:50 AM                         | 0                         | 0    | 2     | 0 | 2                         | 0    | 0     | 0 | 0                           | 0    | 6     | 0 | 0                           | 0    | 3     | 1 | 0     | 14            |
| 7:55 AM                         | 0                         | 0    | 1     | 0 | 2                         | 0    | 1     | 0 | 0                           | 0    | 8     | 0 | 0                           | 0    | 5     | 1 | 0     | 18            |
| 8:00 AM                         | 0                         | 0    | 0     | 0 | 5                         | 0    | 0     | 0 | 0                           | 0    | 9     | 0 | 0                           | 0    | 5     | 1 | 0     | 20            |
| 8:05 AM                         | 0                         | 0    | 1     | 0 | 2                         | 0    | 0     | 0 | 0                           | 0    | 8     | 0 | 0                           | 1    | 2     | 1 | 0     | 15            |
| 8:10 AM                         | 0                         | 0    | 1     | 0 | 4                         | 0    | 0     | 0 | 0                           | 0    | 8     | 0 | 0                           | 0    | 3     | 1 | 0     | 17            |
| 8:15 AM                         | 0                         | 0    | 0     | 0 | 3                         | 0    | 0     | 0 | 0                           | 0    | 7     | 0 | 0                           | 0    | 4     | 2 | 0     | 16            |
| 8:20 AM                         | 0                         | 0    | 1     | 0 | 0                         | 0    | 0     | 0 | 0                           | 0    | 3     | 0 | 0                           | 0    | 4     | 1 | 0     | 9             |
| 8:25 AM                         | 0                         | 0    | 0     | 0 | 0                         | 1    | 0     | 0 | 0                           | 0    | 1     | 0 | 0                           | 0    | 1     | 3 | 0     | 6             |
| 8:30 AM                         | 1                         | 0    | 0     | 0 | 1                         | 0    | 0     | 0 | 0                           | 0    | 1     | 0 | 0                           | 1    | 2     | 1 | 0     | 7             |
| 8:35 AM                         | 0                         | 0    | 0     | 0 | 0                         | 0    | 0     | 0 | 0                           | 0    | 2     | 0 | 0                           | 2    | 2     | 1 | 0     | 7             |
| 8:40 AM                         | 0                         | 0    | 1     | 0 | 1                         | 0    | 0     | 0 | 0                           | 0    | 1     | 0 | 0                           | 0    | 2     | 0 | 0     | 5             |
| 8:45 AM                         | 0                         | 0    | 2     | 0 | 1                         | 0    | 0     | 0 | 0                           | 0    | 5     | 0 | 0                           | 0    | 0     | 1 | 0     | 9             |
| 8:50 AM                         | 0                         | 0    | 1     | 0 | 2                         | 0    | 0     | 0 | 0                           | 0    | 5     | 0 | 0                           | 1    | 1     | 0 | 0     | 10            |
| 8:55 AM                         | 0                         | 0    | 1     | 0 | 0                         | 0    | 0     | 0 | 0                           | 0    | 3     | 0 | 0                           | 0    | 0     | 0 | 0     | 4             |
| 9:00 AM                         | 0                         | 0    | 0     | 0 | 1                         | 0    | 0     | 0 | 0                           | 0    | 5     | 0 | 0                           | 0    | 0     | 1 | 0     | 7             |
| 9:05 AM                         | 0                         | 0    | 2     | 0 | 1                         | 0    | 0     | 0 | 0                           | 0    | 0     | 0 | 0                           | 1    | 0     | 0 | 0     | 4             |

Attachment B

| 5-Min Count Period Beginning At | Ledgewood Dr (Northbound) |      |       |   | Ledgewood Dr (Southbound) |      |       |   | Grassy Knoll Ln (Eastbound) |      |       |   | Grassy Knoll Ln (Westbound) |      |       |   | Total | Hourly Totals |
|---------------------------------|---------------------------|------|-------|---|---------------------------|------|-------|---|-----------------------------|------|-------|---|-----------------------------|------|-------|---|-------|---------------|
|                                 | Left                      | Thru | Right | U | Left                      | Thru | Right | U | Left                        | Thru | Right | U | Left                        | Thru | Right | U |       |               |
| 9:10 AM                         | 0                         | 0    | 0     | 0 | 1                         | 0    | 0     | 0 | 0                           | 2    | 0     | 0 | 1                           | 2    | 1     | 0 | 7     | 91            |
| 9:15 AM                         | 0                         | 0    | 0     | 0 | 0                         | 0    | 0     | 0 | 0                           | 2    | 0     | 0 | 0                           | 0    | 0     | 0 | 2     | 77            |
| 9:20 AM                         | 0                         | 0    | 0     | 0 | 0                         | 0    | 0     | 0 | 0                           | 4    | 0     | 0 | 0                           | 2    | 0     | 0 | 6     | 74            |
| 9:25 AM                         | 0                         | 0    | 2     | 0 | 0                         | 0    | 0     | 0 | 0                           | 2    | 0     | 0 | 0                           | 0    | 1     | 0 | 5     | 73            |
| 9:30 AM                         | 0                         | 0    | 0     | 0 | 1                         | 0    | 0     | 0 | 0                           | 2    | 0     | 0 | 1                           | 0    | 0     | 0 | 4     | 70            |
| 9:35 AM                         | 0                         | 0    | 0     | 0 | 0                         | 0    | 0     | 0 | 0                           | 3    | 0     | 0 | 0                           | 1    | 0     | 0 | 4     | 67            |
| 9:40 AM                         | 0                         | 0    | 0     | 0 | 1                         | 0    | 0     | 0 | 0                           | 3    | 0     | 0 | 0                           | 1    | 0     | 0 | 5     | 67            |
| 9:45 AM                         | 0                         | 0    | 1     | 0 | 0                         | 0    | 0     | 0 | 0                           | 3    | 0     | 0 | 1                           | 0    | 0     | 0 | 5     | 63            |
| 9:50 AM                         | 0                         | 0    | 0     | 0 | 1                         | 0    | 0     | 0 | 0                           | 0    | 0     | 0 | 0                           | 2    | 0     | 0 | 3     | 56            |
| 9:55 AM                         | 0                         | 0    | 0     | 0 | 1                         | 0    | 0     | 0 | 0                           | 0    | 0     | 0 | 0                           | 1    | 3     | 0 | 5     | 57            |
| 10:00 AM                        | 0                         | 0    | 1     | 0 | 0                         | 0    | 0     | 0 | 0                           | 1    | 0     | 0 | 0                           | 0    | 0     | 0 | 2     | 52            |
| 10:05 AM                        | 0                         | 0    | 0     | 0 | 2                         | 0    | 0     | 0 | 0                           | 1    | 0     | 0 | 2                           | 1    | 1     | 0 | 7     | 55            |
| 10:10 AM                        | 0                         | 0    | 0     | 0 | 0                         | 0    | 0     | 0 | 0                           | 0    | 0     | 0 | 0                           | 0    | 0     | 0 | 0     | 48            |
| 10:15 AM                        | 0                         | 0    | 0     | 0 | 0                         | 0    | 0     | 0 | 0                           | 1    | 0     | 0 | 0                           | 0    | 0     | 0 | 1     | 47            |
| 10:20 AM                        | 0                         | 0    | 1     | 0 | 0                         | 0    | 0     | 0 | 0                           | 0    | 0     | 0 | 1                           | 2    | 0     | 0 | 4     | 45            |
| 10:25 AM                        | 0                         | 0    | 1     | 0 | 1                         | 0    | 0     | 0 | 0                           | 3    | 0     | 0 | 1                           | 2    | 0     | 0 | 8     | 48            |
| 10:30 AM                        | 0                         | 0    | 1     | 0 | 1                         | 0    | 0     | 0 | 0                           | 1    | 0     | 0 | 0                           | 2    | 1     | 0 | 6     | 50            |
| 10:35 AM                        | 0                         | 0    | 2     | 0 | 0                         | 0    | 0     | 0 | 0                           | 1    | 0     | 0 | 0                           | 2    | 0     | 0 | 5     | 51            |
| 10:40 AM                        | 0                         | 0    | 1     | 0 | 1                         | 0    | 0     | 0 | 0                           | 1    | 0     | 0 | 1                           | 0    | 1     | 0 | 5     | 51            |
| 10:45 AM                        | 0                         | 0    | 0     | 0 | 0                         | 0    | 0     | 0 | 0                           | 1    | 0     | 0 | 0                           | 2    | 2     | 0 | 5     | 51            |
| 10:50 AM                        | 0                         | 0    | 0     | 0 | 1                         | 0    | 0     | 0 | 0                           | 2    | 0     | 0 | 1                           | 2    | 1     | 0 | 7     | 55            |
| 10:55 AM                        | 0                         | 0    | 1     | 0 | 0                         | 0    | 0     | 0 | 0                           | 0    | 0     | 0 | 0                           | 0    | 0     | 0 | 1     | 51            |
| 11:00 AM                        | 0                         | 0    | 0     | 0 | 1                         | 0    | 0     | 0 | 0                           | 2    | 0     | 0 | 1                           | 0    | 1     | 1 | 6     | 55            |
| 11:05 AM                        | 0                         | 0    | 0     | 0 | 0                         | 0    | 0     | 0 | 0                           | 2    | 0     | 0 | 2                           | 0    | 0     | 0 | 4     | 52            |
| 11:10 AM                        | 0                         | 0    | 1     | 0 | 2                         | 0    | 0     | 0 | 0                           | 1    | 0     | 0 | 0                           | 0    | 2     | 0 | 6     | 58            |
| 11:15 AM                        | 0                         | 0    | 0     | 0 | 1                         | 0    | 0     | 0 | 0                           | 1    | 0     | 0 | 0                           | 1    | 0     | 0 | 3     | 60            |
| 11:20 AM                        | 0                         | 0    | 1     | 0 | 2                         | 0    | 0     | 0 | 0                           | 1    | 0     | 0 | 2                           | 4    | 0     | 0 | 10    | 66            |
| 11:25 AM                        | 0                         | 0    | 0     | 0 | 1                         | 0    | 0     | 0 | 0                           | 3    | 0     | 0 | 1                           | 1    | 1     | 0 | 7     | 65            |
| 11:30 AM                        | 0                         | 0    | 1     | 0 | 1                         | 0    | 0     | 0 | 0                           | 1    | 0     | 0 | 2                           | 0    | 1     | 0 | 6     | 65            |
| 11:35 AM                        | 0                         | 0    | 1     | 0 | 0                         | 0    | 0     | 0 | 0                           | 2    | 0     | 0 | 1                           | 3    | 0     | 0 | 7     | 67            |
| 11:40 AM                        | 0                         | 0    | 0     | 0 | 0                         | 0    | 0     | 0 | 0                           | 0    | 0     | 0 | 0                           | 0    | 1     | 0 | 1     | 63            |
| 11:45 AM                        | 1                         | 1    | 1     | 0 | 2                         | 1    | 0     | 0 | 0                           | 3    | 0     | 0 | 1                           | 3    | 1     | 0 | 14    | 72            |
| 11:50 AM                        | 0                         | 0    | 0     | 0 | 0                         | 0    | 0     | 0 | 0                           | 2    | 0     | 0 | 0                           | 0    | 0     | 0 | 2     | 67            |
| 11:55 AM                        | 0                         | 0    | 1     | 0 | 0                         | 0    | 0     | 0 | 0                           | 0    | 0     | 0 | 0                           | 1    | 1     | 0 | 3     | 69            |
| 12:00 PM                        | 0                         | 0    | 0     | 0 | 0                         | 0    | 0     | 0 | 0                           | 2    | 0     | 0 | 1                           | 0    | 1     | 0 | 4     | 67            |
| 12:05 PM                        | 0                         | 0    | 2     | 0 | 1                         | 0    | 1     | 0 | 0                           | 0    | 0     | 0 | 0                           | 0    | 1     | 0 | 5     | 68            |
| 12:10 PM                        | 0                         | 0    | 0     | 0 | 1                         | 0    | 0     | 0 | 0                           | 0    | 0     | 0 | 1                           | 2    | 0     | 0 | 4     | 66            |
| 12:15 PM                        | 0                         | 0    | 2     | 0 | 1                         | 0    | 0     | 0 | 0                           | 0    | 0     | 0 | 0                           | 1    | 0     | 0 | 4     | 67            |
| 12:20 PM                        | 0                         | 0    | 0     | 0 | 0                         | 0    | 0     | 0 | 0                           | 0    | 0     | 0 | 0                           | 1    | 0     | 0 | 1     | 58            |
| 12:25 PM                        | 0                         | 0    | 2     | 0 | 1                         | 0    | 1     | 0 | 0                           | 3    | 0     | 0 | 1                           | 0    | 0     | 0 | 8     | 59            |
| 12:30 PM                        | 0                         | 0    | 2     | 0 | 0                         | 0    | 1     | 0 | 0                           | 1    | 0     | 0 | 0                           | 2    | 2     | 0 | 8     | 61            |
| 12:35 PM                        | 0                         | 0    | 0     | 0 | 2                         | 0    | 0     | 0 | 0                           | 4    | 0     | 0 | 0                           | 1    | 2     | 0 | 9     | 63            |
| 12:40 PM                        | 0                         | 0    | 0     | 0 | 1                         | 0    | 0     | 0 | 0                           | 1    | 0     | 0 | 1                           | 2    | 1     | 0 | 6     | 68            |
| 12:45 PM                        | 0                         | 0    | 0     | 0 | 1                         | 0    | 0     | 0 | 0                           | 3    | 0     | 0 | 0                           | 2    | 0     | 0 | 6     | 60            |
| 12:50 PM                        | 0                         | 0    | 2     | 0 | 1                         | 0    | 1     | 0 | 0                           | 1    | 0     | 0 | 1                           | 0    | 0     | 0 | 6     | 64            |
| 12:55 PM                        | 0                         | 0    | 1     | 0 | 1                         | 0    | 0     | 0 | 0                           | 3    | 0     | 0 | 0                           | 2    | 1     | 0 | 8     | 69            |
| 1:00 PM                         | 0                         | 0    | 0     | 0 | 0                         | 0    | 0     | 0 | 1                           | 2    | 0     | 0 | 0                           | 4    | 1     | 0 | 8     | 73            |
| 1:05 PM                         | 0                         | 0    | 0     | 0 | 1                         | 0    | 0     | 0 | 0                           | 2    | 0     | 0 | 1                           | 2    | 2     | 0 | 8     | 76            |
| 1:10 PM                         | 0                         | 0    | 0     | 0 | 1                         | 0    | 0     | 0 | 0                           | 3    | 0     | 0 | 3                           | 1    | 0     | 0 | 8     | 80            |
| 1:15 PM                         | 0                         | 0    | 2     | 0 | 0                         | 0    | 0     | 0 | 1                           | 0    | 1     | 0 | 1                           | 3    | 1     | 0 | 9     | 85            |
| 1:20 PM                         | 0                         | 0    | 0     | 0 | 2                         | 0    | 0     | 0 | 0                           | 2    | 0     | 0 | 0                           | 3    | 2     | 0 | 9     | 93            |
| 1:25 PM                         | 0                         | 0    | 0     | 0 | 1                         | 0    | 0     | 0 | 0                           | 1    | 0     | 0 | 2                           | 3    | 1     | 0 | 8     | 93            |
| 1:30 PM                         | 0                         | 0    | 2     | 0 | 0                         | 1    | 0     | 0 | 0                           | 4    | 0     | 0 | 0                           | 4    | 0     | 0 | 11    | 96            |
| 1:35 PM                         | 0                         | 0    | 3     | 0 | 0                         | 0    | 0     | 0 | 0                           | 0    | 0     | 0 | 2                           | 6    | 3     | 0 | 14    | 101           |
| 1:40 PM                         | 0                         | 0    | 4     | 0 | 1                         | 0    | 0     | 0 | 0                           | 3    | 0     | 0 | 0                           | 3    | 1     | 0 | 12    | 107           |
| 1:45 PM                         | 0                         | 0    | 0     | 0 | 0                         | 0    | 0     | 0 | 0                           | 2    | 0     | 0 | 0                           | 4    | 0     | 0 | 6     | 107           |
| 1:50 PM                         | 0                         | 0    | 1     | 0 | 1                         | 0    | 1     | 0 | 0                           | 3    | 0     | 0 | 0                           | 4    | 5     | 0 | 15    | 116           |
| 1:55 PM                         | 0                         | 0    | 0     | 0 | 2                         | 0    | 0     | 0 | 1                           | 2    | 1     | 0 | 2                           | 6    | 1     | 0 | 15    | 123           |
| 2:00 PM                         | 0                         | 0    | 1     | 0 | 0                         | 0    | 0     | 0 | 0                           | 1    | 0     | 0 | 0                           | 6    | 3     | 0 | 11    | 126           |
| 2:05 PM                         | 0                         | 0    | 0     | 0 | 1                         | 0    | 0     | 0 | 0                           | 2    | 0     | 0 | 2                           | 6    | 1     | 0 | 12    | 130           |
| 2:10 PM                         | 0                         | 0    | 0     | 0 | 5                         | 0    | 0     | 0 | 0                           | 11   | 0     | 0 | 0                           | 6    | 0     | 1 | 23    | 145           |
| 2:15 PM                         | 0                         | 0    | 0     | 0 | 1                         | 1    | 0     | 0 | 0                           | 12   | 0     | 0 | 1                           | 4    | 1     | 1 | 21    | 157           |
| 2:20 PM                         | 0                         | 0    | 1     | 0 | 0                         | 0    | 0     | 0 | 0                           | 5    | 0     | 0 | 0                           | 1    | 0     | 0 | 7     | 155           |
| 2:25 PM                         | 0                         | 0    | 0     | 0 | 0                         | 0    | 0     | 0 | 0                           | 3    | 0     | 0 | 0                           | 1    | 0     | 0 | 4     | 151           |
| 2:30 PM                         | 0                         | 0    | 1     | 0 | 1                         | 0    | 0     | 0 | 0                           | 2    | 0     | 0 | 0                           | 4    | 1     | 0 | 9     | 149           |
| 2:35 PM                         | 0                         | 0    | 1     | 0 | 0                         | 0    | 0     | 0 | 0                           | 2    | 0     | 0 | 1                           | 3    | 2     | 0 | 9     | 144           |
| 2:40 PM                         | 0                         | 0    | 0     | 0 | 2                         | 0    | 1     | 0 | 0                           | 1    | 0     | 0 | 1                           | 0    | 1     | 0 | 6     | 138           |
| 2:45 PM                         | 0                         | 1    | 1     | 0 | 1                         | 0    | 0     | 0 | 0                           | 2    | 0     | 0 | 1                           | 1    | 0     | 0 | 7     | 139           |
| 2:50 PM                         | 0                         | 0    | 1     | 0 | 1                         | 0    | 0     | 0 | 0                           | 3    | 0     | 0 | 1                           | 3    | 0     | 0 | 9     | 133           |
| 2:55 PM                         | 0                         | 0    | 0     | 0 | 3                         | 0    | 0     | 0 | 0                           | 0    | 0     | 0 | 0                           | 0    | 0     | 0 | 3     | 121           |
| 3:00 PM                         | 0                         | 0    | 2     | 0 | 1                         | 0    | 0     | 0 | 0                           | 2    | 0     | 0 | 2                           | 4    | 1     | 0 | 12    | 122           |
| 3:05 PM                         | 0                         | 0    | 0     | 0 | 1                         | 0    | 0     | 0 | 0                           | 5    | 0     | 0 | 0                           | 5    | 1     | 0 | 12    | 122           |
| 3:10 PM                         | 0                         | 0    | 4     | 0 | 0                         | 0    | 0     | 0 | 0                           | 0    | 0     | 0 | 0                           | 1    | 1     | 0 | 6     | 105           |
| 3:15 PM                         | 0                         | 0    | 1     | 0 | 1                         | 0    | 0     | 0 | 0                           | 5    | 0     | 0 | 1                           | 3    | 2     | 0 | 13    | 97            |
| 3:20 PM                         | 0                         | 0    | 1     | 0 | 2                         | 0    | 0     | 0 | 0                           | 3    | 0     | 0 | 0                           | 3    | 3     | 0 | 12    | 102           |
| 3:25 PM                         | 0                         | 0    | 1     | 0 | 1                         | 1    | 0     | 0 | 0                           | 1    | 0     | 0 | 0                           | 6    | 2     | 0 | 12    | 110           |
| 3:30 PM                         | 1                         | 0    | 1     | 0 | 0                         | 0    | 0     | 0 | 0                           | 3    | 0     | 0 | 2                           | 4    | 1     | 0 | 12    | 113           |
| 3:35 PM                         | 0                         | 0    | 0     | 0 | 2                         | 0    | 0     | 0 | 0                           | 3    | 0     | 0 | 0                           | 3    | 1     | 0 | 9     | 113           |
| 3:40 PM                         | 0                         | 0    | 0     | 0 | 0                         | 0    | 0     | 0 | 0                           | 4    | 0     | 0 | 3                           | 2    | 1     | 0 | 10    | 117           |
| 3:45 PM                         | 0                         | 0    | 1     | 0 | 2                         | 0    | 0     | 0 | 0                           | 0    | 0     | 0 | 0                           | 3    | 2     | 0 | 8     | 118           |
| 3:50 PM                         | 0                         | 0    | 2     | 0 | 1                         | 0    | 0     | 0 | 0                           | 3    | 0     | 0 | 1                           | 2    | 0     | 0 | 9     | 118           |
| 3:55 PM                         | 0                         | 0    | 0     | 0 | 1                         | 0    | 0     | 0 | 0                           | 2    | 0     | 0 | 0                           | 1    | 0     | 0 | 4     | 119           |
| 4:00 PM                         | 0                         | 0    | 1     | 0 | 1                         | 0    | 0     | 0 | 0                           | 2    | 0     | 0 | 1                           | 7    | 1     | 0 | 13    | 120           |
| 4:05 PM                         | 0                         | 0    | 1     | 0 | 2                         | 0    | 0     | 0 | 0                           | 6    | 0     | 0 | 1                           | 3    | 2     | 0 | 15    | 123           |
| 4:10 PM                         | 0                         | 0    | 0     | 0 | 1                         | 0    | 0     | 0 | 0                           | 2    | 0     | 0 | 1                           | 2    | 1     | 0 | 7     | 124           |
| 4:15 PM                         | 0                         | 0    | 0     | 0 | 0                         | 0    | 0     | 0 | 0                           | 0    | 0     | 0 | 0                           | 0    | 3     | 0 | 3     | 114           |
| 4:20 PM                         | 0                         | 0    | 0     | 0 | 0                         | 0    | 0     | 0 | 0                           | 1    | 0     | 0 | 0                           | 3    | 2     | 0 | 6     | 108           |
| 4:25 PM                         | 0                         | 0    | 0     | 0 | 2                         | 0    | 0     | 0 | 0                           | 4    | 0     | 0 | 0                           | 5    | 2     | 0 | 13    | 109           |

**Attachment B**

| 5-Min Count Period Beginning At | Ledgewood Dr (Northbound) |      |       |   | Ledgewood Dr (Southbound) |      |       |   | Grassy Knoll Ln (Eastbound) |      |       |   | Grassy Knoll Ln (Westbound) |      |       |   | Total | Hourly Totals |
|---------------------------------|---------------------------|------|-------|---|---------------------------|------|-------|---|-----------------------------|------|-------|---|-----------------------------|------|-------|---|-------|---------------|
|                                 | Left                      | Thru | Right | U | Left                      | Thru | Right | U | Left                        | Thru | Right | U | Left                        | Thru | Right | U |       |               |
| 4:30 PM                         | 0                         | 0    | 0     | 0 | 0                         | 0    | 0     | 0 | 0                           | 2    | 0     | 0 | 3                           | 1    | 1     | 0 | 7     | 104           |
| 4:35 PM                         | 0                         | 2    | 0     | 0 | 5                         | 0    | 0     | 0 | 0                           | 1    | 0     | 0 | 0                           | 2    | 0     | 0 | 10    | 105           |
| 4:40 PM                         | 0                         | 0    | 0     | 0 | 0                         | 0    | 0     | 0 | 0                           | 2    | 0     | 0 | 1                           | 1    | 0     | 0 | 4     | 99            |
| 4:45 PM                         | 0                         | 0    | 1     | 0 | 0                         | 0    | 0     | 0 | 0                           | 3    | 0     | 0 | 1                           | 2    | 0     | 0 | 7     | 98            |
| 4:50 PM                         | 0                         | 0    | 1     | 0 | 1                         | 0    | 0     | 0 | 0                           | 2    | 0     | 0 | 0                           | 1    | 0     | 0 | 5     | 94            |
| 4:55 PM                         | 0                         | 0    | 0     | 0 | 1                         | 0    | 0     | 0 | 0                           | 1    | 0     | 0 | 2                           | 7    | 2     | 0 | 13    | 103           |
| 5:00 PM                         | 0                         | 0    | 0     | 0 | 0                         | 0    | 0     | 0 | 0                           | 2    | 0     | 0 | 1                           | 1    | 2     | 0 | 6     | 96            |
| 5:05 PM                         | 0                         | 0    | 0     | 0 | 2                         | 0    | 0     | 0 | 0                           | 0    | 0     | 0 | 0                           | 5    | 1     | 0 | 8     | 89            |
| 5:10 PM                         | 0                         | 0    | 0     | 0 | 0                         | 0    | 0     | 0 | 0                           | 0    | 0     | 0 | 0                           | 2    | 2     | 0 | 4     | 86            |
| 5:15 PM                         | 0                         | 0    | 0     | 0 | 2                         | 0    | 0     | 0 | 0                           | 3    | 0     | 0 | 1                           | 3    | 1     | 0 | 10    | 93            |
| 5:20 PM                         | 0                         | 0    | 0     | 0 | 3                         | 0    | 0     | 0 | 0                           | 2    | 0     | 0 | 1                           | 3    | 0     | 0 | 9     | 96            |
| 5:25 PM                         | 0                         | 0    | 1     | 0 | 1                         | 0    | 0     | 0 | 0                           | 3    | 0     | 0 | 0                           | 7    | 2     | 0 | 14    | 97            |
| 5:30 PM                         | 0                         | 0    | 0     | 0 | 3                         | 0    | 0     | 0 | 0                           | 1    | 0     | 0 | 0                           | 3    | 2     | 0 | 9     | 99            |
| 5:35 PM                         | 0                         | 0    | 0     | 0 | 0                         | 0    | 0     | 0 | 0                           | 1    | 0     | 0 | 2                           | 2    | 1     | 0 | 6     | 95            |
| 5:40 PM                         | 0                         | 0    | 0     | 0 | 1                         | 0    | 0     | 0 | 0                           | 3    | 0     | 0 | 3                           | 4    | 1     | 0 | 12    | 103           |
| 5:45 PM                         | 0                         | 0    | 1     | 0 | 1                         | 0    | 0     | 0 | 0                           | 0    | 0     | 0 | 1                           | 4    | 1     | 0 | 8     | 104           |
| 5:50 PM                         | 0                         | 0    | 0     | 0 | 1                         | 0    | 0     | 0 | 0                           | 5    | 0     | 0 | 1                           | 2    | 0     | 0 | 10    | 109           |
| 5:55 PM                         | 0                         | 0    | 0     | 0 | 1                         | 0    | 0     | 0 | 0                           | 2    | 0     | 0 | 0                           | 4    | 3     | 0 | 10    | 106           |
| 6:00 PM                         | 0                         | 0    | 2     | 0 | 0                         | 0    | 0     | 0 | 0                           | 4    | 0     | 0 | 1                           | 2    | 1     | 0 | 10    | 110           |
| 6:05 PM                         | 0                         | 0    | 1     | 0 | 1                         | 0    | 0     | 0 | 0                           | 3    | 0     | 0 | 3                           | 4    | 2     | 0 | 14    | 116           |
| 6:10 PM                         | 0                         | 0    | 1     | 0 | 0                         | 0    | 0     | 0 | 0                           | 0    | 0     | 0 | 0                           | 3    | 0     | 0 | 4     | 116           |
| 6:15 PM                         | 0                         | 0    | 1     | 0 | 0                         | 0    | 0     | 0 | 0                           | 0    | 0     | 0 | 1                           | 4    | 1     | 0 | 7     | 113           |
| 6:20 PM                         | 0                         | 0    | 0     | 0 | 0                         | 0    | 0     | 0 | 0                           | 2    | 0     | 0 | 0                           | 2    | 0     | 0 | 4     | 108           |
| 6:25 PM                         | 0                         | 0    | 0     | 0 | 0                         | 0    | 0     | 0 | 0                           | 5    | 0     | 0 | 1                           | 0    | 2     | 0 | 8     | 102           |
| 6:30 PM                         | 0                         | 0    | 0     | 0 | 0                         | 0    | 0     | 0 | 0                           | 1    | 0     | 0 | 1                           | 0    | 2     | 0 | 4     | 97            |
| 6:35 PM                         | 0                         | 0    | 0     | 0 | 1                         | 0    | 0     | 0 | 0                           | 2    | 0     | 0 | 1                           | 2    | 0     | 0 | 6     | 97            |
| 6:40 PM                         | 0                         | 0    | 0     | 0 | 0                         | 0    | 0     | 0 | 0                           | 2    | 0     | 0 | 0                           | 1    | 0     | 0 | 3     | 88            |
| 6:45 PM                         | 0                         | 0    | 2     | 0 | 2                         | 0    | 0     | 0 | 0                           | 1    | 0     | 0 | 1                           | 4    | 1     | 0 | 11    | 91            |
| 6:50 PM                         | 0                         | 0    | 1     | 0 | 0                         | 0    | 0     | 0 | 0                           | 2    | 0     | 0 | 2                           | 4    | 1     | 0 | 10    | 91            |
| 6:55 PM                         | 0                         | 0    | 0     | 0 | 1                         | 0    | 0     | 0 | 0                           | 1    | 0     | 0 | 0                           | 2    | 1     | 0 | 5     | 86            |
| 7:00 PM                         | 0                         | 0    | 0     | 0 | 0                         | 0    | 1     | 0 | 0                           | 3    | 0     | 0 | 1                           | 3    | 0     | 0 | 8     | 84            |
| 7:05 PM                         | 0                         | 0    | 0     | 0 | 0                         | 0    | 0     | 0 | 0                           | 1    | 0     | 0 | 2                           | 3    | 1     | 0 | 7     | 77            |
| 7:10 PM                         | 0                         | 0    | 0     | 0 | 2                         | 0    | 0     | 0 | 0                           | 3    | 0     | 0 | 0                           | 1    | 0     | 0 | 6     | 79            |
| 7:15 PM                         | 0                         | 0    | 0     | 0 | 2                         | 0    | 0     | 0 | 0                           | 2    | 0     | 0 | 0                           | 1    | 1     | 0 | 6     | 78            |
| 7:20 PM                         | 0                         | 0    | 0     | 0 | 1                         | 0    | 0     | 0 | 0                           | 0    | 0     | 0 | 0                           | 5    | 2     | 0 | 8     | 82            |
| 7:25 PM                         | 0                         | 0    | 0     | 0 | 0                         | 0    | 0     | 0 | 0                           | 0    | 0     | 0 | 1                           | 3    | 1     | 0 | 5     | 79            |
| 7:30 PM                         | 0                         | 0    | 0     | 0 | 0                         | 0    | 0     | 0 | 0                           | 4    | 0     | 0 | 2                           | 2    | 1     | 0 | 9     | 84            |
| 7:35 PM                         | 0                         | 0    | 2     | 0 | 0                         | 0    | 0     | 0 | 0                           | 1    | 0     | 0 | 0                           | 3    | 0     | 0 | 6     | 84            |
| 7:40 PM                         | 0                         | 0    | 1     | 0 | 0                         | 0    | 0     | 0 | 0                           | 1    | 0     | 0 | 0                           | 3    | 2     | 0 | 7     | 88            |
| 7:45 PM                         | 0                         | 0    | 0     | 0 | 1                         | 0    | 0     | 0 | 0                           | 0    | 0     | 0 | 0                           | 5    | 3     | 0 | 9     | 86            |
| 7:50 PM                         | 0                         | 0    | 0     | 0 | 0                         | 1    | 0     | 0 | 0                           | 1    | 0     | 0 | 1                           | 3    | 1     | 0 | 7     | 83            |
| 7:55 PM                         | 0                         | 0    | 0     | 0 | 0                         | 0    | 0     | 0 | 0                           | 0    | 0     | 0 | 1                           | 3    | 0     | 0 | 4     | 82            |
| 8:00 PM                         | 0                         | 0    | 0     | 0 | 0                         | 0    | 0     | 0 | 0                           | 1    | 0     | 0 | 0                           | 1    | 0     | 0 | 2     | 76            |
| 8:05 PM                         | 0                         | 0    | 2     | 0 | 1                         | 0    | 0     | 0 | 0                           | 1    | 0     | 0 | 0                           | 4    | 0     | 0 | 8     | 77            |
| 8:10 PM                         | 0                         | 0    | 2     | 0 | 0                         | 0    | 0     | 0 | 0                           | 0    | 0     | 0 | 0                           | 1    | 2     | 0 | 5     | 76            |
| 8:15 PM                         | 0                         | 0    | 1     | 0 | 0                         | 0    | 0     | 0 | 0                           | 0    | 0     | 0 | 2                           | 2    | 0     | 0 | 5     | 75            |
| 8:20 PM                         | 0                         | 0    | 0     | 0 | 2                         | 0    | 0     | 0 | 0                           | 0    | 0     | 0 | 0                           | 3    | 0     | 0 | 5     | 72            |
| 8:25 PM                         | 0                         | 0    | 0     | 0 | 0                         | 0    | 0     | 0 | 0                           | 1    | 0     | 0 | 0                           | 1    | 3     | 0 | 5     | 72            |
| 8:30 PM                         | 0                         | 0    | 0     | 0 | 0                         | 0    | 0     | 0 | 0                           | 0    | 0     | 0 | 0                           | 0    | 1     | 0 | 1     | 64            |
| 8:35 PM                         | 0                         | 0    | 2     | 0 | 0                         | 0    | 0     | 0 | 0                           | 0    | 0     | 0 | 0                           | 6    | 0     | 0 | 8     | 66            |
| 8:40 PM                         | 0                         | 0    | 1     | 0 | 0                         | 0    | 0     | 0 | 0                           | 1    | 0     | 0 | 0                           | 1    | 0     | 0 | 3     | 62            |
| 8:45 PM                         | 0                         | 0    | 0     | 0 | 0                         | 0    | 0     | 0 | 0                           | 0    | 0     | 0 | 2                           | 4    | 0     | 0 | 6     | 59            |
| 8:50 PM                         | 0                         | 0    | 1     | 0 | 0                         | 0    | 0     | 0 | 0                           | 1    | 0     | 0 | 0                           | 0    | 0     | 0 | 2     | 54            |
| 8:55 PM                         | 0                         | 0    | 0     | 0 | 0                         | 0    | 0     | 0 | 0                           | 0    | 0     | 0 | 2                           | 0    | 1     | 0 | 3     | 53            |
| 9:00 PM                         | 0                         | 0    | 0     | 0 | 1                         | 0    | 0     | 0 | 0                           | 0    | 0     | 0 | 0                           | 0    | 0     | 0 | 1     | 52            |
| 9:05 PM                         | 0                         | 0    | 0     | 0 | 0                         | 0    | 0     | 0 | 0                           | 1    | 0     | 0 | 1                           | 0    | 0     | 0 | 2     | 46            |
| 9:10 PM                         | 0                         | 0    | 0     | 0 | 0                         | 0    | 0     | 0 | 0                           | 0    | 0     | 0 | 0                           | 1    | 0     | 0 | 1     | 42            |
| 9:15 PM                         | 0                         | 0    | 0     | 0 | 0                         | 0    | 0     | 0 | 0                           | 2    | 0     | 0 | 2                           | 1    | 1     | 0 | 6     | 43            |
| 9:20 PM                         | 0                         | 0    | 0     | 0 | 0                         | 0    | 0     | 0 | 0                           | 1    | 0     | 0 | 2                           | 3    | 2     | 0 | 8     | 46            |
| 9:25 PM                         | 0                         | 0    | 1     | 0 | 0                         | 0    | 0     | 0 | 0                           | 0    | 0     | 0 | 0                           | 4    | 0     | 0 | 5     | 46            |
| 9:30 PM                         | 0                         | 0    | 0     | 0 | 0                         | 0    | 0     | 0 | 0                           | 1    | 0     | 0 | 0                           | 0    | 1     | 0 | 2     | 47            |
| 9:35 PM                         | 0                         | 0    | 0     | 0 | 0                         | 0    | 0     | 0 | 0                           | 0    | 0     | 0 | 0                           | 0    | 0     | 0 | 0     | 39            |
| 9:40 PM                         | 0                         | 0    | 0     | 0 | 0                         | 0    | 0     | 0 | 0                           | 0    | 0     | 0 | 0                           | 1    | 0     | 0 | 1     | 37            |
| 9:45 PM                         | 0                         | 0    | 1     | 0 | 0                         | 0    | 0     | 0 | 0                           | 1    | 0     | 0 | 0                           | 1    | 0     | 0 | 3     | 34            |
| 9:50 PM                         | 0                         | 0    | 0     | 0 | 0                         | 0    | 0     | 0 | 0                           | 0    | 0     | 0 | 0                           | 1    | 0     | 0 | 1     | 33            |
| 9:55 PM                         | 0                         | 0    | 0     | 0 | 0                         | 0    | 0     | 0 | 0                           | 0    | 0     | 0 | 0                           | 1    | 1     | 0 | 2     | 32            |
| Peak 15-Min Flowrates           | Northbound                |      |       |   | Southbound                |      |       |   | Eastbound                   |      |       |   | Westbound                   |      |       |   | Total |               |
|                                 | Left                      | Thru | Right | U | Left                      | Thru | Right | U | Left                        | Thru | Right | U | Left                        | Thru | Right | U |       |               |
| All Vehicles                    | 0                         | 0    | 0     | 0 | 28                        | 4    | 0     | 0 | 0                           | 100  | 0     | 0 | 12                          | 64   | 8     | 8 | 224   |               |
| Heavy Trucks                    | 0                         | 0    | 0     | 0 | 4                         | 0    | 0     | 0 | 0                           | 4    | 0     | 0 | 0                           | 0    | 0     | 0 | 8     |               |
| Buses                           |                           |      |       |   |                           |      |       |   |                             |      |       |   |                             |      |       |   |       |               |
| Pedestrians                     |                           | 0    |       |   |                           | 28   |       |   |                             | 4    |       |   |                             | 0    |       |   | 32    |               |
| Bicycles                        | 0                         | 4    | 0     |   | 4                         | 0    | 4     |   | 0                           | 8    | 4     |   | 0                           | 0    | 0     |   | 24    |               |
| Scoters                         |                           |      |       |   |                           |      |       |   |                             |      |       |   |                             |      |       |   |       |               |

*Comments:*  
 Report generated on 4/25/2025 4:03 PM SOURCE: Quality Counts, LLC (<http://www.qualitycounts.net>) 1-877-580-2212

LOCATION: Shea Ridge -- Rolling Ridge  
 CITY/STATE: Las Flores, CA

QC JOB #: 16966456  
 DATE: Wed, Apr 16 2025

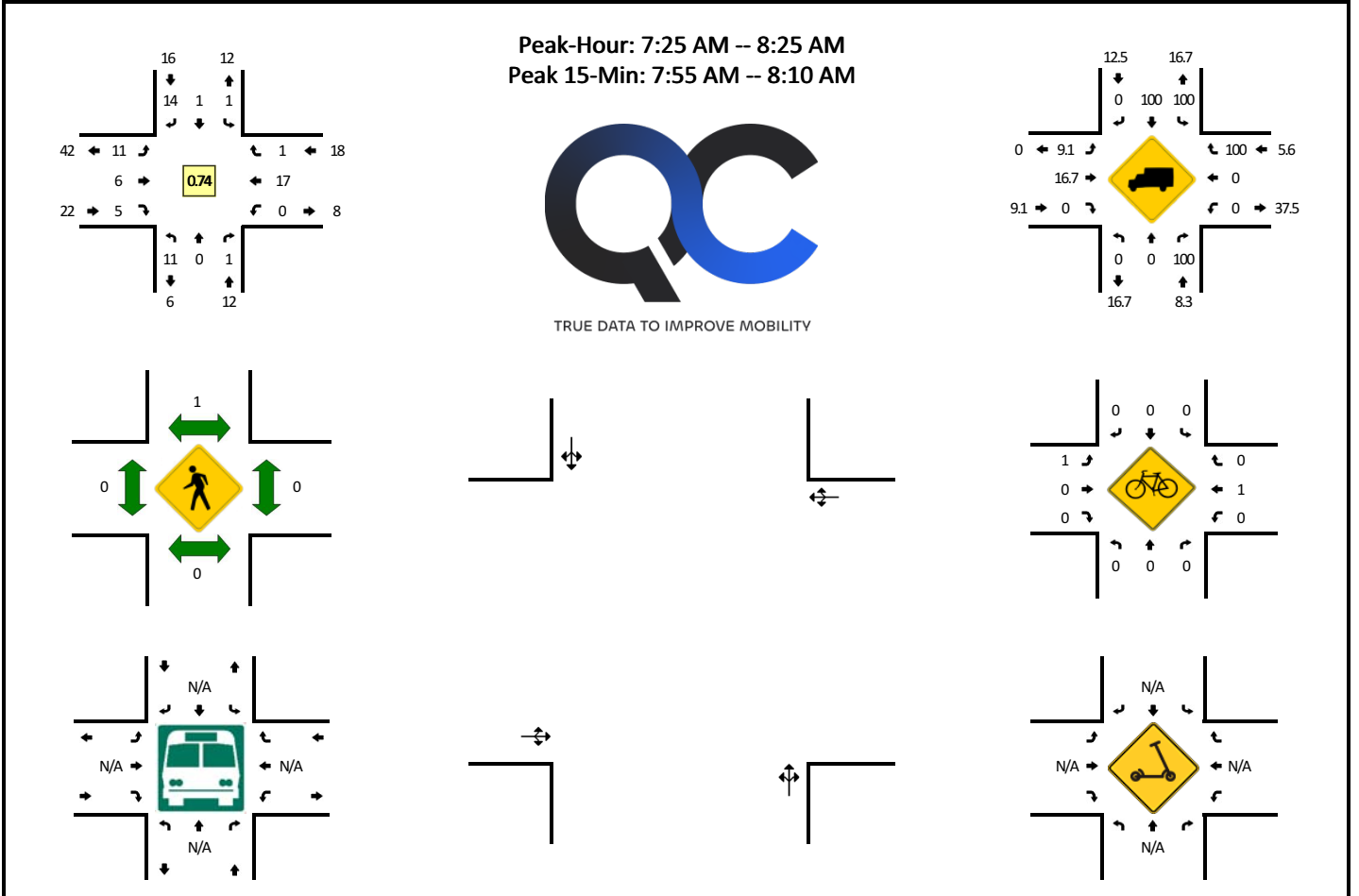

| 5-Min Count Period Beginning At | Shea Ridge (Northbound) |      |       |   | Shea Ridge (Southbound) |      |       |   | Rolling Ridge (Eastbound) |      |       |   | Rolling Ridge (Westbound) |      |       |   | Total | Hourly Totals |
|---------------------------------|-------------------------|------|-------|---|-------------------------|------|-------|---|---------------------------|------|-------|---|---------------------------|------|-------|---|-------|---------------|
|                                 | Left                    | Thru | Right | U | Left                    | Thru | Right | U | Left                      | Thru | Right | U | Left                      | Thru | Right | U |       |               |
| 6:00 AM                         | 1                       | 0    | 0     | 0 | 0                       | 0    | 0     | 0 | 0                         | 0    | 0     | 0 | 0                         | 0    | 0     | 0 | 1     |               |
| 6:05 AM                         | 0                       | 0    | 0     | 0 | 0                       | 0    | 1     | 0 | 0                         | 0    | 1     | 0 | 0                         | 0    | 0     | 0 | 2     |               |
| 6:10 AM                         | 0                       | 0    | 0     | 0 | 0                       | 0    | 0     | 0 | 0                         | 0    | 0     | 0 | 0                         | 0    | 0     | 0 | 0     |               |
| 6:15 AM                         | 0                       | 0    | 0     | 0 | 1                       | 0    | 0     | 0 | 1                         | 1    | 0     | 0 | 0                         | 1    | 0     | 0 | 4     |               |
| 6:20 AM                         | 1                       | 0    | 0     | 0 | 0                       | 0    | 0     | 0 | 1                         | 0    | 0     | 0 | 0                         | 0    | 0     | 0 | 2     |               |
| 6:25 AM                         | 1                       | 0    | 0     | 0 | 0                       | 0    | 1     | 0 | 0                         | 0    | 0     | 0 | 0                         | 0    | 0     | 0 | 2     |               |
| 6:30 AM                         | 0                       | 0    | 0     | 0 | 0                       | 0    | 2     | 0 | 1                         | 0    | 0     | 0 | 0                         | 1    | 0     | 0 | 4     |               |
| 6:35 AM                         | 0                       | 0    | 0     | 0 | 0                       | 0    | 0     | 0 | 0                         | 0    | 0     | 0 | 0                         | 0    | 0     | 0 | 0     |               |
| 6:40 AM                         | 0                       | 0    | 0     | 0 | 0                       | 0    | 1     | 0 | 1                         | 0    | 0     | 0 | 0                         | 0    | 0     | 0 | 2     |               |
| 6:45 AM                         | 0                       | 0    | 0     | 0 | 0                       | 0    | 0     | 0 | 0                         | 0    | 0     | 0 | 0                         | 0    | 0     | 0 | 0     |               |
| 6:50 AM                         | 0                       | 0    | 0     | 0 | 0                       | 0    | 1     | 0 | 0                         | 0    | 0     | 0 | 0                         | 0    | 0     | 0 | 1     |               |
| 6:55 AM                         | 0                       | 1    | 0     | 0 | 0                       | 0    | 0     | 0 | 0                         | 0    | 0     | 0 | 1                         | 1    | 0     | 0 | 3     | 21            |
| 7:00 AM                         | 3                       | 0    | 0     | 0 | 0                       | 0    | 2     | 0 | 0                         | 1    | 0     | 0 | 0                         | 2    | 0     | 0 | 8     | 28            |
| 7:05 AM                         | 0                       | 0    | 0     | 0 | 0                       | 0    | 1     | 0 | 0                         | 0    | 0     | 0 | 0                         | 1    | 0     | 0 | 2     | 28            |
| 7:10 AM                         | 0                       | 0    | 0     | 0 | 0                       | 0    | 6     | 0 | 0                         | 0    | 0     | 0 | 0                         | 1    | 0     | 0 | 7     | 35            |
| 7:15 AM                         | 0                       | 0    | 0     | 0 | 0                       | 0    | 3     | 0 | 0                         | 1    | 0     | 0 | 0                         | 0    | 0     | 0 | 4     | 35            |
| 7:20 AM                         | 0                       | 0    | 0     | 0 | 0                       | 0    | 1     | 0 | 1                         | 1    | 0     | 0 | 0                         | 0    | 0     | 0 | 3     | 36            |
| 7:25 AM                         | 3                       | 0    | 0     | 0 | 0                       | 0    | 1     | 0 | 1                         | 0    | 0     | 0 | 0                         | 3    | 0     | 0 | 8     | 42            |
| 7:30 AM                         | 0                       | 0    | 0     | 0 | 0                       | 0    | 1     | 0 | 0                         | 0    | 1     | 0 | 0                         | 3    | 0     | 0 | 5     | 43            |
| 7:35 AM                         | 1                       | 0    | 0     | 0 | 0                       | 0    | 1     | 0 | 1                         | 1    | 0     | 0 | 0                         | 0    | 0     | 0 | 4     | 47            |
| 7:40 AM                         | 2                       | 0    | 0     | 0 | 1                       | 0    | 1     | 0 | 1                         | 0    | 0     | 0 | 0                         | 0    | 0     | 0 | 5     | 50            |
| 7:45 AM                         | 1                       | 0    | 0     | 0 | 0                       | 0    | 0     | 0 | 0                         | 1    | 0     | 0 | 0                         | 0    | 1     | 0 | 3     | 53            |
| 7:50 AM                         | 0                       | 0    | 0     | 0 | 0                       | 0    | 2     | 0 | 0                         | 0    | 0     | 0 | 0                         | 1    | 0     | 0 | 3     | 55            |
| 7:55 AM                         | 0                       | 0    | 0     | 0 | 0                       | 1    | 2     | 0 | 0                         | 0    | 1     | 0 | 0                         | 5    | 0     | 0 | 9     | 61            |
| 8:00 AM                         | 2                       | 0    | 0     | 0 | 0                       | 0    | 1     | 0 | 0                         | 2    | 0     | 0 | 0                         | 0    | 0     | 0 | 5     | 58            |
| 8:05 AM                         | 0                       | 0    | 1     | 0 | 0                       | 0    | 2     | 0 | 1                         | 0    | 3     | 0 | 0                         | 2    | 0     | 0 | 9     | 65            |
| 8:10 AM                         | 1                       | 0    | 0     | 0 | 0                       | 0    | 1     | 0 | 2                         | 1    | 0     | 0 | 0                         | 1    | 0     | 0 | 6     | 64            |
| 8:15 AM                         | 0                       | 0    | 0     | 0 | 0                       | 0    | 2     | 0 | 1                         | 1    | 0     | 0 | 0                         | 2    | 0     | 0 | 6     | 66            |
| 8:20 AM                         | 1                       | 0    | 0     | 0 | 0                       | 0    | 0     | 0 | 4                         | 0    | 0     | 0 | 0                         | 0    | 0     | 0 | 5     | 68            |
| 8:25 AM                         | 2                       | 0    | 0     | 0 | 0                       | 0    | 2     | 0 | 0                         | 1    | 1     | 0 | 0                         | 1    | 0     | 0 | 7     | 67            |
| 8:30 AM                         | 0                       | 0    | 0     | 0 | 0                       | 0    | 1     | 0 | 1                         | 0    | 0     | 0 | 0                         | 0    | 0     | 0 | 2     | 64            |
| 8:35 AM                         | 1                       | 0    | 0     | 0 | 0                       | 0    | 2     | 0 | 0                         | 0    | 1     | 0 | 0                         | 3    | 0     | 0 | 7     | 67            |
| 8:40 AM                         | 0                       | 0    | 0     | 0 | 0                       | 0    | 0     | 0 | 2                         | 0    | 0     | 0 | 0                         | 0    | 0     | 0 | 2     | 64            |
| 8:45 AM                         | 1                       | 0    | 0     | 0 | 0                       | 0    | 1     | 0 | 1                         | 0    | 0     | 0 | 0                         | 1    | 0     | 0 | 4     | 65            |
| 8:50 AM                         | 1                       | 0    | 0     | 0 | 0                       | 0    | 3     | 0 | 1                         | 0    | 0     | 0 | 0                         | 1    | 0     | 0 | 6     | 68            |
| 8:55 AM                         | 0                       | 0    | 0     | 0 | 0                       | 0    | 0     | 0 | 0                         | 2    | 0     | 0 | 0                         | 1    | 0     | 0 | 3     | 62            |
| 9:00 AM                         | 0                       | 0    | 0     | 0 | 0                       | 0    | 0     | 0 | 0                         | 0    | 1     | 0 | 0                         | 1    | 0     | 0 | 2     | 59            |
| 9:05 AM                         | 0                       | 0    | 0     | 0 | 0                       | 0    | 2     | 0 | 1                         | 0    | 0     | 0 | 0                         | 0    | 0     | 0 | 3     | 53            |

### Attachment B

| 5-Min Count<br>Period<br>Beginning At | Shea Ridge<br>(Northbound) |      |       |   | Shea Ridge<br>(Southbound) |      |       |   | Rolling Ridge<br>(Eastbound) |      |       |   | Rolling Ridge<br>(Westbound) |      |       |   | Total | Hourly<br>Totals |
|---------------------------------------|----------------------------|------|-------|---|----------------------------|------|-------|---|------------------------------|------|-------|---|------------------------------|------|-------|---|-------|------------------|
|                                       | Left                       | Thru | Right | U | Left                       | Thru | Right | U | Left                         | Thru | Right | U | Left                         | Thru | Right | U |       |                  |
| 9:10 AM                               | 0                          | 0    | 0     | 0 | 0                          | 1    | 2     | 0 | 1                            | 1    | 0     | 0 | 0                            | 0    | 0     | 0 | 5     | 52               |
| 9:15 AM                               | 0                          | 0    | 0     | 0 | 0                          | 0    | 1     | 0 | 0                            | 2    | 1     | 0 | 0                            | 0    | 1     | 0 | 5     | 51               |
| 9:20 AM                               | 0                          | 0    | 1     | 0 | 0                          | 0    | 0     | 0 | 0                            | 0    | 0     | 0 | 0                            | 0    | 0     | 0 | 1     | 47               |
| 9:25 AM                               | 1                          | 0    | 0     | 0 | 0                          | 0    | 1     | 0 | 3                            | 0    | 3     | 0 | 0                            | 0    | 0     | 0 | 8     | 48               |
| 9:30 AM                               | 0                          | 0    | 0     | 0 | 0                          | 0    | 1     | 0 | 2                            | 1    | 1     | 0 | 0                            | 0    | 1     | 0 | 6     | 52               |
| 9:35 AM                               | 0                          | 0    | 0     | 0 | 0                          | 0    | 2     | 0 | 1                            | 0    | 0     | 0 | 0                            | 0    | 1     | 0 | 4     | 49               |
| 9:40 AM                               | 2                          | 0    | 0     | 0 | 0                          | 0    | 1     | 0 | 0                            | 2    | 0     | 0 | 0                            | 0    | 2     | 0 | 7     | 54               |
| 9:45 AM                               | 1                          | 0    | 0     | 0 | 0                          | 0    | 0     | 0 | 1                            | 0    | 1     | 0 | 0                            | 0    | 2     | 0 | 5     | 55               |
| 9:50 AM                               | 0                          | 0    | 0     | 0 | 0                          | 0    | 0     | 0 | 0                            | 3    | 0     | 0 | 0                            | 0    | 0     | 0 | 3     | 52               |
| 9:55 AM                               | 0                          | 0    | 0     | 0 | 0                          | 0    | 0     | 0 | 0                            | 1    | 0     | 0 | 0                            | 0    | 0     | 0 | 1     | 50               |
| 10:00 AM                              | 0                          | 0    | 0     | 0 | 0                          | 0    | 1     | 0 | 0                            | 0    | 0     | 0 | 0                            | 0    | 0     | 0 | 1     | 49               |
| 10:05 AM                              | 0                          | 0    | 0     | 0 | 0                          | 0    | 2     | 0 | 1                            | 1    | 0     | 0 | 0                            | 0    | 0     | 0 | 4     | 50               |
| 10:10 AM                              | 1                          | 0    | 0     | 0 | 0                          | 0    | 0     | 0 | 0                            | 0    | 0     | 0 | 0                            | 4    | 0     | 0 | 5     | 50               |
| 10:15 AM                              | 0                          | 0    | 0     | 0 | 0                          | 0    | 0     | 0 | 1                            | 0    | 0     | 0 | 0                            | 2    | 1     | 0 | 4     | 49               |
| 10:20 AM                              | 0                          | 0    | 0     | 0 | 0                          | 0    | 0     | 0 | 0                            | 0    | 1     | 0 | 0                            | 1    | 0     | 0 | 2     | 50               |
| 10:25 AM                              | 1                          | 0    | 0     | 0 | 0                          | 0    | 0     | 0 | 0                            | 0    | 0     | 0 | 0                            | 0    | 0     | 0 | 1     | 43               |
| 10:30 AM                              | 0                          | 0    | 0     | 0 | 0                          | 0    | 0     | 0 | 0                            | 2    | 0     | 0 | 0                            | 0    | 0     | 0 | 2     | 39               |
| 10:35 AM                              | 2                          | 0    | 0     | 0 | 0                          | 1    | 2     | 0 | 1                            | 1    | 0     | 0 | 0                            | 0    | 0     | 0 | 7     | 42               |
| 10:40 AM                              | 0                          | 0    | 0     | 0 | 0                          | 0    | 2     | 0 | 1                            | 0    | 1     | 0 | 0                            | 1    | 0     | 0 | 5     | 40               |
| 10:45 AM                              | 0                          | 0    | 0     | 0 | 0                          | 0    | 0     | 0 | 2                            | 0    | 0     | 0 | 0                            | 0    | 0     | 0 | 2     | 37               |
| 10:50 AM                              | 1                          | 0    | 0     | 0 | 0                          | 0    | 0     | 0 | 1                            | 0    | 1     | 0 | 0                            | 0    | 0     | 0 | 3     | 37               |
| 10:55 AM                              | 0                          | 0    | 0     | 0 | 0                          | 0    | 1     | 0 | 1                            | 1    | 0     | 0 | 0                            | 1    | 0     | 0 | 4     | 40               |
| 11:00 AM                              | 1                          | 0    | 0     | 0 | 0                          | 0    | 1     | 0 | 1                            | 1    | 0     | 0 | 0                            | 0    | 0     | 0 | 4     | 43               |
| 11:05 AM                              | 0                          | 0    | 0     | 0 | 0                          | 0    | 0     | 0 | 0                            | 0    | 0     | 0 | 0                            | 1    | 0     | 0 | 1     | 40               |
| 11:10 AM                              | 0                          | 0    | 0     | 0 | 0                          | 0    | 3     | 0 | 0                            | 0    | 0     | 0 | 0                            | 2    | 0     | 0 | 5     | 40               |
| 11:15 AM                              | 3                          | 0    | 0     | 0 | 0                          | 0    | 2     | 0 | 0                            | 1    | 0     | 0 | 0                            | 0    | 0     | 0 | 6     | 42               |
| 11:20 AM                              | 1                          | 0    | 0     | 0 | 0                          | 0    | 0     | 0 | 1                            | 3    | 1     | 0 | 0                            | 2    | 0     | 0 | 8     | 48               |
| 11:25 AM                              | 0                          | 0    | 0     | 0 | 0                          | 0    | 1     | 0 | 1                            | 1    | 1     | 0 | 0                            | 0    | 0     | 0 | 4     | 51               |
| 11:30 AM                              | 0                          | 0    | 1     | 0 | 0                          | 1    | 1     | 0 | 3                            | 0    | 0     | 0 | 0                            | 0    | 0     | 0 | 6     | 55               |
| 11:35 AM                              | 0                          | 0    | 0     | 0 | 0                          | 0    | 0     | 0 | 0                            | 1    | 1     | 0 | 0                            | 1    | 0     | 0 | 3     | 51               |
| 11:40 AM                              | 0                          | 0    | 0     | 0 | 0                          | 0    | 1     | 0 | 1                            | 1    | 0     | 0 | 0                            | 0    | 0     | 0 | 3     | 49               |
| 11:45 AM                              | 0                          | 0    | 0     | 0 | 0                          | 0    | 2     | 0 | 1                            | 1    | 0     | 0 | 0                            | 0    | 0     | 0 | 4     | 51               |
| 11:50 AM                              | 1                          | 0    | 0     | 0 | 0                          | 0    | 2     | 0 | 0                            | 0    | 1     | 0 | 0                            | 0    | 0     | 0 | 4     | 52               |
| 11:55 AM                              | 0                          | 0    | 0     | 0 | 0                          | 0    | 0     | 0 | 1                            | 2    | 0     | 0 | 1                            | 0    | 0     | 0 | 4     | 52               |
| 12:00 PM                              | 1                          | 1    | 0     | 0 | 0                          | 0    | 1     | 0 | 0                            | 1    | 0     | 0 | 0                            | 2    | 0     | 0 | 6     | 54               |
| 12:05 PM                              | 0                          | 0    | 0     | 0 | 0                          | 0    | 2     | 0 | 0                            | 1    | 0     | 0 | 0                            | 1    | 0     | 0 | 4     | 57               |
| 12:10 PM                              | 0                          | 0    | 0     | 0 | 0                          | 0    | 0     | 0 | 1                            | 0    | 0     | 0 | 0                            | 0    | 0     | 0 | 1     | 53               |
| 12:15 PM                              | 0                          | 0    | 0     | 0 | 0                          | 0    | 1     | 0 | 0                            | 0    | 0     | 0 | 0                            | 1    | 0     | 0 | 2     | 49               |
| 12:20 PM                              | 1                          | 0    | 0     | 0 | 0                          | 0    | 1     | 0 | 0                            | 1    | 0     | 0 | 0                            | 0    | 0     | 0 | 3     | 44               |
| 12:25 PM                              | 0                          | 0    | 0     | 0 | 0                          | 0    | 0     | 0 | 1                            | 0    | 1     | 0 | 0                            | 2    | 0     | 0 | 4     | 44               |
| 12:30 PM                              | 0                          | 0    | 0     | 0 | 0                          | 0    | 0     | 0 | 1                            | 0    | 1     | 0 | 0                            | 0    | 0     | 0 | 2     | 40               |
| 12:35 PM                              | 0                          | 0    | 0     | 0 | 0                          | 0    | 0     | 0 | 0                            | 1    | 0     | 0 | 0                            | 0    | 0     | 0 | 1     | 38               |
| 12:40 PM                              | 0                          | 0    | 0     | 0 | 0                          | 0    | 0     | 0 | 0                            | 0    | 0     | 0 | 0                            | 2    | 0     | 0 | 2     | 37               |
| 12:45 PM                              | 0                          | 0    | 0     | 0 | 0                          | 0    | 0     | 0 | 0                            | 1    | 0     | 0 | 0                            | 1    | 0     | 0 | 2     | 35               |
| 12:50 PM                              | 1                          | 0    | 0     | 0 | 0                          | 0    | 0     | 0 | 1                            | 0    | 0     | 0 | 0                            | 3    | 0     | 0 | 5     | 36               |
| 12:55 PM                              | 0                          | 0    | 0     | 0 | 0                          | 0    | 0     | 0 | 0                            | 0    | 1     | 0 | 0                            | 2    | 0     | 0 | 3     | 35               |
| 1:00 PM                               | 0                          | 0    | 0     | 0 | 0                          | 0    | 0     | 0 | 1                            | 0    | 0     | 0 | 0                            | 1    | 0     | 0 | 2     | 31               |
| 1:05 PM                               | 0                          | 0    | 0     | 0 | 0                          | 0    | 0     | 0 | 2                            | 0    | 1     | 0 | 0                            | 0    | 0     | 0 | 3     | 30               |
| 1:10 PM                               | 1                          | 0    | 0     | 0 | 0                          | 0    | 1     | 0 | 0                            | 0    | 2     | 0 | 0                            | 0    | 0     | 0 | 4     | 33               |
| 1:15 PM                               | 0                          | 0    | 0     | 0 | 0                          | 0    | 0     | 0 | 1                            | 0    | 1     | 0 | 0                            | 1    | 0     | 0 | 3     | 34               |
| 1:20 PM                               | 1                          | 0    | 0     | 0 | 0                          | 0    | 0     | 0 | 0                            | 0    | 0     | 0 | 0                            | 1    | 0     | 0 | 2     | 33               |
| 1:25 PM                               | 0                          | 0    | 1     | 0 | 0                          | 0    | 0     | 0 | 1                            | 2    | 0     | 0 | 0                            | 0    | 0     | 0 | 4     | 33               |
| 1:30 PM                               | 0                          | 0    | 0     | 0 | 0                          | 0    | 1     | 0 | 1                            | 1    | 1     | 0 | 0                            | 1    | 0     | 0 | 5     | 36               |
| 1:35 PM                               | 0                          | 0    | 0     | 0 | 0                          | 0    | 1     | 0 | 3                            | 2    | 1     | 0 | 0                            | 1    | 0     | 0 | 8     | 43               |
| 1:40 PM                               | 0                          | 0    | 0     | 0 | 0                          | 0    | 1     | 0 | 1                            | 1    | 0     | 0 | 0                            | 0    | 1     | 0 | 4     | 45               |
| 1:45 PM                               | 1                          | 0    | 0     | 0 | 0                          | 0    | 1     | 0 | 0                            | 1    | 2     | 0 | 2                            | 1    | 0     | 0 | 8     | 51               |
| 1:50 PM                               | 1                          | 1    | 0     | 0 | 1                          | 0    | 1     | 0 | 0                            | 0    | 0     | 0 | 0                            | 1    | 0     | 0 | 5     | 51               |
| 1:55 PM                               | 0                          | 0    | 0     | 0 | 0                          | 0    | 0     | 0 | 0                            | 0    | 0     | 0 | 0                            | 1    | 0     | 0 | 1     | 49               |
| 2:00 PM                               | 0                          | 0    | 0     | 0 | 1                          | 0    | 1     | 0 | 0                            | 1    | 1     | 0 | 0                            | 0    | 0     | 0 | 4     | 51               |
| 2:05 PM                               | 1                          | 0    | 0     | 0 | 0                          | 0    | 0     | 0 | 0                            | 0    | 1     | 0 | 0                            | 0    | 0     | 0 | 2     | 50               |
| 2:10 PM                               | 0                          | 0    | 0     | 0 | 0                          | 0    | 1     | 0 | 1                            | 1    | 1     | 0 | 0                            | 1    | 0     | 0 | 5     | 51               |
| 2:15 PM                               | 0                          | 0    | 0     | 0 | 0                          | 0    | 0     | 0 | 1                            | 1    | 1     | 0 | 0                            | 0    | 0     | 0 | 3     | 51               |
| 2:20 PM                               | 1                          | 0    | 0     | 0 | 0                          | 0    | 0     | 0 | 0                            | 1    | 0     | 0 | 0                            | 1    | 0     | 0 | 3     | 52               |
| 2:25 PM                               | 0                          | 0    | 0     | 0 | 0                          | 0    | 2     | 0 | 1                            | 1    | 0     | 0 | 0                            | 0    | 0     | 0 | 4     | 52               |
| 2:30 PM                               | 0                          | 0    | 0     | 0 | 0                          | 0    | 1     | 0 | 0                            | 0    | 0     | 0 | 0                            | 0    | 0     | 0 | 1     | 48               |
| 2:35 PM                               | 0                          | 0    | 0     | 0 | 0                          | 0    | 0     | 0 | 0                            | 0    | 1     | 0 | 0                            | 1    | 0     | 0 | 2     | 42               |
| 2:40 PM                               | 1                          | 0    | 0     | 0 | 0                          | 0    | 1     | 0 | 1                            | 0    | 0     | 0 | 0                            | 0    | 0     | 0 | 3     | 41               |
| 2:45 PM                               | 0                          | 0    | 0     | 0 | 0                          | 0    | 0     | 0 | 0                            | 1    | 0     | 0 | 0                            | 1    | 0     | 0 | 2     | 35               |
| 2:50 PM                               | 2                          | 0    | 0     | 0 | 0                          | 0    | 0     | 0 | 0                            | 2    | 1     | 0 | 0                            | 0    | 0     | 0 | 5     | 35               |
| 2:55 PM                               | 1                          | 0    | 0     | 0 | 0                          | 0    | 0     | 0 | 0                            | 0    | 0     | 0 | 0                            | 1    | 0     | 0 | 2     | 36               |
| 3:00 PM                               | 0                          | 0    | 0     | 0 | 0                          | 0    | 2     | 0 | 0                            | 0    | 0     | 0 | 0                            | 0    | 0     | 0 | 2     | 34               |
| 3:05 PM                               | 1                          | 0    | 0     | 0 | 0                          | 0    | 1     | 0 | 0                            | 1    | 0     | 0 | 0                            | 0    | 0     | 0 | 3     | 35               |
| 3:10 PM                               | 0                          | 0    | 0     | 0 | 0                          | 0    | 2     | 0 | 0                            | 0    | 0     | 0 | 0                            | 0    | 0     | 0 | 2     | 32               |
| 3:15 PM                               | 0                          | 0    | 0     | 0 | 0                          | 0    | 1     | 0 | 2                            | 0    | 1     | 0 | 0                            | 0    | 0     | 0 | 4     | 33               |
| 3:20 PM                               | 0                          | 0    | 0     | 0 | 0                          | 0    | 0     | 0 | 3                            | 0    | 0     | 0 | 0                            | 0    | 0     | 0 | 3     | 33               |
| 3:25 PM                               | 2                          | 0    | 0     | 0 | 0                          | 0    | 3     | 0 | 2                            | 0    | 0     | 0 | 0                            | 0    | 0     | 0 | 7     | 36               |
| 3:30 PM                               | 1                          | 0    | 0     | 0 | 0                          | 0    | 1     | 0 | 1                            | 1    | 0     | 0 | 0                            | 1    | 0     | 0 | 5     | 40               |
| 3:35 PM                               | 0                          | 0    | 0     | 0 | 0                          | 0    | 0     | 0 | 2                            | 1    | 1     | 0 | 0                            | 0    | 0     | 0 | 4     | 42               |
| 3:40 PM                               | 0                          | 0    | 0     | 0 | 0                          | 0    | 1     | 0 | 1                            | 2    | 2     | 0 | 0                            | 0    | 0     | 0 | 6     | 45               |
| 3:45 PM                               | 1                          | 1    | 1     | 0 | 0                          | 0    | 0     | 0 | 4                            | 0    | 1     | 0 | 1                            | 1    | 0     | 0 | 10    | 53               |
| 3:50 PM                               | 2                          | 0    | 0     | 0 | 0                          | 0    | 1     | 0 | 1                            | 1    | 0     | 0 | 0                            | 0    | 0     | 0 | 5     | 53               |
| 3:55 PM                               | 0                          | 0    | 0     | 0 | 0                          | 0    | 1     | 0 | 0                            | 2    | 2     | 0 | 0                            | 0    | 0     | 0 | 5     | 56               |
| 4:00 PM                               | 0                          | 0    | 0     | 0 | 0                          | 0    | 0     | 0 | 0                            | 4    | 1     | 0 | 0                            | 1    | 0     | 0 | 6     | 60               |
| 4:05 PM                               | 0                          | 0    | 0     | 0 | 0                          | 0    | 0     | 0 | 3                            | 0    | 1     | 0 | 0                            | 0    | 0     | 0 | 4     | 61               |
| 4:10 PM                               | 1                          | 0    | 0     | 0 | 0                          | 0    | 1     | 0 | 0                            | 2    | 1     | 0 | 0                            | 0    | 0     | 0 | 5     | 64               |
| 4:15 PM                               | 1                          | 0    | 0     | 0 | 0                          | 0    | 2     | 0 | 1                            | 0    | 1     | 0 | 0                            | 0    | 0     | 0 | 5     | 65               |
| 4:20 PM                               | 1                          | 0    | 0     | 0 | 0                          | 0    | 0     | 0 | 3                            | 1    | 1     | 0 | 0                            | 0    | 0     | 0 | 6     | 68               |
| 4:25 PM                               | 0                          | 0    | 0     | 0 | 0                          | 0    | 0     | 0 | 1                            | 1    | 0     | 0 | 0                            | 0    | 0     | 0 | 2     | 63               |
| 4:30 PM                               | 2                          | 0    | 0     | 0 | 0                          | 0    | 1     | 0 | 0                            | 0    | 0     | 0 | 0                            | 0    | 0     | 0 | 3     | 61               |

**Attachment B**

| 5-Min Count Period Beginning At | Shea Ridge (Northbound) |      |       |   | Shea Ridge (Southbound) |      |       |   | Rolling Ridge (Eastbound) |      |       |   | Rolling Ridge (Westbound) |      |       |   | Total | Hourly Totals |
|---------------------------------|-------------------------|------|-------|---|-------------------------|------|-------|---|---------------------------|------|-------|---|---------------------------|------|-------|---|-------|---------------|
|                                 | Left                    | Thru | Right | U | Left                    | Thru | Right | U | Left                      | Thru | Right | U | Left                      | Thru | Right | U |       |               |
| 4:35 PM                         | 0                       | 0    | 0     | 0 | 0                       | 0    | 1     | 0 | 1                         | 1    | 1     | 0 | 0                         | 0    | 0     | 0 | 4     | 61            |
| 4:40 PM                         | 0                       | 0    | 0     | 0 | 0                       | 0    | 2     | 0 | 0                         | 3    | 1     | 0 | 0                         | 0    | 0     | 0 | 6     | 61            |
| 4:45 PM                         | 0                       | 0    | 0     | 0 | 0                       | 0    | 0     | 0 | 1                         | 1    | 0     | 0 | 0                         | 1    | 2     | 0 | 5     | 56            |
| 4:50 PM                         | 0                       | 0    | 0     | 0 | 0                       | 0    | 2     | 0 | 0                         | 0    | 1     | 0 | 0                         | 1    | 0     | 0 | 4     | 55            |
| 4:55 PM                         | 0                       | 0    | 0     | 0 | 0                       | 0    | 1     | 0 | 3                         | 0    | 0     | 0 | 0                         | 0    | 0     | 0 | 4     | 54            |
| 5:00 PM                         | 0                       | 0    | 0     | 0 | 0                       | 0    | 1     | 0 | 1                         | 1    | 0     | 0 | 0                         | 0    | 0     | 0 | 3     | 51            |
| 5:05 PM                         | 0                       | 0    | 0     | 0 | 0                       | 0    | 1     | 0 | 2                         | 1    | 0     | 0 | 0                         | 1    | 0     | 0 | 5     | 52            |
| 5:10 PM                         | 0                       | 0    | 0     | 0 | 0                       | 0    | 1     | 0 | 1                         | 0    | 0     | 0 | 1                         | 0    | 0     | 0 | 3     | 50            |
| 5:15 PM                         | 1                       | 1    | 0     | 0 | 0                       | 0    | 1     | 0 | 2                         | 0    | 2     | 0 | 0                         | 0    | 0     | 0 | 7     | 52            |
| 5:20 PM                         | 0                       | 0    | 0     | 0 | 0                       | 0    | 5     | 0 | 0                         | 0    | 1     | 0 | 0                         | 0    | 0     | 0 | 6     | 52            |
| 5:25 PM                         | 0                       | 0    | 0     | 0 | 0                       | 0    | 0     | 0 | 1                         | 2    | 1     | 0 | 0                         | 2    | 0     | 0 | 6     | 56            |
| 5:30 PM                         | 0                       | 0    | 0     | 0 | 0                       | 0    | 1     | 0 | 2                         | 4    | 0     | 0 | 0                         | 1    | 0     | 0 | 8     | 61            |
| 5:35 PM                         | 0                       | 0    | 0     | 0 | 0                       | 0    | 1     | 0 | 3                         | 1    | 0     | 0 | 0                         | 0    | 0     | 0 | 5     | 62            |
| 5:40 PM                         | 0                       | 0    | 0     | 0 | 1                       | 0    | 2     | 0 | 1                         | 1    | 0     | 0 | 0                         | 0    | 0     | 0 | 5     | 61            |
| 5:45 PM                         | 2                       | 0    | 0     | 0 | 0                       | 0    | 3     | 0 | 1                         | 0    | 0     | 0 | 0                         | 1    | 0     | 0 | 7     | 63            |
| 5:50 PM                         | 0                       | 0    | 0     | 0 | 0                       | 0    | 1     | 0 | 1                         | 0    | 1     | 0 | 0                         | 0    | 0     | 0 | 3     | 62            |
| 5:55 PM                         | 0                       | 0    | 0     | 0 | 0                       | 0    | 0     | 0 | 1                         | 1    | 2     | 0 | 0                         | 0    | 0     | 0 | 4     | 62            |
| 6:00 PM                         | 1                       | 0    | 0     | 0 | 0                       | 0    | 1     | 0 | 0                         | 0    | 0     | 0 | 0                         | 1    | 0     | 0 | 3     | 62            |
| 6:05 PM                         | 0                       | 0    | 0     | 0 | 0                       | 0    | 1     | 0 | 1                         | 3    | 1     | 0 | 0                         | 2    | 0     | 0 | 8     | 65            |
| 6:10 PM                         | 1                       | 0    | 0     | 0 | 0                       | 0    | 0     | 0 | 2                         | 0    | 2     | 0 | 0                         | 1    | 0     | 0 | 6     | 68            |
| 6:15 PM                         | 0                       | 0    | 0     | 0 | 0                       | 0    | 0     | 0 | 2                         | 0    | 0     | 0 | 0                         | 1    | 0     | 0 | 3     | 64            |
| 6:20 PM                         | 0                       | 0    | 0     | 0 | 0                       | 0    | 1     | 0 | 1                         | 0    | 0     | 0 | 0                         | 0    | 0     | 0 | 2     | 60            |
| 6:25 PM                         | 0                       | 0    | 0     | 0 | 0                       | 0    | 0     | 0 | 1                         | 0    | 1     | 0 | 0                         | 1    | 0     | 0 | 3     | 57            |
| 6:30 PM                         | 1                       | 0    | 0     | 0 | 0                       | 0    | 1     | 0 | 1                         | 1    | 3     | 0 | 0                         | 0    | 0     | 0 | 7     | 56            |
| 6:35 PM                         | 1                       | 0    | 0     | 0 | 0                       | 0    | 0     | 0 | 1                         | 1    | 0     | 0 | 0                         | 1    | 0     | 0 | 4     | 55            |
| 6:40 PM                         | 0                       | 0    | 0     | 0 | 0                       | 0    | 2     | 0 | 0                         | 1    | 0     | 0 | 0                         | 2    | 0     | 0 | 5     | 55            |
| 6:45 PM                         | 0                       | 0    | 0     | 0 | 0                       | 0    | 0     | 0 | 1                         | 1    | 0     | 0 | 0                         | 0    | 0     | 0 | 2     | 50            |
| 6:50 PM                         | 1                       | 0    | 0     | 0 | 0                       | 0    | 1     | 0 | 0                         | 1    | 0     | 0 | 0                         | 1    | 0     | 0 | 4     | 51            |
| 6:55 PM                         | 0                       | 0    | 0     | 0 | 0                       | 0    | 0     | 0 | 1                         | 1    | 0     | 0 | 0                         | 0    | 0     | 0 | 2     | 49            |
| 7:00 PM                         | 2                       | 0    | 0     | 0 | 0                       | 0    | 3     | 0 | 2                         | 1    | 1     | 0 | 0                         | 1    | 0     | 0 | 10    | 56            |
| 7:05 PM                         | 1                       | 0    | 0     | 0 | 0                       | 0    | 0     | 0 | 2                         | 3    | 0     | 0 | 0                         | 1    | 0     | 0 | 7     | 55            |
| 7:10 PM                         | 1                       | 0    | 0     | 0 | 0                       | 1    | 2     | 0 | 2                         | 2    | 1     | 0 | 0                         | 2    | 0     | 0 | 11    | 60            |
| 7:15 PM                         | 0                       | 0    | 0     | 0 | 0                       | 0    | 0     | 0 | 0                         | 0    | 1     | 0 | 0                         | 0    | 0     | 0 | 1     | 58            |
| 7:20 PM                         | 0                       | 0    | 0     | 0 | 0                       | 0    | 0     | 0 | 2                         | 0    | 1     | 0 | 0                         | 0    | 0     | 0 | 3     | 59            |
| 7:25 PM                         | 0                       | 0    | 0     | 0 | 0                       | 0    | 0     | 0 | 0                         | 0    | 0     | 0 | 0                         | 1    | 0     | 0 | 1     | 57            |
| 7:30 PM                         | 1                       | 0    | 0     | 0 | 0                       | 0    | 0     | 0 | 0                         | 0    | 0     | 0 | 0                         | 0    | 0     | 0 | 1     | 51            |
| 7:35 PM                         | 1                       | 0    | 0     | 0 | 0                       | 0    | 0     | 0 | 1                         | 0    | 0     | 0 | 0                         | 1    | 0     | 0 | 3     | 50            |
| 7:40 PM                         | 0                       | 0    | 0     | 0 | 0                       | 0    | 1     | 0 | 0                         | 0    | 0     | 0 | 0                         | 0    | 0     | 0 | 1     | 46            |
| 7:45 PM                         | 0                       | 0    | 0     | 0 | 0                       | 0    | 0     | 0 | 3                         | 1    | 1     | 0 | 0                         | 0    | 0     | 0 | 5     | 49            |
| 7:50 PM                         | 0                       | 0    | 0     | 0 | 0                       | 0    | 1     | 0 | 1                         | 0    | 1     | 0 | 0                         | 0    | 0     | 0 | 3     | 48            |
| 7:55 PM                         | 0                       | 0    | 0     | 0 | 0                       | 0    | 1     | 0 | 0                         | 1    | 0     | 0 | 0                         | 0    | 0     | 0 | 2     | 48            |
| 8:00 PM                         | 0                       | 0    | 0     | 0 | 0                       | 0    | 0     | 0 | 3                         | 3    | 0     | 0 | 0                         | 0    | 0     | 0 | 6     | 44            |
| 8:05 PM                         | 0                       | 0    | 0     | 0 | 0                       | 0    | 0     | 0 | 2                         | 1    | 0     | 0 | 0                         | 0    | 0     | 0 | 3     | 40            |
| 8:10 PM                         | 0                       | 0    | 0     | 0 | 0                       | 0    | 4     | 0 | 1                         | 2    | 0     | 0 | 0                         | 0    | 0     | 0 | 7     | 36            |
| 8:15 PM                         | 0                       | 0    | 0     | 0 | 0                       | 0    | 0     | 0 | 1                         | 0    | 1     | 0 | 0                         | 0    | 0     | 0 | 2     | 37            |
| 8:20 PM                         | 1                       | 0    | 0     | 0 | 0                       | 0    | 0     | 0 | 1                         | 1    | 1     | 0 | 0                         | 0    | 0     | 0 | 4     | 38            |
| 8:25 PM                         | 0                       | 0    | 0     | 0 | 0                       | 0    | 0     | 0 | 1                         | 1    | 0     | 0 | 0                         | 0    | 0     | 0 | 2     | 39            |
| 8:30 PM                         | 1                       | 0    | 0     | 0 | 0                       | 0    | 0     | 0 | 0                         | 1    | 1     | 0 | 0                         | 1    | 0     | 0 | 4     | 42            |
| 8:35 PM                         | 1                       | 0    | 0     | 0 | 0                       | 0    | 0     | 0 | 1                         | 0    | 0     | 0 | 0                         | 0    | 0     | 0 | 2     | 41            |
| 8:40 PM                         | 0                       | 0    | 0     | 0 | 0                       | 0    | 0     | 0 | 0                         | 0    | 1     | 0 | 0                         | 1    | 0     | 0 | 2     | 42            |
| 8:45 PM                         | 0                       | 0    | 0     | 0 | 0                       | 0    | 1     | 0 | 3                         | 0    | 0     | 0 | 0                         | 1    | 0     | 0 | 5     | 42            |
| 8:50 PM                         | 1                       | 0    | 0     | 0 | 0                       | 0    | 0     | 0 | 0                         | 1    | 0     | 0 | 0                         | 0    | 0     | 0 | 2     | 41            |
| 8:55 PM                         | 0                       | 0    | 0     | 0 | 0                       | 0    | 0     | 0 | 0                         | 1    | 0     | 0 | 0                         | 0    | 0     | 0 | 1     | 40            |
| 9:00 PM                         | 0                       | 0    | 0     | 0 | 0                       | 0    | 0     | 0 | 0                         | 0    | 0     | 0 | 0                         | 0    | 0     | 0 | 0     | 34            |
| 9:05 PM                         | 0                       | 0    | 0     | 0 | 0                       | 0    | 1     | 0 | 2                         | 0    | 1     | 0 | 0                         | 0    | 0     | 0 | 4     | 35            |
| 9:10 PM                         | 0                       | 0    | 0     | 0 | 0                       | 0    | 0     | 0 | 0                         | 1    | 2     | 0 | 0                         | 0    | 0     | 0 | 3     | 31            |
| 9:15 PM                         | 0                       | 0    | 0     | 0 | 0                       | 0    | 0     | 0 | 0                         | 1    | 0     | 0 | 0                         | 0    | 0     | 0 | 1     | 30            |
| 9:20 PM                         | 1                       | 0    | 0     | 0 | 0                       | 0    | 0     | 0 | 1                         | 1    | 1     | 0 | 0                         | 1    | 0     | 0 | 5     | 31            |
| 9:25 PM                         | 1                       | 0    | 0     | 0 | 0                       | 0    | 0     | 0 | 1                         | 0    | 0     | 0 | 0                         | 0    | 0     | 0 | 2     | 31            |
| 9:30 PM                         | 0                       | 0    | 0     | 0 | 0                       | 0    | 0     | 0 | 0                         | 0    | 0     | 0 | 0                         | 0    | 0     | 0 | 0     | 27            |
| 9:35 PM                         | 0                       | 0    | 0     | 0 | 0                       | 0    | 0     | 0 | 2                         | 0    | 0     | 0 | 0                         | 0    | 0     | 0 | 2     | 27            |
| 9:40 PM                         | 0                       | 0    | 0     | 0 | 0                       | 0    | 0     | 0 | 0                         | 0    | 0     | 0 | 0                         | 0    | 0     | 0 | 0     | 25            |
| 9:45 PM                         | 0                       | 0    | 0     | 0 | 0                       | 0    | 0     | 0 | 0                         | 2    | 1     | 0 | 0                         | 0    | 0     | 0 | 3     | 23            |
| 9:50 PM                         | 0                       | 0    | 0     | 0 | 0                       | 0    | 0     | 0 | 1                         | 1    | 0     | 0 | 0                         | 0    | 0     | 0 | 2     | 23            |
| 9:55 PM                         | 0                       | 0    | 0     | 0 | 0                       | 0    | 0     | 0 | 0                         | 0    | 0     | 0 | 0                         | 0    | 0     | 0 | 0     | 22            |
| Peak 15-Min Flowrates           | Northbound              |      |       |   | Southbound              |      |       |   | Eastbound                 |      |       |   | Westbound                 |      |       |   | Total |               |
|                                 | Left                    | Thru | Right | U | Left                    | Thru | Right | U | Left                      | Thru | Right | U | Left                      | Thru | Right | U |       |               |
| All Vehicles                    | 8                       | 0    | 4     | 0 | 0                       | 4    | 20    | 0 | 4                         | 8    | 16    | 0 | 0                         | 28   | 0     | 0 | 92    |               |
| Heavy Trucks                    | 0                       | 0    | 4     |   | 0                       | 4    | 0     |   | 0                         | 0    | 0     |   | 0                         | 0    | 0     |   | 8     |               |
| Buses                           |                         |      |       |   |                         |      |       |   |                           |      |       |   |                           |      |       |   |       |               |
| Pedestrians                     |                         | 0    |       |   |                         | 4    |       |   |                           | 0    |       |   |                           | 0    |       |   | 4     |               |
| Bicycles                        | 0                       | 0    | 0     |   | 0                       | 0    | 0     |   | 0                         | 0    | 0     |   | 0                         | 4    | 0     |   | 4     |               |
| Scoters                         |                         |      |       |   |                         |      |       |   |                           |      |       |   |                           |      |       |   |       |               |
| <i>Comments:</i>                |                         |      |       |   |                         |      |       |   |                           |      |       |   |                           |      |       |   |       |               |

LOCATION: Blakemore Dr -- Kempton Ln  
 CITY/STATE: Ladera Ranch, CA

QC JOB #: 16966457  
 DATE: Wed, Apr 16 2025

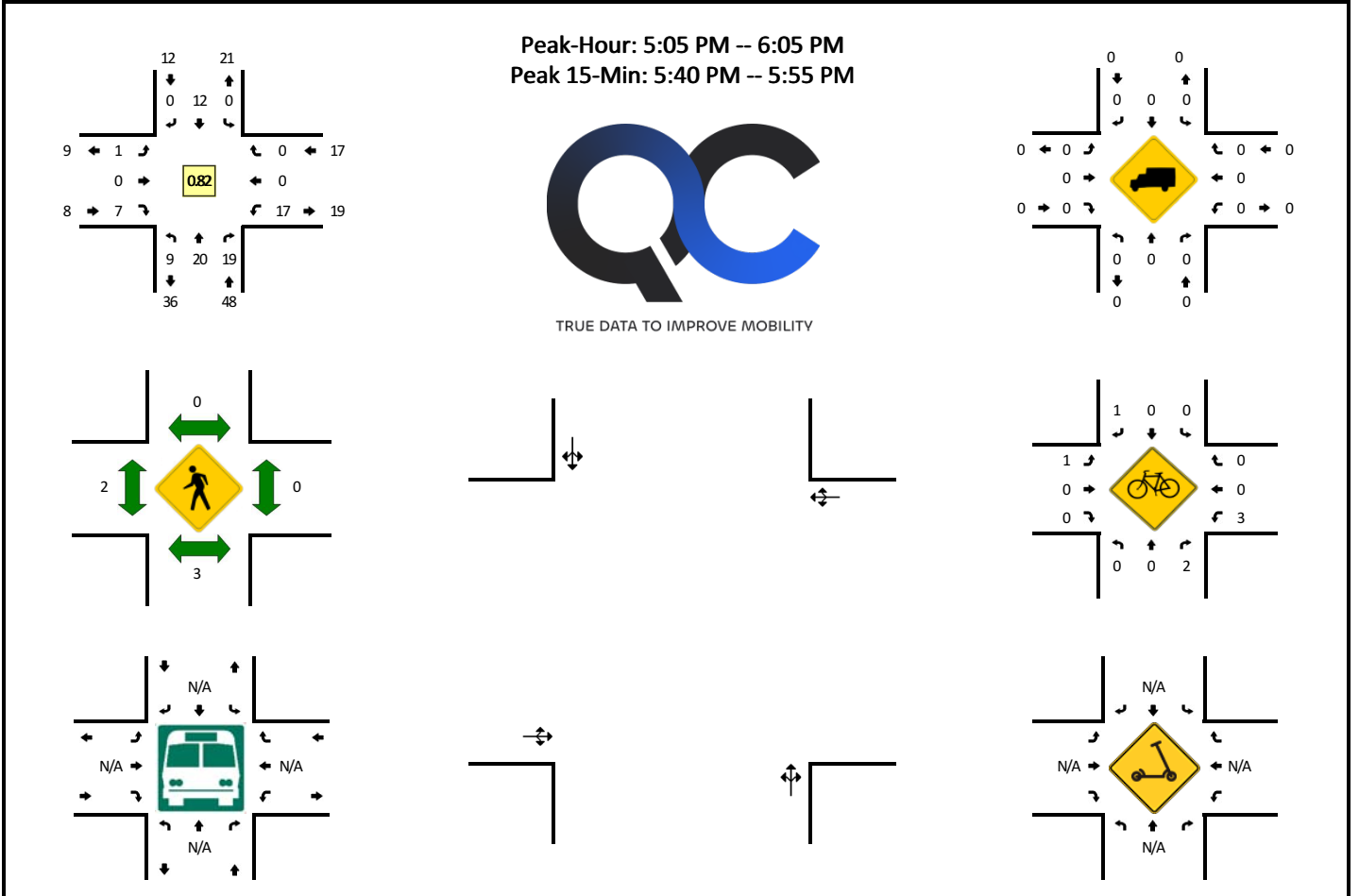

| 5-Min Count Period Beginning At | Blakemore Dr (Northbound) |      |       |   | Blakemore Dr (Southbound) |      |       |   | Kempton Ln (Eastbound) |      |       |   | Kempton Ln (Westbound) |      |       |   | Total | Hourly Totals |
|---------------------------------|---------------------------|------|-------|---|---------------------------|------|-------|---|------------------------|------|-------|---|------------------------|------|-------|---|-------|---------------|
|                                 | Left                      | Thru | Right | U | Left                      | Thru | Right | U | Left                   | Thru | Right | U | Left                   | Thru | Right | U |       |               |
| 6:00 AM                         | 0                         | 0    | 0     | 0 | 0                         | 1    | 0     | 0 | 0                      | 0    | 0     | 0 | 1                      | 0    | 0     | 0 | 2     |               |
| 6:05 AM                         | 0                         | 0    | 0     | 0 | 0                         | 1    | 0     | 0 | 0                      | 0    | 0     | 0 | 0                      | 0    | 0     | 0 | 1     |               |
| 6:10 AM                         | 0                         | 0    | 0     | 0 | 0                         | 0    | 0     | 0 | 0                      | 0    | 0     | 1 | 0                      | 0    | 0     | 0 | 1     |               |
| 6:15 AM                         | 0                         | 1    | 0     | 0 | 0                         | 0    | 1     | 0 | 0                      | 0    | 0     | 0 | 1                      | 0    | 0     | 0 | 3     |               |
| 6:20 AM                         | 0                         | 0    | 0     | 0 | 0                         | 0    | 0     | 0 | 0                      | 0    | 0     | 0 | 1                      | 0    | 0     | 0 | 1     |               |
| 6:25 AM                         | 0                         | 0    | 1     | 0 | 0                         | 2    | 0     | 0 | 0                      | 0    | 0     | 0 | 0                      | 0    | 0     | 0 | 3     |               |
| 6:30 AM                         | 0                         | 0    | 0     | 0 | 0                         | 0    | 0     | 0 | 0                      | 0    | 0     | 0 | 0                      | 0    | 0     | 0 | 0     |               |
| 6:35 AM                         | 0                         | 0    | 1     | 0 | 0                         | 0    | 0     | 0 | 0                      | 0    | 0     | 0 | 0                      | 0    | 1     | 0 | 2     |               |
| 6:40 AM                         | 0                         | 0    | 0     | 0 | 0                         | 2    | 0     | 0 | 0                      | 0    | 0     | 0 | 0                      | 0    | 0     | 0 | 2     |               |
| 6:45 AM                         | 0                         | 0    | 0     | 0 | 0                         | 0    | 0     | 0 | 0                      | 0    | 0     | 0 | 0                      | 0    | 0     | 0 | 0     |               |
| 6:50 AM                         | 0                         | 0    | 0     | 0 | 0                         | 0    | 0     | 0 | 0                      | 0    | 0     | 1 | 1                      | 0    | 0     | 0 | 2     |               |
| 6:55 AM                         | 0                         | 0    | 1     | 0 | 0                         | 0    | 0     | 0 | 0                      | 0    | 0     | 0 | 1                      | 0    | 0     | 0 | 2     | 19            |
| 7:00 AM                         | 0                         | 0    | 1     | 0 | 0                         | 0    | 0     | 0 | 0                      | 0    | 0     | 1 | 3                      | 0    | 0     | 0 | 5     | 22            |
| 7:05 AM                         | 1                         | 0    | 0     | 0 | 0                         | 0    | 0     | 0 | 0                      | 0    | 0     | 1 | 1                      | 0    | 0     | 0 | 3     | 24            |
| 7:10 AM                         | 0                         | 0    | 2     | 0 | 0                         | 1    | 0     | 0 | 0                      | 0    | 0     | 0 | 2                      | 0    | 0     | 0 | 5     | 28            |
| 7:15 AM                         | 0                         | 0    | 2     | 0 | 0                         | 1    | 0     | 0 | 0                      | 0    | 0     | 1 | 1                      | 0    | 0     | 0 | 5     | 30            |
| 7:20 AM                         | 1                         | 0    | 2     | 0 | 0                         | 2    | 0     | 0 | 0                      | 0    | 0     | 1 | 3                      | 0    | 0     | 0 | 9     | 38            |
| 7:25 AM                         | 0                         | 0    | 0     | 0 | 0                         | 1    | 0     | 0 | 0                      | 0    | 0     | 0 | 0                      | 0    | 0     | 0 | 1     | 36            |
| 7:30 AM                         | 0                         | 0    | 1     | 0 | 0                         | 1    | 0     | 0 | 0                      | 0    | 0     | 1 | 1                      | 0    | 0     | 0 | 4     | 40            |
| 7:35 AM                         | 0                         | 0    | 0     | 0 | 0                         | 3    | 0     | 0 | 0                      | 0    | 0     | 2 | 1                      | 0    | 0     | 0 | 6     | 44            |
| 7:40 AM                         | 0                         | 1    | 0     | 0 | 0                         | 1    | 0     | 0 | 0                      | 0    | 0     | 2 | 1                      | 0    | 0     | 0 | 5     | 47            |
| 7:45 AM                         | 0                         | 0    | 0     | 0 | 0                         | 2    | 0     | 0 | 0                      | 0    | 0     | 3 | 3                      | 0    | 0     | 0 | 8     | 55            |
| 7:50 AM                         | 1                         | 1    | 2     | 1 | 0                         | 1    | 0     | 0 | 0                      | 0    | 0     | 0 | 4                      | 0    | 0     | 0 | 10    | 63            |
| 7:55 AM                         | 1                         | 1    | 0     | 0 | 0                         | 2    | 0     | 0 | 0                      | 0    | 0     | 0 | 1                      | 0    | 0     | 0 | 5     | 66            |
| 8:00 AM                         | 2                         | 1    | 2     | 0 | 0                         | 1    | 0     | 0 | 0                      | 0    | 0     | 1 | 3                      | 0    | 0     | 0 | 10    | 71            |
| 8:05 AM                         | 0                         | 1    | 1     | 0 | 0                         | 2    | 0     | 0 | 0                      | 0    | 0     | 0 | 1                      | 0    | 0     | 0 | 5     | 73            |
| 8:10 AM                         | 0                         | 0    | 0     | 0 | 0                         | 0    | 0     | 0 | 0                      | 0    | 0     | 0 | 5                      | 0    | 0     | 0 | 5     | 73            |
| 8:15 AM                         | 0                         | 1    | 1     | 0 | 0                         | 0    | 0     | 0 | 0                      | 0    | 0     | 0 | 5                      | 0    | 0     | 0 | 7     | 75            |
| 8:20 AM                         | 1                         | 0    | 1     | 0 | 0                         | 0    | 0     | 0 | 0                      | 0    | 0     | 0 | 0                      | 0    | 0     | 0 | 2     | 68            |
| 8:25 AM                         | 0                         | 0    | 0     | 0 | 0                         | 0    | 0     | 0 | 0                      | 0    | 0     | 0 | 3                      | 0    | 0     | 0 | 3     | 70            |
| 8:30 AM                         | 1                         | 1    | 0     | 0 | 0                         | 1    | 0     | 0 | 0                      | 0    | 0     | 0 | 2                      | 0    | 0     | 0 | 5     | 71            |
| 8:35 AM                         | 0                         | 0    | 2     | 0 | 0                         | 1    | 0     | 0 | 0                      | 0    | 0     | 1 | 1                      | 0    | 0     | 0 | 5     | 70            |
| 8:40 AM                         | 0                         | 1    | 1     | 0 | 0                         | 1    | 0     | 0 | 0                      | 0    | 0     | 2 | 1                      | 0    | 0     | 0 | 6     | 71            |
| 8:45 AM                         | 0                         | 0    | 1     | 0 | 0                         | 0    | 0     | 0 | 0                      | 0    | 0     | 1 | 0                      | 0    | 0     | 0 | 2     | 65            |
| 8:50 AM                         | 0                         | 0    | 2     | 0 | 0                         | 2    | 0     | 0 | 0                      | 0    | 0     | 0 | 0                      | 0    | 0     | 0 | 4     | 59            |
| 8:55 AM                         | 2                         | 0    | 1     | 0 | 0                         | 0    | 0     | 0 | 0                      | 0    | 0     | 0 | 0                      | 0    | 1     | 0 | 4     | 58            |
| 9:00 AM                         | 0                         | 0    | 0     | 0 | 0                         | 0    | 0     | 0 | 0                      | 0    | 0     | 2 | 0                      | 0    | 0     | 0 | 2     | 50            |
| 9:05 AM                         | 0                         | 0    | 1     | 0 | 0                         | 1    | 1     | 0 | 0                      | 0    | 0     | 1 | 1                      | 0    | 0     | 0 | 5     | 50            |

**Attachment B**

| 5-Min Count Period Beginning At | Blakemore Dr (Northbound) |      |       |   | Blakemore Dr (Southbound) |      |       |   | Kempton Ln (Eastbound) |      |       |   | Kempton Ln (Westbound) |      |       |   | Total | Hourly Totals |
|---------------------------------|---------------------------|------|-------|---|---------------------------|------|-------|---|------------------------|------|-------|---|------------------------|------|-------|---|-------|---------------|
|                                 | Left                      | Thru | Right | U | Left                      | Thru | Right | U | Left                   | Thru | Right | U | Left                   | Thru | Right | U |       |               |
| 9:10 AM                         | 1                         | 0    | 0     | 0 | 0                         | 0    | 0     | 0 | 0                      | 0    | 1     | 0 | 1                      | 0    | 0     | 0 | 3     | 48            |
| 9:15 AM                         | 0                         | 1    | 0     | 0 | 0                         | 1    | 0     | 0 | 0                      | 0    | 1     | 0 | 2                      | 0    | 0     | 0 | 5     | 46            |
| 9:20 AM                         | 1                         | 1    | 0     | 0 | 0                         | 0    | 0     | 0 | 0                      | 0    | 1     | 0 | 1                      | 0    | 0     | 0 | 4     | 48            |
| 9:25 AM                         | 1                         | 1    | 0     | 0 | 0                         | 1    | 0     | 0 | 0                      | 0    | 0     | 0 | 0                      | 0    | 0     | 0 | 3     | 48            |
| 9:30 AM                         | 0                         | 0    | 2     | 0 | 0                         | 0    | 0     | 0 | 0                      | 0    | 0     | 0 | 0                      | 0    | 0     | 0 | 2     | 45            |
| 9:35 AM                         | 0                         | 1    | 1     | 0 | 0                         | 0    | 0     | 0 | 0                      | 0    | 1     | 0 | 3                      | 0    | 0     | 0 | 6     | 46            |
| 9:40 AM                         | 0                         | 1    | 1     | 0 | 0                         | 3    | 0     | 0 | 0                      | 0    | 0     | 0 | 4                      | 0    | 1     | 0 | 10    | 50            |
| 9:45 AM                         | 1                         | 0    | 2     | 0 | 0                         | 0    | 0     | 0 | 0                      | 0    | 1     | 0 | 0                      | 0    | 0     | 0 | 4     | 52            |
| 9:50 AM                         | 0                         | 0    | 0     | 0 | 0                         | 2    | 1     | 0 | 0                      | 0    | 0     | 0 | 0                      | 0    | 0     | 0 | 3     | 51            |
| 9:55 AM                         | 0                         | 0    | 0     | 0 | 0                         | 1    | 0     | 0 | 0                      | 0    | 1     | 0 | 0                      | 0    | 0     | 0 | 2     | 49            |
| 10:00 AM                        | 0                         | 0    | 0     | 0 | 0                         | 1    | 0     | 0 | 0                      | 0    | 0     | 2 | 2                      | 0    | 0     | 0 | 5     | 52            |
| 10:05 AM                        | 0                         | 0    | 2     | 0 | 0                         | 1    | 0     | 0 | 0                      | 0    | 1     | 0 | 0                      | 0    | 0     | 0 | 4     | 51            |
| 10:10 AM                        | 0                         | 0    | 1     | 0 | 0                         | 0    | 0     | 0 | 0                      | 0    | 0     | 0 | 2                      | 0    | 0     | 0 | 3     | 51            |
| 10:15 AM                        | 0                         | 2    | 0     | 0 | 0                         | 0    | 0     | 0 | 0                      | 0    | 0     | 0 | 3                      | 0    | 0     | 0 | 5     | 51            |
| 10:20 AM                        | 0                         | 0    | 4     | 0 | 0                         | 0    | 0     | 0 | 0                      | 0    | 2     | 0 | 0                      | 0    | 0     | 0 | 6     | 53            |
| 10:25 AM                        | 0                         | 0    | 1     | 0 | 0                         | 1    | 0     | 0 | 0                      | 0    | 0     | 0 | 1                      | 0    | 0     | 0 | 3     | 53            |
| 10:30 AM                        | 0                         | 0    | 1     | 0 | 0                         | 0    | 0     | 0 | 0                      | 0    | 0     | 0 | 3                      | 0    | 0     | 0 | 4     | 55            |
| 10:35 AM                        | 0                         | 0    | 0     | 0 | 0                         | 0    | 0     | 0 | 0                      | 0    | 0     | 0 | 0                      | 0    | 0     | 0 | 0     | 49            |
| 10:40 AM                        | 1                         | 0    | 1     | 0 | 0                         | 0    | 0     | 0 | 0                      | 0    | 0     | 0 | 0                      | 0    | 0     | 0 | 2     | 41            |
| 10:45 AM                        | 0                         | 1    | 1     | 0 | 0                         | 0    | 0     | 0 | 0                      | 0    | 0     | 0 | 1                      | 0    | 0     | 0 | 3     | 40            |
| 10:50 AM                        | 2                         | 0    | 1     | 0 | 0                         | 0    | 0     | 0 | 0                      | 0    | 1     | 0 | 0                      | 0    | 0     | 0 | 4     | 41            |
| 10:55 AM                        | 4                         | 1    | 0     | 0 | 0                         | 3    | 0     | 0 | 0                      | 0    | 1     | 0 | 0                      | 0    | 0     | 0 | 9     | 48            |
| 11:00 AM                        | 0                         | 0    | 0     | 0 | 0                         | 1    | 0     | 0 | 0                      | 0    | 1     | 0 | 1                      | 0    | 0     | 0 | 3     | 46            |
| 11:05 AM                        | 0                         | 1    | 0     | 0 | 0                         | 0    | 0     | 0 | 0                      | 0    | 2     | 0 | 2                      | 0    | 0     | 0 | 5     | 47            |
| 11:10 AM                        | 0                         | 0    | 1     | 0 | 0                         | 1    | 0     | 0 | 0                      | 0    | 1     | 0 | 5                      | 0    | 0     | 0 | 8     | 52            |
| 11:15 AM                        | 0                         | 1    | 0     | 0 | 0                         | 0    | 0     | 0 | 0                      | 0    | 1     | 0 | 4                      | 0    | 0     | 0 | 6     | 53            |
| 11:20 AM                        | 0                         | 0    | 2     | 0 | 0                         | 0    | 0     | 0 | 0                      | 0    | 0     | 0 | 1                      | 0    | 0     | 0 | 3     | 50            |
| 11:25 AM                        | 0                         | 0    | 1     | 0 | 0                         | 1    | 0     | 0 | 0                      | 0    | 0     | 0 | 0                      | 0    | 0     | 0 | 2     | 49            |
| 11:30 AM                        | 1                         | 1    | 0     | 0 | 0                         | 0    | 0     | 0 | 0                      | 0    | 0     | 0 | 0                      | 0    | 0     | 0 | 2     | 47            |
| 11:35 AM                        | 0                         | 0    | 0     | 0 | 0                         | 0    | 0     | 0 | 0                      | 0    | 0     | 0 | 1                      | 0    | 0     | 0 | 1     | 48            |
| 11:40 AM                        | 0                         | 1    | 2     | 0 | 0                         | 1    | 0     | 0 | 0                      | 0    | 1     | 0 | 0                      | 0    | 0     | 0 | 5     | 51            |
| 11:45 AM                        | 0                         | 0    | 1     | 0 | 0                         | 1    | 0     | 0 | 0                      | 0    | 1     | 0 | 0                      | 0    | 0     | 0 | 3     | 51            |
| 11:50 AM                        | 0                         | 0    | 1     | 0 | 0                         | 0    | 0     | 0 | 0                      | 0    | 1     | 0 | 1                      | 0    | 0     | 0 | 3     | 50            |
| 11:55 AM                        | 0                         | 5    | 0     | 0 | 0                         | 1    | 0     | 0 | 0                      | 0    | 0     | 0 | 2                      | 0    | 0     | 0 | 8     | 49            |
| 12:00 PM                        | 2                         | 1    | 3     | 0 | 0                         | 0    | 0     | 0 | 0                      | 0    | 0     | 0 | 0                      | 0    | 0     | 0 | 6     | 52            |
| 12:05 PM                        | 0                         | 1    | 0     | 0 | 0                         | 0    | 0     | 0 | 0                      | 1    | 1     | 0 | 2                      | 0    | 0     | 0 | 5     | 52            |
| 12:10 PM                        | 0                         | 1    | 1     | 0 | 0                         | 1    | 0     | 0 | 0                      | 0    | 0     | 0 | 1                      | 0    | 0     | 0 | 4     | 48            |
| 12:15 PM                        | 1                         | 0    | 0     | 0 | 0                         | 0    | 0     | 0 | 0                      | 0    | 0     | 0 | 1                      | 0    | 1     | 0 | 3     | 45            |
| 12:20 PM                        | 0                         | 0    | 0     | 0 | 0                         | 0    | 0     | 0 | 0                      | 0    | 0     | 0 | 2                      | 0    | 0     | 0 | 2     | 44            |
| 12:25 PM                        | 0                         | 0    | 1     | 0 | 0                         | 1    | 0     | 0 | 0                      | 0    | 0     | 0 | 0                      | 0    | 0     | 0 | 2     | 44            |
| 12:30 PM                        | 0                         | 0    | 2     | 0 | 0                         | 1    | 0     | 0 | 0                      | 0    | 1     | 0 | 1                      | 0    | 0     | 0 | 5     | 47            |
| 12:35 PM                        | 1                         | 2    | 4     | 0 | 0                         | 2    | 0     | 0 | 0                      | 0    | 1     | 0 | 2                      | 0    | 0     | 0 | 12    | 58            |
| 12:40 PM                        | 1                         | 0    | 0     | 0 | 0                         | 0    | 0     | 0 | 0                      | 0    | 2     | 0 | 1                      | 0    | 0     | 0 | 4     | 57            |
| 12:45 PM                        | 2                         | 0    | 0     | 0 | 0                         | 2    | 0     | 0 | 0                      | 0    | 1     | 0 | 0                      | 0    | 0     | 0 | 5     | 59            |
| 12:50 PM                        | 1                         | 0    | 0     | 0 | 0                         | 0    | 0     | 0 | 0                      | 0    | 0     | 0 | 1                      | 0    | 0     | 0 | 2     | 58            |
| 12:55 PM                        | 0                         | 1    | 3     | 0 | 0                         | 0    | 0     | 0 | 0                      | 0    | 0     | 0 | 0                      | 0    | 0     | 0 | 4     | 54            |
| 1:00 PM                         | 2                         | 0    | 1     | 0 | 0                         | 2    | 0     | 0 | 0                      | 0    | 2     | 0 | 1                      | 0    | 0     | 0 | 8     | 56            |
| 1:05 PM                         | 2                         | 0    | 1     | 0 | 0                         | 1    | 0     | 0 | 0                      | 0    | 0     | 0 | 1                      | 0    | 0     | 0 | 5     | 56            |
| 1:10 PM                         | 2                         | 0    | 1     | 0 | 0                         | 1    | 0     | 0 | 0                      | 0    | 1     | 0 | 1                      | 0    | 0     | 0 | 6     | 58            |
| 1:15 PM                         | 0                         | 0    | 0     | 0 | 0                         | 0    | 0     | 0 | 0                      | 0    | 1     | 0 | 1                      | 0    | 0     | 0 | 2     | 57            |
| 1:20 PM                         | 1                         | 1    | 6     | 0 | 0                         | 0    | 0     | 0 | 0                      | 0    | 1     | 0 | 2                      | 0    | 0     | 0 | 11    | 66            |
| 1:25 PM                         | 1                         | 1    | 0     | 0 | 0                         | 0    | 0     | 0 | 0                      | 0    | 0     | 0 | 0                      | 0    | 0     | 0 | 2     | 66            |
| 1:30 PM                         | 1                         | 2    | 1     | 0 | 0                         | 0    | 1     | 0 | 0                      | 1    | 1     | 0 | 2                      | 0    | 1     | 0 | 10    | 71            |
| 1:35 PM                         | 0                         | 0    | 1     | 0 | 0                         | 1    | 0     | 0 | 0                      | 1    | 0     | 0 | 0                      | 0    | 1     | 0 | 4     | 63            |
| 1:40 PM                         | 0                         | 0    | 1     | 0 | 0                         | 1    | 1     | 0 | 0                      | 0    | 0     | 0 | 1                      | 0    | 0     | 0 | 4     | 63            |
| 1:45 PM                         | 0                         | 0    | 2     | 0 | 0                         | 1    | 0     | 0 | 0                      | 0    | 1     | 0 | 0                      | 0    | 0     | 0 | 4     | 62            |
| 1:50 PM                         | 1                         | 0    | 1     | 0 | 0                         | 1    | 0     | 0 | 0                      | 0    | 1     | 0 | 1                      | 0    | 0     | 0 | 5     | 65            |
| 1:55 PM                         | 0                         | 0    | 3     | 0 | 0                         | 0    | 0     | 0 | 0                      | 0    | 0     | 0 | 0                      | 0    | 0     | 0 | 3     | 64            |
| 2:00 PM                         | 1                         | 0    | 1     | 0 | 0                         | 0    | 0     | 0 | 0                      | 0    | 0     | 0 | 2                      | 0    | 0     | 0 | 4     | 60            |
| 2:05 PM                         | 0                         | 2    | 0     | 0 | 0                         | 0    | 0     | 0 | 0                      | 0    | 0     | 0 | 2                      | 0    | 1     | 0 | 5     | 60            |
| 2:10 PM                         | 0                         | 0    | 0     | 0 | 0                         | 1    | 0     | 0 | 0                      | 0    | 0     | 0 | 0                      | 0    | 0     | 0 | 1     | 55            |
| 2:15 PM                         | 1                         | 2    | 0     | 0 | 0                         | 1    | 1     | 0 | 0                      | 0    | 0     | 0 | 0                      | 0    | 0     | 0 | 5     | 58            |
| 2:20 PM                         | 0                         | 2    | 1     | 0 | 0                         | 0    | 0     | 0 | 0                      | 0    | 1     | 0 | 2                      | 0    | 0     | 0 | 6     | 53            |
| 2:25 PM                         | 0                         | 1    | 0     | 0 | 0                         | 1    | 0     | 0 | 0                      | 0    | 2     | 0 | 1                      | 0    | 0     | 0 | 5     | 56            |
| 2:30 PM                         | 1                         | 0    | 0     | 0 | 0                         | 1    | 0     | 0 | 0                      | 0    | 0     | 0 | 1                      | 0    | 0     | 0 | 3     | 49            |
| 2:35 PM                         | 0                         | 0    | 1     | 0 | 0                         | 0    | 0     | 0 | 0                      | 0    | 1     | 0 | 2                      | 0    | 0     | 0 | 4     | 49            |
| 2:40 PM                         | 0                         | 0    | 1     | 0 | 0                         | 0    | 0     | 0 | 0                      | 0    | 1     | 0 | 0                      | 0    | 0     | 0 | 2     | 47            |
| 2:45 PM                         | 0                         | 0    | 0     | 0 | 0                         | 0    | 0     | 0 | 0                      | 0    | 1     | 0 | 2                      | 0    | 0     | 0 | 3     | 46            |
| 2:50 PM                         | 2                         | 0    | 4     | 1 | 0                         | 0    | 0     | 0 | 0                      | 0    | 1     | 0 | 1                      | 0    | 0     | 0 | 9     | 50            |
| 2:55 PM                         | 2                         | 1    | 1     | 0 | 0                         | 0    | 0     | 0 | 0                      | 0    | 1     | 0 | 3                      | 0    | 0     | 0 | 8     | 55            |
| 3:00 PM                         | 0                         | 0    | 1     | 0 | 0                         | 1    | 0     | 0 | 0                      | 0    | 0     | 0 | 0                      | 0    | 0     | 0 | 2     | 53            |
| 3:05 PM                         | 2                         | 1    | 2     | 0 | 0                         | 2    | 0     | 0 | 0                      | 0    | 0     | 0 | 2                      | 0    | 0     | 0 | 9     | 57            |
| 3:10 PM                         | 2                         | 3    | 0     | 0 | 0                         | 0    | 0     | 0 | 0                      | 0    | 1     | 0 | 2                      | 0    | 0     | 0 | 8     | 64            |
| 3:15 PM                         | 1                         | 2    | 2     | 0 | 0                         | 1    | 0     | 0 | 0                      | 0    | 0     | 0 | 1                      | 0    | 0     | 0 | 7     | 66            |
| 3:20 PM                         | 0                         | 1    | 2     | 0 | 0                         | 2    | 0     | 0 | 0                      | 0    | 0     | 0 | 0                      | 0    | 0     | 0 | 5     | 65            |
| 3:25 PM                         | 1                         | 1    | 1     | 0 | 0                         | 0    | 0     | 0 | 0                      | 0    | 1     | 0 | 0                      | 0    | 0     | 0 | 4     | 64            |
| 3:30 PM                         | 0                         | 0    | 1     | 0 | 0                         | 1    | 0     | 0 | 0                      | 0    | 2     | 0 | 0                      | 0    | 0     | 0 | 4     | 65            |
| 3:35 PM                         | 0                         | 1    | 0     | 0 | 0                         | 1    | 0     | 0 | 0                      | 0    | 0     | 0 | 2                      | 0    | 0     | 0 | 4     | 65            |
| 3:40 PM                         | 1                         | 1    | 0     | 0 | 0                         | 0    | 0     | 0 | 0                      | 0    | 0     | 0 | 0                      | 0    | 0     | 0 | 2     | 65            |
| 3:45 PM                         | 1                         | 0    | 1     | 0 | 0                         | 1    | 0     | 0 | 0                      | 0    | 0     | 0 | 1                      | 0    | 0     | 0 | 4     | 66            |
| 3:50 PM                         | 1                         | 1    | 3     | 0 | 0                         | 1    | 0     | 0 | 0                      | 0    | 1     | 0 | 1                      | 0    | 1     | 0 | 9     | 66            |
| 3:55 PM                         | 1                         | 0    | 0     | 0 | 0                         | 1    | 1     | 0 | 0                      | 0    | 0     | 0 | 1                      | 0    | 0     | 0 | 4     | 62            |
| 4:00 PM                         | 0                         | 0    | 4     | 0 | 0                         | 1    | 0     | 0 | 0                      | 0    | 1     | 0 | 0                      | 0    | 0     | 0 | 6     | 66            |
| 4:05 PM                         | 1                         | 0    | 4     | 0 | 0                         | 0    | 0     | 0 | 0                      | 0    | 2     | 0 | 0                      | 0    | 0     | 0 | 7     | 64            |
| 4:10 PM                         | 0                         | 2    | 0     | 0 | 0                         | 1    | 0     | 0 | 0                      | 0    | 0     | 0 | 1                      | 0    | 0     | 0 | 4     | 60            |
| 4:15 PM                         | 0                         | 0    | 2     | 0 | 0                         | 2    | 0     | 0 | 0                      | 0    | 1     | 0 | 5                      | 0    | 0     | 0 | 10    | 63            |
| 4:20 PM                         | 0                         | 0    | 1     | 0 | 0                         | 0    | 0     | 0 | 0                      | 0    | 1     | 0 | 0                      | 0    | 0     | 0 | 2     | 60            |
| 4:25 PM                         | 2                         | 2    | 1     | 0 | 0                         | 1    | 0     | 0 | 0                      | 0    | 0     | 0 | 0                      | 1    | 0     | 0 | 7     | 63            |
| 4:30 PM                         | 2                         | 0    | 1     | 0 | 0                         | 0    | 0     | 0 | 0                      | 1    | 2     | 0 | 2                      | 0    | 0     | 0 | 8     | 67            |

**Attachment B**

| 5-Min Count Period Beginning At | Blakemore Dr (Northbound) |      |       |   | Blakemore Dr (Southbound) |      |       |   | Kempton Ln (Eastbound) |      |       |   | Kempton Ln (Westbound) |      |       |   | Total | Hourly Totals |
|---------------------------------|---------------------------|------|-------|---|---------------------------|------|-------|---|------------------------|------|-------|---|------------------------|------|-------|---|-------|---------------|
|                                 | Left                      | Thru | Right | U | Left                      | Thru | Right | U | Left                   | Thru | Right | U | Left                   | Thru | Right | U |       |               |
| 4:35 PM                         | 1                         | 2    | 1     | 0 | 0                         | 1    | 0     | 0 | 0                      | 0    | 1     | 0 | 1                      | 0    | 0     | 0 | 7     | 70            |
| 4:40 PM                         | 1                         | 0    | 3     | 0 | 0                         | 1    | 0     | 0 | 0                      | 0    | 0     | 1 | 0                      | 3    | 0     | 0 | 9     | 77            |
| 4:45 PM                         | 0                         | 1    | 2     | 0 | 0                         | 1    | 0     | 0 | 0                      | 0    | 0     | 0 | 0                      | 1    | 0     | 0 | 5     | 78            |
| 4:50 PM                         | 1                         | 2    | 1     | 0 | 0                         | 0    | 0     | 0 | 0                      | 0    | 0     | 0 | 0                      | 1    | 0     | 0 | 5     | 74            |
| 4:55 PM                         | 1                         | 2    | 1     | 0 | 0                         | 0    | 0     | 0 | 0                      | 0    | 0     | 0 | 0                      | 0    | 0     | 0 | 4     | 74            |
| 5:00 PM                         | 1                         | 0    | 1     | 0 | 0                         | 0    | 0     | 0 | 0                      | 0    | 0     | 1 | 0                      | 0    | 0     | 0 | 3     | 71            |
| 5:05 PM                         | 0                         | 1    | 1     | 0 | 0                         | 1    | 0     | 0 | 0                      | 0    | 0     | 0 | 0                      | 4    | 0     | 0 | 7     | 71            |
| 5:10 PM                         | 0                         | 0    | 3     | 0 | 0                         | 2    | 0     | 0 | 0                      | 0    | 0     | 0 | 0                      | 0    | 0     | 0 | 5     | 72            |
| 5:15 PM                         | 0                         | 3    | 2     | 0 | 0                         | 0    | 0     | 0 | 0                      | 0    | 0     | 0 | 0                      | 3    | 0     | 0 | 8     | 70            |
| 5:20 PM                         | 1                         | 1    | 0     | 0 | 0                         | 0    | 0     | 0 | 0                      | 0    | 0     | 1 | 0                      | 1    | 0     | 0 | 4     | 72            |
| 5:25 PM                         | 2                         | 1    | 2     | 0 | 0                         | 2    | 0     | 0 | 0                      | 0    | 0     | 1 | 0                      | 1    | 0     | 0 | 9     | 74            |
| 5:30 PM                         | 0                         | 3    | 0     | 0 | 0                         | 2    | 0     | 0 | 0                      | 0    | 0     | 1 | 0                      | 0    | 0     | 0 | 6     | 72            |
| 5:35 PM                         | 0                         | 4    | 1     | 0 | 0                         | 0    | 0     | 0 | 0                      | 0    | 0     | 1 | 0                      | 1    | 0     | 0 | 7     | 72            |
| 5:40 PM                         | 1                         | 2    | 2     | 0 | 0                         | 1    | 0     | 0 | 0                      | 0    | 0     | 0 | 0                      | 3    | 0     | 0 | 9     | 72            |
| 5:45 PM                         | 3                         | 1    | 2     | 0 | 0                         | 1    | 0     | 0 | 0                      | 0    | 0     | 1 | 0                      | 1    | 0     | 0 | 9     | 76            |
| 5:50 PM                         | 1                         | 1    | 3     | 0 | 0                         | 1    | 0     | 0 | 0                      | 1    | 0     | 0 | 0                      | 1    | 0     | 0 | 8     | 79            |
| 5:55 PM                         | 0                         | 2    | 3     | 0 | 0                         | 1    | 0     | 0 | 0                      | 0    | 0     | 1 | 0                      | 1    | 0     | 0 | 8     | 83            |
| 6:00 PM                         | 1                         | 1    | 0     | 0 | 0                         | 1    | 0     | 0 | 0                      | 0    | 0     | 1 | 0                      | 1    | 0     | 0 | 5     | 85            |
| 6:05 PM                         | 0                         | 0    | 1     | 0 | 0                         | 2    | 0     | 0 | 0                      | 0    | 0     | 0 | 0                      | 1    | 0     | 0 | 4     | 82            |
| 6:10 PM                         | 0                         | 0    | 6     | 0 | 0                         | 0    | 0     | 0 | 0                      | 0    | 0     | 0 | 0                      | 2    | 0     | 0 | 8     | 85            |
| 6:15 PM                         | 0                         | 1    | 0     | 0 | 0                         | 1    | 0     | 0 | 0                      | 0    | 0     | 0 | 0                      | 0    | 0     | 0 | 2     | 79            |
| 6:20 PM                         | 1                         | 0    | 4     | 0 | 0                         | 0    | 0     | 0 | 0                      | 0    | 0     | 0 | 0                      | 1    | 0     | 0 | 6     | 81            |
| 6:25 PM                         | 1                         | 1    | 0     | 0 | 0                         | 1    | 0     | 0 | 0                      | 0    | 0     | 0 | 0                      | 1    | 0     | 0 | 4     | 76            |
| 6:30 PM                         | 0                         | 0    | 0     | 0 | 0                         | 0    | 0     | 0 | 0                      | 0    | 0     | 0 | 0                      | 0    | 0     | 0 | 0     | 70            |
| 6:35 PM                         | 1                         | 1    | 1     | 0 | 0                         | 1    | 0     | 0 | 0                      | 0    | 0     | 0 | 0                      | 1    | 0     | 0 | 5     | 68            |
| 6:40 PM                         | 3                         | 0    | 1     | 0 | 0                         | 2    | 0     | 0 | 0                      | 0    | 0     | 0 | 0                      | 2    | 0     | 0 | 8     | 67            |
| 6:45 PM                         | 0                         | 0    | 0     | 0 | 0                         | 0    | 0     | 0 | 0                      | 0    | 1     | 0 | 0                      | 1    | 0     | 0 | 2     | 60            |
| 6:50 PM                         | 0                         | 2    | 0     | 0 | 0                         | 1    | 0     | 0 | 0                      | 0    | 0     | 1 | 0                      | 0    | 0     | 0 | 4     | 56            |
| 6:55 PM                         | 0                         | 1    | 0     | 0 | 0                         | 1    | 0     | 0 | 0                      | 0    | 0     | 0 | 0                      | 1    | 0     | 0 | 3     | 51            |
| 7:00 PM                         | 2                         | 3    | 1     | 0 | 0                         | 0    | 0     | 0 | 0                      | 0    | 0     | 0 | 0                      | 1    | 0     | 0 | 7     | 53            |
| 7:05 PM                         | 0                         | 1    | 0     | 0 | 0                         | 0    | 0     | 0 | 0                      | 0    | 0     | 0 | 0                      | 2    | 0     | 0 | 3     | 52            |
| 7:10 PM                         | 0                         | 3    | 2     | 0 | 0                         | 0    | 0     | 0 | 0                      | 0    | 0     | 0 | 0                      | 1    | 0     | 0 | 6     | 50            |
| 7:15 PM                         | 1                         | 2    | 3     | 0 | 0                         | 1    | 0     | 0 | 0                      | 0    | 0     | 0 | 0                      | 1    | 0     | 0 | 8     | 56            |
| 7:20 PM                         | 3                         | 2    | 1     | 0 | 0                         | 1    | 0     | 0 | 0                      | 0    | 0     | 0 | 0                      | 0    | 0     | 0 | 7     | 57            |
| 7:25 PM                         | 0                         | 1    | 2     | 0 | 0                         | 0    | 0     | 0 | 0                      | 0    | 0     | 0 | 0                      | 1    | 0     | 0 | 4     | 57            |
| 7:30 PM                         | 0                         | 0    | 2     | 0 | 0                         | 0    | 0     | 0 | 0                      | 0    | 0     | 0 | 0                      | 0    | 0     | 0 | 2     | 59            |
| 7:35 PM                         | 0                         | 1    | 0     | 0 | 0                         | 0    | 0     | 0 | 0                      | 0    | 0     | 0 | 0                      | 0    | 0     | 0 | 1     | 55            |
| 7:40 PM                         | 0                         | 0    | 2     | 0 | 0                         | 0    | 0     | 0 | 0                      | 0    | 0     | 1 | 0                      | 1    | 0     | 0 | 4     | 51            |
| 7:45 PM                         | 0                         | 1    | 1     | 0 | 0                         | 1    | 0     | 0 | 0                      | 0    | 0     | 0 | 0                      | 0    | 0     | 0 | 3     | 52            |
| 7:50 PM                         | 0                         | 1    | 0     | 0 | 0                         | 0    | 0     | 0 | 0                      | 0    | 0     | 0 | 0                      | 0    | 0     | 0 | 1     | 49            |
| 7:55 PM                         | 0                         | 1    | 0     | 0 | 0                         | 1    | 0     | 0 | 0                      | 0    | 0     | 0 | 0                      | 0    | 0     | 0 | 2     | 48            |
| 8:00 PM                         | 0                         | 0    | 0     | 0 | 0                         | 1    | 0     | 0 | 0                      | 0    | 0     | 0 | 0                      | 1    | 0     | 0 | 2     | 43            |
| 8:05 PM                         | 0                         | 1    | 0     | 0 | 0                         | 0    | 0     | 0 | 0                      | 0    | 0     | 0 | 0                      | 1    | 0     | 0 | 2     | 42            |
| 8:10 PM                         | 0                         | 2    | 1     | 0 | 0                         | 0    | 0     | 0 | 0                      | 0    | 0     | 0 | 0                      | 0    | 0     | 0 | 3     | 39            |
| 8:15 PM                         | 0                         | 0    | 0     | 0 | 0                         | 0    | 0     | 0 | 0                      | 0    | 0     | 0 | 0                      | 1    | 0     | 0 | 1     | 32            |
| 8:20 PM                         | 0                         | 1    | 0     | 0 | 0                         | 1    | 0     | 0 | 0                      | 0    | 0     | 0 | 0                      | 0    | 0     | 0 | 2     | 27            |
| 8:25 PM                         | 0                         | 0    | 0     | 0 | 0                         | 1    | 0     | 0 | 0                      | 0    | 0     | 0 | 0                      | 1    | 0     | 0 | 2     | 25            |
| 8:30 PM                         | 0                         | 0    | 0     | 0 | 0                         | 1    | 0     | 0 | 0                      | 0    | 0     | 0 | 0                      | 0    | 0     | 0 | 1     | 24            |
| 8:35 PM                         | 0                         | 0    | 2     | 0 | 0                         | 0    | 0     | 0 | 0                      | 0    | 0     | 0 | 0                      | 0    | 0     | 0 | 2     | 25            |
| 8:40 PM                         | 0                         | 0    | 1     | 0 | 0                         | 0    | 0     | 0 | 0                      | 0    | 0     | 0 | 0                      | 0    | 0     | 0 | 1     | 22            |
| 8:45 PM                         | 0                         | 2    | 0     | 0 | 0                         | 0    | 0     | 0 | 0                      | 0    | 0     | 0 | 0                      | 0    | 0     | 0 | 2     | 21            |
| 8:50 PM                         | 0                         | 1    | 1     | 0 | 0                         | 1    | 0     | 0 | 0                      | 0    | 0     | 0 | 0                      | 0    | 0     | 0 | 3     | 23            |
| 8:55 PM                         | 2                         | 0    | 0     | 0 | 0                         | 0    | 0     | 0 | 0                      | 0    | 0     | 1 | 0                      | 0    | 0     | 0 | 3     | 24            |
| 9:00 PM                         | 0                         | 0    | 0     | 0 | 0                         | 0    | 0     | 0 | 0                      | 0    | 0     | 0 | 0                      | 0    | 0     | 0 | 0     | 22            |
| 9:05 PM                         | 0                         | 0    | 0     | 0 | 0                         | 0    | 0     | 0 | 0                      | 0    | 0     | 0 | 0                      | 0    | 0     | 0 | 0     | 20            |
| 9:10 PM                         | 0                         | 0    | 0     | 0 | 0                         | 0    | 0     | 0 | 0                      | 0    | 0     | 0 | 0                      | 0    | 0     | 0 | 0     | 17            |
| 9:15 PM                         | 0                         | 0    | 2     | 0 | 0                         | 0    | 0     | 0 | 0                      | 0    | 0     | 0 | 0                      | 1    | 0     | 0 | 3     | 19            |
| 9:20 PM                         | 0                         | 1    | 2     | 0 | 0                         | 0    | 0     | 0 | 0                      | 0    | 0     | 0 | 0                      | 0    | 0     | 0 | 3     | 20            |
| 9:25 PM                         | 0                         | 0    | 0     | 0 | 0                         | 1    | 0     | 0 | 0                      | 0    | 0     | 0 | 0                      | 0    | 0     | 0 | 1     | 19            |
| 9:30 PM                         | 2                         | 0    | 0     | 0 | 0                         | 0    | 0     | 0 | 0                      | 0    | 0     | 0 | 0                      | 0    | 0     | 0 | 2     | 20            |
| 9:35 PM                         | 0                         | 1    | 0     | 0 | 0                         | 0    | 0     | 0 | 0                      | 0    | 0     | 0 | 0                      | 0    | 0     | 0 | 1     | 19            |
| 9:40 PM                         | 0                         | 1    | 1     | 0 | 0                         | 0    | 0     | 0 | 0                      | 0    | 0     | 0 | 0                      | 1    | 0     | 0 | 3     | 21            |
| 9:45 PM                         | 0                         | 1    | 2     | 0 | 0                         | 0    | 0     | 0 | 0                      | 0    | 0     | 0 | 0                      | 0    | 0     | 0 | 3     | 22            |
| 9:50 PM                         | 0                         | 0    | 2     | 0 | 0                         | 0    | 0     | 0 | 0                      | 0    | 0     | 0 | 0                      | 0    | 0     | 0 | 2     | 21            |
| 9:55 PM                         | 0                         | 0    | 0     | 0 | 0                         | 1    | 0     | 0 | 0                      | 0    | 0     | 0 | 0                      | 0    | 0     | 0 | 1     | 19            |
| Peak 15-Min Flowrates           | Northbound                |      |       |   | Southbound                |      |       |   | Eastbound              |      |       |   | Westbound              |      |       |   | Total |               |
|                                 | Left                      | Thru | Right | U | Left                      | Thru | Right | U | Left                   | Thru | Right | U | Left                   | Thru | Right | U |       |               |
| All Vehicles                    | 20                        | 16   | 28    | 0 | 0                         | 12   | 0     | 0 | 4                      | 0    | 4     | 0 | 20                     | 0    | 0     | 0 | 104   |               |
| Heavy Trucks                    | 0                         | 0    | 0     | 0 | 0                         | 0    | 0     | 0 | 0                      | 0    | 0     | 0 | 0                      | 0    | 0     | 0 | 0     |               |
| Buses                           |                           |      |       |   |                           |      |       |   |                        |      |       |   |                        |      |       |   |       |               |
| Pedestrians                     |                           | 0    |       |   |                           | 0    |       |   |                        | 0    |       |   |                        | 0    |       |   | 0     |               |
| Bicycles                        | 0                         | 0    | 0     |   | 0                         | 0    | 4     |   | 4                      | 0    | 0     |   | 0                      | 0    | 0     |   | 8     |               |
| Scoters                         |                           |      |       |   |                           |      |       |   |                        |      |       |   |                        |      |       |   |       |               |

Comments:

LOCATION: Reston Way -- Main St  
 CITY/STATE: Ladera Ranch, CA

QC JOB #: 16966458  
 DATE: Wed, Apr 16 2025

Peak-Hour: 5:30 PM -- 6:30 PM  
 Peak 15-Min: 5:30 PM -- 5:45 PM

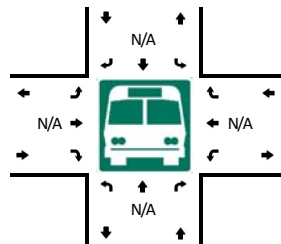
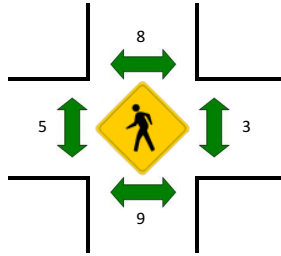
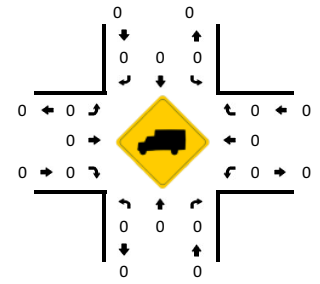
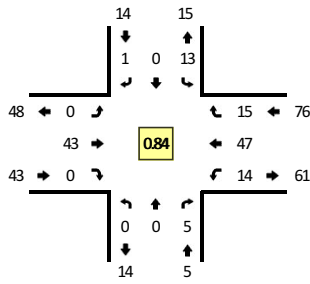

| 5-Min Count Period Beginning At | Reston Way (Northbound) |      |       |   | Reston Way (Southbound) |      |       |   | Main St (Eastbound) |      |       |   | Main St (Westbound) |      |       |   | Total | Hourly Totals |    |     |
|---------------------------------|-------------------------|------|-------|---|-------------------------|------|-------|---|---------------------|------|-------|---|---------------------|------|-------|---|-------|---------------|----|-----|
|                                 | Left                    | Thru | Right | U | Left                    | Thru | Right | U | Left                | Thru | Right | U | Left                | Thru | Right | U |       |               |    |     |
| 6:00 AM                         | 0                       | 0    | 1     | 0 | 0                       | 0    | 0     | 0 | 0                   | 0    | 0     | 0 | 0                   | 1    | 0     | 0 | 0     | 2             |    |     |
| 6:05 AM                         | 0                       | 0    | 0     | 0 | 0                       | 0    | 0     | 0 | 0                   | 0    | 1     | 0 | 0                   | 0    | 1     | 0 | 0     | 0             | 2  |     |
| 6:10 AM                         | 0                       | 0    | 0     | 0 | 0                       | 0    | 0     | 0 | 0                   | 0    | 0     | 0 | 0                   | 0    | 0     | 0 | 0     | 0             | 0  |     |
| 6:15 AM                         | 0                       | 0    | 0     | 0 | 1                       | 0    | 0     | 0 | 0                   | 0    | 0     | 0 | 0                   | 0    | 0     | 0 | 0     | 0             | 1  |     |
| 6:20 AM                         | 0                       | 0    | 0     | 0 | 2                       | 0    | 0     | 0 | 0                   | 0    | 0     | 0 | 0                   | 0    | 0     | 0 | 0     | 0             | 2  |     |
| 6:25 AM                         | 0                       | 0    | 0     | 0 | 0                       | 0    | 0     | 0 | 0                   | 0    | 1     | 0 | 0                   | 0    | 0     | 0 | 0     | 0             | 1  |     |
| 6:30 AM                         | 0                       | 0    | 0     | 0 | 2                       | 0    | 0     | 0 | 0                   | 0    | 2     | 0 | 0                   | 0    | 0     | 1 | 0     | 0             | 5  |     |
| 6:35 AM                         | 0                       | 0    | 2     | 0 | 1                       | 0    | 0     | 0 | 0                   | 0    | 0     | 0 | 0                   | 0    | 0     | 1 | 0     | 0             | 4  |     |
| 6:40 AM                         | 0                       | 0    | 1     | 0 | 0                       | 0    | 0     | 0 | 0                   | 0    | 2     | 0 | 0                   | 0    | 0     | 0 | 0     | 0             | 3  |     |
| 6:45 AM                         | 0                       | 0    | 0     | 0 | 0                       | 0    | 0     | 0 | 0                   | 0    | 2     | 0 | 0                   | 0    | 0     | 0 | 0     | 0             | 2  |     |
| 6:50 AM                         | 0                       | 0    | 0     | 0 | 2                       | 0    | 0     | 0 | 0                   | 0    | 3     | 0 | 0                   | 0    | 0     | 0 | 0     | 0             | 5  |     |
| 6:55 AM                         | 0                       | 0    | 1     | 0 | 1                       | 0    | 0     | 0 | 0                   | 0    | 2     | 0 | 0                   | 0    | 0     | 0 | 0     | 0             | 4  | 31  |
| 7:00 AM                         | 0                       | 0    | 1     | 0 | 0                       | 0    | 0     | 0 | 0                   | 0    | 4     | 0 | 0                   | 0    | 2     | 0 | 0     | 0             | 7  | 36  |
| 7:05 AM                         | 0                       | 0    | 1     | 0 | 0                       | 0    | 0     | 0 | 0                   | 0    | 2     | 0 | 0                   | 0    | 1     | 0 | 0     | 0             | 4  | 38  |
| 7:10 AM                         | 0                       | 0    | 2     | 0 | 0                       | 0    | 0     | 0 | 0                   | 0    | 0     | 0 | 0                   | 0    | 0     | 1 | 0     | 0             | 3  | 41  |
| 7:15 AM                         | 0                       | 0    | 1     | 0 | 1                       | 0    | 0     | 0 | 0                   | 0    | 3     | 0 | 0                   | 0    | 3     | 0 | 0     | 0             | 8  | 48  |
| 7:20 AM                         | 0                       | 0    | 1     | 0 | 0                       | 0    | 0     | 0 | 0                   | 0    | 5     | 0 | 0                   | 0    | 2     | 2 | 0     | 0             | 10 | 56  |
| 7:25 AM                         | 0                       | 0    | 3     | 0 | 0                       | 0    | 1     | 0 | 0                   | 0    | 3     | 0 | 0                   | 0    | 1     | 2 | 0     | 0             | 10 | 65  |
| 7:30 AM                         | 0                       | 0    | 0     | 0 | 1                       | 0    | 0     | 0 | 0                   | 0    | 4     | 0 | 0                   | 0    | 0     | 0 | 0     | 0             | 5  | 65  |
| 7:35 AM                         | 0                       | 0    | 0     | 0 | 0                       | 1    | 0     | 0 | 0                   | 0    | 2     | 0 | 0                   | 0    | 3     | 0 | 0     | 0             | 6  | 67  |
| 7:40 AM                         | 0                       | 0    | 0     | 0 | 2                       | 0    | 0     | 0 | 0                   | 0    | 3     | 0 | 0                   | 0    | 0     | 0 | 0     | 0             | 5  | 69  |
| 7:45 AM                         | 1                       | 0    | 1     | 0 | 5                       | 0    | 0     | 0 | 0                   | 0    | 7     | 0 | 0                   | 0    | 3     | 1 | 0     | 0             | 18 | 85  |
| 7:50 AM                         | 0                       | 0    | 0     | 0 | 3                       | 0    | 0     | 0 | 0                   | 0    | 6     | 0 | 0                   | 0    | 1     | 3 | 0     | 0             | 13 | 93  |
| 7:55 AM                         | 0                       | 0    | 0     | 0 | 2                       | 0    | 0     | 0 | 0                   | 0    | 6     | 0 | 0                   | 1    | 1     | 2 | 0     | 0             | 12 | 101 |
| 8:00 AM                         | 0                       | 0    | 0     | 0 | 2                       | 0    | 0     | 0 | 0                   | 0    | 3     | 0 | 0                   | 1    | 5     | 2 | 0     | 0             | 13 | 107 |
| 8:05 AM                         | 0                       | 0    | 2     | 0 | 1                       | 0    | 0     | 0 | 0                   | 0    | 0     | 0 | 0                   | 1    | 3     | 2 | 0     | 0             | 9  | 112 |
| 8:10 AM                         | 0                       | 0    | 0     | 0 | 3                       | 0    | 0     | 0 | 0                   | 0    | 5     | 0 | 0                   | 0    | 2     | 2 | 0     | 0             | 12 | 121 |
| 8:15 AM                         | 0                       | 0    | 1     | 0 | 1                       | 0    | 0     | 0 | 0                   | 0    | 2     | 0 | 0                   | 1    | 3     | 0 | 0     | 0             | 8  | 121 |
| 8:20 AM                         | 0                       | 0    | 2     | 0 | 2                       | 0    | 0     | 0 | 0                   | 0    | 0     | 0 | 0                   | 0    | 1     | 0 | 0     | 0             | 5  | 116 |
| 8:25 AM                         | 0                       | 0    | 0     | 0 | 1                       | 0    | 0     | 0 | 0                   | 0    | 3     | 0 | 0                   | 1    | 1     | 0 | 0     | 0             | 6  | 112 |
| 8:30 AM                         | 0                       | 0    | 1     | 0 | 3                       | 0    | 0     | 0 | 0                   | 0    | 1     | 0 | 0                   | 1    | 2     | 0 | 0     | 0             | 8  | 115 |
| 8:35 AM                         | 0                       | 0    | 0     | 0 | 5                       | 0    | 0     | 0 | 0                   | 0    | 3     | 0 | 0                   | 1    | 1     | 1 | 0     | 0             | 11 | 120 |
| 8:40 AM                         | 0                       | 0    | 0     | 0 | 1                       | 0    | 0     | 0 | 0                   | 0    | 1     | 0 | 0                   | 0    | 0     | 1 | 0     | 0             | 3  | 118 |
| 8:45 AM                         | 0                       | 0    | 0     | 0 | 0                       | 0    | 0     | 0 | 0                   | 0    | 1     | 0 | 0                   | 1    | 1     | 1 | 0     | 0             | 4  | 104 |
| 8:50 AM                         | 0                       | 0    | 0     | 0 | 1                       | 0    | 0     | 0 | 0                   | 0    | 3     | 0 | 0                   | 0    | 3     | 1 | 0     | 0             | 8  | 99  |
| 8:55 AM                         | 0                       | 0    | 0     | 0 | 1                       | 0    | 0     | 0 | 0                   | 0    | 3     | 0 | 0                   | 2    | 1     | 0 | 0     | 0             | 7  | 94  |
| 9:00 AM                         | 0                       | 0    | 2     | 0 | 0                       | 0    | 0     | 0 | 0                   | 0    | 1     | 0 | 0                   | 0    | 1     | 1 | 0     | 0             | 5  | 86  |
| 9:05 AM                         | 0                       | 0    | 0     | 0 | 1                       | 0    | 0     | 0 | 0                   | 0    | 1     | 0 | 0                   | 0    | 1     | 0 | 0     | 0             | 3  | 80  |

**Attachment B**

| 5-Min Count Period Beginning At | Reston Way (Northbound) |      |       |   | Reston Way (Southbound) |      |       |   | Main St (Eastbound) |      |       |   | Main St (Westbound) |      |       |   | Total | Hourly Totals |     |
|---------------------------------|-------------------------|------|-------|---|-------------------------|------|-------|---|---------------------|------|-------|---|---------------------|------|-------|---|-------|---------------|-----|
|                                 | Left                    | Thru | Right | U | Left                    | Thru | Right | U | Left                | Thru | Right | U | Left                | Thru | Right | U |       |               |     |
| 9:10 AM                         | 0                       | 0    | 1     | 0 | 2                       | 0    | 0     | 0 | 0                   | 1    | 0     | 0 | 0                   | 1    | 0     | 0 | 0     | 5             | 73  |
| 9:15 AM                         | 0                       | 0    | 1     | 0 | 0                       | 0    | 0     | 0 | 0                   | 0    | 4     | 0 | 0                   | 1    | 2     | 2 | 0     | 10            | 75  |
| 9:20 AM                         | 0                       | 0    | 1     | 0 | 2                       | 0    | 0     | 0 | 0                   | 0    | 2     | 0 | 0                   | 0    | 0     | 1 | 0     | 6             | 76  |
| 9:25 AM                         | 0                       | 0    | 0     | 0 | 0                       | 0    | 0     | 0 | 0                   | 0    | 2     | 0 | 0                   | 0    | 3     | 0 | 0     | 5             | 75  |
| 9:30 AM                         | 0                       | 0    | 1     | 0 | 0                       | 0    | 0     | 0 | 0                   | 0    | 0     | 0 | 0                   | 0    | 1     | 2 | 0     | 4             | 71  |
| 9:35 AM                         | 0                       | 0    | 1     | 0 | 1                       | 0    | 0     | 0 | 0                   | 0    | 1     | 0 | 0                   | 0    | 1     | 1 | 0     | 5             | 65  |
| 9:40 AM                         | 1                       | 0    | 0     | 0 | 1                       | 0    | 0     | 0 | 0                   | 0    | 4     | 0 | 0                   | 0    | 1     | 2 | 0     | 9             | 71  |
| 9:45 AM                         | 0                       | 0    | 0     | 0 | 1                       | 0    | 0     | 0 | 0                   | 0    | 2     | 0 | 0                   | 0    | 3     | 0 | 0     | 6             | 73  |
| 9:50 AM                         | 0                       | 0    | 0     | 0 | 0                       | 0    | 1     | 0 | 0                   | 0    | 3     | 0 | 0                   | 0    | 1     | 2 | 0     | 7             | 72  |
| 9:55 AM                         | 0                       | 0    | 1     | 0 | 0                       | 0    | 0     | 0 | 0                   | 0    | 1     | 0 | 0                   | 0    | 0     | 0 | 0     | 2             | 67  |
| 10:00 AM                        | 0                       | 0    | 0     | 0 | 0                       | 0    | 0     | 0 | 0                   | 0    | 1     | 0 | 0                   | 0    | 2     | 0 | 0     | 3             | 65  |
| 10:05 AM                        | 0                       | 0    | 0     | 0 | 2                       | 0    | 0     | 0 | 0                   | 1    | 0     | 0 | 0                   | 0    | 6     | 2 | 0     | 11            | 73  |
| 10:10 AM                        | 0                       | 0    | 0     | 0 | 3                       | 0    | 0     | 0 | 0                   | 0    | 1     | 1 | 0                   | 1    | 1     | 1 | 0     | 8             | 76  |
| 10:15 AM                        | 0                       | 0    | 1     | 0 | 1                       | 0    | 0     | 0 | 0                   | 0    | 0     | 0 | 0                   | 1    | 0     | 0 | 0     | 3             | 69  |
| 10:20 AM                        | 0                       | 0    | 1     | 0 | 0                       | 0    | 0     | 0 | 0                   | 0    | 2     | 1 | 0                   | 0    | 1     | 0 | 0     | 5             | 68  |
| 10:25 AM                        | 0                       | 0    | 0     | 0 | 0                       | 0    | 0     | 0 | 0                   | 0    | 3     | 0 | 0                   | 0    | 1     | 0 | 0     | 4             | 67  |
| 10:30 AM                        | 0                       | 0    | 0     | 0 | 1                       | 0    | 0     | 0 | 0                   | 0    | 2     | 0 | 0                   | 1    | 2     | 1 | 0     | 7             | 70  |
| 10:35 AM                        | 0                       | 0    | 2     | 0 | 4                       | 0    | 0     | 0 | 0                   | 0    | 4     | 1 | 0                   | 0    | 2     | 0 | 0     | 13            | 78  |
| 10:40 AM                        | 0                       | 0    | 2     | 0 | 1                       | 0    | 0     | 0 | 0                   | 0    | 1     | 0 | 0                   | 1    | 0     | 1 | 0     | 6             | 75  |
| 10:45 AM                        | 0                       | 0    | 1     | 0 | 1                       | 0    | 0     | 0 | 0                   | 0    | 1     | 0 | 0                   | 0    | 1     | 1 | 0     | 5             | 74  |
| 10:50 AM                        | 0                       | 0    | 0     | 0 | 1                       | 0    | 1     | 0 | 0                   | 0    | 2     | 0 | 0                   | 0    | 4     | 1 | 0     | 9             | 76  |
| 10:55 AM                        | 0                       | 0    | 0     | 0 | 0                       | 0    | 0     | 0 | 0                   | 0    | 7     | 0 | 0                   | 0    | 2     | 0 | 0     | 9             | 83  |
| 11:00 AM                        | 0                       | 0    | 0     | 0 | 1                       | 0    | 0     | 0 | 0                   | 0    | 0     | 0 | 0                   | 1    | 0     | 0 | 0     | 2             | 82  |
| 11:05 AM                        | 1                       | 0    | 0     | 0 | 0                       | 0    | 0     | 0 | 0                   | 0    | 3     | 0 | 0                   | 2    | 1     | 1 | 0     | 8             | 79  |
| 11:10 AM                        | 0                       | 0    | 1     | 0 | 4                       | 0    | 0     | 0 | 0                   | 0    | 3     | 0 | 0                   | 0    | 0     | 3 | 0     | 11            | 82  |
| 11:15 AM                        | 0                       | 0    | 0     | 0 | 1                       | 0    | 0     | 0 | 0                   | 0    | 2     | 0 | 0                   | 0    | 2     | 0 | 0     | 5             | 84  |
| 11:20 AM                        | 0                       | 0    | 1     | 0 | 0                       | 1    | 0     | 0 | 0                   | 0    | 1     | 0 | 0                   | 0    | 0     | 1 | 0     | 4             | 83  |
| 11:25 AM                        | 0                       | 0    | 0     | 0 | 1                       | 0    | 0     | 0 | 0                   | 0    | 0     | 0 | 0                   | 0    | 1     | 1 | 0     | 3             | 82  |
| 11:30 AM                        | 1                       | 0    | 0     | 0 | 2                       | 0    | 0     | 0 | 0                   | 0    | 2     | 0 | 0                   | 0    | 2     | 2 | 0     | 9             | 84  |
| 11:35 AM                        | 0                       | 0    | 2     | 0 | 0                       | 0    | 1     | 0 | 0                   | 0    | 1     | 0 | 0                   | 1    | 1     | 0 | 0     | 6             | 77  |
| 11:40 AM                        | 0                       | 0    | 1     | 0 | 0                       | 0    | 0     | 0 | 0                   | 0    | 2     | 1 | 0                   | 0    | 3     | 0 | 0     | 7             | 78  |
| 11:45 AM                        | 0                       | 0    | 1     | 0 | 2                       | 0    | 0     | 0 | 0                   | 0    | 0     | 0 | 0                   | 0    | 1     | 0 | 0     | 4             | 77  |
| 11:50 AM                        | 0                       | 0    | 1     | 0 | 2                       | 0    | 0     | 0 | 0                   | 0    | 4     | 0 | 0                   | 1    | 3     | 2 | 0     | 13            | 81  |
| 11:55 AM                        | 0                       | 0    | 0     | 0 | 0                       | 0    | 0     | 0 | 0                   | 0    | 1     | 0 | 0                   | 2    | 4     | 0 | 0     | 7             | 79  |
| 12:00 PM                        | 0                       | 0    | 0     | 0 | 1                       | 0    | 1     | 0 | 0                   | 0    | 3     | 0 | 0                   | 0    | 3     | 2 | 0     | 10            | 87  |
| 12:05 PM                        | 1                       | 0    | 0     | 0 | 0                       | 0    | 0     | 0 | 0                   | 0    | 3     | 0 | 0                   | 0    | 2     | 2 | 0     | 8             | 87  |
| 12:10 PM                        | 0                       | 0    | 2     | 0 | 1                       | 1    | 0     | 0 | 0                   | 0    | 1     | 1 | 0                   | 0    | 2     | 1 | 0     | 9             | 85  |
| 12:15 PM                        | 0                       | 0    | 0     | 0 | 2                       | 0    | 0     | 0 | 0                   | 0    | 3     | 0 | 0                   | 0    | 3     | 2 | 0     | 10            | 90  |
| 12:20 PM                        | 1                       | 0    | 0     | 0 | 0                       | 0    | 0     | 0 | 0                   | 0    | 2     | 0 | 0                   | 0    | 0     | 1 | 0     | 4             | 90  |
| 12:25 PM                        | 0                       | 0    | 1     | 0 | 1                       | 0    | 0     | 0 | 0                   | 0    | 1     | 0 | 0                   | 1    | 0     | 0 | 0     | 4             | 91  |
| 12:30 PM                        | 0                       | 0    | 1     | 0 | 1                       | 0    | 0     | 0 | 0                   | 0    | 1     | 0 | 0                   | 1    | 1     | 0 | 0     | 5             | 87  |
| 12:35 PM                        | 0                       | 0    | 1     | 0 | 0                       | 0    | 0     | 0 | 0                   | 0    | 3     | 0 | 0                   | 0    | 1     | 1 | 0     | 6             | 87  |
| 12:40 PM                        | 0                       | 0    | 0     | 0 | 1                       | 0    | 0     | 0 | 0                   | 0    | 1     | 0 | 0                   | 1    | 1     | 2 | 0     | 6             | 86  |
| 12:45 PM                        | 0                       | 1    | 0     | 0 | 0                       | 0    | 0     | 0 | 0                   | 0    | 3     | 0 | 0                   | 0    | 1     | 1 | 0     | 6             | 88  |
| 12:50 PM                        | 0                       | 0    | 1     | 0 | 0                       | 0    | 1     | 0 | 0                   | 0    | 2     | 0 | 0                   | 0    | 2     | 1 | 0     | 7             | 82  |
| 12:55 PM                        | 0                       | 0    | 1     | 0 | 0                       | 0    | 0     | 0 | 0                   | 0    | 2     | 0 | 0                   | 0    | 1     | 1 | 0     | 5             | 80  |
| 1:00 PM                         | 1                       | 0    | 1     | 0 | 1                       | 1    | 0     | 0 | 0                   | 0    | 2     | 0 | 0                   | 2    | 2     | 1 | 0     | 11            | 81  |
| 1:05 PM                         | 0                       | 0    | 0     | 0 | 2                       | 0    | 0     | 0 | 0                   | 0    | 2     | 0 | 0                   | 1    | 2     | 1 | 0     | 8             | 81  |
| 1:10 PM                         | 0                       | 0    | 1     | 0 | 1                       | 0    | 0     | 0 | 0                   | 0    | 2     | 0 | 1                   | 1    | 10    | 1 | 0     | 17            | 89  |
| 1:15 PM                         | 0                       | 0    | 2     | 0 | 2                       | 0    | 0     | 0 | 0                   | 0    | 3     | 0 | 0                   | 1    | 0     | 6 | 0     | 14            | 93  |
| 1:20 PM                         | 0                       | 0    | 0     | 0 | 0                       | 0    | 0     | 0 | 0                   | 0    | 2     | 0 | 0                   | 0    | 3     | 2 | 0     | 7             | 96  |
| 1:25 PM                         | 0                       | 0    | 0     | 0 | 2                       | 0    | 0     | 0 | 0                   | 0    | 1     | 0 | 0                   | 1    | 1     | 0 | 0     | 5             | 97  |
| 1:30 PM                         | 0                       | 0    | 0     | 0 | 1                       | 0    | 0     | 0 | 0                   | 0    | 0     | 0 | 0                   | 1    | 2     | 0 | 0     | 4             | 96  |
| 1:35 PM                         | 0                       | 0    | 0     | 0 | 1                       | 0    | 0     | 0 | 0                   | 0    | 2     | 0 | 0                   | 0    | 4     | 2 | 0     | 9             | 99  |
| 1:40 PM                         | 0                       | 0    | 0     | 0 | 0                       | 0    | 0     | 0 | 0                   | 0    | 0     | 0 | 0                   | 1    | 0     | 1 | 0     | 2             | 95  |
| 1:45 PM                         | 0                       | 0    | 0     | 0 | 0                       | 0    | 0     | 0 | 0                   | 0    | 2     | 0 | 0                   | 1    | 2     | 1 | 0     | 6             | 95  |
| 1:50 PM                         | 0                       | 0    | 1     | 0 | 1                       | 0    | 0     | 0 | 0                   | 0    | 2     | 0 | 0                   | 1    | 1     | 0 | 0     | 6             | 94  |
| 1:55 PM                         | 0                       | 0    | 1     | 0 | 2                       | 0    | 0     | 0 | 0                   | 0    | 4     | 0 | 0                   | 0    | 3     | 0 | 0     | 10            | 99  |
| 2:00 PM                         | 0                       | 0    | 1     | 0 | 0                       | 0    | 0     | 0 | 0                   | 0    | 2     | 0 | 0                   | 0    | 3     | 1 | 0     | 7             | 95  |
| 2:05 PM                         | 0                       | 0    | 1     | 0 | 0                       | 0    | 0     | 0 | 0                   | 0    | 1     | 0 | 0                   | 0    | 2     | 1 | 0     | 5             | 92  |
| 2:10 PM                         | 0                       | 0    | 3     | 0 | 2                       | 0    | 0     | 0 | 0                   | 0    | 0     | 0 | 0                   | 0    | 3     | 3 | 0     | 11            | 86  |
| 2:15 PM                         | 1                       | 0    | 1     | 0 | 2                       | 0    | 0     | 0 | 0                   | 0    | 4     | 0 | 0                   | 1    | 2     | 0 | 0     | 11            | 83  |
| 2:20 PM                         | 0                       | 0    | 2     | 0 | 2                       | 0    | 0     | 0 | 0                   | 0    | 3     | 0 | 0                   | 1    | 2     | 2 | 0     | 12            | 88  |
| 2:25 PM                         | 0                       | 0    | 0     | 0 | 2                       | 0    | 0     | 0 | 0                   | 0    | 4     | 0 | 0                   | 1    | 2     | 2 | 0     | 11            | 94  |
| 2:30 PM                         | 0                       | 0    | 1     | 0 | 1                       | 0    | 0     | 0 | 0                   | 1    | 0     | 0 | 0                   | 0    | 1     | 2 | 0     | 6             | 96  |
| 2:35 PM                         | 0                       | 0    | 1     | 0 | 2                       | 0    | 1     | 0 | 0                   | 0    | 3     | 0 | 0                   | 1    | 5     | 5 | 0     | 18            | 105 |
| 2:40 PM                         | 0                       | 0    | 1     | 0 | 2                       | 0    | 0     | 0 | 0                   | 0    | 4     | 0 | 0                   | 1    | 0     | 0 | 0     | 8             | 111 |
| 2:45 PM                         | 0                       | 0    | 2     | 0 | 2                       | 0    | 0     | 0 | 0                   | 1    | 4     | 0 | 0                   | 1    | 0     | 1 | 0     | 11            | 116 |
| 2:50 PM                         | 0                       | 0    | 0     | 0 | 1                       | 0    | 0     | 0 | 0                   | 0    | 3     | 0 | 0                   | 0    | 2     | 1 | 0     | 7             | 117 |
| 2:55 PM                         | 0                       | 0    | 1     | 0 | 1                       | 0    | 0     | 0 | 0                   | 0    | 2     | 0 | 0                   | 0    | 1     | 2 | 0     | 7             | 114 |
| 3:00 PM                         | 0                       | 0    | 0     | 0 | 2                       | 0    | 0     | 0 | 0                   | 0    | 1     | 0 | 0                   | 0    | 4     | 2 | 0     | 9             | 116 |
| 3:05 PM                         | 0                       | 0    | 0     | 0 | 4                       | 0    | 1     | 0 | 0                   | 0    | 0     | 0 | 0                   | 0    | 5     | 5 | 0     | 15            | 126 |
| 3:10 PM                         | 0                       | 0    | 0     | 0 | 3                       | 0    | 0     | 0 | 0                   | 0    | 3     | 0 | 0                   | 0    | 1     | 2 | 0     | 9             | 124 |
| 3:15 PM                         | 0                       | 0    | 1     | 0 | 1                       | 0    | 0     | 0 | 0                   | 0    | 3     | 0 | 0                   | 0    | 2     | 1 | 0     | 8             | 121 |
| 3:20 PM                         | 0                       | 0    | 1     | 0 | 1                       | 0    | 0     | 0 | 0                   | 0    | 1     | 0 | 0                   | 1    | 1     | 3 | 0     | 8             | 117 |
| 3:25 PM                         | 0                       | 0    | 0     | 0 | 1                       | 0    | 0     | 0 | 0                   | 0    | 0     | 0 | 0                   | 1    | 9     | 0 | 0     | 11            | 117 |
| 3:30 PM                         | 0                       | 0    | 1     | 0 | 1                       | 0    | 0     | 0 | 0                   | 0    | 3     | 0 | 0                   | 2    | 5     | 2 | 0     | 14            | 125 |
| 3:35 PM                         | 0                       | 0    | 0     | 0 | 1                       | 0    | 0     | 0 | 0                   | 0    | 6     | 0 | 0                   | 1    | 5     | 2 | 0     | 15            | 122 |
| 3:40 PM                         | 0                       | 0    | 0     | 0 | 0                       | 0    | 0     | 0 | 0                   | 0    | 0     | 0 | 0                   | 1    | 2     | 0 | 0     | 3             | 117 |
| 3:45 PM                         | 0                       | 0    | 1     | 0 | 1                       | 0    | 0     | 0 | 0                   | 0    | 8     | 0 | 0                   | 0    | 3     | 1 | 0     | 14            | 120 |
| 3:50 PM                         | 0                       | 0    | 1     | 0 | 2                       | 0    | 0     | 0 | 0                   | 0    | 4     | 0 | 0                   | 2    | 1     | 1 | 0     | 11            | 124 |
| 3:55 PM                         | 0                       | 0    | 1     | 0 | 1                       | 0    | 0     | 0 | 0                   | 0    | 5     | 0 | 0                   | 2    | 2     | 2 | 0     | 13            | 130 |
| 4:00 PM                         | 0                       | 1    | 0     | 0 | 0                       | 0    | 0     | 0 | 0                   | 0    | 5     | 0 | 0                   | 0    | 5     | 3 | 0     | 14            | 135 |
| 4:05 PM                         | 0                       | 0    | 0     | 0 | 3                       | 0    | 1     | 0 | 0                   | 0    | 1     | 0 | 0                   | 0    | 2     | 0 | 0     | 7             | 127 |
| 4:10 PM                         | 0                       | 0    | 0     | 0 | 0                       | 0    | 0     | 0 | 0                   | 0    | 1     | 0 | 0                   | 4    | 0     | 2 | 1     | 8             | 126 |
| 4:15 PM                         | 0                       | 0    | 0     | 0 | 0                       | 0    | 0     | 0 | 0                   | 0    | 1     | 0 | 0                   | 1    | 3     | 1 | 0     | 6             | 124 |
| 4:20 PM                         | 0                       | 0    | 0     | 0 | 0                       | 0    | 0     | 0 | 0                   | 0    | 2     | 0 | 0                   | 0    | 3     | 0 | 0     | 5             | 121 |
| 4:25 PM                         | 0                       | 0    | 1     | 0 | 0                       | 0    | 0     | 0 | 0                   | 0    | 2     | 0 | 0                   | 1    | 2     | 0 | 0     | 6             | 116 |
| 4:30 PM                         | 0                       | 0    | 0     | 0 | 2                       | 0    | 0     | 0 | 0                   | 0    | 2     | 0 | 0                   | 2    | 3     | 1 | 0     | 10            | 112 |

## Attachment B

| 5-Min Count Period Beginning At | Reston Way (Northbound) |      |       |   | Reston Way (Southbound) |      |       |   | Main St (Eastbound) |      |       |   | Main St (Westbound) |      |       |   | Total        | Hourly Totals |     |
|---------------------------------|-------------------------|------|-------|---|-------------------------|------|-------|---|---------------------|------|-------|---|---------------------|------|-------|---|--------------|---------------|-----|
|                                 | Left                    | Thru | Right | U | Left                    | Thru | Right | U | Left                | Thru | Right | U | Left                | Thru | Right | U |              |               |     |
| 4:35 PM                         | 0                       | 0    | 0     | 0 | 2                       | 0    | 0     | 0 | 0                   | 3    | 0     | 0 | 0                   | 0    | 2     | 2 | 0            | 9             | 106 |
| 4:40 PM                         | 0                       | 0    | 1     | 0 | 0                       | 0    | 0     | 0 | 0                   | 1    | 0     | 0 | 0                   | 0    | 1     | 1 | 0            | 4             | 107 |
| 4:45 PM                         | 0                       | 0    | 2     | 0 | 3                       | 1    | 0     | 0 | 0                   | 4    | 0     | 0 | 0                   | 0    | 3     | 3 | 0            | 16            | 109 |
| 4:50 PM                         | 0                       | 0    | 1     | 0 | 1                       | 0    | 0     | 0 | 0                   | 2    | 0     | 0 | 0                   | 1    | 1     | 0 | 0            | 6             | 104 |
| 4:55 PM                         | 1                       | 0    | 0     | 0 | 4                       | 0    | 0     | 0 | 0                   | 2    | 0     | 0 | 0                   | 0    | 5     | 1 | 0            | 13            | 104 |
| 5:00 PM                         | 0                       | 0    | 1     | 0 | 0                       | 0    | 0     | 0 | 0                   | 2    | 0     | 0 | 0                   | 0    | 3     | 0 | 0            | 6             | 96  |
| 5:05 PM                         | 0                       | 0    | 1     | 0 | 1                       | 0    | 0     | 0 | 0                   | 1    | 0     | 0 | 0                   | 0    | 3     | 0 | 0            | 6             | 95  |
| 5:10 PM                         | 0                       | 0    | 1     | 0 | 1                       | 0    | 0     | 0 | 0                   | 4    | 0     | 0 | 0                   | 0    | 2     | 1 | 0            | 9             | 96  |
| 5:15 PM                         | 0                       | 0    | 2     | 0 | 2                       | 0    | 0     | 0 | 0                   | 0    | 0     | 0 | 0                   | 0    | 2     | 3 | 0            | 9             | 99  |
| 5:20 PM                         | 0                       | 0    | 0     | 0 | 1                       | 0    | 0     | 0 | 0                   | 4    | 0     | 0 | 0                   | 2    | 4     | 2 | 0            | 13            | 107 |
| 5:25 PM                         | 0                       | 0    | 0     | 0 | 0                       | 0    | 0     | 0 | 0                   | 1    | 0     | 0 | 0                   | 1    | 4     | 1 | 0            | 7             | 108 |
| 5:30 PM                         | 0                       | 0    | 2     | 0 | 3                       | 0    | 1     | 0 | 0                   | 7    | 0     | 0 | 0                   | 2    | 2     | 2 | 0            | 19            | 117 |
| 5:35 PM                         | 0                       | 0    | 0     | 0 | 1                       | 0    | 0     | 0 | 0                   | 3    | 0     | 0 | 0                   | 3    | 5     | 0 | 0            | 12            | 120 |
| 5:40 PM                         | 0                       | 0    | 0     | 0 | 1                       | 0    | 0     | 0 | 0                   | 4    | 0     | 0 | 0                   | 0    | 2     | 3 | 0            | 10            | 126 |
| 5:45 PM                         | 0                       | 0    | 0     | 0 | 2                       | 0    | 0     | 0 | 0                   | 5    | 0     | 0 | 0                   | 0    | 5     | 0 | 0            | 12            | 122 |
| 5:50 PM                         | 0                       | 0    | 2     | 0 | 2                       | 0    | 0     | 0 | 0                   | 3    | 0     | 0 | 0                   | 1    | 4     | 2 | 0            | 14            | 130 |
| 5:55 PM                         | 0                       | 0    | 0     | 0 | 1                       | 0    | 0     | 0 | 0                   | 4    | 0     | 0 | 0                   | 0    | 4     | 2 | 0            | 11            | 128 |
| 6:00 PM                         | 0                       | 0    | 0     | 0 | 0                       | 0    | 0     | 0 | 0                   | 1    | 0     | 0 | 0                   | 0    | 5     | 1 | 0            | 7             | 129 |
| 6:05 PM                         | 0                       | 0    | 0     | 0 | 0                       | 0    | 0     | 0 | 0                   | 3    | 0     | 0 | 0                   | 1    | 2     | 1 | 0            | 7             | 130 |
| 6:10 PM                         | 0                       | 0    | 1     | 0 | 0                       | 0    | 0     | 0 | 0                   | 2    | 0     | 0 | 0                   | 2    | 1     | 0 | 0            | 6             | 127 |
| 6:15 PM                         | 0                       | 0    | 0     | 0 | 1                       | 0    | 0     | 0 | 0                   | 4    | 0     | 0 | 0                   | 2    | 7     | 2 | 0            | 16            | 134 |
| 6:20 PM                         | 0                       | 0    | 0     | 0 | 1                       | 0    | 0     | 0 | 0                   | 5    | 0     | 0 | 0                   | 1    | 6     | 1 | 0            | 14            | 135 |
| 6:25 PM                         | 0                       | 0    | 0     | 0 | 1                       | 0    | 0     | 0 | 0                   | 2    | 0     | 0 | 0                   | 2    | 4     | 1 | 0            | 10            | 138 |
| 6:30 PM                         | 0                       | 0    | 0     | 0 | 0                       | 0    | 0     | 0 | 0                   | 3    | 0     | 0 | 0                   | 0    | 3     | 1 | 0            | 7             | 126 |
| 6:35 PM                         | 0                       | 0    | 1     | 0 | 0                       | 0    | 0     | 0 | 0                   | 0    | 0     | 0 | 0                   | 2    | 2     | 1 | 0            | 6             | 120 |
| 6:40 PM                         | 0                       | 0    | 2     | 0 | 2                       | 0    | 0     | 0 | 0                   | 4    | 0     | 0 | 0                   | 0    | 3     | 0 | 0            | 11            | 121 |
| 6:45 PM                         | 0                       | 0    | 2     | 0 | 1                       | 0    | 0     | 0 | 0                   | 1    | 0     | 0 | 0                   | 1    | 0     | 2 | 0            | 7             | 116 |
| 6:50 PM                         | 0                       | 0    | 0     | 0 | 0                       | 0    | 0     | 0 | 0                   | 5    | 0     | 0 | 0                   | 1    | 3     | 1 | 0            | 10            | 112 |
| 6:55 PM                         | 0                       | 0    | 0     | 0 | 2                       | 0    | 0     | 0 | 0                   | 3    | 0     | 0 | 0                   | 1    | 4     | 0 | 0            | 10            | 111 |
| 7:00 PM                         | 0                       | 0    | 2     | 0 | 0                       | 0    | 0     | 0 | 0                   | 0    | 0     | 0 | 0                   | 1    | 0     | 2 | 0            | 5             | 109 |
| 7:05 PM                         | 0                       | 0    | 1     | 0 | 1                       | 0    | 0     | 0 | 0                   | 4    | 0     | 0 | 0                   | 1    | 6     | 2 | 0            | 15            | 117 |
| 7:10 PM                         | 0                       | 0    | 2     | 0 | 1                       | 0    | 0     | 0 | 0                   | 4    | 0     | 0 | 0                   | 2    | 2     | 2 | 0            | 13            | 124 |
| 7:15 PM                         | 0                       | 0    | 0     | 0 | 0                       | 0    | 0     | 0 | 0                   | 2    | 0     | 0 | 0                   | 0    | 3     | 1 | 0            | 6             | 114 |
| 7:20 PM                         | 0                       | 0    | 0     | 0 | 2                       | 0    | 0     | 0 | 0                   | 0    | 0     | 0 | 0                   | 0    | 1     | 1 | 0            | 4             | 104 |
| 7:25 PM                         | 0                       | 0    | 1     | 0 | 0                       | 0    | 0     | 0 | 0                   | 0    | 0     | 0 | 0                   | 1    | 0     | 0 | 0            | 2             | 96  |
| 7:30 PM                         | 0                       | 0    | 0     | 0 | 0                       | 0    | 0     | 0 | 0                   | 0    | 0     | 0 | 0                   | 0    | 1     | 1 | 0            | 2             | 91  |
| 7:35 PM                         | 0                       | 0    | 1     | 0 | 2                       | 0    | 0     | 0 | 0                   | 1    | 0     | 0 | 0                   | 1    | 2     | 2 | 0            | 9             | 94  |
| 7:40 PM                         | 0                       | 0    | 2     | 0 | 0                       | 0    | 0     | 0 | 0                   | 1    | 0     | 0 | 0                   | 1    | 2     | 0 | 0            | 6             | 89  |
| 7:45 PM                         | 0                       | 0    | 0     | 0 | 0                       | 0    | 0     | 0 | 0                   | 2    | 0     | 0 | 0                   | 1    | 1     | 2 | 0            | 6             | 88  |
| 7:50 PM                         | 0                       | 0    | 0     | 0 | 0                       | 0    | 0     | 0 | 0                   | 2    | 0     | 0 | 0                   | 1    | 2     | 2 | 0            | 7             | 85  |
| 7:55 PM                         | 0                       | 0    | 1     | 0 | 0                       | 0    | 0     | 0 | 0                   | 0    | 0     | 0 | 0                   | 1    | 2     | 1 | 0            | 5             | 80  |
| 8:00 PM                         | 0                       | 0    | 0     | 0 | 0                       | 0    | 0     | 0 | 0                   | 2    | 0     | 0 | 0                   | 1    | 3     | 0 | 0            | 6             | 81  |
| 8:05 PM                         | 0                       | 0    | 0     | 0 | 0                       | 0    | 0     | 0 | 0                   | 1    | 0     | 0 | 0                   | 0    | 3     | 1 | 0            | 5             | 71  |
| 8:10 PM                         | 0                       | 0    | 1     | 0 | 1                       | 0    | 0     | 0 | 0                   | 0    | 0     | 0 | 0                   | 0    | 0     | 0 | 0            | 2             | 60  |
| 8:15 PM                         | 0                       | 0    | 0     | 0 | 1                       | 0    | 0     | 0 | 0                   | 0    | 0     | 0 | 0                   | 0    | 2     | 0 | 0            | 3             | 57  |
| 8:20 PM                         | 0                       | 0    | 2     | 0 | 0                       | 0    | 0     | 0 | 0                   | 2    | 0     | 0 | 0                   | 2    | 3     | 0 | 0            | 9             | 62  |
| 8:25 PM                         | 0                       | 0    | 0     | 0 | 0                       | 0    | 0     | 0 | 0                   | 1    | 0     | 0 | 0                   | 0    | 1     | 0 | 0            | 2             | 62  |
| 8:30 PM                         | 0                       | 0    | 0     | 0 | 0                       | 0    | 0     | 0 | 0                   | 0    | 0     | 0 | 0                   | 1    | 3     | 0 | 1            | 5             | 65  |
| 8:35 PM                         | 0                       | 0    | 1     | 0 | 0                       | 0    | 0     | 0 | 0                   | 2    | 0     | 0 | 0                   | 1    | 1     | 0 | 0            | 5             | 61  |
| 8:40 PM                         | 0                       | 0    | 0     | 0 | 0                       | 0    | 0     | 0 | 0                   | 0    | 0     | 0 | 0                   | 0    | 1     | 0 | 0            | 1             | 56  |
| 8:45 PM                         | 0                       | 0    | 0     | 0 | 0                       | 0    | 0     | 0 | 0                   | 1    | 0     | 0 | 0                   | 4    | 0     | 0 | 0            | 5             | 55  |
| 8:50 PM                         | 0                       | 0    | 0     | 0 | 0                       | 0    | 1     | 0 | 0                   | 2    | 0     | 0 | 0                   | 0    | 1     | 2 | 0            | 6             | 54  |
| 8:55 PM                         | 0                       | 0    | 0     | 0 | 1                       | 0    | 0     | 0 | 0                   | 1    | 0     | 0 | 0                   | 0    | 2     | 1 | 0            | 5             | 54  |
| 9:00 PM                         | 0                       | 0    | 0     | 0 | 0                       | 0    | 0     | 0 | 0                   | 0    | 0     | 0 | 0                   | 0    | 1     | 0 | 0            | 1             | 49  |
| 9:05 PM                         | 0                       | 0    | 0     | 0 | 1                       | 0    | 0     | 0 | 0                   | 1    | 0     | 0 | 0                   | 1    | 3     | 0 | 0            | 6             | 50  |
| 9:10 PM                         | 0                       | 0    | 0     | 0 | 0                       | 0    | 0     | 0 | 0                   | 0    | 0     | 0 | 0                   | 1    | 1     | 0 | 0            | 2             | 50  |
| 9:15 PM                         | 0                       | 0    | 1     | 0 | 1                       | 0    | 0     | 0 | 0                   | 0    | 0     | 0 | 0                   | 2    | 2     | 1 | 0            | 7             | 54  |
| 9:20 PM                         | 0                       | 0    | 0     | 0 | 0                       | 0    | 0     | 0 | 0                   | 0    | 0     | 0 | 0                   | 1    | 1     | 1 | 0            | 3             | 48  |
| 9:25 PM                         | 0                       | 0    | 1     | 0 | 0                       | 0    | 0     | 0 | 0                   | 1    | 0     | 0 | 0                   | 0    | 3     | 0 | 0            | 5             | 51  |
| 9:30 PM                         | 0                       | 0    | 0     | 0 | 0                       | 0    | 0     | 0 | 0                   | 1    | 0     | 0 | 0                   | 1    | 0     | 1 | 1            | 4             | 50  |
| 9:35 PM                         | 0                       | 0    | 0     | 0 | 0                       | 0    | 0     | 0 | 0                   | 0    | 0     | 0 | 0                   | 0    | 2     | 1 | 0            | 3             | 48  |
| 9:40 PM                         | 0                       | 0    | 0     | 0 | 0                       | 0    | 0     | 0 | 0                   | 0    | 0     | 0 | 0                   | 0    | 1     | 0 | 0            | 1             | 48  |
| 9:45 PM                         | 0                       | 0    | 0     | 0 | 0                       | 0    | 0     | 0 | 0                   | 0    | 0     | 0 | 0                   | 0    | 1     | 1 | 0            | 2             | 45  |
| 9:50 PM                         | 0                       | 0    | 0     | 0 | 0                       | 0    | 0     | 0 | 0                   | 0    | 0     | 0 | 0                   | 2    | 0     | 1 | 0            | 3             | 42  |
| 9:55 PM                         | 0                       | 0    | 1     | 0 | 1                       | 0    | 0     | 0 | 0                   | 0    | 0     | 0 | 0                   | 0    | 0     | 0 | 0            | 2             | 39  |
| <b>Peak 15-Min Flowrates</b>    | <b>Northbound</b>       |      |       |   | <b>Southbound</b>       |      |       |   | <b>Eastbound</b>    |      |       |   | <b>Westbound</b>    |      |       |   | <b>Total</b> |               |     |
|                                 | Left                    | Thru | Right | U | Left                    | Thru | Right | U | Left                | Thru | Right | U | Left                | Thru | Right | U |              |               |     |
| All Vehicles                    | 0                       | 0    | 8     | 0 | 20                      | 0    | 4     | 0 | 0                   | 56   | 0     | 0 | 20                  | 36   | 20    | 0 | 164          |               |     |
| Heavy Trucks                    | 0                       | 0    | 0     | 0 | 0                       | 0    | 0     | 0 | 0                   | 0    | 0     | 0 | 0                   | 0    | 0     | 0 | 0            | 0             |     |
| Buses                           |                         |      |       |   |                         |      |       |   |                     |      |       |   |                     |      |       |   |              |               |     |
| Pedestrians                     |                         | 16   |       |   |                         | 4    |       |   |                     | 4    |       |   |                     | 0    |       |   |              | 24            |     |
| Bicycles                        | 0                       | 0    | 0     |   | 0                       | 0    | 0     |   | 0                   | 0    | 0     |   | 0                   | 0    | 0     |   |              | 0             |     |
| Scoters                         |                         |      |       |   |                         |      |       |   |                     |      |       |   |                     |      |       |   |              |               |     |
| <i>Comments:</i>                |                         |      |       |   |                         |      |       |   |                     |      |       |   |                     |      |       |   |              |               |     |

LOCATION: Terrastar Ln -- Tether Moon Ln  
 CITY/STATE: Ladera Ranch, CA

QC JOB #: 16966459  
 DATE: Wed, Apr 16 2025

Peak-Hour: 7:20 AM -- 8:20 AM  
 Peak 15-Min: 7:55 AM -- 8:10 AM

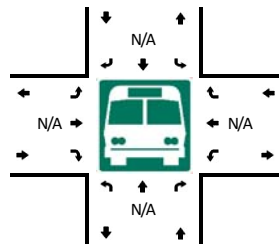
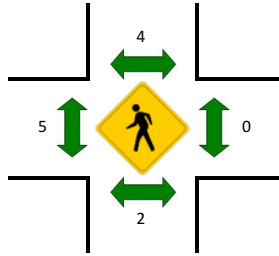
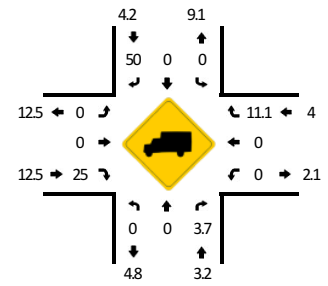
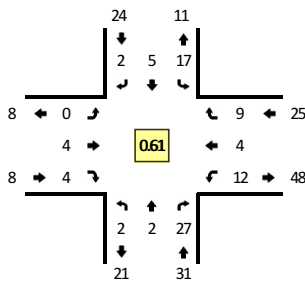

| 5-Min Count Period Beginning At | Terrastar Ln (Northbound) |      |       |   | Terrastar Ln (Southbound) |      |       |   | Tether Moon Ln (Eastbound) |      |       |   | Tether Moon Ln (Westbound) |      |       |   | Total | Hourly Totals |
|---------------------------------|---------------------------|------|-------|---|---------------------------|------|-------|---|----------------------------|------|-------|---|----------------------------|------|-------|---|-------|---------------|
|                                 | Left                      | Thru | Right | U | Left                      | Thru | Right | U | Left                       | Thru | Right | U | Left                       | Thru | Right | U |       |               |
| 6:00 AM                         | 0                         | 0    | 0     | 0 | 0                         | 0    | 0     | 0 | 0                          | 0    | 0     | 0 | 0                          | 0    | 0     | 0 | 0     | 0             |
| 6:05 AM                         | 0                         | 0    | 1     | 0 | 1                         | 0    | 0     | 0 | 0                          | 0    | 0     | 0 | 0                          | 0    | 0     | 0 | 0     | 2             |
| 6:10 AM                         | 0                         | 0    | 0     | 0 | 0                         | 0    | 0     | 0 | 0                          | 0    | 0     | 0 | 0                          | 0    | 0     | 0 | 0     | 0             |
| 6:15 AM                         | 0                         | 0    | 1     | 0 | 1                         | 0    | 0     | 0 | 0                          | 0    | 0     | 0 | 1                          | 0    | 0     | 0 | 0     | 3             |
| 6:20 AM                         | 0                         | 0    | 0     | 0 | 0                         | 0    | 0     | 0 | 0                          | 0    | 0     | 0 | 1                          | 0    | 0     | 0 | 0     | 1             |
| 6:25 AM                         | 0                         | 0    | 0     | 0 | 0                         | 0    | 0     | 0 | 0                          | 0    | 0     | 0 | 0                          | 0    | 0     | 0 | 0     | 0             |
| 6:30 AM                         | 0                         | 0    | 0     | 0 | 0                         | 0    | 0     | 0 | 0                          | 0    | 0     | 0 | 0                          | 0    | 0     | 0 | 0     | 0             |
| 6:35 AM                         | 0                         | 0    | 0     | 0 | 3                         | 0    | 0     | 0 | 0                          | 0    | 0     | 0 | 0                          | 0    | 1     | 0 | 0     | 4             |
| 6:40 AM                         | 0                         | 0    | 0     | 0 | 0                         | 0    | 0     | 0 | 0                          | 0    | 0     | 0 | 0                          | 0    | 0     | 0 | 0     | 0             |
| 6:45 AM                         | 0                         | 0    | 0     | 0 | 0                         | 0    | 0     | 0 | 0                          | 0    | 0     | 0 | 0                          | 0    | 0     | 0 | 0     | 0             |
| 6:50 AM                         | 0                         | 0    | 0     | 0 | 0                         | 0    | 0     | 0 | 0                          | 0    | 0     | 0 | 0                          | 0    | 0     | 0 | 0     | 0             |
| 6:55 AM                         | 0                         | 0    | 2     | 0 | 1                         | 0    | 0     | 0 | 0                          | 0    | 1     | 0 | 0                          | 0    | 1     | 0 | 0     | 5             |
| 7:00 AM                         | 0                         | 0    | 2     | 0 | 1                         | 1    | 0     | 0 | 0                          | 0    | 0     | 0 | 1                          | 0    | 0     | 0 | 0     | 5             |
| 7:05 AM                         | 0                         | 1    | 3     | 0 | 2                         | 0    | 0     | 0 | 0                          | 0    | 1     | 0 | 0                          | 0    | 2     | 0 | 0     | 9             |
| 7:10 AM                         | 0                         | 0    | 1     | 0 | 0                         | 0    | 0     | 0 | 0                          | 0    | 0     | 0 | 0                          | 0    | 1     | 0 | 0     | 2             |
| 7:15 AM                         | 0                         | 0    | 3     | 0 | 0                         | 0    | 0     | 0 | 0                          | 0    | 0     | 0 | 0                          | 0    | 0     | 0 | 0     | 3             |
| 7:20 AM                         | 0                         | 0    | 1     | 0 | 0                         | 0    | 0     | 0 | 0                          | 0    | 1     | 0 | 0                          | 0    | 1     | 0 | 0     | 3             |
| 7:25 AM                         | 0                         | 0    | 2     | 0 | 1                         | 0    | 0     | 0 | 0                          | 0    | 0     | 0 | 0                          | 0    | 1     | 0 | 0     | 4             |
| 7:30 AM                         | 0                         | 0    | 2     | 0 | 2                         | 1    | 0     | 0 | 0                          | 0    | 1     | 0 | 0                          | 1    | 1     | 1 | 0     | 9             |
| 7:35 AM                         | 0                         | 0    | 2     | 0 | 1                         | 0    | 0     | 0 | 0                          | 0    | 0     | 0 | 0                          | 0    | 0     | 0 | 0     | 3             |
| 7:40 AM                         | 0                         | 0    | 1     | 0 | 1                         | 2    | 0     | 0 | 0                          | 0    | 0     | 0 | 1                          | 0    | 0     | 0 | 0     | 5             |
| 7:45 AM                         | 0                         | 1    | 1     | 0 | 2                         | 1    | 0     | 0 | 0                          | 0    | 1     | 0 | 0                          | 0    | 1     | 0 | 0     | 7             |
| 7:50 AM                         | 0                         | 0    | 1     | 0 | 2                         | 0    | 0     | 0 | 0                          | 0    | 0     | 1 | 0                          | 1    | 0     | 0 | 0     | 5             |
| 7:55 AM                         | 0                         | 1    | 2     | 0 | 2                         | 0    | 0     | 0 | 0                          | 0    | 1     | 1 | 0                          | 3    | 1     | 2 | 0     | 13            |
| 8:00 AM                         | 1                         | 0    | 5     | 0 | 1                         | 1    | 2     | 0 | 0                          | 0    | 0     | 0 | 0                          | 2    | 0     | 1 | 0     | 13            |
| 8:05 AM                         | 0                         | 0    | 2     | 0 | 2                         | 0    | 0     | 0 | 0                          | 0    | 0     | 2 | 0                          | 3    | 0     | 1 | 0     | 10            |
| 8:10 AM                         | 0                         | 0    | 3     | 0 | 1                         | 0    | 0     | 0 | 0                          | 0    | 0     | 0 | 0                          | 0    | 1     | 0 | 0     | 5             |
| 8:15 AM                         | 1                         | 0    | 5     | 0 | 2                         | 0    | 0     | 0 | 0                          | 0    | 0     | 0 | 0                          | 1    | 0     | 2 | 0     | 11            |
| 8:20 AM                         | 0                         | 0    | 0     | 0 | 0                         | 0    | 0     | 0 | 0                          | 0    | 0     | 0 | 0                          | 2    | 0     | 0 | 0     | 2             |
| 8:25 AM                         | 0                         | 0    | 0     | 0 | 0                         | 0    | 0     | 1 | 0                          | 0    | 0     | 0 | 0                          | 0    | 0     | 2 | 0     | 3             |
| 8:30 AM                         | 0                         | 0    | 0     | 0 | 1                         | 0    | 0     | 0 | 0                          | 0    | 1     | 0 | 0                          | 1    | 0     | 2 | 0     | 5             |
| 8:35 AM                         | 1                         | 0    | 1     | 0 | 2                         | 0    | 0     | 0 | 0                          | 0    | 0     | 0 | 0                          | 1    | 0     | 0 | 0     | 5             |
| 8:40 AM                         | 0                         | 0    | 0     | 0 | 0                         | 1    | 0     | 0 | 0                          | 0    | 1     | 0 | 0                          | 1    | 0     | 0 | 0     | 3             |
| 8:45 AM                         | 0                         | 0    | 2     | 0 | 1                         | 0    | 0     | 0 | 0                          | 0    | 0     | 1 | 0                          | 1    | 0     | 0 | 0     | 5             |
| 8:50 AM                         | 0                         | 0    | 1     | 0 | 0                         | 0    | 0     | 0 | 0                          | 0    | 0     | 0 | 0                          | 2    | 0     | 0 | 0     | 3             |
| 8:55 AM                         | 0                         | 0    | 1     | 0 | 0                         | 0    | 0     | 0 | 0                          | 0    | 0     | 0 | 0                          | 0    | 0     | 0 | 0     | 1             |
| 9:00 AM                         | 0                         | 0    | 0     | 0 | 1                         | 0    | 0     | 0 | 0                          | 0    | 0     | 0 | 0                          | 0    | 1     | 0 | 0     | 2             |
| 9:05 AM                         | 0                         | 0    | 0     | 0 | 1                         | 0    | 0     | 0 | 0                          | 0    | 1     | 0 | 0                          | 0    | 0     | 0 | 0     | 2             |

# Attachment B

| 5-Min Count<br>Period<br>Beginning At | Terrastar Ln<br>(Northbound) |      |       |   | Terrastar Ln<br>(Southbound) |      |       |   | Tether Moon Ln<br>(Eastbound) |      |       |   | Tether Moon Ln<br>(Westbound) |      |       |   | Total | Hourly<br>Totals |
|---------------------------------------|------------------------------|------|-------|---|------------------------------|------|-------|---|-------------------------------|------|-------|---|-------------------------------|------|-------|---|-------|------------------|
|                                       | Left                         | Thru | Right | U | Left                         | Thru | Right | U | Left                          | Thru | Right | U | Left                          | Thru | Right | U |       |                  |
| 9:10 AM                               | 0                            | 0    | 0     | 0 | 1                            | 0    | 0     | 0 | 0                             | 0    | 0     | 0 | 1                             | 0    | 0     | 0 | 2     | 44               |
| 9:15 AM                               | 0                            | 0    | 2     | 0 | 1                            | 0    | 0     | 0 | 0                             | 0    | 1     | 0 | 0                             | 0    | 0     | 0 | 4     | 37               |
| 9:20 AM                               | 0                            | 0    | 0     | 0 | 1                            | 0    | 0     | 0 | 0                             | 0    | 0     | 0 | 1                             | 0    | 1     | 0 | 3     | 38               |
| 9:25 AM                               | 0                            | 0    | 0     | 0 | 1                            | 0    | 0     | 0 | 0                             | 0    | 0     | 0 | 1                             | 1    | 0     | 0 | 3     | 38               |
| 9:30 AM                               | 0                            | 0    | 0     | 0 | 0                            | 0    | 0     | 0 | 0                             | 0    | 1     | 0 | 1                             | 0    | 1     | 0 | 3     | 36               |
| 9:35 AM                               | 0                            | 0    | 0     | 0 | 0                            | 0    | 0     | 0 | 0                             | 0    | 0     | 0 | 0                             | 2    | 0     | 0 | 2     | 33               |
| 9:40 AM                               | 0                            | 0    | 0     | 0 | 0                            | 0    | 0     | 0 | 0                             | 0    | 0     | 0 | 0                             | 0    | 0     | 0 | 0     | 30               |
| 9:45 AM                               | 0                            | 0    | 1     | 0 | 1                            | 0    | 0     | 0 | 0                             | 0    | 0     | 0 | 0                             | 0    | 0     | 0 | 2     | 27               |
| 9:50 AM                               | 0                            | 0    | 0     | 0 | 0                            | 0    | 0     | 0 | 0                             | 0    | 0     | 0 | 1                             | 0    | 0     | 0 | 1     | 25               |
| 9:55 AM                               | 0                            | 0    | 0     | 0 | 0                            | 0    | 0     | 0 | 0                             | 0    | 0     | 0 | 0                             | 2    | 0     | 0 | 2     | 26               |
| 10:00 AM                              | 0                            | 0    | 1     | 0 | 1                            | 0    | 1     | 0 | 0                             | 0    | 0     | 1 | 2                             | 1    | 0     | 0 | 7     | 31               |
| 10:05 AM                              | 0                            | 0    | 1     | 0 | 1                            | 0    | 0     | 0 | 0                             | 0    | 0     | 0 | 0                             | 0    | 0     | 0 | 2     | 31               |
| 10:10 AM                              | 0                            | 0    | 1     | 0 | 1                            | 0    | 0     | 0 | 0                             | 0    | 0     | 0 | 0                             | 0    | 2     | 0 | 4     | 33               |
| 10:15 AM                              | 0                            | 0    | 0     | 0 | 0                            | 0    | 0     | 0 | 0                             | 0    | 0     | 0 | 0                             | 0    | 1     | 0 | 1     | 30               |
| 10:20 AM                              | 0                            | 0    | 1     | 0 | 1                            | 0    | 0     | 0 | 0                             | 0    | 1     | 0 | 0                             | 0    | 1     | 0 | 4     | 31               |
| 10:25 AM                              | 0                            | 0    | 0     | 0 | 2                            | 0    | 0     | 0 | 0                             | 0    | 0     | 0 | 0                             | 0    | 0     | 0 | 2     | 30               |
| 10:30 AM                              | 0                            | 0    | 1     | 0 | 0                            | 0    | 1     | 0 | 0                             | 0    | 0     | 0 | 1                             | 1    | 1     | 0 | 5     | 32               |
| 10:35 AM                              | 0                            | 1    | 2     | 0 | 0                            | 0    | 0     | 0 | 0                             | 0    | 0     | 1 | 0                             | 1    | 2     | 0 | 7     | 37               |
| 10:40 AM                              | 0                            | 0    | 0     | 0 | 2                            | 1    | 0     | 0 | 0                             | 1    | 0     | 0 | 0                             | 0    | 1     | 0 | 5     | 42               |
| 10:45 AM                              | 0                            | 0    | 1     | 0 | 0                            | 0    | 0     | 0 | 0                             | 0    | 0     | 0 | 0                             | 0    | 0     | 0 | 1     | 41               |
| 10:50 AM                              | 0                            | 0    | 0     | 0 | 0                            | 0    | 0     | 0 | 0                             | 0    | 0     | 0 | 0                             | 2    | 0     | 0 | 2     | 42               |
| 10:55 AM                              | 0                            | 0    | 0     | 0 | 1                            | 0    | 0     | 0 | 0                             | 0    | 1     | 0 | 0                             | 1    | 0     | 0 | 3     | 43               |
| 11:00 AM                              | 0                            | 1    | 1     | 0 | 2                            | 0    | 0     | 0 | 0                             | 0    | 0     | 0 | 1                             | 1    | 0     | 0 | 6     | 42               |
| 11:05 AM                              | 0                            | 0    | 0     | 0 | 1                            | 0    | 0     | 0 | 0                             | 0    | 0     | 0 | 2                             | 0    | 0     | 0 | 3     | 43               |
| 11:10 AM                              | 0                            | 0    | 1     | 0 | 1                            | 0    | 0     | 0 | 0                             | 0    | 0     | 0 | 0                             | 0    | 1     | 0 | 3     | 42               |
| 11:15 AM                              | 0                            | 0    | 0     | 0 | 1                            | 0    | 0     | 0 | 0                             | 0    | 0     | 1 | 0                             | 0    | 0     | 0 | 3     | 44               |
| 11:20 AM                              | 0                            | 0    | 1     | 0 | 0                            | 0    | 0     | 0 | 0                             | 0    | 0     | 0 | 3                             | 1    | 0     | 0 | 5     | 45               |
| 11:25 AM                              | 0                            | 0    | 0     | 0 | 1                            | 0    | 0     | 0 | 0                             | 0    | 0     | 0 | 0                             | 0    | 2     | 0 | 3     | 46               |
| 11:30 AM                              | 0                            | 0    | 0     | 0 | 0                            | 0    | 0     | 0 | 0                             | 0    | 1     | 0 | 1                             | 0    | 0     | 0 | 2     | 43               |
| 11:35 AM                              | 0                            | 0    | 1     | 0 | 4                            | 0    | 0     | 0 | 0                             | 0    | 0     | 0 | 0                             | 0    | 3     | 0 | 8     | 44               |
| 11:40 AM                              | 0                            | 0    | 1     | 0 | 1                            | 0    | 0     | 0 | 0                             | 0    | 0     | 0 | 0                             | 0    | 1     | 0 | 3     | 42               |
| 11:45 AM                              | 0                            | 0    | 2     | 0 | 1                            | 0    | 0     | 0 | 0                             | 0    | 0     | 0 | 1                             | 0    | 0     | 0 | 4     | 45               |
| 11:50 AM                              | 0                            | 1    | 0     | 0 | 1                            | 0    | 0     | 0 | 0                             | 0    | 0     | 0 | 0                             | 0    | 0     | 0 | 2     | 45               |
| 11:55 AM                              | 1                            | 0    | 0     | 0 | 1                            | 0    | 0     | 0 | 0                             | 0    | 1     | 0 | 1                             | 0    | 2     | 0 | 6     | 48               |
| 12:00 PM                              | 0                            | 0    | 2     | 0 | 1                            | 1    | 0     | 0 | 0                             | 1    | 0     | 0 | 0                             | 1    | 0     | 0 | 6     | 48               |
| 12:05 PM                              | 0                            | 0    | 0     | 0 | 2                            | 0    | 0     | 0 | 0                             | 0    | 0     | 0 | 0                             | 0    | 2     | 0 | 4     | 49               |
| 12:10 PM                              | 0                            | 0    | 0     | 0 | 0                            | 0    | 0     | 0 | 0                             | 0    | 1     | 0 | 2                             | 0    | 0     | 0 | 3     | 49               |
| 12:15 PM                              | 0                            | 0    | 0     | 0 | 1                            | 0    | 0     | 0 | 0                             | 0    | 0     | 0 | 1                             | 0    | 3     | 0 | 5     | 51               |
| 12:20 PM                              | 0                            | 0    | 0     | 0 | 0                            | 0    | 0     | 0 | 0                             | 0    | 0     | 0 | 2                             | 1    | 0     | 0 | 3     | 49               |
| 12:25 PM                              | 0                            | 0    | 1     | 0 | 0                            | 0    | 0     | 0 | 0                             | 0    | 0     | 0 | 0                             | 0    | 1     | 0 | 2     | 48               |
| 12:30 PM                              | 0                            | 0    | 1     | 0 | 0                            | 0    | 0     | 0 | 0                             | 0    | 0     | 0 | 0                             | 0    | 1     | 0 | 2     | 48               |
| 12:35 PM                              | 0                            | 0    | 0     | 0 | 0                            | 0    | 0     | 0 | 0                             | 0    | 1     | 0 | 0                             | 1    | 0     | 0 | 2     | 42               |
| 12:40 PM                              | 0                            | 0    | 0     | 0 | 0                            | 0    | 0     | 0 | 0                             | 0    | 0     | 0 | 1                             | 1    | 0     | 0 | 2     | 41               |
| 12:45 PM                              | 0                            | 0    | 0     | 0 | 1                            | 1    | 0     | 0 | 0                             | 0    | 0     | 0 | 1                             | 0    | 1     | 0 | 4     | 41               |
| 12:50 PM                              | 0                            | 0    | 0     | 0 | 0                            | 0    | 0     | 0 | 0                             | 0    | 1     | 0 | 2                             | 0    | 1     | 0 | 4     | 43               |
| 12:55 PM                              | 0                            | 0    | 1     | 0 | 0                            | 1    | 0     | 0 | 0                             | 0    | 0     | 0 | 1                             | 0    | 0     | 0 | 3     | 40               |
| 1:00 PM                               | 0                            | 1    | 1     | 0 | 0                            | 0    | 0     | 0 | 0                             | 0    | 1     | 0 | 2                             | 1    | 0     | 0 | 6     | 40               |
| 1:05 PM                               | 0                            | 0    | 1     | 0 | 0                            | 1    | 0     | 0 | 0                             | 0    | 0     | 0 | 0                             | 0    | 2     | 0 | 4     | 40               |
| 1:10 PM                               | 0                            | 1    | 0     | 0 | 1                            | 0    | 0     | 0 | 0                             | 0    | 0     | 0 | 1                             | 0    | 0     | 0 | 3     | 40               |
| 1:15 PM                               | 0                            | 0    | 1     | 0 | 2                            | 0    | 0     | 0 | 0                             | 0    | 0     | 0 | 1                             | 0    | 0     | 0 | 4     | 39               |
| 1:20 PM                               | 1                            | 0    | 1     | 0 | 0                            | 0    | 0     | 0 | 0                             | 0    | 0     | 0 | 0                             | 0    | 0     | 0 | 2     | 38               |
| 1:25 PM                               | 0                            | 0    | 0     | 0 | 3                            | 0    | 0     | 0 | 0                             | 0    | 1     | 0 | 0                             | 0    | 2     | 0 | 6     | 42               |
| 1:30 PM                               | 0                            | 0    | 1     | 0 | 0                            | 0    | 0     | 0 | 0                             | 0    | 0     | 1 | 1                             | 0    | 0     | 0 | 3     | 43               |
| 1:35 PM                               | 0                            | 0    | 3     | 0 | 0                            | 0    | 0     | 0 | 0                             | 0    | 0     | 0 | 0                             | 1    | 1     | 0 | 5     | 46               |
| 1:40 PM                               | 0                            | 0    | 0     | 0 | 0                            | 0    | 0     | 0 | 0                             | 0    | 0     | 0 | 0                             | 0    | 0     | 0 | 0     | 44               |
| 1:45 PM                               | 0                            | 0    | 0     | 0 | 0                            | 0    | 0     | 0 | 0                             | 0    | 0     | 0 | 0                             | 0    | 0     | 0 | 0     | 40               |
| 1:50 PM                               | 0                            | 0    | 0     | 0 | 0                            | 0    | 0     | 0 | 0                             | 0    | 0     | 0 | 1                             | 0    | 0     | 0 | 1     | 37               |
| 1:55 PM                               | 0                            | 0    | 1     | 0 | 1                            | 0    | 0     | 0 | 0                             | 0    | 0     | 0 | 0                             | 0    | 0     | 0 | 2     | 36               |
| 2:00 PM                               | 0                            | 0    | 1     | 0 | 1                            | 0    | 0     | 0 | 0                             | 0    | 1     | 0 | 1                             | 0    | 0     | 0 | 3     | 33               |
| 2:05 PM                               | 0                            | 0    | 0     | 0 | 0                            | 0    | 0     | 0 | 0                             | 0    | 1     | 0 | 0                             | 0    | 0     | 0 | 1     | 30               |
| 2:10 PM                               | 0                            | 0    | 0     | 0 | 0                            | 0    | 0     | 0 | 0                             | 0    | 0     | 0 | 0                             | 0    | 1     | 0 | 1     | 28               |
| 2:15 PM                               | 0                            | 0    | 4     | 0 | 2                            | 0    | 1     | 0 | 1                             | 0    | 0     | 0 | 1                             | 0    | 2     | 0 | 11    | 35               |
| 2:20 PM                               | 0                            | 0    | 0     | 0 | 0                            | 0    | 0     | 0 | 0                             | 0    | 1     | 0 | 1                             | 0    | 2     | 0 | 4     | 37               |
| 2:25 PM                               | 0                            | 0    | 1     | 0 | 0                            | 0    | 0     | 0 | 0                             | 0    | 0     | 0 | 1                             | 0    | 0     | 0 | 2     | 33               |
| 2:30 PM                               | 0                            | 1    | 1     | 0 | 2                            | 0    | 0     | 0 | 0                             | 0    | 0     | 0 | 1                             | 0    | 0     | 0 | 5     | 35               |
| 2:35 PM                               | 0                            | 0    | 1     | 0 | 0                            | 0    | 0     | 0 | 0                             | 0    | 0     | 0 | 1                             | 0    | 0     | 0 | 2     | 32               |
| 2:40 PM                               | 0                            | 0    | 2     | 0 | 2                            | 0    | 0     | 0 | 0                             | 0    | 0     | 0 | 2                             | 0    | 1     | 0 | 7     | 39               |
| 2:45 PM                               | 0                            | 0    | 2     | 0 | 1                            | 0    | 0     | 0 | 1                             | 0    | 0     | 0 | 7                             | 1    | 2     | 0 | 14    | 53               |
| 2:50 PM                               | 0                            | 0    | 0     | 0 | 2                            | 0    | 0     | 0 | 0                             | 0    | 0     | 0 | 2                             | 0    | 0     | 0 | 4     | 56               |
| 2:55 PM                               | 0                            | 0    | 4     | 0 | 0                            | 0    | 0     | 0 | 0                             | 0    | 0     | 0 | 4                             | 0    | 0     | 0 | 8     | 62               |
| 3:00 PM                               | 0                            | 1    | 4     | 0 | 1                            | 0    | 0     | 0 | 0                             | 0    | 0     | 0 | 0                             | 0    | 0     | 0 | 6     | 65               |
| 3:05 PM                               | 0                            | 1    | 2     | 0 | 2                            | 0    | 0     | 0 | 0                             | 0    | 0     | 0 | 2                             | 0    | 1     | 0 | 8     | 72               |
| 3:10 PM                               | 0                            | 0    | 1     | 0 | 1                            | 0    | 0     | 0 | 0                             | 0    | 0     | 0 | 4                             | 0    | 1     | 0 | 7     | 78               |
| 3:15 PM                               | 0                            | 0    | 0     | 0 | 2                            | 0    | 0     | 0 | 0                             | 0    | 0     | 0 | 0                             | 1    | 0     | 0 | 3     | 70               |
| 3:20 PM                               | 0                            | 0    | 0     | 0 | 0                            | 0    | 0     | 0 | 0                             | 0    | 0     | 0 | 1                             | 1    | 1     | 0 | 3     | 69               |
| 3:25 PM                               | 0                            | 0    | 1     | 0 | 2                            | 0    | 0     | 0 | 0                             | 0    | 0     | 0 | 1                             | 0    | 2     | 0 | 6     | 73               |
| 3:30 PM                               | 0                            | 0    | 0     | 0 | 1                            | 0    | 0     | 0 | 0                             | 0    | 0     | 0 | 1                             | 0    | 0     | 0 | 2     | 70               |
| 3:35 PM                               | 0                            | 1    | 0     | 0 | 2                            | 1    | 0     | 0 | 0                             | 0    | 0     | 0 | 2                             | 1    | 1     | 0 | 8     | 76               |
| 3:40 PM                               | 0                            | 0    | 1     | 0 | 2                            | 0    | 0     | 0 | 0                             | 0    | 0     | 0 | 3                             | 0    | 1     | 0 | 7     | 76               |
| 3:45 PM                               | 0                            | 0    | 1     | 0 | 2                            | 0    | 0     | 0 | 0                             | 0    | 1     | 0 | 1                             | 0    | 2     | 0 | 7     | 69               |
| 3:50 PM                               | 0                            | 0    | 0     | 0 | 3                            | 0    | 0     | 0 | 0                             | 0    | 0     | 0 | 0                             | 0    | 1     | 0 | 4     | 69               |
| 3:55 PM                               | 0                            | 0    | 0     | 0 | 0                            | 0    | 0     | 0 | 0                             | 0    | 0     | 0 | 0                             | 0    | 1     | 0 | 1     | 62               |
| 4:00 PM                               | 0                            | 0    | 0     | 0 | 0                            | 0    | 0     | 0 | 1                             | 0    | 0     | 0 | 0                             | 1    | 0     | 0 | 2     | 58               |
| 4:05 PM                               | 0                            | 0    | 0     | 0 | 0                            | 0    | 0     | 0 | 0                             | 2    | 0     | 0 | 2                             | 1    | 0     | 0 | 5     | 55               |
| 4:10 PM                               | 0                            | 0    | 2     | 0 | 1                            | 0    | 0     | 0 | 0                             | 0    | 0     | 0 | 2                             | 0    | 1     | 0 | 6     | 54               |
| 4:15 PM                               | 0                            | 0    | 1     | 0 | 1                            | 1    | 0     | 0 | 0                             | 0    | 1     | 0 | 2                             | 0    | 0     | 0 | 6     | 57               |
| 4:20 PM                               | 0                            | 0    | 3     | 0 | 0                            | 1    | 0     | 0 | 0                             | 0    | 0     | 0 | 3                             | 3    | 1     | 0 | 11    | 65               |
| 4:25 PM                               | 0                            | 0    | 0     | 0 | 0                            | 0    | 0     | 0 | 0                             | 1    | 0     | 0 | 0                             | 1    | 0     | 0 | 2     | 61               |
| 4:30 PM                               | 0                            | 0    | 0     | 0 | 0                            | 0    | 0     | 0 | 0                             | 1    | 0     | 0 | 0                             | 1    | 0     | 0 | 2     | 61               |

## Attachment B

| 5-Min Count Period Beginning At | Terrastar Ln (Northbound) |      |       |   | Terrastar Ln (Southbound) |      |       |   | Tether Moon Ln (Eastbound) |      |       |   | Tether Moon Ln (Westbound) |      |       |   | Total | Hourly Totals |    |
|---------------------------------|---------------------------|------|-------|---|---------------------------|------|-------|---|----------------------------|------|-------|---|----------------------------|------|-------|---|-------|---------------|----|
|                                 | Left                      | Thru | Right | U | Left                      | Thru | Right | U | Left                       | Thru | Right | U | Left                       | Thru | Right | U |       |               |    |
| 4:35 PM                         | 0                         | 0    | 2     | 0 | 1                         | 0    | 0     | 0 | 0                          | 1    | 0     | 0 | 0                          | 2    | 1     | 1 | 0     | 8             | 61 |
| 4:40 PM                         | 0                         | 0    | 1     | 0 | 0                         | 0    | 0     | 0 | 0                          | 0    | 1     | 0 | 0                          | 0    | 0     | 0 | 0     | 2             | 56 |
| 4:45 PM                         | 0                         | 0    | 3     | 0 | 0                         | 0    | 0     | 0 | 0                          | 0    | 1     | 0 | 0                          | 0    | 0     | 0 | 0     | 4             | 53 |
| 4:50 PM                         | 0                         | 0    | 1     | 0 | 0                         | 1    | 0     | 0 | 0                          | 0    | 0     | 0 | 0                          | 1    | 0     | 1 | 0     | 4             | 53 |
| 4:55 PM                         | 0                         | 0    | 0     | 0 | 0                         | 0    | 0     | 0 | 0                          | 0    | 0     | 0 | 0                          | 2    | 0     | 0 | 0     | 2             | 54 |
| 5:00 PM                         | 0                         | 0    | 0     | 0 | 0                         | 0    | 0     | 0 | 0                          | 0    | 1     | 0 | 0                          | 2    | 0     | 1 | 0     | 4             | 56 |
| 5:05 PM                         | 0                         | 0    | 1     | 0 | 1                         | 0    | 0     | 0 | 0                          | 0    | 1     | 0 | 0                          | 0    | 0     | 2 | 0     | 5             | 56 |
| 5:10 PM                         | 0                         | 0    | 0     | 0 | 1                         | 1    | 0     | 0 | 0                          | 0    | 0     | 0 | 0                          | 1    | 0     | 0 | 0     | 3             | 53 |
| 5:15 PM                         | 0                         | 0    | 0     | 0 | 0                         | 0    | 0     | 0 | 0                          | 0    | 0     | 0 | 0                          | 1    | 0     | 1 | 0     | 2             | 49 |
| 5:20 PM                         | 0                         | 0    | 1     | 0 | 1                         | 0    | 0     | 0 | 0                          | 0    | 0     | 0 | 0                          | 1    | 0     | 1 | 0     | 4             | 42 |
| 5:25 PM                         | 0                         | 0    | 1     | 0 | 0                         | 0    | 0     | 0 | 0                          | 0    | 0     | 0 | 0                          | 0    | 0     | 1 | 0     | 2             | 42 |
| 5:30 PM                         | 0                         | 0    | 1     | 0 | 0                         | 0    | 0     | 0 | 0                          | 0    | 0     | 0 | 0                          | 2    | 0     | 1 | 0     | 4             | 44 |
| 5:35 PM                         | 0                         | 0    | 0     | 0 | 3                         | 0    | 0     | 0 | 0                          | 0    | 0     | 0 | 0                          | 0    | 0     | 0 | 0     | 3             | 39 |
| 5:40 PM                         | 0                         | 0    | 0     | 0 | 0                         | 0    | 0     | 0 | 0                          | 0    | 0     | 0 | 0                          | 0    | 1     | 2 | 0     | 3             | 40 |
| 5:45 PM                         | 0                         | 0    | 1     | 0 | 1                         | 0    | 0     | 0 | 0                          | 0    | 0     | 0 | 0                          | 2    | 0     | 0 | 0     | 4             | 40 |
| 5:50 PM                         | 0                         | 0    | 2     | 0 | 0                         | 0    | 0     | 0 | 0                          | 0    | 0     | 0 | 0                          | 1    | 0     | 0 | 0     | 3             | 39 |
| 5:55 PM                         | 0                         | 1    | 0     | 0 | 0                         | 1    | 0     | 0 | 0                          | 0    | 0     | 0 | 0                          | 0    | 0     | 4 | 0     | 6             | 43 |
| 6:00 PM                         | 0                         | 0    | 1     | 0 | 1                         | 0    | 0     | 0 | 0                          | 0    | 0     | 0 | 0                          | 1    | 0     | 3 | 0     | 6             | 45 |
| 6:05 PM                         | 0                         | 0    | 0     | 0 | 0                         | 0    | 0     | 0 | 0                          | 0    | 0     | 0 | 0                          | 0    | 0     | 1 | 0     | 1             | 41 |
| 6:10 PM                         | 0                         | 0    | 1     | 0 | 0                         | 0    | 0     | 0 | 0                          | 0    | 0     | 0 | 0                          | 1    | 0     | 0 | 0     | 2             | 40 |
| 6:15 PM                         | 0                         | 0    | 0     | 0 | 2                         | 0    | 0     | 0 | 0                          | 0    | 0     | 0 | 0                          | 4    | 0     | 2 | 0     | 8             | 46 |
| 6:20 PM                         | 0                         | 0    | 0     | 0 | 0                         | 0    | 0     | 0 | 0                          | 0    | 0     | 0 | 0                          | 0    | 2     | 1 | 0     | 3             | 45 |
| 6:25 PM                         | 0                         | 0    | 0     | 0 | 1                         | 0    | 0     | 0 | 0                          | 0    | 1     | 0 | 0                          | 1    | 0     | 0 | 0     | 3             | 46 |
| 6:30 PM                         | 0                         | 1    | 2     | 0 | 1                         | 0    | 0     | 0 | 0                          | 0    | 0     | 0 | 0                          | 1    | 0     | 1 | 0     | 6             | 48 |
| 6:35 PM                         | 0                         | 0    | 1     | 0 | 1                         | 1    | 0     | 0 | 0                          | 0    | 0     | 0 | 0                          | 1    | 2     | 4 | 0     | 10            | 55 |
| 6:40 PM                         | 0                         | 0    | 0     | 0 | 1                         | 1    | 0     | 0 | 0                          | 0    | 1     | 0 | 0                          | 0    | 0     | 2 | 0     | 5             | 57 |
| 6:45 PM                         | 0                         | 0    | 1     | 0 | 1                         | 0    | 0     | 0 | 0                          | 0    | 0     | 0 | 0                          | 0    | 1     | 2 | 0     | 5             | 58 |
| 6:50 PM                         | 0                         | 1    | 0     | 0 | 0                         | 0    | 0     | 0 | 0                          | 0    | 0     | 0 | 0                          | 0    | 0     | 2 | 0     | 3             | 58 |
| 6:55 PM                         | 0                         | 0    | 1     | 0 | 0                         | 1    | 0     | 0 | 0                          | 0    | 0     | 0 | 0                          | 1    | 0     | 0 | 0     | 3             | 55 |
| 7:00 PM                         | 0                         | 0    | 0     | 0 | 1                         | 0    | 0     | 0 | 0                          | 0    | 0     | 0 | 0                          | 1    | 1     | 0 | 0     | 3             | 52 |
| 7:05 PM                         | 0                         | 1    | 1     | 0 | 0                         | 1    | 0     | 0 | 0                          | 0    | 0     | 0 | 0                          | 0    | 0     | 0 | 0     | 3             | 54 |
| 7:10 PM                         | 0                         | 0    | 0     | 0 | 0                         | 0    | 0     | 0 | 0                          | 0    | 0     | 0 | 0                          | 1    | 0     | 1 | 0     | 2             | 54 |
| 7:15 PM                         | 0                         | 0    | 1     | 0 | 2                         | 0    | 0     | 0 | 0                          | 0    | 0     | 0 | 0                          | 1    | 0     | 1 | 0     | 5             | 51 |
| 7:20 PM                         | 0                         | 0    | 1     | 0 | 0                         | 0    | 0     | 0 | 0                          | 0    | 0     | 0 | 0                          | 0    | 0     | 0 | 0     | 1             | 49 |
| 7:25 PM                         | 0                         | 0    | 0     | 0 | 0                         | 0    | 0     | 0 | 0                          | 0    | 0     | 0 | 0                          | 1    | 0     | 0 | 0     | 1             | 47 |
| 7:30 PM                         | 0                         | 0    | 0     | 0 | 0                         | 0    | 0     | 0 | 0                          | 0    | 0     | 0 | 0                          | 0    | 0     | 0 | 0     | 0             | 41 |
| 7:35 PM                         | 0                         | 0    | 1     | 0 | 1                         | 0    | 0     | 0 | 0                          | 0    | 1     | 0 | 0                          | 1    | 0     | 2 | 0     | 6             | 37 |
| 7:40 PM                         | 0                         | 0    | 0     | 0 | 0                         | 0    | 0     | 0 | 0                          | 0    | 0     | 0 | 0                          | 2    | 1     | 2 | 0     | 5             | 37 |
| 7:45 PM                         | 0                         | 0    | 0     | 0 | 0                         | 1    | 0     | 0 | 0                          | 0    | 0     | 0 | 0                          | 3    | 0     | 1 | 0     | 5             | 37 |
| 7:50 PM                         | 0                         | 0    | 1     | 0 | 0                         | 0    | 0     | 0 | 0                          | 0    | 0     | 0 | 0                          | 0    | 0     | 0 | 0     | 1             | 35 |
| 7:55 PM                         | 0                         | 0    | 2     | 0 | 0                         | 0    | 0     | 0 | 0                          | 0    | 0     | 0 | 0                          | 1    | 0     | 3 | 0     | 6             | 38 |
| 8:00 PM                         | 0                         | 0    | 0     | 0 | 0                         | 0    | 0     | 0 | 0                          | 0    | 0     | 0 | 0                          | 3    | 1     | 0 | 0     | 4             | 39 |
| 8:05 PM                         | 0                         | 0    | 1     | 0 | 1                         | 0    | 0     | 0 | 0                          | 0    | 1     | 0 | 0                          | 0    | 0     | 0 | 0     | 3             | 39 |
| 8:10 PM                         | 0                         | 0    | 0     | 0 | 1                         | 0    | 0     | 0 | 0                          | 0    | 0     | 0 | 0                          | 2    | 0     | 1 | 0     | 4             | 41 |
| 8:15 PM                         | 0                         | 0    | 1     | 0 | 0                         | 0    | 0     | 0 | 0                          | 0    | 1     | 0 | 0                          | 1    | 1     | 0 | 0     | 4             | 40 |
| 8:20 PM                         | 0                         | 0    | 0     | 0 | 0                         | 0    | 0     | 0 | 0                          | 0    | 0     | 0 | 0                          | 0    | 0     | 0 | 0     | 0             | 39 |
| 8:25 PM                         | 0                         | 0    | 0     | 0 | 0                         | 0    | 0     | 0 | 0                          | 0    | 0     | 0 | 0                          | 1    | 0     | 1 | 0     | 2             | 40 |
| 8:30 PM                         | 0                         | 0    | 0     | 0 | 0                         | 0    | 0     | 0 | 0                          | 0    | 0     | 0 | 0                          | 0    | 1     | 2 | 0     | 3             | 43 |
| 8:35 PM                         | 0                         | 0    | 0     | 0 | 0                         | 0    | 0     | 0 | 0                          | 0    | 0     | 0 | 0                          | 1    | 0     | 1 | 0     | 2             | 39 |
| 8:40 PM                         | 0                         | 0    | 1     | 0 | 1                         | 0    | 0     | 0 | 0                          | 0    | 0     | 0 | 0                          | 0    | 0     | 1 | 0     | 3             | 37 |
| 8:45 PM                         | 0                         | 0    | 0     | 0 | 0                         | 0    | 0     | 0 | 0                          | 0    | 0     | 0 | 0                          | 0    | 0     | 0 | 0     | 0             | 32 |
| 8:50 PM                         | 0                         | 0    | 0     | 0 | 0                         | 0    | 0     | 0 | 0                          | 0    | 0     | 0 | 0                          | 1    | 1     | 0 | 0     | 2             | 33 |
| 8:55 PM                         | 0                         | 0    | 0     | 0 | 2                         | 0    | 0     | 0 | 0                          | 0    | 0     | 0 | 0                          | 0    | 0     | 1 | 0     | 3             | 30 |
| 9:00 PM                         | 0                         | 0    | 0     | 0 | 0                         | 0    | 0     | 0 | 0                          | 0    | 0     | 0 | 0                          | 0    | 0     | 0 | 0     | 0             | 26 |
| 9:05 PM                         | 0                         | 0    | 0     | 0 | 0                         | 0    | 0     | 0 | 0                          | 0    | 0     | 0 | 0                          | 0    | 0     | 0 | 0     | 0             | 23 |
| 9:10 PM                         | 0                         | 1    | 0     | 0 | 2                         | 0    | 0     | 0 | 0                          | 0    | 0     | 0 | 0                          | 0    | 0     | 0 | 0     | 3             | 22 |
| 9:15 PM                         | 0                         | 0    | 0     | 0 | 0                         | 0    | 0     | 0 | 0                          | 0    | 0     | 0 | 0                          | 0    | 0     | 0 | 0     | 0             | 18 |
| 9:20 PM                         | 0                         | 0    | 0     | 0 | 0                         | 0    | 0     | 0 | 0                          | 0    | 0     | 0 | 0                          | 1    | 0     | 0 | 0     | 1             | 19 |
| 9:25 PM                         | 0                         | 0    | 0     | 0 | 0                         | 0    | 0     | 0 | 0                          | 0    | 0     | 0 | 0                          | 2    | 0     | 0 | 0     | 2             | 19 |
| 9:30 PM                         | 0                         | 0    | 0     | 0 | 0                         | 0    | 0     | 0 | 0                          | 0    | 0     | 0 | 0                          | 0    | 0     | 1 | 0     | 1             | 17 |
| 9:35 PM                         | 0                         | 0    | 0     | 0 | 1                         | 0    | 0     | 0 | 0                          | 0    | 0     | 0 | 0                          | 1    | 1     | 0 | 0     | 3             | 18 |
| 9:40 PM                         | 0                         | 0    | 0     | 0 | 0                         | 0    | 0     | 0 | 0                          | 0    | 0     | 0 | 0                          | 0    | 0     | 0 | 0     | 0             | 15 |
| 9:45 PM                         | 0                         | 0    | 0     | 0 | 1                         | 0    | 0     | 0 | 0                          | 0    | 0     | 0 | 0                          | 0    | 0     | 1 | 0     | 2             | 17 |
| 9:50 PM                         | 0                         | 0    | 0     | 0 | 0                         | 0    | 0     | 0 | 0                          | 0    | 0     | 0 | 0                          | 0    | 0     | 0 | 0     | 0             | 15 |
| 9:55 PM                         | 0                         | 0    | 0     | 0 | 0                         | 0    | 0     | 0 | 0                          | 0    | 0     | 0 | 0                          | 1    | 0     | 0 | 0     | 1             | 13 |
| Peak 15-Min Flowrates           | Northbound                |      |       |   | Southbound                |      |       |   | Eastbound                  |      |       |   | Westbound                  |      |       |   | Total |               |    |
|                                 | Left                      | Thru | Right | U | Left                      | Thru | Right | U | Left                       | Thru | Right | U | Left                       | Thru | Right | U |       |               |    |
| All Vehicles                    | 4                         | 4    | 36    | 0 | 20                        | 4    | 8     | 0 | 0                          | 4    | 12    | 0 | 32                         | 4    | 16    | 0 | 144   |               |    |
| Heavy Trucks                    | 0                         | 0    | 0     |   | 0                         | 0    | 4     |   | 0                          | 0    | 4     |   | 0                          | 0    | 4     |   | 12    |               |    |
| Buses                           |                           |      |       |   |                           |      | 8     |   |                            |      | 4     |   |                            |      | 0     |   | 12    |               |    |
| Pedestrians                     |                           | 0    |       |   |                           | 4    |       |   |                            | 4    |       |   |                            | 0    |       |   | 4     |               |    |
| Bicycles                        | 0                         | 0    | 0     |   | 0                         | 4    | 0     |   | 0                          | 0    | 0     |   | 0                          | 0    | 0     |   | 4     |               |    |
| Scoters                         |                           |      |       |   |                           |      |       |   |                            |      |       |   |                            |      |       |   |       |               |    |
| <i>Comments:</i>                |                           |      |       |   |                           |      |       |   |                            |      |       |   |                            |      |       |   |       |               |    |

LOCATION: La Salle Ln -- Cousteau Ln  
 CITY/STATE: Ladera Ranch, CA

QC JOB #: 16966460  
 DATE: Wed, Apr 16 2025

Peak-Hour: 3:05 PM -- 4:05 PM  
 Peak 15-Min: 3:25 PM -- 3:40 PM

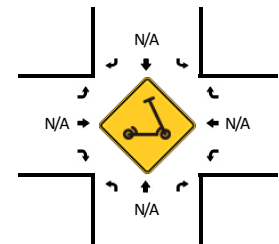
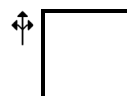
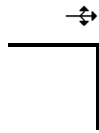
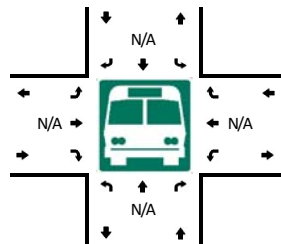
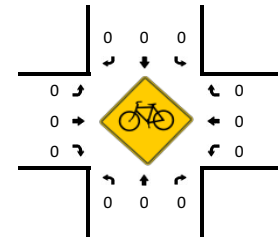
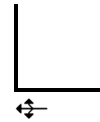
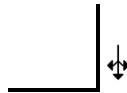
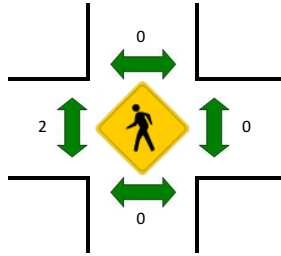
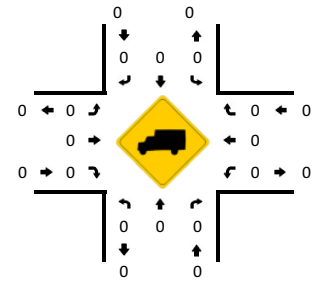
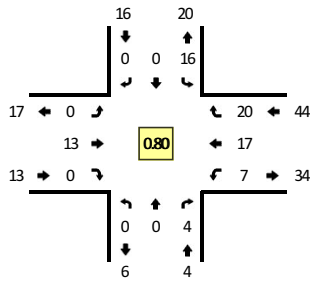

| 5-Min Count Period Beginning At | La Salle Ln (Northbound) |      |       |   | La Salle Ln (Southbound) |      |       |   | Cousteau Ln (Eastbound) |      |       |   | Cousteau Ln (Westbound) |      |       |   | Total | Hourly Totals |
|---------------------------------|--------------------------|------|-------|---|--------------------------|------|-------|---|-------------------------|------|-------|---|-------------------------|------|-------|---|-------|---------------|
|                                 | Left                     | Thru | Right | U | Left                     | Thru | Right | U | Left                    | Thru | Right | U | Left                    | Thru | Right | U |       |               |
| 6:00 AM                         | 0                        | 0    | 0     | 0 | 0                        | 0    | 0     | 0 | 0                       | 0    | 1     | 0 | 0                       | 0    | 0     | 0 | 1     |               |
| 6:05 AM                         | 0                        | 0    | 0     | 0 | 0                        | 0    | 0     | 0 | 0                       | 0    | 0     | 0 | 0                       | 0    | 0     | 0 | 0     |               |
| 6:10 AM                         | 0                        | 0    | 0     | 0 | 0                        | 0    | 0     | 0 | 0                       | 0    | 0     | 0 | 0                       | 0    | 0     | 0 | 1     |               |
| 6:15 AM                         | 0                        | 0    | 0     | 0 | 0                        | 0    | 0     | 0 | 0                       | 0    | 0     | 0 | 0                       | 0    | 0     | 0 | 1     |               |
| 6:20 AM                         | 0                        | 0    | 0     | 0 | 0                        | 0    | 0     | 0 | 0                       | 0    | 0     | 1 | 0                       | 0    | 0     | 0 | 2     |               |
| 6:25 AM                         | 0                        | 0    | 1     | 0 | 1                        | 0    | 0     | 0 | 0                       | 0    | 0     | 0 | 0                       | 1    | 0     | 0 | 3     |               |
| 6:30 AM                         | 0                        | 0    | 1     | 0 | 1                        | 0    | 0     | 0 | 0                       | 0    | 0     | 0 | 0                       | 1    | 0     | 0 | 3     |               |
| 6:35 AM                         | 0                        | 0    | 0     | 0 | 0                        | 0    | 0     | 0 | 0                       | 0    | 0     | 0 | 0                       | 0    | 0     | 0 | 0     |               |
| 6:40 AM                         | 0                        | 0    | 0     | 0 | 1                        | 0    | 0     | 0 | 0                       | 0    | 2     | 0 | 0                       | 0    | 0     | 0 | 3     |               |
| 6:45 AM                         | 0                        | 0    | 0     | 0 | 0                        | 0    | 0     | 0 | 0                       | 0    | 0     | 0 | 0                       | 0    | 1     | 0 | 1     |               |
| 6:50 AM                         | 0                        | 0    | 0     | 0 | 1                        | 0    | 0     | 0 | 0                       | 0    | 2     | 0 | 0                       | 0    | 0     | 0 | 3     |               |
| 6:55 AM                         | 0                        | 0    | 1     | 0 | 0                        | 0    | 0     | 0 | 0                       | 0    | 1     | 0 | 0                       | 0    | 0     | 0 | 2     | 20            |
| 7:00 AM                         | 0                        | 0    | 1     | 0 | 0                        | 0    | 0     | 0 | 0                       | 0    | 1     | 0 | 0                       | 0    | 0     | 0 | 3     | 22            |
| 7:05 AM                         | 0                        | 0    | 1     | 0 | 0                        | 0    | 0     | 0 | 0                       | 0    | 0     | 0 | 0                       | 0    | 0     | 0 | 1     | 23            |
| 7:10 AM                         | 0                        | 0    | 0     | 0 | 1                        | 0    | 0     | 0 | 0                       | 0    | 1     | 0 | 0                       | 0    | 0     | 0 | 3     | 25            |
| 7:15 AM                         | 0                        | 0    | 0     | 0 | 0                        | 0    | 0     | 0 | 0                       | 0    | 0     | 0 | 0                       | 0    | 0     | 0 | 0     | 24            |
| 7:20 AM                         | 0                        | 0    | 0     | 0 | 2                        | 0    | 0     | 0 | 0                       | 0    | 0     | 0 | 0                       | 0    | 1     | 0 | 3     | 25            |
| 7:25 AM                         | 0                        | 0    | 0     | 0 | 1                        | 0    | 0     | 0 | 0                       | 0    | 1     | 0 | 0                       | 0    | 0     | 0 | 3     | 25            |
| 7:30 AM                         | 0                        | 0    | 2     | 0 | 0                        | 0    | 0     | 0 | 0                       | 0    | 3     | 0 | 0                       | 0    | 1     | 0 | 6     | 28            |
| 7:35 AM                         | 0                        | 0    | 2     | 0 | 0                        | 0    | 0     | 0 | 0                       | 0    | 2     | 0 | 0                       | 0    | 0     | 0 | 4     | 32            |
| 7:40 AM                         | 0                        | 0    | 0     | 0 | 2                        | 0    | 0     | 0 | 0                       | 0    | 2     | 0 | 0                       | 0    | 0     | 0 | 4     | 33            |
| 7:45 AM                         | 0                        | 0    | 0     | 0 | 2                        | 0    | 0     | 0 | 0                       | 0    | 4     | 0 | 0                       | 0    | 2     | 0 | 8     | 40            |
| 7:50 AM                         | 0                        | 0    | 2     | 0 | 1                        | 0    | 0     | 0 | 0                       | 0    | 3     | 0 | 0                       | 0    | 0     | 1 | 7     | 44            |
| 7:55 AM                         | 0                        | 0    | 4     | 0 | 2                        | 0    | 0     | 0 | 0                       | 0    | 3     | 0 | 0                       | 0    | 3     | 0 | 12    | 54            |
| 8:00 AM                         | 0                        | 0    | 0     | 0 | 0                        | 0    | 0     | 0 | 0                       | 0    | 0     | 0 | 0                       | 2    | 0     | 1 | 3     | 54            |
| 8:05 AM                         | 0                        | 0    | 1     | 0 | 3                        | 0    | 0     | 0 | 0                       | 0    | 0     | 0 | 0                       | 2    | 1     | 0 | 7     | 60            |
| 8:10 AM                         | 0                        | 0    | 0     | 0 | 3                        | 0    | 0     | 0 | 0                       | 0    | 0     | 0 | 0                       | 0    | 0     | 0 | 3     | 60            |
| 8:15 AM                         | 0                        | 0    | 1     | 0 | 0                        | 0    | 0     | 0 | 0                       | 0    | 1     | 0 | 0                       | 0    | 0     | 1 | 3     | 63            |
| 8:20 AM                         | 0                        | 0    | 1     | 0 | 2                        | 0    | 0     | 0 | 0                       | 0    | 1     | 0 | 0                       | 0    | 0     | 1 | 5     | 65            |
| 8:25 AM                         | 0                        | 0    | 1     | 0 | 0                        | 0    | 0     | 0 | 0                       | 0    | 3     | 0 | 0                       | 1    | 0     | 0 | 5     | 67            |
| 8:30 AM                         | 0                        | 0    | 1     | 0 | 0                        | 1    | 0     | 0 | 0                       | 0    | 1     | 0 | 0                       | 0    | 0     | 0 | 3     | 64            |
| 8:35 AM                         | 0                        | 0    | 3     | 0 | 1                        | 0    | 0     | 0 | 0                       | 0    | 1     | 0 | 0                       | 1    | 0     | 1 | 7     | 67            |
| 8:40 AM                         | 0                        | 0    | 1     | 0 | 0                        | 0    | 0     | 0 | 0                       | 0    | 0     | 0 | 0                       | 0    | 2     | 0 | 3     | 66            |
| 8:45 AM                         | 0                        | 0    | 0     | 0 | 1                        | 0    | 0     | 0 | 0                       | 0    | 2     | 0 | 0                       | 1    | 0     | 0 | 4     | 62            |
| 8:50 AM                         | 0                        | 0    | 0     | 0 | 0                        | 0    | 0     | 0 | 0                       | 0    | 1     | 0 | 0                       | 1    | 3     | 1 | 6     | 61            |
| 8:55 AM                         | 0                        | 0    | 1     | 0 | 0                        | 0    | 0     | 0 | 0                       | 0    | 0     | 0 | 0                       | 0    | 0     | 0 | 1     | 50            |
| 9:00 AM                         | 0                        | 0    | 0     | 0 | 1                        | 0    | 0     | 0 | 0                       | 0    | 0     | 0 | 0                       | 2    | 2     | 0 | 5     | 52            |
| 9:05 AM                         | 0                        | 0    | 1     | 0 | 1                        | 0    | 0     | 0 | 0                       | 0    | 0     | 0 | 0                       | 0    | 1     | 1 | 4     | 49            |

Attachment B

| 5-Min Count Period Beginning At | La Salle Ln (Northbound) |      |       |   | La Salle Ln (Southbound) |      |       |   | Cousteau Ln (Eastbound) |      |       |   | Cousteau Ln (Westbound) |      |       |   | Total | Hourly Totals |
|---------------------------------|--------------------------|------|-------|---|--------------------------|------|-------|---|-------------------------|------|-------|---|-------------------------|------|-------|---|-------|---------------|
|                                 | Left                     | Thru | Right | U | Left                     | Thru | Right | U | Left                    | Thru | Right | U | Left                    | Thru | Right | U |       |               |
| 9:10 AM                         | 0                        | 0    | 0     | 0 | 2                        | 0    | 0     | 0 | 0                       | 2    | 0     | 0 | 0                       | 0    | 0     | 0 | 4     | 50            |
| 9:15 AM                         | 0                        | 0    | 0     | 0 | 0                        | 0    | 0     | 0 | 0                       | 0    | 0     | 0 | 0                       | 0    | 1     | 0 | 1     | 48            |
| 9:20 AM                         | 0                        | 0    | 0     | 0 | 0                        | 0    | 0     | 0 | 0                       | 0    | 1     | 0 | 0                       | 0    | 1     | 0 | 2     | 45            |
| 9:25 AM                         | 0                        | 0    | 0     | 0 | 1                        | 0    | 0     | 0 | 0                       | 0    | 0     | 0 | 0                       | 0    | 1     | 0 | 2     | 42            |
| 9:30 AM                         | 0                        | 0    | 0     | 0 | 1                        | 0    | 0     | 0 | 0                       | 0    | 0     | 0 | 0                       | 0    | 0     | 0 | 1     | 40            |
| 9:35 AM                         | 0                        | 0    | 1     | 0 | 0                        | 0    | 0     | 0 | 0                       | 0    | 0     | 0 | 0                       | 1    | 1     | 0 | 3     | 36            |
| 9:40 AM                         | 0                        | 0    | 0     | 0 | 1                        | 0    | 0     | 0 | 0                       | 0    | 1     | 0 | 0                       | 0    | 0     | 0 | 2     | 35            |
| 9:45 AM                         | 0                        | 0    | 0     | 0 | 1                        | 0    | 0     | 0 | 0                       | 0    | 0     | 0 | 0                       | 2    | 0     | 0 | 3     | 34            |
| 9:50 AM                         | 0                        | 0    | 0     | 0 | 0                        | 0    | 0     | 0 | 0                       | 0    | 1     | 0 | 0                       | 0    | 0     | 0 | 1     | 29            |
| 9:55 AM                         | 0                        | 0    | 0     | 0 | 1                        | 0    | 0     | 0 | 0                       | 0    | 1     | 0 | 0                       | 0    | 2     | 0 | 4     | 32            |
| 10:00 AM                        | 0                        | 0    | 0     | 0 | 0                        | 0    | 0     | 0 | 0                       | 3    | 0     | 0 | 0                       | 1    | 0     | 0 | 4     | 31            |
| 10:05 AM                        | 0                        | 0    | 0     | 0 | 0                        | 0    | 0     | 0 | 0                       | 2    | 0     | 0 | 0                       | 0    | 0     | 0 | 2     | 29            |
| 10:10 AM                        | 0                        | 0    | 0     | 0 | 0                        | 0    | 0     | 0 | 0                       | 1    | 0     | 0 | 0                       | 0    | 1     | 0 | 2     | 27            |
| 10:15 AM                        | 0                        | 0    | 1     | 0 | 0                        | 0    | 0     | 0 | 0                       | 0    | 0     | 0 | 1                       | 0    | 2     | 0 | 4     | 30            |
| 10:20 AM                        | 0                        | 0    | 1     | 0 | 0                        | 0    | 1     | 0 | 0                       | 0    | 0     | 0 | 0                       | 0    | 4     | 0 | 6     | 34            |
| 10:25 AM                        | 0                        | 0    | 0     | 0 | 1                        | 0    | 1     | 0 | 0                       | 0    | 1     | 0 | 0                       | 1    | 0     | 0 | 4     | 36            |
| 10:30 AM                        | 0                        | 0    | 2     | 0 | 1                        | 0    | 0     | 0 | 0                       | 0    | 1     | 0 | 0                       | 0    | 1     | 0 | 5     | 40            |
| 10:35 AM                        | 0                        | 0    | 1     | 0 | 0                        | 0    | 0     | 0 | 0                       | 0    | 0     | 0 | 0                       | 0    | 1     | 0 | 2     | 39            |
| 10:40 AM                        | 0                        | 0    | 0     | 0 | 0                        | 0    | 0     | 0 | 0                       | 1    | 0     | 0 | 0                       | 0    | 0     | 0 | 1     | 38            |
| 10:45 AM                        | 0                        | 0    | 0     | 0 | 2                        | 0    | 0     | 0 | 0                       | 0    | 0     | 0 | 0                       | 0    | 1     | 0 | 3     | 38            |
| 10:50 AM                        | 0                        | 0    | 0     | 0 | 2                        | 0    | 0     | 0 | 0                       | 0    | 0     | 0 | 0                       | 0    | 2     | 0 | 4     | 41            |
| 10:55 AM                        | 0                        | 0    | 1     | 0 | 2                        | 0    | 0     | 0 | 0                       | 0    | 0     | 0 | 0                       | 0    | 0     | 0 | 3     | 40            |
| 11:00 AM                        | 0                        | 0    | 0     | 0 | 0                        | 0    | 0     | 0 | 0                       | 0    | 1     | 0 | 0                       | 0    | 0     | 0 | 1     | 37            |
| 11:05 AM                        | 0                        | 0    | 1     | 0 | 0                        | 0    | 0     | 0 | 0                       | 0    | 0     | 0 | 1                       | 1    | 0     | 0 | 3     | 38            |
| 11:10 AM                        | 0                        | 0    | 0     | 0 | 0                        | 0    | 0     | 0 | 0                       | 0    | 0     | 0 | 1                       | 0    | 1     | 0 | 2     | 38            |
| 11:15 AM                        | 0                        | 0    | 0     | 0 | 0                        | 0    | 0     | 0 | 0                       | 0    | 0     | 0 | 0                       | 0    | 1     | 0 | 1     | 35            |
| 11:20 AM                        | 0                        | 0    | 0     | 0 | 1                        | 0    | 0     | 0 | 0                       | 0    | 0     | 0 | 1                       | 0    | 0     | 0 | 2     | 31            |
| 11:25 AM                        | 0                        | 0    | 0     | 0 | 1                        | 0    | 0     | 0 | 0                       | 0    | 0     | 0 | 0                       | 0    | 1     | 0 | 2     | 29            |
| 11:30 AM                        | 0                        | 0    | 0     | 0 | 0                        | 0    | 0     | 0 | 0                       | 0    | 0     | 0 | 3                       | 0    | 1     | 0 | 4     | 28            |
| 11:35 AM                        | 0                        | 0    | 0     | 0 | 0                        | 0    | 0     | 0 | 0                       | 0    | 0     | 0 | 1                       | 0    | 1     | 0 | 2     | 28            |
| 11:40 AM                        | 0                        | 1    | 0     | 0 | 2                        | 0    | 0     | 0 | 0                       | 0    | 1     | 0 | 0                       | 0    | 0     | 0 | 4     | 31            |
| 11:45 AM                        | 0                        | 0    | 0     | 0 | 0                        | 0    | 0     | 0 | 0                       | 0    | 1     | 0 | 0                       | 2    | 1     | 0 | 4     | 32            |
| 11:50 AM                        | 0                        | 0    | 0     | 0 | 1                        | 0    | 0     | 0 | 0                       | 0    | 0     | 0 | 0                       | 1    | 1     | 1 | 4     | 32            |
| 11:55 AM                        | 0                        | 0    | 1     | 0 | 1                        | 1    | 2     | 0 | 0                       | 2    | 0     | 0 | 1                       | 0    | 3     | 0 | 11    | 40            |
| 12:00 PM                        | 0                        | 0    | 1     | 0 | 3                        | 0    | 0     | 0 | 0                       | 2    | 0     | 0 | 0                       | 0    | 0     | 0 | 6     | 45            |
| 12:05 PM                        | 0                        | 0    | 0     | 0 | 0                        | 1    | 0     | 0 | 0                       | 1    | 0     | 0 | 0                       | 2    | 0     | 0 | 4     | 46            |
| 12:10 PM                        | 0                        | 0    | 0     | 0 | 1                        | 0    | 0     | 0 | 0                       | 2    | 0     | 0 | 0                       | 1    | 1     | 0 | 5     | 49            |
| 12:15 PM                        | 0                        | 0    | 0     | 0 | 1                        | 0    | 0     | 0 | 0                       | 0    | 0     | 0 | 2                       | 0    | 1     | 0 | 4     | 52            |
| 12:20 PM                        | 0                        | 0    | 2     | 0 | 0                        | 0    | 0     | 0 | 0                       | 1    | 0     | 0 | 0                       | 0    | 0     | 0 | 3     | 53            |
| 12:25 PM                        | 0                        | 0    | 1     | 0 | 1                        | 0    | 0     | 0 | 0                       | 0    | 0     | 0 | 0                       | 0    | 1     | 0 | 3     | 54            |
| 12:30 PM                        | 0                        | 0    | 1     | 0 | 1                        | 0    | 0     | 0 | 0                       | 0    | 0     | 0 | 0                       | 1    | 0     | 0 | 3     | 53            |
| 12:35 PM                        | 0                        | 0    | 1     | 0 | 1                        | 0    | 0     | 0 | 0                       | 0    | 0     | 0 | 1                       | 0    | 0     | 0 | 3     | 54            |
| 12:40 PM                        | 0                        | 0    | 0     | 0 | 1                        | 0    | 0     | 0 | 0                       | 1    | 0     | 0 | 1                       | 0    | 2     | 0 | 5     | 55            |
| 12:45 PM                        | 0                        | 0    | 1     | 0 | 0                        | 0    | 0     | 0 | 0                       | 0    | 0     | 0 | 0                       | 0    | 0     | 0 | 1     | 52            |
| 12:50 PM                        | 0                        | 0    | 1     | 0 | 1                        | 0    | 1     | 0 | 1                       | 0    | 0     | 0 | 2                       | 1    | 1     | 0 | 8     | 56            |
| 12:55 PM                        | 0                        | 0    | 1     | 0 | 1                        | 1    | 0     | 0 | 0                       | 0    | 0     | 0 | 0                       | 0    | 0     | 0 | 3     | 48            |
| 1:00 PM                         | 0                        | 0    | 0     | 0 | 1                        | 0    | 0     | 0 | 0                       | 1    | 1     | 0 | 1                       | 1    | 1     | 0 | 6     | 48            |
| 1:05 PM                         | 0                        | 1    | 1     | 0 | 0                        | 0    | 1     | 0 | 0                       | 0    | 0     | 0 | 0                       | 1    | 1     | 0 | 5     | 49            |
| 1:10 PM                         | 0                        | 0    | 1     | 0 | 0                        | 0    | 0     | 0 | 0                       | 0    | 0     | 0 | 0                       | 2    | 0     | 0 | 3     | 47            |
| 1:15 PM                         | 0                        | 0    | 0     | 0 | 0                        | 0    | 0     | 0 | 0                       | 1    | 0     | 0 | 0                       | 2    | 1     | 0 | 4     | 47            |
| 1:20 PM                         | 0                        | 0    | 0     | 0 | 0                        | 0    | 0     | 0 | 0                       | 1    | 0     | 0 | 0                       | 0    | 1     | 0 | 2     | 46            |
| 1:25 PM                         | 0                        | 0    | 0     | 0 | 1                        | 0    | 0     | 0 | 0                       | 0    | 0     | 0 | 1                       | 1    | 1     | 0 | 4     | 47            |
| 1:30 PM                         | 0                        | 0    | 0     | 0 | 1                        | 0    | 0     | 0 | 0                       | 0    | 0     | 0 | 0                       | 2    | 0     | 0 | 3     | 47            |
| 1:35 PM                         | 0                        | 0    | 0     | 0 | 0                        | 0    | 0     | 0 | 0                       | 0    | 0     | 0 | 0                       | 0    | 1     | 0 | 1     | 45            |
| 1:40 PM                         | 0                        | 0    | 0     | 0 | 1                        | 0    | 0     | 0 | 0                       | 0    | 0     | 0 | 2                       | 0    | 0     | 0 | 3     | 43            |
| 1:45 PM                         | 0                        | 0    | 2     | 0 | 0                        | 0    | 0     | 0 | 0                       | 0    | 0     | 0 | 1                       | 0    | 0     | 0 | 3     | 45            |
| 1:50 PM                         | 0                        | 0    | 1     | 0 | 1                        | 0    | 0     | 0 | 0                       | 1    | 0     | 0 | 1                       | 1    | 0     | 0 | 5     | 42            |
| 1:55 PM                         | 0                        | 0    | 0     | 0 | 0                        | 0    | 0     | 0 | 0                       | 0    | 0     | 0 | 0                       | 1    | 0     | 0 | 1     | 40            |
| 2:00 PM                         | 0                        | 0    | 0     | 0 | 0                        | 0    | 0     | 0 | 0                       | 1    | 0     | 0 | 0                       | 0    | 0     | 0 | 1     | 35            |
| 2:05 PM                         | 0                        | 0    | 0     | 0 | 0                        | 0    | 0     | 0 | 0                       | 2    | 0     | 0 | 0                       | 0    | 1     | 0 | 3     | 33            |
| 2:10 PM                         | 0                        | 0    | 0     | 0 | 0                        | 0    | 0     | 0 | 0                       | 0    | 0     | 0 | 0                       | 0    | 0     | 0 | 0     | 30            |
| 2:15 PM                         | 0                        | 0    | 0     | 0 | 0                        | 0    | 0     | 0 | 0                       | 0    | 0     | 0 | 1                       | 0    | 1     | 0 | 2     | 28            |
| 2:20 PM                         | 0                        | 0    | 1     | 0 | 1                        | 0    | 0     | 0 | 0                       | 2    | 0     | 0 | 2                       | 0    | 0     | 0 | 6     | 32            |
| 2:25 PM                         | 0                        | 0    | 1     | 0 | 0                        | 0    | 0     | 0 | 0                       | 0    | 0     | 0 | 1                       | 0    | 0     | 0 | 2     | 30            |
| 2:30 PM                         | 0                        | 0    | 2     | 0 | 1                        | 0    | 0     | 0 | 0                       | 1    | 0     | 0 | 1                       | 0    | 0     | 0 | 5     | 32            |
| 2:35 PM                         | 0                        | 0    | 0     | 0 | 0                        | 0    | 0     | 0 | 0                       | 0    | 0     | 0 | 0                       | 3    | 0     | 0 | 3     | 34            |
| 2:40 PM                         | 0                        | 0    | 0     | 0 | 0                        | 0    | 0     | 0 | 0                       | 2    | 0     | 0 | 1                       | 4    | 0     | 0 | 7     | 38            |
| 2:45 PM                         | 0                        | 0    | 0     | 0 | 0                        | 0    | 0     | 0 | 0                       | 2    | 0     | 0 | 0                       | 0    | 1     | 0 | 3     | 38            |
| 2:50 PM                         | 0                        | 0    | 1     | 0 | 0                        | 0    | 0     | 0 | 0                       | 2    | 0     | 0 | 0                       | 0    | 0     | 0 | 3     | 36            |
| 2:55 PM                         | 0                        | 0    | 0     | 0 | 0                        | 0    | 0     | 0 | 0                       | 2    | 0     | 0 | 1                       | 2    | 0     | 0 | 5     | 40            |
| 3:00 PM                         | 0                        | 0    | 0     | 0 | 0                        | 0    | 0     | 0 | 0                       | 1    | 0     | 0 | 2                       | 1    | 0     | 0 | 4     | 43            |
| 3:05 PM                         | 0                        | 0    | 0     | 0 | 1                        | 0    | 0     | 0 | 0                       | 1    | 0     | 0 | 0                       | 3    | 2     | 0 | 7     | 47            |
| 3:10 PM                         | 0                        | 0    | 0     | 0 | 1                        | 0    | 0     | 0 | 0                       | 0    | 0     | 0 | 0                       | 2    | 0     | 0 | 3     | 50            |
| 3:15 PM                         | 0                        | 0    | 0     | 0 | 2                        | 0    | 0     | 0 | 0                       | 0    | 0     | 0 | 0                       | 3    | 2     | 0 | 7     | 55            |
| 3:20 PM                         | 0                        | 0    | 0     | 0 | 1                        | 0    | 0     | 0 | 0                       | 1    | 0     | 0 | 0                       | 1    | 1     | 0 | 4     | 53            |
| 3:25 PM                         | 0                        | 0    | 0     | 0 | 0                        | 0    | 0     | 0 | 0                       | 2    | 0     | 0 | 0                       | 1    | 1     | 0 | 4     | 55            |
| 3:30 PM                         | 0                        | 0    | 2     | 0 | 2                        | 0    | 0     | 0 | 0                       | 5    | 0     | 0 | 1                       | 0    | 5     | 0 | 15    | 65            |
| 3:35 PM                         | 0                        | 0    | 0     | 0 | 2                        | 0    | 0     | 0 | 0                       | 1    | 0     | 0 | 1                       | 1    | 0     | 0 | 5     | 67            |
| 3:40 PM                         | 0                        | 0    | 0     | 0 | 0                        | 0    | 0     | 0 | 0                       | 0    | 0     | 0 | 2                       | 0    | 0     | 0 | 2     | 62            |
| 3:45 PM                         | 0                        | 0    | 0     | 0 | 3                        | 0    | 0     | 0 | 0                       | 1    | 0     | 0 | 0                       | 2    | 2     | 1 | 9     | 68            |
| 3:50 PM                         | 0                        | 0    | 2     | 0 | 0                        | 0    | 0     | 0 | 0                       | 0    | 0     | 0 | 0                       | 1    | 3     | 0 | 6     | 71            |
| 3:55 PM                         | 0                        | 0    | 0     | 0 | 1                        | 0    | 0     | 0 | 0                       | 2    | 0     | 0 | 0                       | 1    | 0     | 0 | 4     | 70            |
| 4:00 PM                         | 0                        | 0    | 0     | 0 | 3                        | 0    | 0     | 0 | 0                       | 0    | 0     | 0 | 2                       | 2    | 4     | 0 | 11    | 77            |
| 4:05 PM                         | 0                        | 0    | 0     | 0 | 2                        | 0    | 0     | 0 | 0                       | 0    | 0     | 0 | 2                       | 1    | 1     | 0 | 6     | 76            |
| 4:10 PM                         | 0                        | 0    | 0     | 0 | 2                        | 0    | 0     | 0 | 0                       | 2    | 0     | 0 | 0                       | 0    | 0     | 0 | 4     | 77            |
| 4:15 PM                         | 0                        | 0    | 0     | 0 | 0                        | 0    | 0     | 0 | 0                       | 0    | 0     | 0 | 0                       | 1    | 1     | 0 | 2     | 72            |
| 4:20 PM                         | 0                        | 0    | 0     | 0 | 1                        | 0    | 0     | 0 | 0                       | 2    | 0     | 0 | 0                       | 0    | 1     | 0 | 4     | 72            |
| 4:25 PM                         | 0                        | 0    | 3     | 0 | 0                        | 1    | 0     | 0 | 0                       | 1    | 0     | 0 | 0                       | 0    | 0     | 0 | 5     | 73            |

**Attachment B**

| 5-Min Count Period Beginning At | La Salle Ln (Northbound) |      |       |   | La Salle Ln (Southbound) |      |       |   | Cousteau Ln (Eastbound) |      |       |   | Cousteau Ln (Westbound) |      |       |   | Total | Hourly Totals |
|---------------------------------|--------------------------|------|-------|---|--------------------------|------|-------|---|-------------------------|------|-------|---|-------------------------|------|-------|---|-------|---------------|
|                                 | Left                     | Thru | Right | U | Left                     | Thru | Right | U | Left                    | Thru | Right | U | Left                    | Thru | Right | U |       |               |
| 4:30 PM                         | 0                        | 0    | 1     | 0 | 1                        | 0    | 0     | 0 | 0                       | 2    | 0     | 0 | 2                       | 1    | 1     | 0 | 8     | 66            |
| 4:35 PM                         | 0                        | 0    | 0     | 0 | 1                        | 0    | 0     | 0 | 0                       | 0    | 1     | 0 | 2                       | 1    | 2     | 0 | 7     | 68            |
| 4:40 PM                         | 0                        | 0    | 0     | 0 | 1                        | 0    | 0     | 0 | 0                       | 0    | 0     | 0 | 2                       | 0    | 0     | 0 | 3     | 69            |
| 4:45 PM                         | 0                        | 0    | 0     | 0 | 0                        | 0    | 0     | 0 | 0                       | 0    | 0     | 0 | 1                       | 0    | 0     | 0 | 1     | 61            |
| 4:50 PM                         | 0                        | 0    | 2     | 0 | 0                        | 0    | 0     | 0 | 0                       | 0    | 2     | 0 | 1                       | 1    | 1     | 0 | 7     | 62            |
| 4:55 PM                         | 0                        | 0    | 0     | 0 | 1                        | 0    | 0     | 0 | 0                       | 0    | 2     | 0 | 0                       | 3    | 0     | 0 | 6     | 64            |
| 5:00 PM                         | 0                        | 0    | 1     | 0 | 0                        | 0    | 0     | 0 | 0                       | 0    | 0     | 0 | 1                       | 1    | 1     | 0 | 4     | 57            |
| 5:05 PM                         | 0                        | 0    | 1     | 0 | 1                        | 0    | 0     | 0 | 0                       | 0    | 0     | 0 | 0                       | 4    | 1     | 0 | 7     | 58            |
| 5:10 PM                         | 0                        | 0    | 0     | 0 | 0                        | 0    | 0     | 0 | 0                       | 0    | 0     | 0 | 1                       | 0    | 0     | 0 | 1     | 55            |
| 5:15 PM                         | 0                        | 0    | 0     | 0 | 1                        | 0    | 0     | 0 | 0                       | 0    | 1     | 0 | 0                       | 4    | 1     | 0 | 7     | 60            |
| 5:20 PM                         | 0                        | 0    | 3     | 0 | 0                        | 0    | 0     | 0 | 0                       | 0    | 0     | 0 | 0                       | 0    | 0     | 0 | 3     | 59            |
| 5:25 PM                         | 0                        | 0    | 2     | 0 | 1                        | 0    | 0     | 0 | 0                       | 0    | 1     | 0 | 0                       | 1    | 3     | 0 | 8     | 62            |
| 5:30 PM                         | 0                        | 0    | 1     | 0 | 0                        | 0    | 0     | 0 | 0                       | 0    | 2     | 0 | 1                       | 3    | 4     | 0 | 11    | 65            |
| 5:35 PM                         | 0                        | 0    | 0     | 0 | 1                        | 0    | 0     | 0 | 0                       | 0    | 2     | 0 | 2                       | 3    | 0     | 0 | 8     | 66            |
| 5:40 PM                         | 0                        | 0    | 1     | 0 | 0                        | 0    | 0     | 0 | 0                       | 0    | 0     | 0 | 1                       | 0    | 2     | 0 | 4     | 67            |
| 5:45 PM                         | 0                        | 0    | 1     | 0 | 1                        | 0    | 0     | 0 | 0                       | 0    | 0     | 0 | 0                       | 1    | 1     | 0 | 4     | 70            |
| 5:50 PM                         | 0                        | 0    | 0     | 0 | 0                        | 0    | 0     | 0 | 0                       | 0    | 0     | 0 | 1                       | 0    | 0     | 0 | 1     | 64            |
| 5:55 PM                         | 0                        | 0    | 1     | 0 | 0                        | 0    | 0     | 0 | 0                       | 0    | 0     | 0 | 1                       | 1    | 1     | 0 | 4     | 62            |
| 6:00 PM                         | 0                        | 0    | 2     | 0 | 0                        | 0    | 0     | 0 | 0                       | 0    | 0     | 0 | 0                       | 0    | 0     | 0 | 2     | 60            |
| 6:05 PM                         | 0                        | 0    | 0     | 0 | 1                        | 0    | 0     | 0 | 0                       | 0    | 1     | 0 | 2                       | 2    | 2     | 0 | 8     | 61            |
| 6:10 PM                         | 0                        | 0    | 1     | 0 | 0                        | 0    | 0     | 0 | 0                       | 0    | 1     | 0 | 3                       | 0    | 0     | 0 | 5     | 65            |
| 6:15 PM                         | 0                        | 0    | 1     | 0 | 1                        | 0    | 0     | 0 | 0                       | 0    | 0     | 0 | 0                       | 1    | 1     | 0 | 4     | 62            |
| 6:20 PM                         | 0                        | 0    | 1     | 0 | 0                        | 0    | 0     | 0 | 0                       | 0    | 0     | 0 | 0                       | 0    | 1     | 0 | 2     | 61            |
| 6:25 PM                         | 0                        | 0    | 0     | 0 | 0                        | 0    | 0     | 0 | 0                       | 0    | 0     | 0 | 0                       | 2    | 1     | 0 | 3     | 56            |
| 6:30 PM                         | 0                        | 0    | 0     | 0 | 0                        | 0    | 0     | 0 | 0                       | 0    | 0     | 0 | 0                       | 1    | 1     | 0 | 2     | 47            |
| 6:35 PM                         | 0                        | 0    | 1     | 0 | 0                        | 0    | 0     | 0 | 0                       | 0    | 0     | 0 | 1                       | 0    | 0     | 0 | 2     | 41            |
| 6:40 PM                         | 0                        | 0    | 0     | 0 | 2                        | 0    | 0     | 0 | 0                       | 0    | 0     | 0 | 1                       | 1    | 1     | 0 | 5     | 42            |
| 6:45 PM                         | 0                        | 0    | 1     | 0 | 0                        | 0    | 0     | 0 | 0                       | 0    | 1     | 0 | 1                       | 1    | 0     | 0 | 4     | 42            |
| 6:50 PM                         | 0                        | 0    | 2     | 0 | 1                        | 0    | 0     | 0 | 0                       | 0    | 1     | 0 | 1                       | 0    | 0     | 0 | 5     | 46            |
| 6:55 PM                         | 0                        | 0    | 4     | 0 | 1                        | 0    | 0     | 0 | 0                       | 0    | 0     | 0 | 0                       | 1    | 0     | 0 | 6     | 48            |
| 7:00 PM                         | 0                        | 0    | 1     | 0 | 1                        | 0    | 0     | 0 | 0                       | 0    | 0     | 0 | 2                       | 0    | 0     | 0 | 4     | 50            |
| 7:05 PM                         | 0                        | 0    | 0     | 0 | 0                        | 0    | 0     | 0 | 0                       | 0    | 0     | 0 | 2                       | 0    | 2     | 0 | 4     | 46            |
| 7:10 PM                         | 0                        | 0    | 1     | 0 | 3                        | 0    | 0     | 0 | 0                       | 0    | 0     | 0 | 0                       | 2    | 1     | 0 | 7     | 48            |
| 7:15 PM                         | 0                        | 0    | 0     | 0 | 0                        | 0    | 0     | 0 | 0                       | 0    | 0     | 0 | 0                       | 0    | 0     | 0 | 0     | 44            |
| 7:20 PM                         | 0                        | 0    | 0     | 0 | 0                        | 0    | 0     | 0 | 0                       | 0    | 1     | 0 | 1                       | 0    | 1     | 0 | 3     | 45            |
| 7:25 PM                         | 0                        | 0    | 0     | 0 | 0                        | 0    | 0     | 0 | 0                       | 0    | 0     | 0 | 2                       | 0    | 2     | 0 | 4     | 46            |
| 7:30 PM                         | 0                        | 0    | 1     | 0 | 0                        | 0    | 0     | 0 | 0                       | 0    | 0     | 0 | 0                       | 0    | 0     | 0 | 1     | 45            |
| 7:35 PM                         | 0                        | 0    | 1     | 0 | 0                        | 0    | 0     | 0 | 0                       | 0    | 0     | 0 | 0                       | 1    | 2     | 1 | 5     | 48            |
| 7:40 PM                         | 0                        | 0    | 1     | 0 | 0                        | 0    | 0     | 0 | 0                       | 0    | 1     | 0 | 1                       | 0    | 0     | 0 | 3     | 46            |
| 7:45 PM                         | 0                        | 0    | 0     | 0 | 1                        | 0    | 0     | 0 | 0                       | 0    | 1     | 0 | 0                       | 3    | 0     | 0 | 5     | 47            |
| 7:50 PM                         | 0                        | 0    | 0     | 0 | 0                        | 0    | 0     | 0 | 0                       | 0    | 0     | 0 | 0                       | 0    | 1     | 0 | 1     | 43            |
| 7:55 PM                         | 0                        | 0    | 0     | 0 | 0                        | 0    | 0     | 0 | 0                       | 0    | 0     | 0 | 1                       | 1    | 3     | 0 | 5     | 42            |
| 8:00 PM                         | 0                        | 0    | 0     | 0 | 1                        | 0    | 0     | 0 | 0                       | 0    | 0     | 0 | 0                       | 1    | 0     | 0 | 2     | 40            |
| 8:05 PM                         | 0                        | 0    | 0     | 0 | 1                        | 0    | 0     | 0 | 0                       | 0    | 0     | 0 | 0                       | 0    | 0     | 0 | 1     | 37            |
| 8:10 PM                         | 0                        | 0    | 0     | 0 | 0                        | 0    | 0     | 0 | 0                       | 0    | 0     | 0 | 0                       | 0    | 2     | 0 | 2     | 32            |
| 8:15 PM                         | 0                        | 0    | 0     | 0 | 0                        | 0    | 0     | 0 | 0                       | 0    | 0     | 0 | 1                       | 0    | 0     | 0 | 1     | 33            |
| 8:20 PM                         | 0                        | 0    | 0     | 0 | 1                        | 0    | 0     | 0 | 0                       | 0    | 1     | 0 | 0                       | 0    | 0     | 0 | 2     | 32            |
| 8:25 PM                         | 0                        | 0    | 0     | 0 | 0                        | 0    | 0     | 0 | 0                       | 0    | 1     | 0 | 1                       | 0    | 0     | 0 | 2     | 30            |
| 8:30 PM                         | 0                        | 0    | 0     | 0 | 0                        | 0    | 0     | 0 | 0                       | 0    | 0     | 0 | 1                       | 0    | 0     | 0 | 1     | 30            |
| 8:35 PM                         | 0                        | 0    | 0     | 0 | 0                        | 0    | 0     | 0 | 0                       | 0    | 0     | 0 | 0                       | 1    | 0     | 0 | 1     | 26            |
| 8:40 PM                         | 0                        | 0    | 0     | 0 | 0                        | 0    | 0     | 0 | 0                       | 0    | 0     | 0 | 0                       | 3    | 0     | 0 | 3     | 26            |
| 8:45 PM                         | 0                        | 0    | 0     | 0 | 0                        | 0    | 0     | 0 | 0                       | 0    | 0     | 0 | 0                       | 1    | 1     | 0 | 2     | 23            |
| 8:50 PM                         | 0                        | 0    | 0     | 0 | 0                        | 0    | 0     | 0 | 0                       | 0    | 0     | 0 | 1                       | 0    | 0     | 0 | 1     | 23            |
| 8:55 PM                         | 0                        | 0    | 0     | 0 | 0                        | 0    | 0     | 0 | 0                       | 0    | 0     | 0 | 0                       | 0    | 1     | 0 | 1     | 19            |
| 9:00 PM                         | 0                        | 0    | 1     | 0 | 0                        | 0    | 0     | 0 | 0                       | 0    | 1     | 0 | 0                       | 0    | 0     | 0 | 2     | 19            |
| 9:05 PM                         | 0                        | 0    | 0     | 0 | 0                        | 0    | 0     | 0 | 0                       | 0    | 0     | 0 | 0                       | 0    | 0     | 0 | 0     | 18            |
| 9:10 PM                         | 0                        | 0    | 0     | 0 | 0                        | 0    | 0     | 0 | 0                       | 0    | 0     | 0 | 0                       | 0    | 0     | 0 | 0     | 16            |
| 9:15 PM                         | 0                        | 0    | 0     | 0 | 0                        | 0    | 0     | 0 | 0                       | 0    | 0     | 0 | 0                       | 0    | 0     | 0 | 0     | 15            |
| 9:20 PM                         | 0                        | 0    | 0     | 0 | 1                        | 0    | 0     | 0 | 0                       | 0    | 0     | 0 | 0                       | 0    | 1     | 0 | 2     | 15            |
| 9:25 PM                         | 0                        | 0    | 0     | 0 | 0                        | 0    | 0     | 0 | 0                       | 0    | 0     | 0 | 2                       | 0    | 1     | 0 | 3     | 16            |
| 9:30 PM                         | 0                        | 0    | 0     | 0 | 0                        | 0    | 0     | 0 | 0                       | 0    | 0     | 0 | 0                       | 0    | 0     | 0 | 0     | 15            |
| 9:35 PM                         | 0                        | 0    | 0     | 0 | 0                        | 0    | 0     | 0 | 0                       | 0    | 0     | 0 | 0                       | 1    | 0     | 0 | 1     | 15            |
| 9:40 PM                         | 0                        | 0    | 0     | 0 | 0                        | 0    | 0     | 0 | 0                       | 0    | 0     | 0 | 2                       | 0    | 0     | 0 | 2     | 14            |
| 9:45 PM                         | 0                        | 0    | 0     | 0 | 0                        | 0    | 0     | 0 | 0                       | 0    | 0     | 0 | 0                       | 1    | 0     | 0 | 1     | 13            |
| 9:50 PM                         | 0                        | 0    | 0     | 0 | 1                        | 0    | 0     | 0 | 0                       | 0    | 0     | 0 | 0                       | 0    | 1     | 0 | 2     | 14            |
| 9:55 PM                         | 0                        | 0    | 0     | 0 | 0                        | 0    | 0     | 0 | 0                       | 0    | 0     | 0 | 0                       | 0    | 0     | 0 | 0     | 13            |
| Peak 15-Min Flowrates           | Northbound               |      |       |   | Southbound               |      |       |   | Eastbound               |      |       |   | Westbound               |      |       |   | Total |               |
|                                 | Left                     | Thru | Right | U | Left                     | Thru | Right | U | Left                    | Thru | Right | U | Left                    | Thru | Right | U |       |               |
| All Vehicles                    | 0                        | 0    | 8     | 0 | 16                       | 0    | 0     | 0 | 0                       | 32   | 0     | 0 | 8                       | 8    | 24    | 0 | 96    |               |
| Heavy Trucks                    | 0                        | 0    | 0     | 0 | 0                        | 0    | 0     | 0 | 0                       | 0    | 0     | 0 | 0                       | 0    | 0     | 0 | 0     |               |
| Buses                           |                          |      |       |   |                          |      |       |   |                         |      |       |   |                         |      |       |   |       |               |
| Pedestrians                     |                          | 0    |       |   |                          | 0    |       |   |                         | 0    |       |   |                         | 0    |       |   | 0     |               |
| Bicycles                        | 0                        | 0    | 0     |   | 0                        | 0    | 0     |   | 0                       | 0    | 0     |   | 0                       | 0    | 0     |   | 0     |               |
| Scoters                         |                          |      |       |   |                          |      |       |   |                         |      |       |   |                         |      |       |   |       |               |
| <i>Comments:</i>                |                          |      |       |   |                          |      |       |   |                         |      |       |   |                         |      |       |   |       |               |

Report generated on 4/25/2025 4:03 PM

SOURCE: Quality Counts, LLC (<http://www.qualitycounts.net>) 1-877-580-2212

LOCATION: Sutherland Dr -- Sterling Glen  
 CITY/STATE: Ladera Ranch, CA

QC JOB #: 16966461  
 DATE: Wed, Apr 16 2025

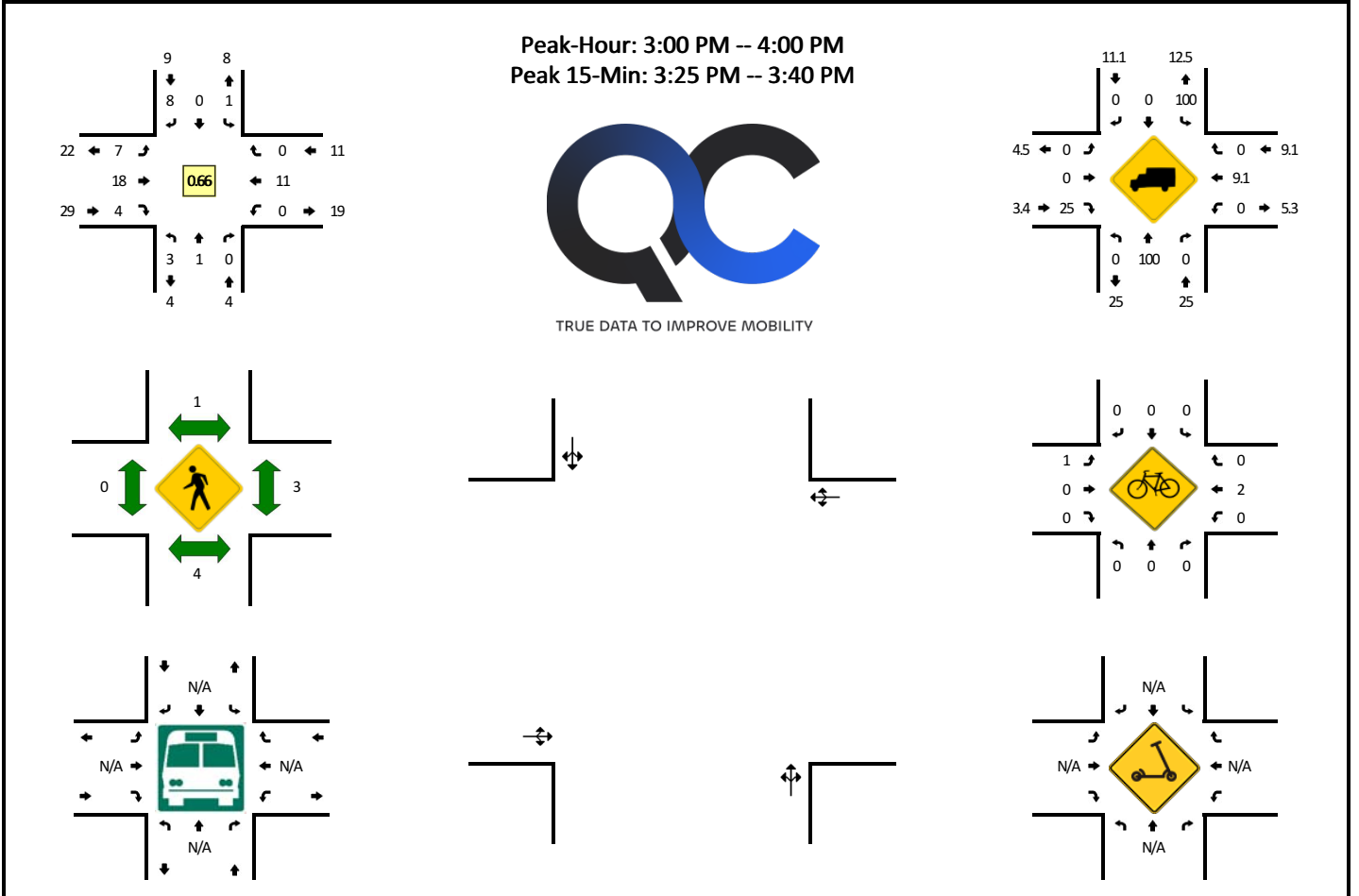

| 5-Min Count Period Beginning At | Sutherland Dr (Northbound) |      |       |   | Sutherland Dr (Southbound) |      |       |   | Sterling Glen (Eastbound) |      |       |   | Sterling Glen (Westbound) |      |       |   | Total | Hourly Totals |
|---------------------------------|----------------------------|------|-------|---|----------------------------|------|-------|---|---------------------------|------|-------|---|---------------------------|------|-------|---|-------|---------------|
|                                 | Left                       | Thru | Right | U | Left                       | Thru | Right | U | Left                      | Thru | Right | U | Left                      | Thru | Right | U |       |               |
| 6:00 AM                         | 1                          | 0    | 0     | 0 | 0                          | 0    | 0     | 0 | 0                         | 0    | 0     | 0 | 0                         | 0    | 0     | 0 | 1     |               |
| 6:05 AM                         | 0                          | 0    | 0     | 0 | 0                          | 0    | 0     | 0 | 0                         | 0    | 0     | 0 | 0                         | 0    | 0     | 0 | 0     |               |
| 6:10 AM                         | 0                          | 0    | 0     | 0 | 0                          | 0    | 0     | 0 | 0                         | 0    | 0     | 0 | 0                         | 0    | 0     | 0 | 0     |               |
| 6:15 AM                         | 0                          | 0    | 0     | 0 | 0                          | 0    | 0     | 0 | 0                         | 0    | 0     | 0 | 0                         | 0    | 0     | 0 | 0     |               |
| 6:20 AM                         | 0                          | 0    | 0     | 0 | 0                          | 0    | 0     | 1 | 0                         | 1    | 0     | 0 | 0                         | 0    | 0     | 0 | 2     |               |
| 6:25 AM                         | 0                          | 0    | 0     | 0 | 0                          | 0    | 1     | 0 | 0                         | 0    | 0     | 0 | 0                         | 0    | 0     | 0 | 1     |               |
| 6:30 AM                         | 0                          | 0    | 0     | 0 | 0                          | 0    | 0     | 0 | 0                         | 0    | 0     | 0 | 0                         | 0    | 1     | 0 | 1     |               |
| 6:35 AM                         | 0                          | 0    | 0     | 0 | 0                          | 0    | 0     | 0 | 0                         | 0    | 0     | 0 | 0                         | 0    | 0     | 0 | 0     |               |
| 6:40 AM                         | 0                          | 0    | 0     | 0 | 0                          | 0    | 0     | 0 | 0                         | 0    | 0     | 0 | 0                         | 0    | 0     | 0 | 0     |               |
| 6:45 AM                         | 0                          | 0    | 0     | 0 | 0                          | 0    | 0     | 0 | 0                         | 0    | 0     | 0 | 0                         | 1    | 0     | 0 | 1     |               |
| 6:50 AM                         | 0                          | 0    | 0     | 0 | 0                          | 0    | 0     | 0 | 0                         | 0    | 0     | 0 | 0                         | 0    | 0     | 0 | 0     |               |
| 6:55 AM                         | 0                          | 0    | 0     | 0 | 0                          | 0    | 0     | 0 | 0                         | 0    | 0     | 0 | 0                         | 0    | 0     | 0 | 0     | 6             |
| 7:00 AM                         | 0                          | 0    | 0     | 0 | 0                          | 0    | 0     | 0 | 0                         | 0    | 0     | 0 | 0                         | 0    | 0     | 0 | 0     | 5             |
| 7:05 AM                         | 0                          | 0    | 0     | 0 | 0                          | 0    | 0     | 0 | 0                         | 0    | 0     | 0 | 0                         | 2    | 0     | 0 | 2     | 7             |
| 7:10 AM                         | 1                          | 0    | 0     | 0 | 0                          | 0    | 0     | 0 | 0                         | 1    | 0     | 0 | 0                         | 1    | 0     | 0 | 3     | 10            |
| 7:15 AM                         | 0                          | 0    | 0     | 0 | 0                          | 0    | 1     | 0 | 0                         | 0    | 0     | 0 | 0                         | 1    | 0     | 0 | 2     | 12            |
| 7:20 AM                         | 0                          | 0    | 0     | 0 | 0                          | 0    | 0     | 0 | 0                         | 0    | 0     | 0 | 0                         | 1    | 0     | 0 | 1     | 11            |
| 7:25 AM                         | 0                          | 0    | 0     | 0 | 0                          | 0    | 0     | 0 | 1                         | 1    | 0     | 0 | 0                         | 1    | 0     | 0 | 3     | 13            |
| 7:30 AM                         | 0                          | 0    | 0     | 0 | 0                          | 0    | 1     | 0 | 0                         | 0    | 0     | 0 | 0                         | 1    | 0     | 0 | 2     | 14            |
| 7:35 AM                         | 0                          | 0    | 0     | 0 | 0                          | 0    | 0     | 0 | 0                         | 0    | 0     | 0 | 0                         | 1    | 0     | 0 | 1     | 15            |
| 7:40 AM                         | 0                          | 0    | 0     | 0 | 0                          | 0    | 1     | 0 | 0                         | 0    | 0     | 0 | 0                         | 1    | 0     | 0 | 2     | 17            |
| 7:45 AM                         | 1                          | 0    | 0     | 0 | 0                          | 0    | 1     | 0 | 0                         | 0    | 0     | 0 | 0                         | 3    | 0     | 0 | 5     | 21            |
| 7:50 AM                         | 0                          | 0    | 0     | 0 | 0                          | 0    | 3     | 0 | 2                         | 1    | 0     | 0 | 0                         | 1    | 0     | 0 | 7     | 28            |
| 7:55 AM                         | 1                          | 0    | 0     | 0 | 0                          | 0    | 2     | 0 | 0                         | 3    | 1     | 0 | 0                         | 0    | 0     | 0 | 7     | 35            |
| 8:00 AM                         | 1                          | 0    | 0     | 0 | 0                          | 0    | 1     | 0 | 0                         | 0    | 0     | 0 | 0                         | 1    | 0     | 0 | 3     | 38            |
| 8:05 AM                         | 0                          | 0    | 0     | 0 | 0                          | 0    | 2     | 0 | 0                         | 0    | 0     | 0 | 0                         | 1    | 0     | 0 | 3     | 39            |
| 8:10 AM                         | 0                          | 0    | 0     | 0 | 0                          | 0    | 0     | 0 | 0                         | 1    | 0     | 0 | 0                         | 2    | 0     | 0 | 3     | 39            |
| 8:15 AM                         | 0                          | 0    | 0     | 0 | 0                          | 0    | 0     | 0 | 0                         | 0    | 0     | 0 | 0                         | 1    | 0     | 0 | 1     | 38            |
| 8:20 AM                         | 1                          | 0    | 0     | 0 | 0                          | 0    | 1     | 0 | 0                         | 0    | 1     | 0 | 0                         | 0    | 0     | 0 | 3     | 40            |
| 8:25 AM                         | 0                          | 0    | 0     | 0 | 0                          | 0    | 0     | 0 | 0                         | 1    | 0     | 0 | 0                         | 0    | 0     | 0 | 1     | 38            |
| 8:30 AM                         | 0                          | 0    | 0     | 0 | 0                          | 0    | 1     | 0 | 0                         | 0    | 0     | 0 | 0                         | 0    | 0     | 0 | 1     | 37            |
| 8:35 AM                         | 0                          | 0    | 0     | 0 | 0                          | 0    | 0     | 0 | 2                         | 1    | 0     | 0 | 0                         | 0    | 0     | 0 | 3     | 39            |
| 8:40 AM                         | 0                          | 0    | 0     | 0 | 0                          | 0    | 1     | 0 | 0                         | 0    | 1     | 0 | 0                         | 0    | 0     | 0 | 2     | 39            |
| 8:45 AM                         | 0                          | 0    | 0     | 0 | 0                          | 0    | 0     | 0 | 0                         | 0    | 0     | 0 | 0                         | 1    | 0     | 0 | 1     | 35            |
| 8:50 AM                         | 0                          | 0    | 0     | 0 | 0                          | 0    | 0     | 0 | 1                         | 0    | 0     | 0 | 0                         | 0    | 0     | 0 | 1     | 29            |
| 8:55 AM                         | 1                          | 0    | 0     | 0 | 0                          | 0    | 0     | 0 | 0                         | 1    | 0     | 0 | 0                         | 0    | 0     | 0 | 2     | 24            |
| 9:00 AM                         | 0                          | 0    | 0     | 0 | 0                          | 0    | 0     | 0 | 0                         | 0    | 0     | 0 | 0                         | 1    | 0     | 0 | 1     | 22            |
| 9:05 AM                         | 0                          | 0    | 1     | 0 | 0                          | 0    | 0     | 0 | 0                         | 0    | 1     | 0 | 0                         | 1    | 1     | 0 | 4     | 23            |

Attachment B

| 5-Min Count Period Beginning At | Sutherland Dr (Northbound) |      |       |   | Sutherland Dr (Southbound) |      |       |   | Sterling Glen (Eastbound) |      |       |   | Sterling Glen (Westbound) |      |       |   | Total | Hourly Totals |
|---------------------------------|----------------------------|------|-------|---|----------------------------|------|-------|---|---------------------------|------|-------|---|---------------------------|------|-------|---|-------|---------------|
|                                 | Left                       | Thru | Right | U | Left                       | Thru | Right | U | Left                      | Thru | Right | U | Left                      | Thru | Right | U |       |               |
| 9:10 AM                         | 0                          | 0    | 0     | 0 | 0                          | 0    | 0     | 0 | 2                         | 0    | 1     | 0 | 0                         | 0    | 1     | 0 | 4     | 24            |
| 9:15 AM                         | 0                          | 0    | 0     | 0 | 1                          | 0    | 1     | 0 | 0                         | 0    | 0     | 0 | 0                         | 0    | 0     | 0 | 2     | 25            |
| 9:20 AM                         | 1                          | 0    | 0     | 0 | 0                          | 0    | 0     | 0 | 0                         | 0    | 0     | 0 | 0                         | 0    | 0     | 0 | 1     | 23            |
| 9:25 AM                         | 0                          | 0    | 0     | 0 | 0                          | 0    | 1     | 0 | 0                         | 1    | 0     | 0 | 0                         | 1    | 0     | 0 | 3     | 25            |
| 9:30 AM                         | 3                          | 0    | 1     | 0 | 0                          | 0    | 2     | 0 | 1                         | 0    | 2     | 0 | 0                         | 1    | 1     | 0 | 11    | 35            |
| 9:35 AM                         | 0                          | 0    | 0     | 0 | 0                          | 0    | 1     | 0 | 0                         | 0    | 0     | 0 | 0                         | 0    | 0     | 0 | 1     | 33            |
| 9:40 AM                         | 0                          | 0    | 0     | 0 | 0                          | 0    | 0     | 0 | 0                         | 0    | 0     | 0 | 0                         | 0    | 0     | 0 | 0     | 31            |
| 9:45 AM                         | 0                          | 0    | 0     | 0 | 0                          | 0    | 0     | 0 | 2                         | 0    | 0     | 0 | 0                         | 1    | 0     | 0 | 3     | 33            |
| 9:50 AM                         | 0                          | 0    | 0     | 0 | 0                          | 0    | 0     | 0 | 2                         | 0    | 0     | 0 | 0                         | 0    | 0     | 0 | 2     | 34            |
| 9:55 AM                         | 2                          | 0    | 0     | 0 | 0                          | 0    | 2     | 0 | 1                         | 0    | 2     | 0 | 0                         | 0    | 0     | 0 | 7     | 39            |
| 10:00 AM                        | 0                          | 0    | 0     | 0 | 0                          | 0    | 1     | 0 | 0                         | 0    | 0     | 0 | 0                         | 0    | 0     | 0 | 1     | 39            |
| 10:05 AM                        | 0                          | 0    | 0     | 0 | 0                          | 0    | 0     | 0 | 0                         | 0    | 0     | 0 | 0                         | 0    | 0     | 0 | 1     | 36            |
| 10:10 AM                        | 0                          | 0    | 0     | 0 | 0                          | 0    | 0     | 0 | 0                         | 1    | 0     | 0 | 0                         | 0    | 0     | 0 | 1     | 33            |
| 10:15 AM                        | 0                          | 0    | 0     | 0 | 0                          | 0    | 1     | 0 | 0                         | 0    | 0     | 0 | 0                         | 0    | 0     | 0 | 1     | 32            |
| 10:20 AM                        | 0                          | 0    | 0     | 0 | 0                          | 0    | 2     | 0 | 1                         | 2    | 0     | 0 | 0                         | 0    | 0     | 0 | 5     | 36            |
| 10:25 AM                        | 0                          | 0    | 0     | 0 | 0                          | 0    | 2     | 0 | 0                         | 1    | 1     | 0 | 0                         | 0    | 1     | 0 | 5     | 38            |
| 10:30 AM                        | 1                          | 0    | 0     | 0 | 0                          | 0    | 0     | 0 | 1                         | 1    | 1     | 0 | 0                         | 0    | 0     | 0 | 4     | 31            |
| 10:35 AM                        | 2                          | 0    | 0     | 0 | 0                          | 0    | 1     | 0 | 0                         | 1    | 1     | 0 | 0                         | 1    | 0     | 0 | 6     | 36            |
| 10:40 AM                        | 0                          | 0    | 1     | 0 | 0                          | 0    | 1     | 0 | 0                         | 0    | 1     | 0 | 0                         | 0    | 0     | 0 | 3     | 39            |
| 10:45 AM                        | 0                          | 0    | 0     | 0 | 0                          | 0    | 2     | 0 | 0                         | 1    | 0     | 0 | 0                         | 0    | 1     | 0 | 4     | 40            |
| 10:50 AM                        | 0                          | 0    | 0     | 0 | 0                          | 0    | 1     | 0 | 0                         | 0    | 0     | 0 | 0                         | 0    | 0     | 0 | 1     | 39            |
| 10:55 AM                        | 0                          | 0    | 0     | 0 | 0                          | 0    | 0     | 0 | 0                         | 0    | 0     | 0 | 0                         | 1    | 0     | 0 | 1     | 33            |
| 11:00 AM                        | 1                          | 0    | 0     | 0 | 0                          | 0    | 0     | 0 | 1                         | 0    | 0     | 0 | 0                         | 1    | 0     | 0 | 3     | 35            |
| 11:05 AM                        | 1                          | 0    | 0     | 0 | 0                          | 0    | 0     | 0 | 1                         | 1    | 0     | 0 | 0                         | 0    | 0     | 0 | 3     | 37            |
| 11:10 AM                        | 0                          | 0    | 0     | 0 | 1                          | 0    | 0     | 0 | 2                         | 3    | 0     | 0 | 0                         | 0    | 0     | 0 | 6     | 42            |
| 11:15 AM                        | 0                          | 0    | 1     | 0 | 0                          | 0    | 0     | 0 | 0                         | 0    | 1     | 0 | 0                         | 2    | 0     | 0 | 4     | 45            |
| 11:20 AM                        | 0                          | 0    | 0     | 0 | 0                          | 0    | 1     | 0 | 1                         | 2    | 0     | 0 | 0                         | 3    | 0     | 0 | 7     | 47            |
| 11:25 AM                        | 0                          | 0    | 0     | 0 | 0                          | 0    | 0     | 0 | 2                         | 1    | 0     | 0 | 0                         | 0    | 0     | 0 | 3     | 45            |
| 11:30 AM                        | 0                          | 0    | 0     | 0 | 0                          | 0    | 0     | 0 | 0                         | 1    | 0     | 0 | 0                         | 0    | 0     | 0 | 1     | 42            |
| 11:35 AM                        | 0                          | 0    | 0     | 0 | 0                          | 0    | 0     | 0 | 1                         | 0    | 0     | 0 | 0                         | 2    | 0     | 0 | 3     | 39            |
| 11:40 AM                        | 0                          | 0    | 0     | 0 | 0                          | 0    | 0     | 0 | 0                         | 0    | 0     | 0 | 0                         | 1    | 0     | 0 | 1     | 37            |
| 11:45 AM                        | 0                          | 0    | 0     | 0 | 0                          | 0    | 0     | 0 | 0                         | 1    | 0     | 0 | 0                         | 1    | 0     | 0 | 2     | 35            |
| 11:50 AM                        | 0                          | 0    | 0     | 0 | 0                          | 0    | 1     | 0 | 0                         | 0    | 0     | 0 | 0                         | 0    | 0     | 0 | 1     | 35            |
| 11:55 AM                        | 0                          | 0    | 0     | 0 | 0                          | 0    | 0     | 0 | 1                         | 0    | 0     | 0 | 0                         | 0    | 0     | 0 | 1     | 35            |
| 12:00 PM                        | 0                          | 0    | 0     | 0 | 0                          | 0    | 0     | 0 | 1                         | 0    | 0     | 0 | 0                         | 2    | 0     | 0 | 3     | 35            |
| 12:05 PM                        | 0                          | 0    | 0     | 0 | 0                          | 0    | 1     | 0 | 1                         | 0    | 0     | 0 | 0                         | 2    | 0     | 0 | 4     | 36            |
| 12:10 PM                        | 0                          | 0    | 0     | 0 | 0                          | 0    | 2     | 0 | 0                         | 0    | 1     | 0 | 0                         | 0    | 0     | 0 | 3     | 33            |
| 12:15 PM                        | 1                          | 0    | 0     | 0 | 0                          | 0    | 1     | 0 | 0                         | 0    | 0     | 0 | 0                         | 0    | 0     | 0 | 2     | 31            |
| 12:20 PM                        | 0                          | 0    | 0     | 0 | 0                          | 0    | 0     | 0 | 0                         | 1    | 0     | 0 | 0                         | 0    | 0     | 0 | 1     | 25            |
| 12:25 PM                        | 0                          | 0    | 0     | 0 | 0                          | 0    | 2     | 0 | 1                         | 1    | 0     | 0 | 0                         | 1    | 0     | 0 | 5     | 27            |
| 12:30 PM                        | 0                          | 0    | 0     | 0 | 0                          | 0    | 0     | 0 | 0                         | 0    | 1     | 0 | 0                         | 0    | 0     | 0 | 1     | 27            |
| 12:35 PM                        | 0                          | 0    | 0     | 0 | 0                          | 0    | 1     | 0 | 1                         | 0    | 0     | 0 | 0                         | 0    | 0     | 0 | 2     | 26            |
| 12:40 PM                        | 0                          | 0    | 0     | 0 | 0                          | 0    | 0     | 0 | 0                         | 0    | 0     | 0 | 0                         | 0    | 0     | 0 | 0     | 25            |
| 12:45 PM                        | 0                          | 0    | 0     | 0 | 0                          | 0    | 1     | 0 | 0                         | 0    | 2     | 0 | 0                         | 0    | 0     | 0 | 3     | 26            |
| 12:50 PM                        | 1                          | 0    | 1     | 0 | 0                          | 0    | 2     | 0 | 0                         | 0    | 0     | 0 | 0                         | 0    | 0     | 0 | 4     | 29            |
| 12:55 PM                        | 1                          | 0    | 0     | 0 | 0                          | 0    | 1     | 0 | 0                         | 0    | 0     | 0 | 0                         | 0    | 1     | 0 | 3     | 31            |
| 1:00 PM                         | 0                          | 0    | 0     | 0 | 0                          | 0    | 0     | 0 | 1                         | 0    | 0     | 0 | 0                         | 0    | 0     | 0 | 1     | 29            |
| 1:05 PM                         | 0                          | 0    | 0     | 0 | 0                          | 0    | 1     | 0 | 0                         | 2    | 2     | 0 | 0                         | 1    | 0     | 0 | 6     | 31            |
| 1:10 PM                         | 0                          | 0    | 0     | 0 | 0                          | 0    | 0     | 0 | 1                         | 3    | 0     | 0 | 0                         | 1    | 0     | 0 | 5     | 33            |
| 1:15 PM                         | 1                          | 0    | 0     | 0 | 1                          | 0    | 0     | 0 | 1                         | 2    | 0     | 0 | 0                         | 1    | 0     | 0 | 6     | 37            |
| 1:20 PM                         | 1                          | 0    | 0     | 0 | 0                          | 0    | 0     | 0 | 0                         | 1    | 0     | 0 | 0                         | 3    | 0     | 0 | 5     | 41            |
| 1:25 PM                         | 0                          | 0    | 0     | 0 | 0                          | 0    | 0     | 0 | 0                         | 0    | 0     | 0 | 0                         | 1    | 0     | 0 | 1     | 37            |
| 1:30 PM                         | 0                          | 0    | 0     | 0 | 0                          | 0    | 1     | 0 | 0                         | 2    | 0     | 0 | 0                         | 0    | 0     | 0 | 3     | 39            |
| 1:35 PM                         | 0                          | 0    | 0     | 0 | 0                          | 0    | 2     | 0 | 0                         | 1    | 0     | 0 | 0                         | 1    | 0     | 0 | 4     | 41            |
| 1:40 PM                         | 0                          | 0    | 0     | 0 | 0                          | 0    | 0     | 0 | 0                         | 1    | 0     | 0 | 0                         | 0    | 0     | 0 | 1     | 42            |
| 1:45 PM                         | 0                          | 0    | 0     | 0 | 0                          | 0    | 1     | 0 | 1                         | 1    | 0     | 0 | 0                         | 1    | 0     | 0 | 4     | 43            |
| 1:50 PM                         | 0                          | 0    | 0     | 0 | 0                          | 0    | 0     | 0 | 1                         | 0    | 0     | 0 | 0                         | 1    | 0     | 0 | 2     | 41            |
| 1:55 PM                         | 0                          | 0    | 0     | 0 | 0                          | 0    | 0     | 0 | 0                         | 0    | 0     | 0 | 0                         | 1    | 0     | 0 | 1     | 39            |
| 2:00 PM                         | 0                          | 0    | 0     | 0 | 0                          | 0    | 0     | 0 | 1                         | 0    | 1     | 0 | 0                         | 0    | 0     | 0 | 2     | 40            |
| 2:05 PM                         | 0                          | 0    | 0     | 0 | 0                          | 0    | 0     | 0 | 1                         | 1    | 0     | 0 | 0                         | 1    | 0     | 0 | 3     | 37            |
| 2:10 PM                         | 0                          | 0    | 0     | 0 | 0                          | 0    | 1     | 0 | 2                         | 0    | 0     | 0 | 0                         | 0    | 0     | 0 | 3     | 35            |
| 2:15 PM                         | 0                          | 0    | 0     | 0 | 0                          | 0    | 0     | 0 | 0                         | 0    | 0     | 0 | 0                         | 0    | 0     | 0 | 0     | 29            |
| 2:20 PM                         | 1                          | 0    | 0     | 0 | 0                          | 0    | 0     | 0 | 1                         | 0    | 0     | 0 | 0                         | 0    | 0     | 0 | 2     | 26            |
| 2:25 PM                         | 0                          | 0    | 0     | 0 | 0                          | 0    | 0     | 0 | 1                         | 0    | 1     | 0 | 0                         | 0    | 0     | 0 | 2     | 27            |
| 2:30 PM                         | 0                          | 0    | 0     | 0 | 0                          | 0    | 1     | 0 | 2                         | 0    | 0     | 0 | 0                         | 2    | 0     | 0 | 5     | 29            |
| 2:35 PM                         | 0                          | 0    | 0     | 0 | 0                          | 0    | 1     | 0 | 0                         | 2    | 0     | 0 | 0                         | 1    | 0     | 0 | 4     | 29            |
| 2:40 PM                         | 1                          | 0    | 0     | 0 | 0                          | 0    | 1     | 0 | 1                         | 0    | 2     | 0 | 0                         | 0    | 0     | 0 | 5     | 33            |
| 2:45 PM                         | 0                          | 0    | 0     | 0 | 0                          | 0    | 1     | 0 | 0                         | 0    | 0     | 0 | 0                         | 0    | 0     | 0 | 1     | 30            |
| 2:50 PM                         | 0                          | 0    | 0     | 0 | 0                          | 0    | 0     | 0 | 1                         | 0    | 0     | 0 | 0                         | 0    | 0     | 0 | 1     | 29            |
| 2:55 PM                         | 0                          | 0    | 0     | 0 | 0                          | 0    | 0     | 0 | 0                         | 0    | 0     | 0 | 0                         | 0    | 0     | 0 | 0     | 28            |
| 3:00 PM                         | 0                          | 0    | 0     | 0 | 0                          | 0    | 1     | 0 | 3                         | 2    | 0     | 0 | 0                         | 0    | 0     | 0 | 6     | 32            |
| 3:05 PM                         | 1                          | 0    | 0     | 0 | 0                          | 0    | 0     | 0 | 1                         | 1    | 0     | 0 | 0                         | 0    | 0     | 0 | 3     | 32            |
| 3:10 PM                         | 0                          | 0    | 0     | 0 | 0                          | 0    | 2     | 0 | 1                         | 1    | 0     | 0 | 0                         | 1    | 0     | 0 | 5     | 34            |
| 3:15 PM                         | 0                          | 0    | 0     | 0 | 0                          | 0    | 0     | 0 | 0                         | 2    | 1     | 0 | 0                         | 0    | 0     | 0 | 4     | 38            |
| 3:20 PM                         | 0                          | 0    | 0     | 0 | 0                          | 0    | 1     | 0 | 0                         | 0    | 0     | 0 | 0                         | 0    | 0     | 0 | 1     | 37            |
| 3:25 PM                         | 0                          | 0    | 0     | 0 | 0                          | 0    | 1     | 0 | 0                         | 7    | 1     | 0 | 0                         | 0    | 2     | 0 | 11    | 46            |
| 3:30 PM                         | 1                          | 0    | 0     | 0 | 0                          | 0    | 1     | 0 | 0                         | 1    | 0     | 0 | 0                         | 1    | 0     | 0 | 4     | 45            |
| 3:35 PM                         | 1                          | 0    | 0     | 0 | 0                          | 0    | 1     | 0 | 0                         | 1    | 1     | 0 | 0                         | 0    | 1     | 0 | 5     | 46            |
| 3:40 PM                         | 0                          | 1    | 0     | 0 | 0                          | 0    | 0     | 0 | 1                         | 2    | 0     | 0 | 0                         | 1    | 0     | 0 | 5     | 46            |
| 3:45 PM                         | 0                          | 0    | 0     | 0 | 0                          | 0    | 0     | 0 | 0                         | 0    | 0     | 0 | 0                         | 1    | 0     | 0 | 1     | 46            |
| 3:50 PM                         | 0                          | 0    | 0     | 0 | 1                          | 0    | 1     | 0 | 1                         | 1    | 1     | 0 | 0                         | 2    | 0     | 0 | 7     | 52            |
| 3:55 PM                         | 0                          | 0    | 0     | 0 | 0                          | 0    | 0     | 0 | 0                         | 0    | 0     | 0 | 0                         | 1    | 0     | 0 | 1     | 53            |
| 4:00 PM                         | 0                          | 0    | 0     | 0 | 0                          | 0    | 0     | 0 | 1                         | 2    | 1     | 0 | 0                         | 0    | 0     | 0 | 4     | 51            |
| 4:05 PM                         | 1                          | 0    | 0     | 0 | 0                          | 0    | 0     | 0 | 0                         | 1    | 1     | 0 | 0                         | 2    | 0     | 0 | 5     | 53            |
| 4:10 PM                         | 1                          | 0    | 0     | 0 | 0                          | 0    | 1     | 0 | 2                         | 0    | 0     | 0 | 0                         | 1    | 0     | 0 | 5     | 53            |
| 4:15 PM                         | 0                          | 0    | 0     | 0 | 0                          | 0    | 0     | 0 | 0                         | 0    | 0     | 0 | 0                         | 0    | 0     | 0 | 0     | 49            |
| 4:20 PM                         | 0                          | 0    | 0     | 0 | 0                          | 0    | 0     | 0 | 1                         | 1    | 0     | 0 | 0                         | 1    | 0     | 0 | 3     | 51            |
| 4:25 PM                         | 1                          | 0    | 0     | 0 | 0                          | 0    | 1     | 0 | 0                         | 1    | 0     | 0 | 0                         | 2    | 0     | 0 | 5     | 45            |

**Attachment B**

| 5-Min Count Period Beginning At | Sutherland Dr (Northbound) |      |       |   | Sutherland Dr (Southbound) |      |       |   | Sterling Glen (Eastbound) |      |       |   | Sterling Glen (Westbound) |      |       |   | Total | Hourly Totals |
|---------------------------------|----------------------------|------|-------|---|----------------------------|------|-------|---|---------------------------|------|-------|---|---------------------------|------|-------|---|-------|---------------|
|                                 | Left                       | Thru | Right | U | Left                       | Thru | Right | U | Left                      | Thru | Right | U | Left                      | Thru | Right | U |       |               |
| 4:30 PM                         | 0                          | 0    | 0     | 0 | 0                          | 0    | 0     | 0 | 0                         | 2    | 0     | 0 | 0                         | 1    | 0     | 0 | 3     | 44            |
| 4:35 PM                         | 1                          | 0    | 0     | 0 | 0                          | 0    | 0     | 0 | 1                         | 0    | 2     | 0 | 0                         | 0    | 0     | 0 | 4     | 43            |
| 4:40 PM                         | 1                          | 0    | 0     | 0 | 0                          | 0    | 0     | 0 | 0                         | 0    | 0     | 0 | 0                         | 2    | 0     | 0 | 3     | 41            |
| 4:45 PM                         | 0                          | 0    | 0     | 0 | 0                          | 0    | 1     | 0 | 0                         | 0    | 0     | 0 | 0                         | 0    | 0     | 0 | 1     | 41            |
| 4:50 PM                         | 0                          | 0    | 0     | 0 | 0                          | 0    | 0     | 0 | 1                         | 1    | 1     | 0 | 0                         | 0    | 0     | 0 | 3     | 37            |
| 4:55 PM                         | 0                          | 0    | 0     | 0 | 0                          | 0    | 0     | 0 | 0                         | 1    | 0     | 0 | 0                         | 0    | 0     | 0 | 1     | 37            |
| 5:00 PM                         | 0                          | 0    | 0     | 0 | 0                          | 0    | 1     | 0 | 1                         | 1    | 0     | 0 | 0                         | 0    | 0     | 0 | 3     | 36            |
| 5:05 PM                         | 0                          | 0    | 0     | 0 | 0                          | 0    | 0     | 0 | 0                         | 4    | 0     | 0 | 0                         | 0    | 0     | 0 | 4     | 35            |
| 5:10 PM                         | 0                          | 0    | 0     | 0 | 0                          | 0    | 0     | 0 | 1                         | 0    | 1     | 0 | 0                         | 0    | 0     | 0 | 2     | 32            |
| 5:15 PM                         | 2                          | 0    | 0     | 0 | 0                          | 0    | 0     | 0 | 0                         | 1    | 0     | 0 | 0                         | 1    | 0     | 0 | 4     | 36            |
| 5:20 PM                         | 0                          | 0    | 0     | 0 | 0                          | 0    | 1     | 0 | 1                         | 0    | 1     | 0 | 0                         | 3    | 0     | 0 | 6     | 39            |
| 5:25 PM                         | 0                          | 0    | 0     | 0 | 0                          | 0    | 0     | 0 | 0                         | 0    | 1     | 0 | 0                         | 1    | 0     | 0 | 2     | 36            |
| 5:30 PM                         | 0                          | 0    | 0     | 0 | 0                          | 0    | 0     | 0 | 0                         | 1    | 0     | 0 | 0                         | 2    | 0     | 0 | 3     | 36            |
| 5:35 PM                         | 0                          | 0    | 0     | 0 | 0                          | 0    | 2     | 0 | 0                         | 2    | 0     | 0 | 0                         | 2    | 0     | 0 | 6     | 38            |
| 5:40 PM                         | 0                          | 0    | 0     | 0 | 0                          | 0    | 0     | 0 | 0                         | 3    | 2     | 0 | 0                         | 1    | 0     | 0 | 6     | 41            |
| 5:45 PM                         | 0                          | 0    | 0     | 0 | 0                          | 0    | 1     | 0 | 0                         | 0    | 1     | 0 | 0                         | 0    | 0     | 0 | 2     | 42            |
| 5:50 PM                         | 0                          | 0    | 0     | 0 | 0                          | 0    | 0     | 0 | 2                         | 1    | 0     | 0 | 0                         | 0    | 0     | 0 | 3     | 42            |
| 5:55 PM                         | 0                          | 0    | 0     | 0 | 0                          | 0    | 0     | 0 | 0                         | 0    | 0     | 0 | 0                         | 1    | 0     | 0 | 1     | 42            |
| 6:00 PM                         | 0                          | 0    | 0     | 0 | 0                          | 0    | 0     | 0 | 1                         | 1    | 0     | 0 | 0                         | 2    | 0     | 0 | 4     | 43            |
| 6:05 PM                         | 0                          | 0    | 0     | 0 | 0                          | 0    | 0     | 0 | 1                         | 0    | 1     | 0 | 0                         | 2    | 0     | 0 | 4     | 43            |
| 6:10 PM                         | 0                          | 0    | 0     | 0 | 0                          | 0    | 1     | 0 | 0                         | 1    | 0     | 0 | 0                         | 2    | 0     | 0 | 4     | 45            |
| 6:15 PM                         | 1                          | 0    | 0     | 0 | 0                          | 0    | 0     | 0 | 0                         | 1    | 0     | 0 | 0                         | 1    | 0     | 0 | 3     | 44            |
| 6:20 PM                         | 0                          | 0    | 0     | 0 | 0                          | 0    | 0     | 0 | 0                         | 2    | 0     | 0 | 0                         | 1    | 0     | 0 | 3     | 41            |
| 6:25 PM                         | 0                          | 0    | 0     | 0 | 0                          | 0    | 1     | 0 | 2                         | 2    | 0     | 0 | 0                         | 2    | 0     | 0 | 7     | 46            |
| 6:30 PM                         | 0                          | 0    | 0     | 0 | 0                          | 0    | 0     | 0 | 1                         | 0    | 0     | 0 | 0                         | 0    | 0     | 0 | 1     | 44            |
| 6:35 PM                         | 0                          | 0    | 0     | 0 | 0                          | 0    | 0     | 0 | 0                         | 2    | 1     | 0 | 0                         | 0    | 0     | 0 | 3     | 41            |
| 6:40 PM                         | 0                          | 0    | 0     | 0 | 0                          | 0    | 0     | 0 | 1                         | 0    | 0     | 0 | 0                         | 0    | 0     | 0 | 1     | 36            |
| 6:45 PM                         | 0                          | 0    | 0     | 0 | 0                          | 0    | 2     | 0 | 0                         | 1    | 1     | 0 | 0                         | 0    | 0     | 0 | 4     | 38            |
| 6:50 PM                         | 1                          | 0    | 0     | 0 | 0                          | 0    | 0     | 0 | 0                         | 1    | 1     | 0 | 0                         | 2    | 0     | 0 | 5     | 40            |
| 6:55 PM                         | 0                          | 0    | 0     | 0 | 0                          | 0    | 0     | 0 | 0                         | 0    | 0     | 0 | 0                         | 1    | 0     | 0 | 1     | 40            |
| 7:00 PM                         | 1                          | 0    | 0     | 0 | 0                          | 0    | 0     | 0 | 1                         | 1    | 0     | 0 | 0                         | 0    | 0     | 0 | 3     | 39            |
| 7:05 PM                         | 0                          | 0    | 0     | 0 | 0                          | 0    | 0     | 0 | 1                         | 2    | 0     | 0 | 0                         | 1    | 0     | 0 | 4     | 39            |
| 7:10 PM                         | 0                          | 0    | 0     | 0 | 0                          | 0    | 0     | 0 | 1                         | 0    | 1     | 0 | 0                         | 1    | 0     | 0 | 3     | 38            |
| 7:15 PM                         | 0                          | 0    | 0     | 0 | 0                          | 0    | 0     | 0 | 0                         | 1    | 1     | 0 | 0                         | 1    | 0     | 0 | 3     | 38            |
| 7:20 PM                         | 0                          | 0    | 0     | 0 | 0                          | 0    | 1     | 0 | 1                         | 0    | 0     | 0 | 0                         | 0    | 0     | 0 | 2     | 37            |
| 7:25 PM                         | 0                          | 0    | 0     | 0 | 0                          | 0    | 0     | 0 | 0                         | 0    | 0     | 0 | 0                         | 0    | 0     | 0 | 0     | 30            |
| 7:30 PM                         | 0                          | 0    | 0     | 0 | 0                          | 0    | 0     | 0 | 0                         | 2    | 0     | 0 | 0                         | 0    | 0     | 0 | 2     | 31            |
| 7:35 PM                         | 0                          | 0    | 0     | 0 | 0                          | 0    | 0     | 0 | 0                         | 0    | 0     | 0 | 0                         | 1    | 0     | 0 | 1     | 29            |
| 7:40 PM                         | 0                          | 0    | 0     | 0 | 0                          | 0    | 0     | 0 | 0                         | 0    | 0     | 0 | 0                         | 0    | 0     | 0 | 0     | 28            |
| 7:45 PM                         | 0                          | 0    | 0     | 0 | 0                          | 0    | 1     | 0 | 0                         | 0    | 0     | 0 | 0                         | 0    | 0     | 0 | 1     | 25            |
| 7:50 PM                         | 0                          | 0    | 0     | 0 | 0                          | 0    | 0     | 0 | 0                         | 1    | 0     | 0 | 0                         | 0    | 0     | 0 | 1     | 21            |
| 7:55 PM                         | 0                          | 1    | 0     | 0 | 0                          | 1    | 0     | 0 | 0                         | 2    | 0     | 0 | 0                         | 0    | 0     | 0 | 4     | 24            |
| 8:00 PM                         | 0                          | 0    | 0     | 0 | 1                          | 0    | 1     | 0 | 1                         | 0    | 0     | 0 | 0                         | 1    | 1     | 0 | 5     | 26            |
| 8:05 PM                         | 0                          | 0    | 0     | 0 | 0                          | 0    | 1     | 0 | 1                         | 0    | 0     | 0 | 0                         | 0    | 0     | 0 | 2     | 24            |
| 8:10 PM                         | 0                          | 0    | 0     | 0 | 0                          | 0    | 0     | 0 | 1                         | 0    | 0     | 0 | 0                         | 0    | 0     | 0 | 1     | 22            |
| 8:15 PM                         | 0                          | 0    | 0     | 0 | 0                          | 0    | 0     | 0 | 0                         | 1    | 0     | 0 | 0                         | 0    | 0     | 0 | 1     | 20            |
| 8:20 PM                         | 0                          | 0    | 0     | 0 | 0                          | 0    | 0     | 0 | 1                         | 0    | 0     | 0 | 0                         | 0    | 0     | 0 | 1     | 19            |
| 8:25 PM                         | 0                          | 0    | 0     | 0 | 0                          | 0    | 1     | 0 | 0                         | 1    | 0     | 0 | 0                         | 0    | 0     | 0 | 2     | 21            |
| 8:30 PM                         | 0                          | 0    | 0     | 0 | 0                          | 0    | 0     | 0 | 0                         | 0    | 0     | 0 | 0                         | 0    | 0     | 0 | 0     | 19            |
| 8:35 PM                         | 0                          | 0    | 0     | 0 | 0                          | 0    | 0     | 0 | 2                         | 2    | 0     | 0 | 0                         | 1    | 0     | 0 | 5     | 23            |
| 8:40 PM                         | 0                          | 0    | 0     | 0 | 0                          | 0    | 0     | 0 | 1                         | 2    | 0     | 0 | 0                         | 1    | 0     | 0 | 4     | 27            |
| 8:45 PM                         | 0                          | 0    | 0     | 0 | 0                          | 0    | 0     | 0 | 0                         | 0    | 0     | 0 | 0                         | 0    | 0     | 0 | 0     | 26            |
| 8:50 PM                         | 0                          | 0    | 0     | 0 | 0                          | 0    | 0     | 0 | 0                         | 0    | 0     | 0 | 0                         | 0    | 0     | 0 | 0     | 25            |
| 8:55 PM                         | 0                          | 0    | 0     | 0 | 0                          | 0    | 1     | 0 | 0                         | 0    | 0     | 0 | 0                         | 0    | 0     | 0 | 1     | 22            |
| 9:00 PM                         | 0                          | 0    | 0     | 0 | 0                          | 0    | 0     | 0 | 0                         | 1    | 0     | 0 | 0                         | 0    | 0     | 0 | 1     | 18            |
| 9:05 PM                         | 0                          | 0    | 0     | 0 | 0                          | 0    | 0     | 0 | 0                         | 0    | 0     | 0 | 0                         | 0    | 0     | 0 | 0     | 16            |
| 9:10 PM                         | 0                          | 0    | 0     | 0 | 0                          | 0    | 0     | 0 | 0                         | 1    | 0     | 0 | 0                         | 0    | 0     | 0 | 1     | 16            |
| 9:15 PM                         | 0                          | 0    | 0     | 0 | 0                          | 0    | 0     | 0 | 1                         | 0    | 0     | 0 | 0                         | 0    | 0     | 0 | 1     | 16            |
| 9:20 PM                         | 0                          | 0    | 0     | 0 | 0                          | 0    | 0     | 0 | 1                         | 1    | 1     | 0 | 0                         | 1    | 0     | 0 | 4     | 19            |
| 9:25 PM                         | 0                          | 1    | 0     | 0 | 0                          | 0    | 2     | 0 | 1                         | 0    | 0     | 0 | 0                         | 0    | 0     | 0 | 4     | 21            |
| 9:30 PM                         | 0                          | 0    | 0     | 0 | 0                          | 0    | 0     | 0 | 0                         | 1    | 0     | 0 | 0                         | 0    | 0     | 0 | 1     | 22            |
| 9:35 PM                         | 0                          | 0    | 0     | 0 | 0                          | 0    | 0     | 0 | 0                         | 0    | 0     | 0 | 0                         | 1    | 0     | 0 | 1     | 18            |
| 9:40 PM                         | 0                          | 0    | 0     | 0 | 0                          | 0    | 0     | 0 | 0                         | 0    | 0     | 0 | 0                         | 0    | 0     | 0 | 0     | 14            |
| 9:45 PM                         | 0                          | 0    | 0     | 0 | 0                          | 0    | 0     | 0 | 0                         | 0    | 0     | 0 | 0                         | 0    | 0     | 0 | 0     | 14            |
| 9:50 PM                         | 0                          | 0    | 0     | 0 | 0                          | 0    | 0     | 0 | 0                         | 1    | 0     | 0 | 0                         | 0    | 0     | 0 | 1     | 15            |
| 9:55 PM                         | 0                          | 0    | 0     | 0 | 0                          | 0    | 0     | 0 | 0                         | 0    | 0     | 0 | 0                         | 0    | 0     | 0 | 0     | 14            |
| Peak 15-Min Flowrates           | Northbound                 |      |       |   | Southbound                 |      |       |   | Eastbound                 |      |       |   | Westbound                 |      |       |   | Total |               |
|                                 | Left                       | Thru | Right | U | Left                       | Thru | Right | U | Left                      | Thru | Right | U | Left                      | Thru | Right | U |       |               |
| All Vehicles                    | 8                          | 0    | 0     | 0 | 0                          | 0    | 12    | 0 | 0                         | 36   | 8     | 0 | 0                         | 16   | 0     | 0 | 80    |               |
| Heavy Trucks                    | 0                          | 0    | 0     | 0 | 0                          | 0    | 0     | 0 | 0                         | 0    | 4     | 0 | 0                         | 0    | 0     | 0 | 4     |               |
| Buses                           |                            |      |       |   |                            |      |       |   |                           |      |       |   |                           |      |       |   |       |               |
| Pedestrians                     |                            | 0    |       |   |                            | 0    |       |   |                           | 0    |       |   |                           | 0    |       |   | 0     |               |
| Bicycles                        | 0                          | 0    | 0     |   | 0                          | 0    | 0     |   | 0                         | 0    | 0     |   | 0                         | 0    | 0     |   | 0     |               |
| Scoters                         |                            |      |       |   |                            |      |       |   |                           |      |       |   |                           |      |       |   |       |               |
| <i>Comments:</i>                |                            |      |       |   |                            |      |       |   |                           |      |       |   |                           |      |       |   |       |               |

Type of peak hour being reported: Intersection Peak

Method for determining peak hour: Total Entering Volume

LOCATION: Magnolia Dr -- Blue Spruce Dr  
 CITY/STATE: Ladera Ranch, CA

QC JOB #: 16966462  
 DATE: Wed, Apr 16 2025

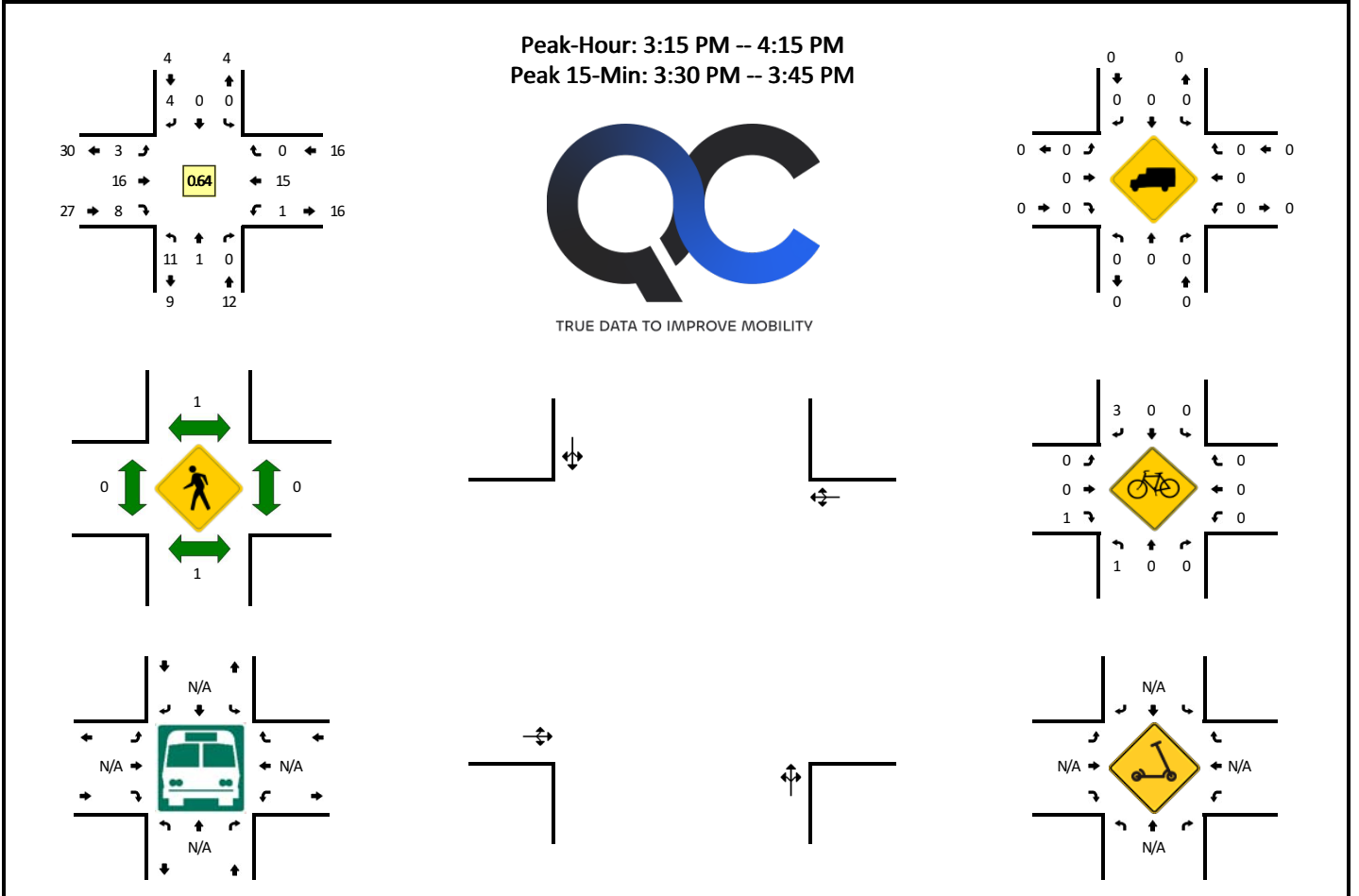

| 5-Min Count Period Beginning At | Magnolia Dr (Northbound) |      |       |   | Magnolia Dr (Southbound) |      |       |   | Blue Spruce Dr (Eastbound) |      |       |   | Blue Spruce Dr (Westbound) |      |       |   | Total | Hourly Totals |
|---------------------------------|--------------------------|------|-------|---|--------------------------|------|-------|---|----------------------------|------|-------|---|----------------------------|------|-------|---|-------|---------------|
|                                 | Left                     | Thru | Right | U | Left                     | Thru | Right | U | Left                       | Thru | Right | U | Left                       | Thru | Right | U |       |               |
| 6:00 AM                         | 0                        | 0    | 0     | 0 | 0                        | 0    | 0     | 0 | 0                          | 0    | 1     | 0 | 0                          | 0    | 0     | 0 | 2     |               |
| 6:05 AM                         | 0                        | 0    | 0     | 0 | 0                        | 0    | 0     | 0 | 0                          | 0    | 0     | 0 | 0                          | 0    | 0     | 0 | 0     |               |
| 6:10 AM                         | 0                        | 0    | 0     | 0 | 0                        | 0    | 0     | 0 | 0                          | 0    | 0     | 0 | 0                          | 0    | 0     | 0 | 0     |               |
| 6:15 AM                         | 0                        | 0    | 0     | 0 | 0                        | 0    | 1     | 0 | 0                          | 0    | 0     | 0 | 0                          | 0    | 0     | 0 | 1     |               |
| 6:20 AM                         | 0                        | 0    | 0     | 0 | 0                        | 0    | 0     | 0 | 0                          | 0    | 1     | 0 | 0                          | 0    | 0     | 0 | 1     |               |
| 6:25 AM                         | 1                        | 0    | 0     | 0 | 0                        | 0    | 0     | 0 | 0                          | 0    | 0     | 0 | 0                          | 0    | 1     | 0 | 2     |               |
| 6:30 AM                         | 0                        | 0    | 0     | 0 | 0                        | 0    | 0     | 0 | 0                          | 0    | 0     | 0 | 0                          | 0    | 0     | 0 | 0     |               |
| 6:35 AM                         | 0                        | 0    | 0     | 0 | 0                        | 0    | 0     | 0 | 0                          | 0    | 0     | 0 | 0                          | 0    | 0     | 0 | 0     |               |
| 6:40 AM                         | 0                        | 0    | 0     | 0 | 0                        | 0    | 0     | 0 | 0                          | 0    | 0     | 0 | 0                          | 0    | 0     | 0 | 0     |               |
| 6:45 AM                         | 0                        | 0    | 0     | 0 | 0                        | 0    | 0     | 0 | 0                          | 0    | 1     | 0 | 0                          | 0    | 0     | 0 | 1     |               |
| 6:50 AM                         | 0                        | 0    | 0     | 0 | 0                        | 0    | 0     | 0 | 0                          | 0    | 1     | 0 | 0                          | 0    | 0     | 1 | 2     |               |
| 6:55 AM                         | 0                        | 0    | 0     | 0 | 0                        | 0    | 0     | 0 | 0                          | 0    | 0     | 0 | 0                          | 0    | 3     | 0 | 3     | 12            |
| 7:00 AM                         | 0                        | 0    | 0     | 0 | 0                        | 0    | 0     | 0 | 0                          | 0    | 0     | 0 | 0                          | 0    | 0     | 0 | 0     | 10            |
| 7:05 AM                         | 0                        | 0    | 0     | 0 | 0                        | 0    | 0     | 0 | 0                          | 1    | 0     | 0 | 0                          | 0    | 2     | 0 | 3     | 13            |
| 7:10 AM                         | 1                        | 0    | 0     | 0 | 0                        | 0    | 0     | 0 | 0                          | 0    | 1     | 0 | 0                          | 0    | 1     | 0 | 3     | 16            |
| 7:15 AM                         | 0                        | 0    | 0     | 0 | 0                        | 0    | 0     | 0 | 0                          | 0    | 1     | 0 | 0                          | 0    | 2     | 0 | 3     | 18            |
| 7:20 AM                         | 0                        | 0    | 0     | 0 | 0                        | 0    | 0     | 0 | 0                          | 0    | 1     | 1 | 0                          | 0    | 0     | 0 | 2     | 19            |
| 7:25 AM                         | 0                        | 0    | 0     | 0 | 0                        | 0    | 0     | 0 | 0                          | 0    | 0     | 0 | 0                          | 0    | 2     | 0 | 2     | 19            |
| 7:30 AM                         | 0                        | 0    | 0     | 0 | 0                        | 0    | 0     | 0 | 0                          | 0    | 1     | 0 | 0                          | 0    | 1     | 0 | 2     | 21            |
| 7:35 AM                         | 0                        | 0    | 0     | 0 | 0                        | 0    | 0     | 0 | 0                          | 0    | 0     | 0 | 0                          | 0    | 4     | 0 | 4     | 25            |
| 7:40 AM                         | 2                        | 0    | 0     | 0 | 0                        | 0    | 1     | 0 | 0                          | 0    | 1     | 0 | 0                          | 0    | 0     | 0 | 4     | 29            |
| 7:45 AM                         | 2                        | 0    | 0     | 0 | 0                        | 0    | 0     | 0 | 0                          | 0    | 0     | 0 | 0                          | 0    | 1     | 0 | 3     | 31            |
| 7:50 AM                         | 1                        | 0    | 0     | 0 | 0                        | 0    | 0     | 0 | 0                          | 0    | 1     | 1 | 0                          | 0    | 1     | 0 | 4     | 33            |
| 7:55 AM                         | 0                        | 0    | 0     | 0 | 0                        | 0    | 0     | 0 | 0                          | 0    | 0     | 0 | 0                          | 0    | 3     | 0 | 3     | 33            |
| 8:00 AM                         | 0                        | 0    | 0     | 0 | 0                        | 0    | 0     | 0 | 0                          | 0    | 1     | 0 | 0                          | 0    | 1     | 0 | 2     | 35            |
| 8:05 AM                         | 1                        | 0    | 0     | 0 | 0                        | 0    | 0     | 0 | 0                          | 0    | 1     | 0 | 0                          | 0    | 2     | 0 | 4     | 36            |
| 8:10 AM                         | 0                        | 0    | 0     | 0 | 0                        | 0    | 0     | 0 | 0                          | 1    | 0     | 0 | 0                          | 0    | 1     | 0 | 2     | 35            |
| 8:15 AM                         | 1                        | 0    | 0     | 0 | 0                        | 0    | 1     | 0 | 0                          | 0    | 1     | 0 | 0                          | 0    | 0     | 0 | 3     | 35            |
| 8:20 AM                         | 1                        | 0    | 0     | 0 | 0                        | 0    | 0     | 0 | 0                          | 0    | 1     | 0 | 0                          | 0    | 0     | 0 | 2     | 35            |
| 8:25 AM                         | 0                        | 0    | 0     | 0 | 0                        | 0    | 0     | 0 | 0                          | 0    | 2     | 0 | 0                          | 0    | 0     | 0 | 2     | 35            |
| 8:30 AM                         | 0                        | 0    | 0     | 0 | 0                        | 0    | 1     | 0 | 0                          | 0    | 0     | 0 | 0                          | 0    | 0     | 0 | 1     | 34            |
| 8:35 AM                         | 0                        | 0    | 0     | 0 | 0                        | 0    | 0     | 0 | 0                          | 1    | 0     | 0 | 0                          | 0    | 1     | 0 | 2     | 32            |
| 8:40 AM                         | 1                        | 0    | 0     | 0 | 0                        | 0    | 0     | 0 | 0                          | 0    | 0     | 0 | 0                          | 0    | 0     | 0 | 1     | 29            |
| 8:45 AM                         | 0                        | 0    | 0     | 0 | 0                        | 0    | 0     | 0 | 0                          | 0    | 0     | 0 | 0                          | 0    | 0     | 0 | 0     | 26            |
| 8:50 AM                         | 0                        | 0    | 1     | 0 | 0                        | 0    | 0     | 0 | 0                          | 0    | 1     | 1 | 0                          | 0    | 0     | 0 | 3     | 25            |
| 8:55 AM                         | 0                        | 0    | 0     | 0 | 1                        | 0    | 0     | 0 | 0                          | 1    | 0     | 1 | 0                          | 0    | 2     | 0 | 5     | 27            |
| 9:00 AM                         | 0                        | 0    | 0     | 0 | 0                        | 0    | 1     | 0 | 0                          | 0    | 1     | 0 | 0                          | 0    | 1     | 1 | 4     | 29            |
| 9:05 AM                         | 0                        | 0    | 0     | 0 | 0                        | 0    | 0     | 0 | 0                          | 0    | 0     | 0 | 0                          | 0    | 0     | 0 | 0     | 25            |

Attachment B

| 5-Min Count<br>Period<br>Beginning At | Magnolia Dr<br>(Northbound) |      |       |   | Magnolia Dr<br>(Southbound) |      |       |   | Blue Spruce Dr<br>(Eastbound) |      |       |   | Blue Spruce Dr<br>(Westbound) |      |       |   | Total | Hourly<br>Totals |    |
|---------------------------------------|-----------------------------|------|-------|---|-----------------------------|------|-------|---|-------------------------------|------|-------|---|-------------------------------|------|-------|---|-------|------------------|----|
|                                       | Left                        | Thru | Right | U | Left                        | Thru | Right | U | Left                          | Thru | Right | U | Left                          | Thru | Right | U |       |                  |    |
| 9:10 AM                               | 1                           | 0    | 0     | 0 | 0                           | 0    | 0     | 0 | 0                             | 0    | 0     | 0 | 0                             | 1    | 0     | 0 | 0     | 2                | 25 |
| 9:15 AM                               | 0                           | 0    | 0     | 0 | 0                           | 0    | 0     | 0 | 0                             | 0    | 1     | 0 | 0                             | 0    | 0     | 0 | 0     | 1                | 23 |
| 9:20 AM                               | 0                           | 0    | 0     | 0 | 0                           | 0    | 0     | 0 | 0                             | 0    | 1     | 0 | 0                             | 0    | 0     | 1 | 0     | 2                | 23 |
| 9:25 AM                               | 1                           | 0    | 0     | 0 | 0                           | 0    | 0     | 0 | 0                             | 0    | 1     | 0 | 0                             | 0    | 3     | 0 | 0     | 5                | 26 |
| 9:30 AM                               | 1                           | 0    | 0     | 0 | 1                           | 0    | 2     | 0 | 0                             | 0    | 0     | 0 | 0                             | 0    | 0     | 0 | 0     | 4                | 29 |
| 9:35 AM                               | 1                           | 0    | 0     | 0 | 0                           | 0    | 0     | 0 | 0                             | 0    | 0     | 0 | 0                             | 0    | 0     | 0 | 0     | 1                | 28 |
| 9:40 AM                               | 0                           | 0    | 0     | 0 | 0                           | 0    | 0     | 0 | 0                             | 0    | 0     | 0 | 0                             | 0    | 0     | 0 | 0     | 0                | 27 |
| 9:45 AM                               | 1                           | 0    | 0     | 0 | 0                           | 0    | 0     | 0 | 1                             | 1    | 0     | 0 | 0                             | 1    | 0     | 0 | 0     | 4                | 31 |
| 9:50 AM                               | 0                           | 0    | 0     | 0 | 0                           | 0    | 1     | 0 | 0                             | 0    | 1     | 0 | 0                             | 0    | 3     | 0 | 0     | 5                | 33 |
| 9:55 AM                               | 1                           | 0    | 0     | 0 | 0                           | 0    | 0     | 0 | 0                             | 0    | 1     | 0 | 0                             | 0    | 1     | 0 | 0     | 3                | 31 |
| 10:00 AM                              | 0                           | 0    | 0     | 0 | 0                           | 0    | 0     | 0 | 1                             | 1    | 0     | 0 | 0                             | 0    | 0     | 0 | 0     | 2                | 29 |
| 10:05 AM                              | 0                           | 0    | 0     | 0 | 0                           | 0    | 2     | 0 | 0                             | 0    | 0     | 0 | 0                             | 0    | 1     | 0 | 0     | 3                | 32 |
| 10:10 AM                              | 0                           | 0    | 0     | 0 | 0                           | 0    | 0     | 0 | 0                             | 1    | 0     | 0 | 0                             | 0    | 0     | 0 | 0     | 1                | 31 |
| 10:15 AM                              | 0                           | 0    | 0     | 0 | 0                           | 0    | 1     | 0 | 0                             | 0    | 0     | 0 | 0                             | 0    | 0     | 1 | 0     | 2                | 32 |
| 10:20 AM                              | 1                           | 0    | 0     | 0 | 0                           | 0    | 1     | 0 | 0                             | 2    | 0     | 0 | 0                             | 0    | 1     | 0 | 0     | 5                | 35 |
| 10:25 AM                              | 1                           | 0    | 0     | 0 | 0                           | 0    | 0     | 0 | 1                             | 0    | 0     | 0 | 0                             | 0    | 0     | 0 | 0     | 2                | 32 |
| 10:30 AM                              | 0                           | 0    | 0     | 0 | 0                           | 0    | 0     | 0 | 0                             | 0    | 0     | 0 | 0                             | 0    | 0     | 0 | 0     | 0                | 28 |
| 10:35 AM                              | 1                           | 0    | 0     | 0 | 0                           | 0    | 1     | 0 | 1                             | 0    | 0     | 0 | 1                             | 0    | 0     | 0 | 0     | 4                | 31 |
| 10:40 AM                              | 0                           | 0    | 0     | 0 | 0                           | 0    | 2     | 0 | 0                             | 2    | 0     | 0 | 0                             | 2    | 0     | 0 | 0     | 6                | 37 |
| 10:45 AM                              | 0                           | 0    | 0     | 0 | 0                           | 0    | 1     | 0 | 1                             | 0    | 1     | 0 | 0                             | 1    | 0     | 0 | 0     | 4                | 37 |
| 10:50 AM                              | 0                           | 0    | 0     | 0 | 0                           | 0    | 0     | 0 | 0                             | 0    | 0     | 0 | 0                             | 1    | 0     | 0 | 0     | 1                | 33 |
| 10:55 AM                              | 0                           | 0    | 0     | 0 | 0                           | 0    | 0     | 0 | 1                             | 1    | 0     | 0 | 0                             | 1    | 0     | 0 | 0     | 3                | 33 |
| 11:00 AM                              | 0                           | 0    | 0     | 0 | 0                           | 0    | 0     | 0 | 0                             | 1    | 1     | 1 | 0                             | 0    | 2     | 0 | 0     | 4                | 35 |
| 11:05 AM                              | 0                           | 0    | 0     | 0 | 0                           | 0    | 0     | 0 | 0                             | 1    | 0     | 0 | 0                             | 0    | 0     | 0 | 0     | 1                | 33 |
| 11:10 AM                              | 0                           | 0    | 0     | 0 | 0                           | 0    | 0     | 0 | 0                             | 0    | 0     | 0 | 0                             | 0    | 0     | 0 | 0     | 0                | 32 |
| 11:15 AM                              | 0                           | 0    | 0     | 0 | 0                           | 0    | 0     | 0 | 0                             | 1    | 0     | 0 | 0                             | 1    | 0     | 0 | 0     | 2                | 32 |
| 11:20 AM                              | 0                           | 0    | 0     | 0 | 0                           | 1    | 0     | 0 | 1                             | 1    | 1     | 0 | 0                             | 3    | 0     | 0 | 0     | 7                | 34 |
| 11:25 AM                              | 1                           | 0    | 1     | 0 | 0                           | 0    | 0     | 0 | 1                             | 0    | 0     | 0 | 0                             | 2    | 0     | 0 | 0     | 5                | 37 |
| 11:30 AM                              | 0                           | 0    | 0     | 0 | 0                           | 0    | 0     | 0 | 0                             | 1    | 0     | 0 | 0                             | 1    | 0     | 0 | 0     | 2                | 39 |
| 11:35 AM                              | 0                           | 0    | 0     | 0 | 0                           | 0    | 0     | 0 | 0                             | 0    | 0     | 0 | 0                             | 1    | 0     | 0 | 0     | 1                | 36 |
| 11:40 AM                              | 0                           | 0    | 0     | 0 | 0                           | 0    | 0     | 0 | 0                             | 0    | 0     | 0 | 0                             | 0    | 0     | 0 | 0     | 0                | 30 |
| 11:45 AM                              | 0                           | 0    | 0     | 0 | 0                           | 0    | 0     | 0 | 0                             | 0    | 0     | 0 | 0                             | 1    | 0     | 0 | 0     | 1                | 27 |
| 11:50 AM                              | 0                           | 0    | 0     | 0 | 0                           | 0    | 0     | 0 | 1                             | 0    | 1     | 0 | 0                             | 0    | 0     | 0 | 0     | 2                | 28 |
| 11:55 AM                              | 0                           | 0    | 0     | 0 | 0                           | 0    | 0     | 0 | 0                             | 1    | 0     | 0 | 0                             | 0    | 0     | 0 | 0     | 1                | 26 |
| 12:00 PM                              | 0                           | 0    | 0     | 0 | 0                           | 0    | 0     | 0 | 0                             | 0    | 0     | 0 | 0                             | 1    | 0     | 0 | 0     | 1                | 23 |
| 12:05 PM                              | 0                           | 0    | 0     | 0 | 0                           | 0    | 0     | 0 | 1                             | 2    | 0     | 0 | 0                             | 1    | 0     | 0 | 0     | 4                | 26 |
| 12:10 PM                              | 1                           | 0    | 0     | 0 | 0                           | 0    | 2     | 0 | 0                             | 0    | 1     | 0 | 0                             | 1    | 0     | 0 | 0     | 5                | 31 |
| 12:15 PM                              | 0                           | 0    | 0     | 0 | 0                           | 0    | 0     | 0 | 0                             | 1    | 0     | 0 | 0                             | 0    | 0     | 0 | 0     | 1                | 30 |
| 12:20 PM                              | 0                           | 0    | 0     | 0 | 0                           | 0    | 0     | 0 | 0                             | 1    | 0     | 0 | 0                             | 0    | 0     | 0 | 0     | 1                | 24 |
| 12:25 PM                              | 0                           | 0    | 0     | 0 | 0                           | 0    | 0     | 0 | 0                             | 1    | 0     | 0 | 0                             | 1    | 0     | 0 | 0     | 2                | 21 |
| 12:30 PM                              | 1                           | 0    | 0     | 0 | 0                           | 0    | 0     | 0 | 0                             | 0    | 1     | 0 | 0                             | 1    | 0     | 0 | 0     | 3                | 22 |
| 12:35 PM                              | 2                           | 0    | 0     | 0 | 0                           | 0    | 0     | 0 | 0                             | 1    | 0     | 0 | 0                             | 1    | 0     | 0 | 0     | 4                | 25 |
| 12:40 PM                              | 0                           | 0    | 0     | 0 | 0                           | 0    | 0     | 0 | 2                             | 1    | 1     | 0 | 0                             | 1    | 0     | 0 | 0     | 5                | 30 |
| 12:45 PM                              | 1                           | 0    | 0     | 0 | 0                           | 0    | 0     | 0 | 0                             | 0    | 1     | 0 | 0                             | 0    | 0     | 0 | 0     | 2                | 31 |
| 12:50 PM                              | 0                           | 0    | 0     | 0 | 0                           | 0    | 0     | 0 | 0                             | 1    | 0     | 0 | 0                             | 1    | 0     | 0 | 0     | 2                | 31 |
| 12:55 PM                              | 0                           | 0    | 0     | 0 | 0                           | 0    | 0     | 0 | 0                             | 0    | 1     | 0 | 0                             | 0    | 0     | 0 | 0     | 1                | 31 |
| 1:00 PM                               | 2                           | 0    | 0     | 0 | 0                           | 0    | 0     | 0 | 0                             | 0    | 1     | 0 | 0                             | 0    | 0     | 0 | 0     | 3                | 33 |
| 1:05 PM                               | 0                           | 0    | 0     | 0 | 0                           | 0    | 0     | 0 | 0                             | 4    | 0     | 0 | 0                             | 0    | 1     | 0 | 0     | 5                | 34 |
| 1:10 PM                               | 1                           | 0    | 0     | 0 | 0                           | 0    | 0     | 0 | 0                             | 1    | 0     | 0 | 0                             | 2    | 0     | 0 | 0     | 4                | 33 |
| 1:15 PM                               | 0                           | 0    | 0     | 0 | 0                           | 0    | 0     | 0 | 0                             | 2    | 1     | 0 | 0                             | 2    | 0     | 0 | 0     | 5                | 37 |
| 1:20 PM                               | 0                           | 0    | 0     | 0 | 0                           | 0    | 0     | 0 | 0                             | 3    | 0     | 0 | 0                             | 1    | 0     | 0 | 0     | 4                | 40 |
| 1:25 PM                               | 0                           | 0    | 0     | 0 | 0                           | 0    | 1     | 0 | 0                             | 1    | 1     | 0 | 0                             | 1    | 0     | 0 | 0     | 4                | 42 |
| 1:30 PM                               | 1                           | 0    | 0     | 0 | 0                           | 0    | 0     | 0 | 0                             | 0    | 0     | 0 | 0                             | 1    | 0     | 0 | 0     | 2                | 41 |
| 1:35 PM                               | 0                           | 0    | 0     | 0 | 0                           | 0    | 0     | 0 | 0                             | 0    | 0     | 0 | 0                             | 0    | 0     | 0 | 0     | 0                | 37 |
| 1:40 PM                               | 0                           | 0    | 0     | 0 | 0                           | 0    | 0     | 0 | 0                             | 0    | 0     | 0 | 0                             | 1    | 0     | 0 | 0     | 1                | 33 |
| 1:45 PM                               | 1                           | 0    | 0     | 0 | 0                           | 0    | 1     | 0 | 1                             | 0    | 1     | 0 | 0                             | 1    | 0     | 0 | 0     | 5                | 36 |
| 1:50 PM                               | 1                           | 0    | 0     | 0 | 0                           | 0    | 0     | 0 | 0                             | 0    | 0     | 0 | 0                             | 1    | 0     | 0 | 0     | 2                | 36 |
| 1:55 PM                               | 1                           | 0    | 0     | 0 | 0                           | 0    | 0     | 0 | 0                             | 1    | 1     | 0 | 0                             | 1    | 0     | 0 | 0     | 4                | 39 |
| 2:00 PM                               | 0                           | 0    | 0     | 0 | 0                           | 0    | 0     | 0 | 1                             | 3    | 0     | 0 | 0                             | 1    | 0     | 0 | 0     | 5                | 41 |
| 2:05 PM                               | 0                           | 0    | 0     | 0 | 0                           | 0    | 0     | 0 | 0                             | 1    | 0     | 0 | 0                             | 1    | 0     | 0 | 0     | 2                | 38 |
| 2:10 PM                               | 0                           | 0    | 0     | 0 | 0                           | 0    | 0     | 0 | 0                             | 1    | 0     | 0 | 0                             | 0    | 0     | 0 | 0     | 1                | 35 |
| 2:15 PM                               | 0                           | 0    | 0     | 0 | 0                           | 0    | 1     | 0 | 0                             | 0    | 0     | 0 | 0                             | 0    | 0     | 0 | 0     | 1                | 31 |
| 2:20 PM                               | 0                           | 0    | 0     | 0 | 0                           | 0    | 0     | 0 | 0                             | 2    | 1     | 0 | 0                             | 2    | 0     | 0 | 0     | 5                | 32 |
| 2:25 PM                               | 1                           | 0    | 0     | 0 | 0                           | 0    | 0     | 0 | 0                             | 0    | 0     | 0 | 0                             | 0    | 0     | 0 | 0     | 1                | 29 |
| 2:30 PM                               | 0                           | 0    | 0     | 0 | 0                           | 0    | 0     | 0 | 0                             | 2    | 0     | 0 | 0                             | 2    | 0     | 0 | 0     | 4                | 31 |
| 2:35 PM                               | 0                           | 0    | 0     | 0 | 0                           | 0    | 0     | 0 | 0                             | 2    | 2     | 0 | 0                             | 3    | 0     | 0 | 0     | 7                | 38 |
| 2:40 PM                               | 1                           | 0    | 0     | 0 | 0                           | 0    | 0     | 0 | 1                             | 1    | 0     | 0 | 0                             | 1    | 0     | 0 | 0     | 4                | 41 |
| 2:45 PM                               | 0                           | 0    | 0     | 0 | 0                           | 0    | 1     | 0 | 0                             | 1    | 0     | 0 | 0                             | 1    | 0     | 0 | 0     | 3                | 39 |
| 2:50 PM                               | 1                           | 0    | 0     | 0 | 0                           | 0    | 0     | 0 | 0                             | 1    | 1     | 0 | 0                             | 2    | 0     | 0 | 0     | 5                | 42 |
| 2:55 PM                               | 0                           | 0    | 0     | 0 | 0                           | 0    | 0     | 0 | 0                             | 1    | 1     | 0 | 0                             | 1    | 0     | 0 | 0     | 3                | 41 |
| 3:00 PM                               | 0                           | 0    | 0     | 0 | 0                           | 0    | 1     | 0 | 0                             | 0    | 0     | 0 | 0                             | 0    | 0     | 0 | 0     | 1                | 37 |
| 3:05 PM                               | 0                           | 0    | 0     | 0 | 0                           | 0    | 0     | 0 | 0                             | 2    | 0     | 0 | 0                             | 0    | 0     | 0 | 0     | 2                | 37 |
| 3:10 PM                               | 0                           | 0    | 0     | 0 | 0                           | 0    | 0     | 0 | 0                             | 1    | 0     | 0 | 0                             | 1    | 0     | 0 | 0     | 2                | 38 |
| 3:15 PM                               | 2                           | 0    | 0     | 0 | 0                           | 0    | 1     | 0 | 0                             | 0    | 2     | 0 | 0                             | 0    | 0     | 0 | 0     | 5                | 42 |
| 3:20 PM                               | 0                           | 0    | 0     | 0 | 0                           | 0    | 0     | 0 | 0                             | 3    | 0     | 0 | 0                             | 2    | 0     | 0 | 0     | 5                | 42 |
| 3:25 PM                               | 2                           | 0    | 0     | 0 | 0                           | 0    | 0     | 0 | 0                             | 1    | 0     | 0 | 0                             | 3    | 0     | 0 | 0     | 6                | 47 |
| 3:30 PM                               | 0                           | 0    | 0     | 0 | 0                           | 0    | 0     | 0 | 1                             | 4    | 1     | 0 | 0                             | 3    | 0     | 0 | 0     | 9                | 52 |
| 3:35 PM                               | 1                           | 0    | 0     | 0 | 0                           | 0    | 0     | 0 | 0                             | 3    | 2     | 0 | 0                             | 1    | 0     | 0 | 0     | 7                | 52 |
| 3:40 PM                               | 3                           | 1    | 0     | 0 | 0                           | 0    | 1     | 0 | 1                             | 0    | 0     | 0 | 1                             | 0    | 0     | 0 | 0     | 7                | 55 |
| 3:45 PM                               | 0                           | 0    | 0     | 0 | 0                           | 0    | 0     | 0 | 0                             | 1    | 0     | 0 | 0                             | 1    | 0     | 0 | 0     | 2                | 54 |
| 3:50 PM                               | 1                           | 0    | 0     | 0 | 0                           | 0    | 0     | 0 | 1                             | 1    | 0     | 0 | 0                             | 1    | 0     | 0 | 0     | 4                | 53 |
| 3:55 PM                               | 1                           | 0    | 0     | 0 | 0                           | 0    | 0     | 0 | 0                             | 0    | 2     | 0 | 0                             | 1    | 0     | 0 | 0     | 4                | 54 |
| 4:00 PM                               | 0                           | 0    | 0     | 0 | 0                           | 0    | 1     | 0 | 0                             | 2    | 1     | 0 | 0                             | 1    | 0     | 0 | 0     | 5                | 58 |
| 4:05 PM                               | 1                           | 0    | 0     | 0 | 0                           | 0    | 1     | 0 | 0                             | 0    | 0     | 0 | 0                             | 0    | 0     | 0 | 0     | 2                | 58 |
| 4:10 PM                               | 0                           | 0    | 0     | 0 | 0                           | 0    | 0     | 0 | 0                             | 1    | 0     | 0 | 0                             | 2    | 0     | 0 | 0     | 3                | 59 |
| 4:15 PM                               | 0                           | 0    | 0     | 0 | 0                           | 0    | 1     | 0 | 0                             | 1    | 1     | 0 | 0                             | 1    | 0     | 0 | 0     | 4                | 58 |
| 4:20 PM                               | 0                           | 0    | 0     | 0 | 0                           | 0    | 0     | 0 | 1                             | 1    | 0     | 0 | 0                             | 3    | 0     | 0 | 0     | 5                | 58 |
| 4:25 PM                               | 0                           | 0    | 0     | 0 | 0                           | 0    | 0     | 0 | 0                             | 2    | 0     | 0 | 0                             | 1    | 0     | 0 | 0     | 3                | 55 |

**Attachment B**

| 5-Min Count Period Beginning At | Magnolia Dr (Northbound) |      |       |   | Magnolia Dr (Southbound) |      |       |   | Blue Spruce Dr (Eastbound) |      |       |   | Blue Spruce Dr (Westbound) |      |       |   | Total | Hourly Totals |
|---------------------------------|--------------------------|------|-------|---|--------------------------|------|-------|---|----------------------------|------|-------|---|----------------------------|------|-------|---|-------|---------------|
|                                 | Left                     | Thru | Right | U | Left                     | Thru | Right | U | Left                       | Thru | Right | U | Left                       | Thru | Right | U |       |               |
| 4:30 PM                         | 0                        | 0    | 0     | 0 | 0                        | 0    | 1     | 0 | 0                          | 0    | 1     | 0 | 0                          | 2    | 0     | 0 | 4     | 50            |
| 4:35 PM                         | 0                        | 0    | 0     | 0 | 0                        | 0    | 0     | 0 | 0                          | 2    | 0     | 0 | 0                          | 1    | 0     | 0 | 3     | 46            |
| 4:40 PM                         | 0                        | 0    | 0     | 0 | 0                        | 0    | 0     | 0 | 0                          | 1    | 0     | 0 | 0                          | 1    | 0     | 0 | 2     | 41            |
| 4:45 PM                         | 2                        | 0    | 0     | 0 | 0                        | 0    | 0     | 0 | 1                          | 0    | 0     | 0 | 0                          | 1    | 0     | 0 | 4     | 43            |
| 4:50 PM                         | 0                        | 0    | 0     | 0 | 0                        | 0    | 0     | 0 | 0                          | 2    | 0     | 0 | 0                          | 0    | 0     | 0 | 2     | 41            |
| 4:55 PM                         | 0                        | 0    | 0     | 0 | 0                        | 0    | 0     | 0 | 0                          | 1    | 0     | 0 | 0                          | 0    | 0     | 0 | 1     | 38            |
| 5:00 PM                         | 1                        | 0    | 0     | 0 | 0                        | 0    | 0     | 0 | 1                          | 1    | 1     | 0 | 0                          | 0    | 0     | 0 | 4     | 37            |
| 5:05 PM                         | 0                        | 0    | 0     | 0 | 0                        | 1    | 0     | 0 | 0                          | 0    | 0     | 0 | 0                          | 0    | 0     | 0 | 1     | 36            |
| 5:10 PM                         | 0                        | 0    | 1     | 0 | 0                        | 0    | 1     | 0 | 1                          | 0    | 1     | 0 | 0                          | 0    | 0     | 0 | 4     | 37            |
| 5:15 PM                         | 1                        | 0    | 0     | 0 | 0                        | 0    | 0     | 0 | 0                          | 0    | 1     | 0 | 0                          | 2    | 0     | 0 | 4     | 37            |
| 5:20 PM                         | 0                        | 0    | 0     | 0 | 0                        | 0    | 0     | 0 | 1                          | 3    | 2     | 0 | 0                          | 0    | 0     | 0 | 6     | 38            |
| 5:25 PM                         | 0                        | 0    | 1     | 0 | 0                        | 0    | 1     | 0 | 0                          | 0    | 2     | 0 | 0                          | 0    | 0     | 0 | 4     | 39            |
| 5:30 PM                         | 2                        | 0    | 0     | 0 | 0                        | 0    | 0     | 0 | 0                          | 0    | 0     | 0 | 0                          | 0    | 0     | 0 | 2     | 37            |
| 5:35 PM                         | 0                        | 0    | 0     | 0 | 0                        | 0    | 0     | 0 | 0                          | 1    | 0     | 0 | 0                          | 1    | 0     | 0 | 2     | 36            |
| 5:40 PM                         | 0                        | 0    | 0     | 0 | 0                        | 0    | 0     | 0 | 0                          | 1    | 0     | 0 | 0                          | 1    | 0     | 0 | 2     | 36            |
| 5:45 PM                         | 0                        | 0    | 0     | 0 | 0                        | 0    | 0     | 0 | 0                          | 0    | 1     | 0 | 0                          | 0    | 0     | 0 | 1     | 33            |
| 5:50 PM                         | 0                        | 0    | 0     | 0 | 0                        | 0    | 0     | 0 | 1                          | 0    | 1     | 0 | 0                          | 0    | 0     | 0 | 2     | 33            |
| 5:55 PM                         | 0                        | 0    | 0     | 0 | 0                        | 0    | 1     | 0 | 0                          | 1    | 0     | 0 | 0                          | 1    | 0     | 0 | 3     | 35            |
| 6:00 PM                         | 1                        | 0    | 0     | 0 | 0                        | 0    | 0     | 0 | 0                          | 2    | 0     | 0 | 0                          | 0    | 0     | 0 | 3     | 34            |
| 6:05 PM                         | 0                        | 0    | 0     | 0 | 0                        | 0    | 0     | 0 | 0                          | 1    | 1     | 0 | 0                          | 2    | 0     | 0 | 4     | 37            |
| 6:10 PM                         | 0                        | 0    | 0     | 0 | 0                        | 0    | 0     | 0 | 0                          | 2    | 0     | 0 | 1                          | 1    | 0     | 0 | 4     | 37            |
| 6:15 PM                         | 1                        | 0    | 0     | 0 | 0                        | 0    | 0     | 0 | 0                          | 2    | 0     | 0 | 0                          | 0    | 0     | 0 | 3     | 36            |
| 6:20 PM                         | 0                        | 0    | 0     | 0 | 0                        | 0    | 0     | 0 | 0                          | 1    | 0     | 0 | 0                          | 0    | 0     | 0 | 1     | 31            |
| 6:25 PM                         | 0                        | 0    | 0     | 0 | 0                        | 0    | 0     | 0 | 0                          | 1    | 1     | 0 | 0                          | 0    | 0     | 0 | 2     | 29            |
| 6:30 PM                         | 0                        | 0    | 0     | 0 | 0                        | 0    | 1     | 0 | 0                          | 0    | 0     | 0 | 0                          | 0    | 0     | 0 | 1     | 28            |
| 6:35 PM                         | 1                        | 0    | 0     | 0 | 0                        | 0    | 0     | 0 | 0                          | 1    | 3     | 0 | 0                          | 0    | 0     | 0 | 5     | 31            |
| 6:40 PM                         | 1                        | 0    | 0     | 0 | 0                        | 0    | 0     | 0 | 0                          | 2    | 0     | 0 | 0                          | 2    | 0     | 0 | 5     | 34            |
| 6:45 PM                         | 0                        | 0    | 0     | 0 | 0                        | 0    | 0     | 0 | 0                          | 0    | 1     | 0 | 0                          | 1    | 0     | 0 | 2     | 35            |
| 6:50 PM                         | 2                        | 0    | 0     | 0 | 0                        | 0    | 0     | 0 | 0                          | 1    | 0     | 0 | 0                          | 1    | 0     | 0 | 4     | 37            |
| 6:55 PM                         | 0                        | 0    | 0     | 0 | 0                        | 0    | 0     | 0 | 0                          | 0    | 1     | 0 | 0                          | 0    | 0     | 0 | 1     | 35            |
| 7:00 PM                         | 1                        | 0    | 0     | 0 | 0                        | 0    | 0     | 0 | 2                          | 0    | 0     | 0 | 0                          | 0    | 0     | 0 | 3     | 35            |
| 7:05 PM                         | 0                        | 0    | 0     | 0 | 0                        | 0    | 0     | 0 | 0                          | 0    | 0     | 0 | 0                          | 0    | 0     | 0 | 0     | 31            |
| 7:10 PM                         | 1                        | 0    | 0     | 0 | 0                        | 0    | 0     | 0 | 0                          | 1    | 1     | 0 | 0                          | 1    | 0     | 0 | 4     | 31            |
| 7:15 PM                         | 0                        | 0    | 0     | 0 | 0                        | 0    | 0     | 0 | 2                          | 0    | 1     | 0 | 0                          | 0    | 0     | 0 | 3     | 31            |
| 7:20 PM                         | 0                        | 0    | 0     | 0 | 0                        | 0    | 0     | 0 | 1                          | 0    | 1     | 0 | 0                          | 0    | 0     | 0 | 2     | 32            |
| 7:25 PM                         | 0                        | 0    | 0     | 0 | 0                        | 0    | 0     | 0 | 0                          | 2    | 1     | 0 | 0                          | 1    | 0     | 0 | 4     | 34            |
| 7:30 PM                         | 0                        | 0    | 0     | 0 | 0                        | 0    | 0     | 0 | 0                          | 0    | 0     | 0 | 0                          | 0    | 0     | 0 | 0     | 33            |
| 7:35 PM                         | 0                        | 0    | 0     | 0 | 0                        | 0    | 1     | 0 | 1                          | 0    | 2     | 0 | 0                          | 2    | 0     | 0 | 6     | 34            |
| 7:40 PM                         | 0                        | 0    | 0     | 0 | 0                        | 0    | 0     | 0 | 0                          | 1    | 0     | 0 | 0                          | 0    | 0     | 0 | 1     | 30            |
| 7:45 PM                         | 0                        | 0    | 0     | 0 | 0                        | 0    | 0     | 0 | 0                          | 0    | 0     | 0 | 0                          | 0    | 0     | 0 | 0     | 28            |
| 7:50 PM                         | 1                        | 0    | 0     | 0 | 0                        | 0    | 0     | 0 | 0                          | 1    | 1     | 0 | 0                          | 0    | 0     | 0 | 3     | 27            |
| 7:55 PM                         | 1                        | 0    | 0     | 0 | 0                        | 0    | 2     | 0 | 0                          | 1    | 0     | 0 | 0                          | 0    | 0     | 0 | 4     | 30            |
| 8:00 PM                         | 0                        | 0    | 0     | 0 | 0                        | 0    | 0     | 0 | 0                          | 0    | 0     | 0 | 0                          | 0    | 0     | 0 | 0     | 27            |
| 8:05 PM                         | 0                        | 0    | 0     | 0 | 0                        | 0    | 0     | 0 | 0                          | 1    | 0     | 0 | 0                          | 1    | 0     | 0 | 2     | 29            |
| 8:10 PM                         | 0                        | 0    | 0     | 0 | 0                        | 0    | 0     | 0 | 0                          | 0    | 3     | 0 | 0                          | 1    | 0     | 0 | 4     | 29            |
| 8:15 PM                         | 0                        | 0    | 0     | 0 | 0                        | 0    | 0     | 0 | 0                          | 1    | 0     | 0 | 0                          | 0    | 0     | 0 | 1     | 27            |
| 8:20 PM                         | 0                        | 0    | 0     | 0 | 0                        | 0    | 0     | 0 | 0                          | 0    | 1     | 0 | 0                          | 1    | 0     | 0 | 2     | 27            |
| 8:25 PM                         | 0                        | 0    | 0     | 0 | 0                        | 0    | 0     | 0 | 0                          | 0    | 0     | 0 | 0                          | 0    | 0     | 0 | 0     | 23            |
| 8:30 PM                         | 0                        | 0    | 0     | 0 | 0                        | 0    | 0     | 0 | 0                          | 1    | 0     | 0 | 1                          | 1    | 0     | 0 | 3     | 26            |
| 8:35 PM                         | 0                        | 0    | 0     | 0 | 0                        | 0    | 0     | 0 | 0                          | 0    | 1     | 0 | 0                          | 0    | 0     | 0 | 1     | 21            |
| 8:40 PM                         | 1                        | 0    | 0     | 0 | 0                        | 0    | 0     | 0 | 0                          | 1    | 1     | 0 | 0                          | 0    | 0     | 0 | 3     | 23            |
| 8:45 PM                         | 0                        | 0    | 0     | 0 | 0                        | 0    | 0     | 0 | 0                          | 0    | 0     | 0 | 0                          | 0    | 0     | 0 | 0     | 23            |
| 8:50 PM                         | 0                        | 0    | 0     | 0 | 0                        | 0    | 0     | 0 | 0                          | 0    | 1     | 0 | 0                          | 0    | 0     | 0 | 1     | 21            |
| 8:55 PM                         | 1                        | 0    | 0     | 0 | 0                        | 0    | 0     | 0 | 1                          | 0    | 0     | 0 | 0                          | 0    | 0     | 0 | 2     | 19            |
| 9:00 PM                         | 1                        | 0    | 0     | 0 | 0                        | 0    | 0     | 0 | 0                          | 3    | 0     | 0 | 0                          | 0    | 0     | 0 | 4     | 23            |
| 9:05 PM                         | 0                        | 0    | 0     | 0 | 0                        | 0    | 0     | 0 | 0                          | 0    | 0     | 0 | 0                          | 0    | 0     | 0 | 0     | 21            |
| 9:10 PM                         | 0                        | 0    | 0     | 0 | 0                        | 0    | 0     | 0 | 0                          | 1    | 1     | 0 | 0                          | 1    | 0     | 0 | 3     | 20            |
| 9:15 PM                         | 0                        | 0    | 0     | 0 | 0                        | 0    | 0     | 0 | 1                          | 0    | 1     | 0 | 0                          | 0    | 0     | 0 | 2     | 21            |
| 9:20 PM                         | 0                        | 0    | 0     | 0 | 0                        | 0    | 0     | 0 | 0                          | 0    | 0     | 0 | 0                          | 0    | 0     | 0 | 0     | 19            |
| 9:25 PM                         | 0                        | 0    | 0     | 0 | 0                        | 0    | 0     | 0 | 0                          | 1    | 0     | 0 | 0                          | 0    | 0     | 0 | 1     | 20            |
| 9:30 PM                         | 0                        | 0    | 0     | 0 | 0                        | 0    | 0     | 0 | 0                          | 0    | 0     | 0 | 0                          | 0    | 0     | 0 | 0     | 17            |
| 9:35 PM                         | 0                        | 0    | 0     | 0 | 0                        | 0    | 0     | 0 | 0                          | 0    | 0     | 0 | 0                          | 0    | 0     | 0 | 0     | 16            |
| 9:40 PM                         | 0                        | 0    | 0     | 0 | 0                        | 0    | 0     | 0 | 0                          | 2    | 0     | 0 | 0                          | 1    | 0     | 0 | 3     | 16            |
| 9:45 PM                         | 0                        | 0    | 0     | 0 | 0                        | 0    | 0     | 0 | 0                          | 0    | 0     | 0 | 0                          | 1    | 0     | 0 | 1     | 17            |
| 9:50 PM                         | 0                        | 0    | 0     | 0 | 0                        | 0    | 0     | 0 | 0                          | 0    | 1     | 0 | 0                          | 0    | 0     | 0 | 1     | 17            |
| 9:55 PM                         | 0                        | 0    | 0     | 0 | 0                        | 0    | 0     | 0 | 0                          | 0    | 0     | 0 | 0                          | 0    | 0     | 0 | 0     | 15            |
| Peak 15-Min Flowrates           | Northbound               |      |       |   | Southbound               |      |       |   | Eastbound                  |      |       |   | Westbound                  |      |       |   | Total |               |
|                                 | Left                     | Thru | Right | U | Left                     | Thru | Right | U | Left                       | Thru | Right | U | Left                       | Thru | Right | U |       |               |
| All Vehicles                    | 16                       | 4    | 0     | 0 | 0                        | 0    | 4     | 0 | 8                          | 28   | 12    | 0 | 4                          | 16   | 0     | 0 | 92    |               |
| Heavy Trucks                    | 0                        | 0    | 0     |   | 0                        | 0    | 0     |   | 0                          | 0    | 0     |   | 0                          | 0    | 0     |   | 0     |               |
| Buses                           |                          |      |       |   |                          |      |       |   |                            |      |       |   |                            |      |       |   |       |               |
| Pedestrians                     |                          | 4    |       |   |                          | 4    |       |   |                            | 0    |       |   |                            | 0    |       |   | 8     |               |
| Bicycles                        | 4                        | 0    | 0     |   | 0                        | 0    | 0     |   | 0                          | 0    | 4     |   | 0                          | 0    | 0     |   | 8     |               |
| Scoters                         |                          |      |       |   |                          |      |       |   |                            |      |       |   |                            |      |       |   |       |               |
| <i>Comments:</i>                |                          |      |       |   |                          |      |       |   |                            |      |       |   |                            |      |       |   |       |               |

Report generated on 4/25/2025 4:03 PM

SOURCE: Quality Counts, LLC (<http://www.qualitycounts.net>) 1-877-580-2212

LOCATION: Shively Rd -- Ranunculus St  
 CITY/STATE: Ladera Ranch, CA

QC JOB #: 16966463  
 DATE: Wed, Apr 16 2025

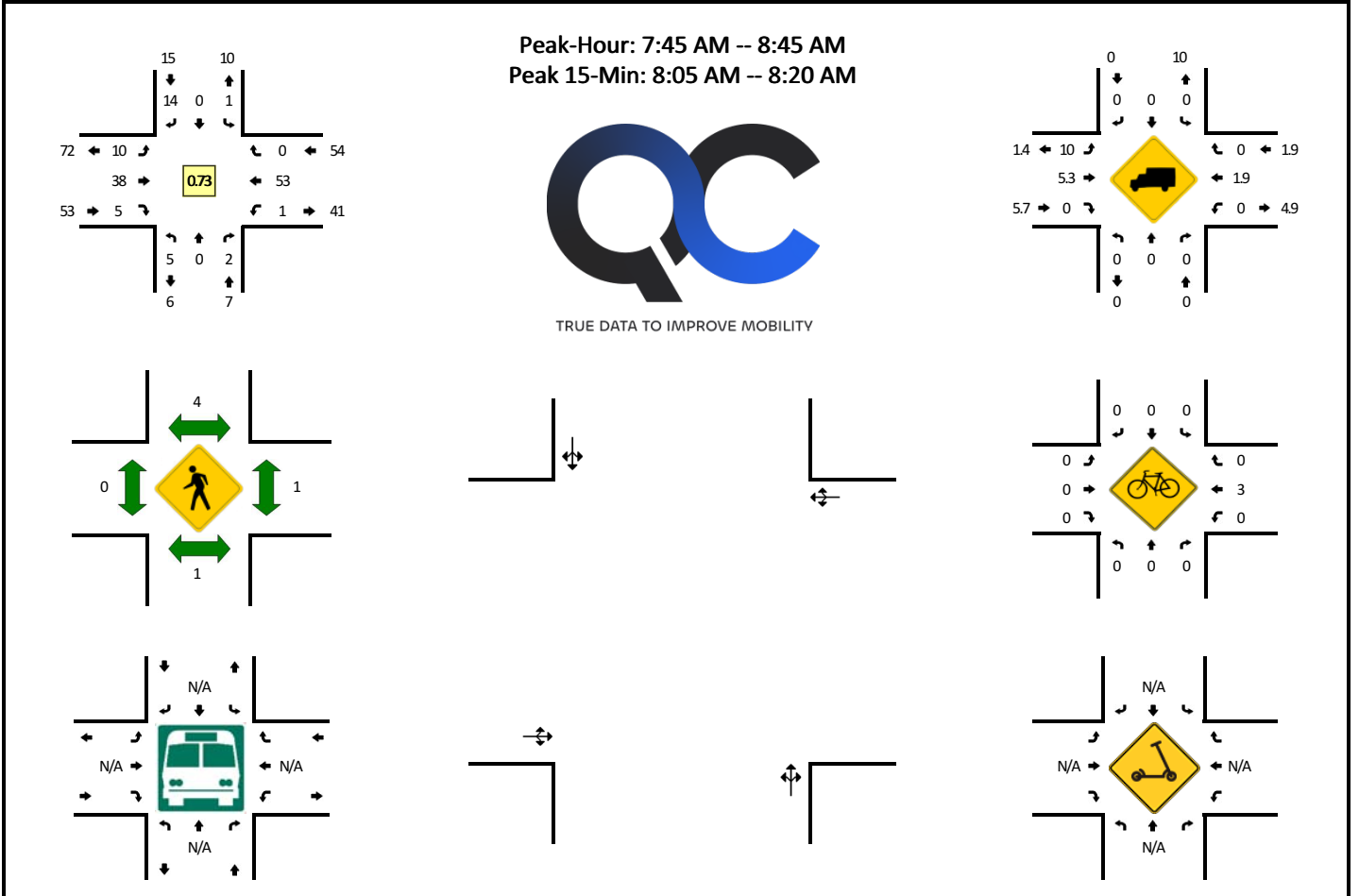

| 5-Min Count Period Beginning At | Shively Rd (Northbound) |      |       |   | Shively Rd (Southbound) |      |       |   | Ranunculus St (Eastbound) |      |       |   | Ranunculus St (Westbound) |      |       |   | Total | Hourly Totals |    |     |
|---------------------------------|-------------------------|------|-------|---|-------------------------|------|-------|---|---------------------------|------|-------|---|---------------------------|------|-------|---|-------|---------------|----|-----|
|                                 | Left                    | Thru | Right | U | Left                    | Thru | Right | U | Left                      | Thru | Right | U | Left                      | Thru | Right | U |       |               |    |     |
| 6:00 AM                         | 0                       | 0    | 1     | 0 | 0                       | 0    | 0     | 0 | 0                         | 0    | 0     | 0 | 0                         | 1    | 0     | 0 | 0     | 2             |    |     |
| 6:05 AM                         | 0                       | 0    | 0     | 0 | 0                       | 0    | 2     | 0 | 0                         | 1    | 2     | 0 | 0                         | 0    | 1     | 1 | 0     | 0             | 7  |     |
| 6:10 AM                         | 0                       | 0    | 0     | 0 | 0                       | 0    | 0     | 0 | 0                         | 0    | 0     | 0 | 0                         | 0    | 2     | 0 | 0     | 0             | 2  |     |
| 6:15 AM                         | 1                       | 0    | 0     | 0 | 0                       | 0    | 0     | 0 | 0                         | 0    | 0     | 0 | 0                         | 0    | 1     | 0 | 0     | 0             | 2  |     |
| 6:20 AM                         | 0                       | 0    | 0     | 0 | 0                       | 0    | 0     | 0 | 0                         | 0    | 0     | 0 | 0                         | 0    | 0     | 0 | 0     | 0             | 0  |     |
| 6:25 AM                         | 0                       | 0    | 0     | 0 | 0                       | 0    | 1     | 0 | 0                         | 0    | 0     | 0 | 0                         | 0    | 0     | 0 | 0     | 0             | 1  |     |
| 6:30 AM                         | 0                       | 0    | 0     | 0 | 0                       | 0    | 0     | 0 | 0                         | 0    | 0     | 0 | 0                         | 0    | 0     | 0 | 0     | 0             | 0  |     |
| 6:35 AM                         | 0                       | 0    | 0     | 0 | 0                       | 0    | 0     | 0 | 0                         | 0    | 0     | 0 | 0                         | 0    | 2     | 0 | 0     | 0             | 2  |     |
| 6:40 AM                         | 0                       | 0    | 0     | 0 | 0                       | 0    | 0     | 0 | 0                         | 0    | 0     | 0 | 0                         | 0    | 0     | 0 | 0     | 0             | 0  |     |
| 6:45 AM                         | 0                       | 0    | 0     | 0 | 1                       | 0    | 0     | 0 | 0                         | 0    | 1     | 0 | 0                         | 0    | 2     | 0 | 0     | 0             | 4  |     |
| 6:50 AM                         | 0                       | 0    | 0     | 0 | 0                       | 0    | 1     | 0 | 0                         | 0    | 1     | 0 | 0                         | 0    | 3     | 0 | 0     | 0             | 5  |     |
| 6:55 AM                         | 0                       | 0    | 0     | 0 | 0                       | 0    | 1     | 0 | 0                         | 0    | 1     | 0 | 0                         | 0    | 2     | 0 | 0     | 0             | 4  | 29  |
| 7:00 AM                         | 0                       | 0    | 0     | 0 | 0                       | 0    | 1     | 0 | 0                         | 0    | 0     | 0 | 0                         | 0    | 3     | 0 | 0     | 0             | 4  | 31  |
| 7:05 AM                         | 0                       | 0    | 0     | 0 | 0                       | 0    | 0     | 0 | 0                         | 0    | 0     | 0 | 0                         | 0    | 2     | 0 | 0     | 0             | 2  | 26  |
| 7:10 AM                         | 1                       | 0    | 0     | 0 | 0                       | 0    | 0     | 0 | 0                         | 0    | 0     | 1 | 0                         | 0    | 4     | 0 | 0     | 0             | 6  | 30  |
| 7:15 AM                         | 1                       | 0    | 0     | 0 | 0                       | 0    | 0     | 0 | 0                         | 0    | 0     | 0 | 0                         | 0    | 5     | 0 | 0     | 0             | 6  | 34  |
| 7:20 AM                         | 2                       | 0    | 0     | 0 | 0                       | 0    | 0     | 0 | 0                         | 2    | 1     | 0 | 0                         | 0    | 2     | 0 | 0     | 0             | 7  | 41  |
| 7:25 AM                         | 0                       | 0    | 0     | 0 | 0                       | 0    | 3     | 0 | 0                         | 0    | 3     | 0 | 0                         | 0    | 1     | 0 | 0     | 0             | 7  | 47  |
| 7:30 AM                         | 1                       | 0    | 0     | 0 | 0                       | 0    | 0     | 0 | 0                         | 1    | 0     | 0 | 0                         | 0    | 2     | 0 | 0     | 0             | 4  | 51  |
| 7:35 AM                         | 1                       | 0    | 0     | 0 | 0                       | 0    | 1     | 0 | 0                         | 0    | 2     | 0 | 0                         | 0    | 4     | 0 | 0     | 0             | 8  | 57  |
| 7:40 AM                         | 0                       | 0    | 0     | 0 | 0                       | 0    | 0     | 0 | 0                         | 0    | 1     | 0 | 0                         | 0    | 3     | 0 | 0     | 0             | 4  | 61  |
| 7:45 AM                         | 1                       | 0    | 0     | 0 | 0                       | 0    | 0     | 0 | 0                         | 0    | 2     | 0 | 0                         | 0    | 7     | 0 | 0     | 0             | 10 | 67  |
| 7:50 AM                         | 0                       | 0    | 0     | 0 | 0                       | 0    | 4     | 0 | 0                         | 0    | 3     | 1 | 0                         | 0    | 5     | 0 | 0     | 0             | 13 | 75  |
| 7:55 AM                         | 0                       | 0    | 0     | 0 | 0                       | 0    | 2     | 0 | 0                         | 1    | 1     | 0 | 0                         | 0    | 6     | 0 | 0     | 0             | 10 | 81  |
| 8:00 AM                         | 0                       | 0    | 0     | 0 | 0                       | 0    | 1     | 0 | 0                         | 0    | 2     | 0 | 0                         | 0    | 4     | 0 | 0     | 0             | 7  | 84  |
| 8:05 AM                         | 1                       | 0    | 2     | 0 | 0                       | 0    | 1     | 0 | 0                         | 1    | 10    | 1 | 0                         | 1    | 6     | 0 | 0     | 0             | 23 | 105 |
| 8:10 AM                         | 1                       | 0    | 0     | 0 | 0                       | 0    | 2     | 0 | 0                         | 2    | 0     | 0 | 0                         | 0    | 6     | 0 | 0     | 0             | 11 | 110 |
| 8:15 AM                         | 0                       | 0    | 0     | 0 | 0                       | 0    | 2     | 0 | 0                         | 1    | 3     | 1 | 0                         | 0    | 3     | 0 | 0     | 0             | 10 | 114 |
| 8:20 AM                         | 0                       | 0    | 0     | 0 | 0                       | 0    | 1     | 0 | 0                         | 2    | 4     | 0 | 0                         | 0    | 3     | 0 | 0     | 0             | 10 | 117 |
| 8:25 AM                         | 1                       | 0    | 0     | 0 | 0                       | 0    | 0     | 0 | 0                         | 1    | 5     | 0 | 0                         | 0    | 2     | 0 | 0     | 0             | 9  | 119 |
| 8:30 AM                         | 0                       | 0    | 0     | 0 | 0                       | 0    | 0     | 0 | 0                         | 1    | 4     | 0 | 0                         | 0    | 4     | 0 | 0     | 0             | 9  | 124 |
| 8:35 AM                         | 1                       | 0    | 0     | 0 | 0                       | 0    | 0     | 0 | 0                         | 0    | 3     | 0 | 0                         | 0    | 3     | 0 | 0     | 0             | 7  | 123 |
| 8:40 AM                         | 0                       | 0    | 0     | 0 | 1                       | 0    | 1     | 0 | 0                         | 1    | 1     | 2 | 0                         | 0    | 4     | 0 | 0     | 0             | 10 | 129 |
| 8:45 AM                         | 0                       | 0    | 0     | 0 | 0                       | 1    | 0     | 0 | 0                         | 0    | 3     | 1 | 0                         | 0    | 5     | 0 | 0     | 0             | 10 | 129 |
| 8:50 AM                         | 0                       | 0    | 1     | 0 | 0                       | 0    | 3     | 0 | 0                         | 0    | 2     | 0 | 0                         | 1    | 3     | 0 | 0     | 0             | 10 | 126 |
| 8:55 AM                         | 0                       | 0    | 0     | 0 | 0                       | 0    | 2     | 0 | 0                         | 0    | 1     | 0 | 0                         | 0    | 2     | 0 | 0     | 0             | 5  | 121 |
| 9:00 AM                         | 0                       | 0    | 0     | 0 | 0                       | 0    | 1     | 0 | 0                         | 1    | 2     | 0 | 0                         | 0    | 3     | 0 | 0     | 0             | 7  | 121 |
| 9:05 AM                         | 0                       | 0    | 0     | 0 | 0                       | 0    | 1     | 0 | 0                         | 0    | 2     | 0 | 0                         | 0    | 2     | 0 | 0     | 0             | 5  | 103 |

**Attachment B**

| 5-Min Count Period Beginning At | Shively Rd (Northbound) |      |       |   | Shively Rd (Southbound) |      |       |   | Ranunculus St (Eastbound) |      |       |   | Ranunculus St (Westbound) |      |       |   | Total | Hourly Totals |
|---------------------------------|-------------------------|------|-------|---|-------------------------|------|-------|---|---------------------------|------|-------|---|---------------------------|------|-------|---|-------|---------------|
|                                 | Left                    | Thru | Right | U | Left                    | Thru | Right | U | Left                      | Thru | Right | U | Left                      | Thru | Right | U |       |               |
| 9:10 AM                         | 0                       | 0    | 0     | 0 | 0                       | 0    | 0     | 0 | 0                         | 0    | 0     | 0 | 0                         | 1    | 0     | 0 | 1     | 93            |
| 9:15 AM                         | 1                       | 0    | 0     | 0 | 0                       | 0    | 1     | 0 | 0                         | 1    | 0     | 0 | 1                         | 1    | 0     | 0 | 5     | 88            |
| 9:20 AM                         | 1                       | 0    | 0     | 0 | 0                       | 0    | 0     | 0 | 1                         | 0    | 1     | 0 | 0                         | 3    | 0     | 0 | 6     | 84            |
| 9:25 AM                         | 0                       | 1    | 0     | 0 | 0                       | 0    | 0     | 0 | 0                         | 2    | 0     | 0 | 0                         | 1    | 0     | 0 | 4     | 79            |
| 9:30 AM                         | 0                       | 0    | 0     | 0 | 0                       | 0    | 1     | 0 | 0                         | 0    | 0     | 0 | 0                         | 1    | 0     | 0 | 2     | 72            |
| 9:35 AM                         | 1                       | 0    | 0     | 0 | 0                       | 0    | 1     | 0 | 0                         | 2    | 1     | 0 | 0                         | 0    | 0     | 0 | 5     | 70            |
| 9:40 AM                         | 0                       | 0    | 0     | 0 | 0                       | 0    | 0     | 0 | 1                         | 0    | 0     | 1 | 0                         | 0    | 1     | 0 | 3     | 63            |
| 9:45 AM                         | 0                       | 0    | 0     | 0 | 0                       | 0    | 1     | 0 | 1                         | 0    | 0     | 0 | 0                         | 2    | 0     | 0 | 4     | 57            |
| 9:50 AM                         | 0                       | 0    | 0     | 0 | 0                       | 0    | 2     | 0 | 0                         | 0    | 0     | 0 | 0                         | 0    | 0     | 0 | 2     | 49            |
| 9:55 AM                         | 0                       | 0    | 0     | 0 | 0                       | 0    | 1     | 0 | 1                         | 1    | 0     | 0 | 0                         | 0    | 0     | 0 | 3     | 47            |
| 10:00 AM                        | 0                       | 0    | 0     | 0 | 0                       | 0    | 1     | 0 | 0                         | 3    | 0     | 0 | 0                         | 0    | 0     | 0 | 4     | 44            |
| 10:05 AM                        | 0                       | 0    | 0     | 0 | 0                       | 0    | 1     | 0 | 1                         | 1    | 0     | 0 | 0                         | 2    | 0     | 0 | 5     | 44            |
| 10:10 AM                        | 0                       | 0    | 0     | 0 | 0                       | 0    | 0     | 0 | 0                         | 2    | 0     | 0 | 0                         | 2    | 0     | 0 | 4     | 47            |
| 10:15 AM                        | 0                       | 0    | 0     | 0 | 0                       | 0    | 1     | 0 | 0                         | 1    | 0     | 0 | 0                         | 0    | 0     | 0 | 2     | 44            |
| 10:20 AM                        | 1                       | 0    | 0     | 0 | 0                       | 0    | 0     | 0 | 0                         | 0    | 0     | 0 | 0                         | 3    | 1     | 0 | 5     | 43            |
| 10:25 AM                        | 0                       | 0    | 0     | 0 | 0                       | 0    | 1     | 0 | 1                         | 0    | 0     | 0 | 0                         | 3    | 0     | 0 | 5     | 44            |
| 10:30 AM                        | 2                       | 0    | 0     | 0 | 0                       | 0    | 0     | 0 | 0                         | 2    | 0     | 0 | 0                         | 2    | 0     | 0 | 6     | 48            |
| 10:35 AM                        | 0                       | 0    | 0     | 0 | 0                       | 0    | 0     | 0 | 1                         | 5    | 0     | 0 | 0                         | 1    | 0     | 0 | 7     | 50            |
| 10:40 AM                        | 0                       | 0    | 0     | 0 | 0                       | 0    | 0     | 0 | 0                         | 0    | 0     | 0 | 0                         | 2    | 0     | 0 | 2     | 49            |
| 10:45 AM                        | 0                       | 0    | 0     | 0 | 0                       | 0    | 0     | 0 | 1                         | 0    | 1     | 0 | 0                         | 2    | 0     | 0 | 4     | 49            |
| 10:50 AM                        | 1                       | 0    | 0     | 0 | 0                       | 0    | 0     | 0 | 1                         | 3    | 1     | 0 | 0                         | 0    | 0     | 0 | 6     | 53            |
| 10:55 AM                        | 1                       | 0    | 0     | 0 | 0                       | 0    | 2     | 0 | 0                         | 2    | 0     | 0 | 0                         | 2    | 0     | 0 | 7     | 57            |
| 11:00 AM                        | 0                       | 0    | 0     | 0 | 0                       | 0    | 0     | 0 | 1                         | 3    | 0     | 0 | 0                         | 1    | 0     | 0 | 5     | 58            |
| 11:05 AM                        | 0                       | 0    | 0     | 0 | 0                       | 0    | 0     | 0 | 1                         | 0    | 0     | 0 | 0                         | 0    | 0     | 0 | 1     | 54            |
| 11:10 AM                        | 1                       | 0    | 0     | 0 | 0                       | 0    | 0     | 0 | 0                         | 0    | 1     | 0 | 0                         | 0    | 0     | 0 | 2     | 52            |
| 11:15 AM                        | 0                       | 0    | 0     | 0 | 0                       | 0    | 1     | 0 | 0                         | 1    | 0     | 0 | 0                         | 1    | 0     | 0 | 3     | 53            |
| 11:20 AM                        | 0                       | 0    | 0     | 0 | 0                       | 0    | 0     | 0 | 1                         | 0    | 0     | 0 | 0                         | 0    | 0     | 0 | 1     | 49            |
| 11:25 AM                        | 0                       | 0    | 0     | 0 | 1                       | 0    | 0     | 0 | 1                         | 1    | 0     | 0 | 0                         | 2    | 0     | 0 | 5     | 49            |
| 11:30 AM                        | 2                       | 0    | 0     | 0 | 0                       | 0    | 0     | 0 | 0                         | 2    | 0     | 0 | 0                         | 3    | 0     | 0 | 7     | 50            |
| 11:35 AM                        | 0                       | 0    | 0     | 0 | 0                       | 0    | 0     | 0 | 0                         | 0    | 3     | 0 | 0                         | 4    | 0     | 0 | 7     | 50            |
| 11:40 AM                        | 1                       | 0    | 0     | 0 | 0                       | 0    | 0     | 0 | 0                         | 1    | 0     | 0 | 0                         | 1    | 0     | 0 | 3     | 51            |
| 11:45 AM                        | 0                       | 1    | 0     | 0 | 0                       | 0    | 2     | 0 | 1                         | 2    | 1     | 0 | 0                         | 2    | 0     | 0 | 9     | 56            |
| 11:50 AM                        | 0                       | 0    | 0     | 0 | 0                       | 0    | 0     | 0 | 0                         | 0    | 0     | 0 | 0                         | 1    | 0     | 0 | 1     | 51            |
| 11:55 AM                        | 0                       | 0    | 0     | 0 | 1                       | 0    | 2     | 0 | 0                         | 1    | 1     | 0 | 0                         | 0    | 0     | 0 | 5     | 49            |
| 12:00 PM                        | 0                       | 0    | 1     | 0 | 0                       | 0    | 0     | 0 | 2                         | 2    | 1     | 0 | 0                         | 2    | 0     | 0 | 8     | 52            |
| 12:05 PM                        | 1                       | 0    | 0     | 0 | 0                       | 0    | 0     | 0 | 0                         | 5    | 1     | 0 | 0                         | 3    | 0     | 0 | 10    | 61            |
| 12:10 PM                        | 0                       | 0    | 0     | 0 | 0                       | 0    | 0     | 0 | 1                         | 2    | 0     | 0 | 0                         | 2    | 0     | 0 | 5     | 64            |
| 12:15 PM                        | 0                       | 0    | 0     | 0 | 0                       | 0    | 0     | 0 | 1                         | 1    | 1     | 0 | 0                         | 1    | 0     | 0 | 4     | 65            |
| 12:20 PM                        | 0                       | 0    | 0     | 0 | 0                       | 0    | 3     | 0 | 1                         | 1    | 1     | 0 | 0                         | 4    | 0     | 0 | 10    | 74            |
| 12:25 PM                        | 1                       | 0    | 0     | 0 | 0                       | 0    | 2     | 0 | 0                         | 2    | 1     | 0 | 0                         | 2    | 0     | 0 | 8     | 77            |
| 12:30 PM                        | 1                       | 0    | 1     | 0 | 0                       | 0    | 0     | 0 | 0                         | 1    | 0     | 0 | 0                         | 2    | 0     | 0 | 5     | 75            |
| 12:35 PM                        | 0                       | 0    | 0     | 0 | 0                       | 0    | 0     | 0 | 1                         | 1    | 1     | 0 | 0                         | 1    | 0     | 0 | 4     | 72            |
| 12:40 PM                        | 0                       | 0    | 0     | 0 | 0                       | 0    | 1     | 0 | 0                         | 2    | 0     | 0 | 0                         | 1    | 1     | 0 | 5     | 74            |
| 12:45 PM                        | 0                       | 0    | 0     | 0 | 0                       | 0    | 2     | 0 | 0                         | 1    | 3     | 0 | 0                         | 4    | 0     | 0 | 10    | 75            |
| 12:50 PM                        | 0                       | 0    | 1     | 0 | 0                       | 0    | 1     | 0 | 1                         | 2    | 1     | 0 | 0                         | 2    | 0     | 0 | 8     | 82            |
| 12:55 PM                        | 0                       | 0    | 0     | 0 | 0                       | 0    | 0     | 0 | 0                         | 3    | 0     | 0 | 0                         | 5    | 0     | 0 | 8     | 85            |
| 1:00 PM                         | 1                       | 0    | 0     | 0 | 0                       | 0    | 1     | 0 | 2                         | 2    | 1     | 0 | 0                         | 4    | 0     | 0 | 11    | 88            |
| 1:05 PM                         | 0                       | 0    | 0     | 0 | 0                       | 0    | 1     | 0 | 0                         | 2    | 0     | 0 | 0                         | 2    | 0     | 0 | 5     | 83            |
| 1:10 PM                         | 1                       | 0    | 0     | 0 | 0                       | 0    | 3     | 0 | 2                         | 2    | 1     | 0 | 0                         | 0    | 0     | 0 | 9     | 87            |
| 1:15 PM                         | 0                       | 0    | 0     | 0 | 0                       | 0    | 0     | 0 | 0                         | 1    | 1     | 0 | 0                         | 0    | 0     | 0 | 2     | 85            |
| 1:20 PM                         | 2                       | 0    | 0     | 0 | 0                       | 0    | 1     | 0 | 3                         | 2    | 1     | 0 | 0                         | 0    | 0     | 0 | 9     | 84            |
| 1:25 PM                         | 0                       | 0    | 1     | 0 | 0                       | 0    | 0     | 0 | 3                         | 2    | 1     | 0 | 0                         | 1    | 0     | 0 | 8     | 84            |
| 1:30 PM                         | 0                       | 0    | 0     | 0 | 0                       | 0    | 2     | 0 | 1                         | 0    | 0     | 0 | 0                         | 0    | 0     | 0 | 3     | 82            |
| 1:35 PM                         | 0                       | 0    | 0     | 0 | 0                       | 0    | 1     | 0 | 3                         | 2    | 0     | 0 | 0                         | 3    | 0     | 0 | 9     | 87            |
| 1:40 PM                         | 1                       | 0    | 0     | 0 | 0                       | 0    | 1     | 0 | 1                         | 2    | 0     | 0 | 0                         | 1    | 0     | 0 | 6     | 88            |
| 1:45 PM                         | 1                       | 0    | 0     | 0 | 0                       | 0    | 1     | 0 | 1                         | 2    | 0     | 0 | 0                         | 2    | 0     | 0 | 7     | 85            |
| 1:50 PM                         | 0                       | 0    | 0     | 0 | 0                       | 0    | 0     | 0 | 0                         | 3    | 0     | 0 | 0                         | 2    | 0     | 0 | 5     | 82            |
| 1:55 PM                         | 0                       | 0    | 0     | 0 | 0                       | 0    | 1     | 0 | 2                         | 0    | 1     | 0 | 0                         | 2    | 0     | 0 | 6     | 80            |
| 2:00 PM                         | 0                       | 0    | 0     | 0 | 0                       | 0    | 0     | 0 | 1                         | 1    | 0     | 0 | 0                         | 4    | 0     | 0 | 6     | 75            |
| 2:05 PM                         | 2                       | 0    | 0     | 0 | 0                       | 0    | 2     | 0 | 0                         | 6    | 0     | 0 | 0                         | 0    | 0     | 0 | 10    | 80            |
| 2:10 PM                         | 0                       | 0    | 1     | 0 | 0                       | 0    | 0     | 0 | 0                         | 0    | 1     | 0 | 0                         | 3    | 0     | 0 | 5     | 76            |
| 2:15 PM                         | 0                       | 0    | 0     | 0 | 0                       | 0    | 2     | 0 | 1                         | 2    | 2     | 0 | 0                         | 2    | 0     | 0 | 9     | 83            |
| 2:20 PM                         | 0                       | 0    | 1     | 0 | 1                       | 0    | 0     | 0 | 0                         | 1    | 0     | 0 | 0                         | 3    | 0     | 0 | 6     | 80            |
| 2:25 PM                         | 0                       | 0    | 0     | 0 | 0                       | 0    | 1     | 0 | 0                         | 0    | 2     | 0 | 0                         | 2    | 0     | 0 | 5     | 77            |
| 2:30 PM                         | 1                       | 0    | 0     | 0 | 0                       | 0    | 1     | 0 | 1                         | 3    | 0     | 0 | 0                         | 1    | 0     | 0 | 7     | 81            |
| 2:35 PM                         | 0                       | 0    | 0     | 0 | 0                       | 0    | 2     | 0 | 2                         | 2    | 0     | 0 | 0                         | 2    | 0     | 0 | 8     | 80            |
| 2:40 PM                         | 1                       | 0    | 0     | 0 | 1                       | 0    | 1     | 0 | 0                         | 1    | 0     | 0 | 0                         | 2    | 0     | 0 | 6     | 80            |
| 2:45 PM                         | 0                       | 0    | 0     | 0 | 0                       | 0    | 0     | 0 | 0                         | 0    | 0     | 0 | 0                         | 1    | 0     | 0 | 1     | 74            |
| 2:50 PM                         | 1                       | 0    | 0     | 0 | 0                       | 0    | 2     | 0 | 1                         | 0    | 0     | 0 | 0                         | 1    | 0     | 0 | 5     | 74            |
| 2:55 PM                         | 0                       | 0    | 0     | 0 | 0                       | 0    | 1     | 0 | 1                         | 3    | 1     | 0 | 0                         | 1    | 0     | 0 | 7     | 75            |
| 3:00 PM                         | 1                       | 0    | 0     | 0 | 0                       | 0    | 1     | 0 | 5                         | 2    | 0     | 0 | 0                         | 3    | 0     | 0 | 12    | 81            |
| 3:05 PM                         | 0                       | 0    | 0     | 0 | 0                       | 0    | 0     | 0 | 0                         | 4    | 0     | 0 | 0                         | 1    | 0     | 0 | 5     | 76            |
| 3:10 PM                         | 0                       | 0    | 0     | 0 | 0                       | 0    | 0     | 0 | 2                         | 4    | 0     | 0 | 0                         | 3    | 0     | 0 | 9     | 80            |
| 3:15 PM                         | 0                       | 0    | 0     | 0 | 1                       | 0    | 1     | 0 | 1                         | 4    | 0     | 0 | 0                         | 4    | 0     | 0 | 11    | 82            |
| 3:20 PM                         | 0                       | 0    | 0     | 0 | 0                       | 0    | 0     | 0 | 0                         | 4    | 0     | 0 | 0                         | 3    | 0     | 0 | 7     | 83            |
| 3:25 PM                         | 0                       | 0    | 0     | 0 | 0                       | 0    | 2     | 0 | 1                         | 4    | 0     | 0 | 0                         | 3    | 1     | 0 | 11    | 89            |
| 3:30 PM                         | 1                       | 0    | 0     | 0 | 0                       | 0    | 1     | 0 | 3                         | 7    | 0     | 0 | 0                         | 6    | 0     | 0 | 18    | 100           |
| 3:35 PM                         | 2                       | 0    | 0     | 0 | 0                       | 1    | 0     | 0 | 1                         | 3    | 0     | 0 | 0                         | 4    | 0     | 0 | 11    | 103           |
| 3:40 PM                         | 0                       | 0    | 0     | 0 | 0                       | 0    | 2     | 0 | 0                         | 1    | 0     | 0 | 0                         | 3    | 0     | 0 | 6     | 103           |
| 3:45 PM                         | 0                       | 0    | 1     | 0 | 0                       | 0    | 2     | 0 | 1                         | 1    | 0     | 0 | 0                         | 3    | 0     | 0 | 8     | 110           |
| 3:50 PM                         | 2                       | 0    | 0     | 0 | 0                       | 0    | 0     | 0 | 0                         | 2    | 0     | 0 | 0                         | 3    | 0     | 0 | 7     | 112           |
| 3:55 PM                         | 0                       | 0    | 0     | 0 | 0                       | 0    | 1     | 0 | 1                         | 6    | 1     | 0 | 0                         | 2    | 0     | 0 | 11    | 116           |
| 4:00 PM                         | 0                       | 0    | 0     | 0 | 0                       | 0    | 0     | 0 | 2                         | 2    | 0     | 0 | 0                         | 3    | 0     | 0 | 7     | 111           |
| 4:05 PM                         | 2                       | 0    | 0     | 0 | 0                       | 0    | 3     | 0 | 0                         | 4    | 0     | 0 | 0                         | 1    | 0     | 0 | 10    | 116           |
| 4:10 PM                         | 0                       | 0    | 0     | 0 | 0                       | 0    | 0     | 0 | 0                         | 1    | 1     | 0 | 0                         | 0    | 0     | 0 | 2     | 109           |
| 4:15 PM                         | 0                       | 0    | 0     | 0 | 0                       | 0    | 0     | 0 | 1                         | 4    | 0     | 0 | 0                         | 3    | 0     | 0 | 8     | 106           |
| 4:20 PM                         | 0                       | 0    | 0     | 0 | 0                       | 0    | 0     | 0 | 1                         | 5    | 2     | 0 | 0                         | 4    | 0     | 0 | 12    | 111           |
| 4:25 PM                         | 0                       | 0    | 0     | 0 | 0                       | 0    | 0     | 0 | 0                         | 5    | 0     | 0 | 0                         | 2    | 0     | 0 | 7     | 107           |
| 4:30 PM                         | 0                       | 0    | 0     | 0 | 0                       | 0    | 0     | 0 | 0                         | 9    | 0     | 0 | 0                         | 7    | 0     | 0 | 16    | 105           |

**Attachment B**

| 5-Min Count Period Beginning At | Shively Rd (Northbound) |      |       |   | Shively Rd (Southbound) |      |       |   | Ranunculus St (Eastbound) |      |       |   | Ranunculus St (Westbound) |      |       |   | Total | Hourly Totals |
|---------------------------------|-------------------------|------|-------|---|-------------------------|------|-------|---|---------------------------|------|-------|---|---------------------------|------|-------|---|-------|---------------|
|                                 | Left                    | Thru | Right | U | Left                    | Thru | Right | U | Left                      | Thru | Right | U | Left                      | Thru | Right | U |       |               |
| 4:35 PM                         | 0                       | 0    | 0     | 0 | 0                       | 0    | 0     | 0 | 0                         | 3    | 0     | 0 | 0                         | 9    | 0     | 0 | 12    | 106           |
| 4:40 PM                         | 0                       | 0    | 0     | 0 | 0                       | 0    | 0     | 0 | 1                         | 4    | 0     | 0 | 0                         | 1    | 0     | 0 | 6     | 106           |
| 4:45 PM                         | 0                       | 0    | 0     | 0 | 0                       | 0    | 0     | 0 | 1                         | 3    | 0     | 0 | 0                         | 2    | 0     | 0 | 6     | 104           |
| 4:50 PM                         | 0                       | 0    | 0     | 0 | 0                       | 0    | 2     | 0 | 4                         | 2    | 2     | 0 | 0                         | 0    | 0     | 0 | 10    | 107           |
| 4:55 PM                         | 0                       | 0    | 0     | 0 | 0                       | 0    | 1     | 0 | 0                         | 5    | 0     | 0 | 0                         | 8    | 0     | 0 | 14    | 110           |
| 5:00 PM                         | 0                       | 0    | 0     | 0 | 0                       | 0    | 1     | 0 | 1                         | 0    | 0     | 0 | 0                         | 1    | 1     | 0 | 4     | 107           |
| 5:05 PM                         | 0                       | 0    | 0     | 0 | 0                       | 0    | 2     | 0 | 0                         | 5    | 1     | 0 | 0                         | 4    | 0     | 0 | 12    | 109           |
| 5:10 PM                         | 1                       | 0    | 0     | 0 | 0                       | 0    | 2     | 0 | 0                         | 2    | 1     | 0 | 0                         | 0    | 0     | 0 | 6     | 113           |
| 5:15 PM                         | 1                       | 0    | 0     | 0 | 0                       | 0    | 0     | 0 | 0                         | 1    | 1     | 0 | 0                         | 3    | 0     | 0 | 6     | 111           |
| 5:20 PM                         | 2                       | 0    | 0     | 0 | 0                       | 0    | 0     | 0 | 1                         | 7    | 0     | 0 | 0                         | 0    | 0     | 0 | 10    | 109           |
| 5:25 PM                         | 1                       | 0    | 0     | 0 | 0                       | 0    | 0     | 0 | 0                         | 5    | 0     | 0 | 1                         | 4    | 0     | 0 | 11    | 113           |
| 5:30 PM                         | 0                       | 0    | 0     | 0 | 0                       | 0    | 0     | 0 | 1                         | 3    | 1     | 0 | 0                         | 6    | 0     | 0 | 11    | 108           |
| 5:35 PM                         | 1                       | 0    | 0     | 0 | 0                       | 0    | 1     | 0 | 1                         | 3    | 2     | 0 | 0                         | 6    | 0     | 0 | 14    | 110           |
| 5:40 PM                         | 0                       | 0    | 0     | 0 | 0                       | 0    | 0     | 0 | 1                         | 0    | 1     | 0 | 0                         | 4    | 0     | 0 | 6     | 110           |
| 5:45 PM                         | 0                       | 0    | 0     | 0 | 1                       | 0    | 3     | 0 | 1                         | 4    | 0     | 0 | 0                         | 5    | 0     | 0 | 14    | 118           |
| 5:50 PM                         | 2                       | 0    | 0     | 0 | 0                       | 0    | 1     | 0 | 2                         | 1    | 0     | 0 | 0                         | 4    | 0     | 0 | 10    | 118           |
| 5:55 PM                         | 0                       | 0    | 0     | 0 | 0                       | 0    | 0     | 0 | 0                         | 2    | 0     | 0 | 0                         | 1    | 0     | 0 | 3     | 107           |
| 6:00 PM                         | 0                       | 0    | 0     | 0 | 0                       | 0    | 1     | 0 | 1                         | 4    | 0     | 0 | 0                         | 1    | 0     | 0 | 7     | 110           |
| 6:05 PM                         | 0                       | 0    | 0     | 0 | 0                       | 0    | 0     | 0 | 1                         | 5    | 0     | 0 | 0                         | 0    | 0     | 0 | 6     | 104           |
| 6:10 PM                         | 0                       | 0    | 0     | 0 | 0                       | 0    | 2     | 0 | 0                         | 1    | 0     | 0 | 0                         | 1    | 0     | 0 | 4     | 102           |
| 6:15 PM                         | 0                       | 0    | 0     | 0 | 0                       | 0    | 0     | 0 | 0                         | 2    | 0     | 0 | 0                         | 3    | 0     | 0 | 5     | 101           |
| 6:20 PM                         | 0                       | 0    | 0     | 0 | 0                       | 0    | 0     | 0 | 1                         | 1    | 0     | 0 | 0                         | 1    | 0     | 0 | 3     | 94            |
| 6:25 PM                         | 0                       | 0    | 0     | 0 | 0                       | 0    | 0     | 0 | 0                         | 1    | 0     | 0 | 0                         | 2    | 0     | 0 | 3     | 86            |
| 6:30 PM                         | 1                       | 0    | 0     | 0 | 0                       | 0    | 1     | 0 | 2                         | 3    | 2     | 0 | 0                         | 3    | 0     | 0 | 12    | 87            |
| 6:35 PM                         | 0                       | 0    | 0     | 0 | 0                       | 0    | 0     | 0 | 3                         | 4    | 1     | 0 | 0                         | 2    | 0     | 0 | 10    | 83            |
| 6:40 PM                         | 1                       | 0    | 0     | 0 | 0                       | 0    | 2     | 0 | 0                         | 4    | 0     | 0 | 0                         | 2    | 0     | 0 | 9     | 86            |
| 6:45 PM                         | 0                       | 0    | 0     | 0 | 0                       | 0    | 2     | 0 | 0                         | 7    | 0     | 0 | 0                         | 2    | 0     | 0 | 11    | 83            |
| 6:50 PM                         | 0                       | 0    | 0     | 0 | 0                       | 0    | 0     | 0 | 1                         | 3    | 0     | 0 | 0                         | 4    | 0     | 0 | 9     | 82            |
| 6:55 PM                         | 0                       | 0    | 0     | 0 | 0                       | 0    | 1     | 0 | 1                         | 3    | 2     | 0 | 0                         | 1    | 0     | 0 | 8     | 87            |
| 7:00 PM                         | 0                       | 0    | 0     | 0 | 0                       | 0    | 0     | 0 | 0                         | 0    | 0     | 0 | 0                         | 0    | 0     | 0 | 0     | 80            |
| 7:05 PM                         | 1                       | 0    | 0     | 0 | 0                       | 0    | 0     | 0 | 1                         | 1    | 0     | 0 | 0                         | 1    | 0     | 0 | 4     | 78            |
| 7:10 PM                         | 0                       | 0    | 0     | 0 | 0                       | 0    | 0     | 0 | 0                         | 2    | 2     | 0 | 1                         | 1    | 0     | 0 | 6     | 80            |
| 7:15 PM                         | 1                       | 0    | 0     | 0 | 0                       | 0    | 0     | 0 | 1                         | 2    | 0     | 0 | 0                         | 2    | 0     | 0 | 6     | 81            |
| 7:20 PM                         | 0                       | 0    | 0     | 0 | 0                       | 0    | 1     | 0 | 0                         | 5    | 0     | 0 | 0                         | 0    | 0     | 0 | 6     | 84            |
| 7:25 PM                         | 0                       | 0    | 0     | 0 | 0                       | 0    | 0     | 0 | 2                         | 3    | 2     | 0 | 0                         | 2    | 0     | 0 | 9     | 90            |
| 7:30 PM                         | 0                       | 0    | 0     | 0 | 0                       | 0    | 0     | 0 | 1                         | 2    | 0     | 0 | 0                         | 2    | 0     | 0 | 5     | 83            |
| 7:35 PM                         | 0                       | 0    | 0     | 0 | 0                       | 0    | 0     | 0 | 1                         | 1    | 0     | 0 | 0                         | 1    | 0     | 0 | 3     | 76            |
| 7:40 PM                         | 0                       | 0    | 0     | 0 | 0                       | 0    | 0     | 0 | 0                         | 1    | 1     | 0 | 0                         | 0    | 0     | 0 | 2     | 69            |
| 7:45 PM                         | 0                       | 0    | 0     | 0 | 0                       | 0    | 1     | 0 | 1                         | 2    | 0     | 0 | 0                         | 1    | 0     | 0 | 5     | 63            |
| 7:50 PM                         | 0                       | 0    | 0     | 0 | 0                       | 0    | 0     | 0 | 0                         | 1    | 0     | 0 | 0                         | 0    | 0     | 0 | 1     | 55            |
| 7:55 PM                         | 0                       | 0    | 0     | 0 | 0                       | 0    | 0     | 0 | 1                         | 2    | 0     | 0 | 0                         | 2    | 0     | 0 | 5     | 52            |
| 8:00 PM                         | 0                       | 0    | 0     | 0 | 0                       | 0    | 0     | 0 | 1                         | 1    | 0     | 0 | 0                         | 1    | 0     | 0 | 3     | 55            |
| 8:05 PM                         | 0                       | 0    | 0     | 0 | 0                       | 0    | 1     | 0 | 3                         | 1    | 0     | 0 | 0                         | 3    | 0     | 0 | 8     | 59            |
| 8:10 PM                         | 0                       | 0    | 0     | 0 | 0                       | 0    | 0     | 0 | 0                         | 2    | 0     | 0 | 0                         | 1    | 0     | 0 | 3     | 56            |
| 8:15 PM                         | 0                       | 0    | 0     | 0 | 0                       | 0    | 0     | 0 | 0                         | 3    | 0     | 0 | 0                         | 0    | 0     | 0 | 3     | 53            |
| 8:20 PM                         | 0                       | 0    | 0     | 0 | 0                       | 0    | 0     | 0 | 0                         | 1    | 0     | 0 | 0                         | 2    | 0     | 0 | 3     | 50            |
| 8:25 PM                         | 0                       | 0    | 0     | 0 | 0                       | 0    | 1     | 0 | 2                         | 0    | 0     | 0 | 0                         | 0    | 0     | 0 | 3     | 44            |
| 8:30 PM                         | 1                       | 0    | 0     | 0 | 0                       | 0    | 0     | 0 | 1                         | 0    | 1     | 0 | 0                         | 0    | 0     | 0 | 3     | 42            |
| 8:35 PM                         | 0                       | 0    | 0     | 0 | 0                       | 0    | 1     | 0 | 1                         | 2    | 0     | 0 | 0                         | 0    | 1     | 0 | 5     | 44            |
| 8:40 PM                         | 0                       | 0    | 0     | 0 | 0                       | 0    | 0     | 0 | 0                         | 1    | 0     | 0 | 0                         | 0    | 0     | 0 | 1     | 43            |
| 8:45 PM                         | 0                       | 0    | 0     | 0 | 0                       | 0    | 0     | 0 | 0                         | 1    | 0     | 0 | 0                         | 0    | 0     | 0 | 1     | 39            |
| 8:50 PM                         | 0                       | 0    | 0     | 0 | 0                       | 0    | 0     | 0 | 0                         | 0    | 0     | 1 | 0                         | 0    | 0     | 0 | 1     | 39            |
| 8:55 PM                         | 0                       | 0    | 0     | 0 | 0                       | 0    | 0     | 0 | 2                         | 1    | 1     | 0 | 0                         | 0    | 0     | 0 | 4     | 38            |
| 9:00 PM                         | 0                       | 0    | 0     | 0 | 0                       | 0    | 0     | 0 | 1                         | 0    | 0     | 0 | 0                         | 0    | 0     | 0 | 1     | 36            |
| 9:05 PM                         | 0                       | 0    | 0     | 0 | 0                       | 0    | 0     | 0 | 1                         | 2    | 0     | 0 | 0                         | 0    | 0     | 0 | 3     | 31            |
| 9:10 PM                         | 0                       | 0    | 0     | 0 | 0                       | 0    | 0     | 0 | 1                         | 3    | 0     | 0 | 0                         | 0    | 0     | 0 | 4     | 32            |
| 9:15 PM                         | 0                       | 0    | 0     | 0 | 0                       | 0    | 0     | 0 | 0                         | 1    | 0     | 0 | 0                         | 0    | 0     | 0 | 1     | 30            |
| 9:20 PM                         | 1                       | 0    | 0     | 0 | 0                       | 0    | 0     | 0 | 0                         | 2    | 0     | 0 | 0                         | 0    | 0     | 0 | 3     | 30            |
| 9:25 PM                         | 1                       | 0    | 0     | 0 | 0                       | 0    | 0     | 0 | 0                         | 0    | 0     | 0 | 0                         | 0    | 0     | 0 | 1     | 28            |
| 9:30 PM                         | 0                       | 0    | 0     | 0 | 0                       | 0    | 0     | 0 | 0                         | 2    | 0     | 0 | 0                         | 0    | 0     | 0 | 2     | 27            |
| 9:35 PM                         | 0                       | 0    | 0     | 0 | 0                       | 0    | 0     | 0 | 0                         | 0    | 1     | 0 | 0                         | 0    | 0     | 0 | 1     | 23            |
| 9:40 PM                         | 0                       | 0    | 0     | 0 | 0                       | 0    | 0     | 0 | 0                         | 1    | 0     | 0 | 0                         | 0    | 0     | 0 | 1     | 23            |
| 9:45 PM                         | 0                       | 0    | 0     | 0 | 0                       | 0    | 0     | 0 | 1                         | 0    | 0     | 0 | 0                         | 0    | 0     | 0 | 1     | 23            |
| 9:50 PM                         | 0                       | 0    | 0     | 0 | 0                       | 0    | 0     | 0 | 0                         | 0    | 0     | 0 | 0                         | 0    | 0     | 0 | 0     | 22            |
| 9:55 PM                         | 0                       | 0    | 0     | 0 | 0                       | 0    | 0     | 0 | 0                         | 2    | 0     | 0 | 0                         | 0    | 0     | 0 | 2     | 20            |
| Peak 15-Min Flowrates           | Northbound              |      |       |   | Southbound              |      |       |   | Eastbound                 |      |       |   | Westbound                 |      |       |   | Total |               |
|                                 | Left                    | Thru | Right | U | Left                    | Thru | Right | U | Left                      | Thru | Right | U | Left                      | Thru | Right | U |       |               |
| All Vehicles                    | 8                       | 0    | 8     | 0 | 0                       | 0    | 20    | 0 | 16                        | 52   | 8     | 0 | 4                         | 60   | 0     | 0 | 176   |               |
| Heavy Trucks                    | 0                       | 0    | 0     | 0 | 0                       | 0    | 0     | 0 | 0                         | 0    | 0     | 0 | 0                         | 4    | 0     | 0 | 4     |               |
| Buses                           |                         |      |       |   |                         |      |       |   |                           |      |       |   |                           |      |       |   |       |               |
| Pedestrians                     |                         | 0    |       |   |                         | 8    |       |   |                           | 0    |       |   |                           | 0    |       |   | 8     |               |
| Bicycles                        | 0                       | 0    | 0     |   | 0                       | 0    | 0     |   | 0                         | 0    | 0     |   | 0                         | 0    | 0     |   | 0     |               |
| Scoters                         |                         |      |       |   |                         |      |       |   |                           |      |       |   |                           |      |       |   |       |               |
| <i>Comments:</i>                |                         |      |       |   |                         |      |       |   |                           |      |       |   |                           |      |       |   |       |               |

Report generated on 4/25/2025 4:03 PM

SOURCE: Quality Counts, LLC (<http://www.qualitycounts.net>) 1-877-580-2212

LOCATION: Langford Ln -- Ranunculus St  
 CITY/STATE: Ladera Ranch, CA

QC JOB #: 16966464  
 DATE: Wed, Apr 16 2025

Peak-Hour: 7:45 AM -- 8:45 AM  
 Peak 15-Min: 8:00 AM -- 8:15 AM

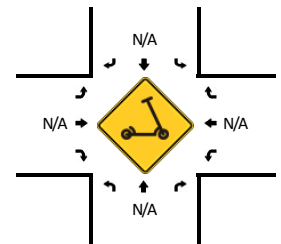
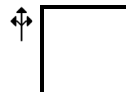
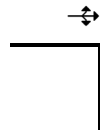
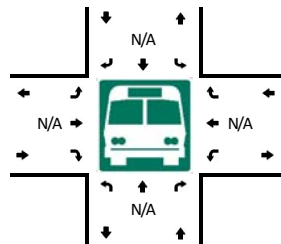
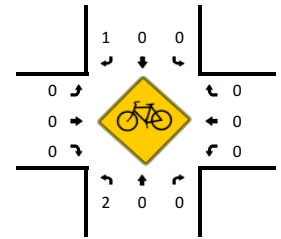
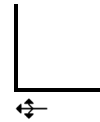
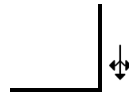
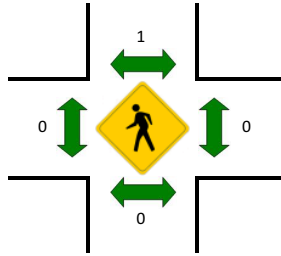
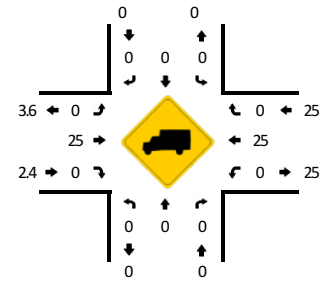
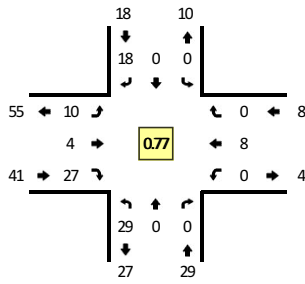

| 5-Min Count Period Beginning At | Langford Ln (Northbound) |      |       |   | Langford Ln (Southbound) |      |       |   | Ranunculus St (Eastbound) |      |       |   | Ranunculus St (Westbound) |      |       |   | Total | Hourly Totals |
|---------------------------------|--------------------------|------|-------|---|--------------------------|------|-------|---|---------------------------|------|-------|---|---------------------------|------|-------|---|-------|---------------|
|                                 | Left                     | Thru | Right | U | Left                     | Thru | Right | U | Left                      | Thru | Right | U | Left                      | Thru | Right | U |       |               |
| 6:00 AM                         | 1                        | 0    | 0     | 0 | 0                        | 0    | 0     | 0 | 0                         | 0    | 1     | 0 | 0                         | 0    | 0     | 0 | 2     |               |
| 6:05 AM                         | 0                        | 0    | 1     | 0 | 0                        | 0    | 2     | 0 | 2                         | 0    | 0     | 0 | 0                         | 0    | 1     | 0 | 6     |               |
| 6:10 AM                         | 0                        | 0    | 0     | 0 | 0                        | 0    | 2     | 0 | 0                         | 0    | 0     | 0 | 0                         | 0    | 0     | 0 | 2     |               |
| 6:15 AM                         | 0                        | 0    | 0     | 0 | 0                        | 0    | 1     | 0 | 0                         | 0    | 0     | 0 | 0                         | 0    | 0     | 0 | 1     |               |
| 6:20 AM                         | 0                        | 0    | 0     | 0 | 0                        | 0    | 0     | 0 | 0                         | 0    | 0     | 0 | 0                         | 0    | 0     | 0 | 0     |               |
| 6:25 AM                         | 0                        | 0    | 0     | 0 | 0                        | 0    | 0     | 0 | 0                         | 0    | 0     | 0 | 0                         | 0    | 0     | 0 | 0     |               |
| 6:30 AM                         | 0                        | 0    | 0     | 0 | 0                        | 0    | 0     | 0 | 0                         | 0    | 0     | 0 | 0                         | 0    | 0     | 0 | 0     |               |
| 6:35 AM                         | 1                        | 0    | 0     | 0 | 0                        | 0    | 0     | 0 | 0                         | 0    | 0     | 0 | 0                         | 1    | 0     | 0 | 2     |               |
| 6:40 AM                         | 0                        | 0    | 0     | 0 | 0                        | 0    | 0     | 0 | 0                         | 0    | 0     | 0 | 0                         | 0    | 0     | 0 | 0     |               |
| 6:45 AM                         | 0                        | 0    | 0     | 0 | 0                        | 0    | 2     | 0 | 1                         | 0    | 1     | 0 | 0                         | 0    | 0     | 0 | 4     |               |
| 6:50 AM                         | 0                        | 0    | 0     | 0 | 0                        | 0    | 3     | 0 | 0                         | 0    | 1     | 0 | 0                         | 0    | 0     | 0 | 4     |               |
| 6:55 AM                         | 1                        | 0    | 0     | 0 | 0                        | 0    | 1     | 0 | 0                         | 0    | 1     | 0 | 0                         | 0    | 0     | 0 | 3     | 24            |
| 7:00 AM                         | 2                        | 0    | 0     | 0 | 0                        | 0    | 1     | 0 | 0                         | 0    | 0     | 0 | 0                         | 0    | 0     | 0 | 3     | 25            |
| 7:05 AM                         | 1                        | 0    | 0     | 0 | 0                        | 0    | 1     | 0 | 0                         | 0    | 0     | 0 | 0                         | 0    | 0     | 0 | 2     | 21            |
| 7:10 AM                         | 1                        | 0    | 0     | 0 | 0                        | 0    | 3     | 0 | 0                         | 0    | 0     | 0 | 0                         | 0    | 0     | 0 | 4     | 23            |
| 7:15 AM                         | 4                        | 0    | 0     | 0 | 0                        | 1    | 1     | 0 | 0                         | 0    | 0     | 0 | 0                         | 0    | 0     | 0 | 6     | 28            |
| 7:20 AM                         | 1                        | 0    | 0     | 0 | 0                        | 0    | 0     | 0 | 1                         | 0    | 0     | 0 | 0                         | 1    | 0     | 0 | 3     | 31            |
| 7:25 AM                         | 1                        | 0    | 0     | 0 | 0                        | 0    | 1     | 0 | 1                         | 1    | 1     | 0 | 0                         | 0    | 0     | 0 | 5     | 36            |
| 7:30 AM                         | 1                        | 0    | 0     | 0 | 0                        | 0    | 0     | 0 | 0                         | 0    | 0     | 0 | 0                         | 0    | 0     | 0 | 1     | 37            |
| 7:35 AM                         | 3                        | 0    | 0     | 0 | 0                        | 0    | 1     | 0 | 1                         | 1    | 0     | 0 | 0                         | 0    | 0     | 0 | 6     | 41            |
| 7:40 AM                         | 1                        | 0    | 0     | 0 | 0                        | 0    | 2     | 0 | 0                         | 1    | 0     | 0 | 0                         | 0    | 0     | 0 | 4     | 45            |
| 7:45 AM                         | 4                        | 0    | 0     | 0 | 0                        | 0    | 2     | 0 | 1                         | 0    | 1     | 0 | 0                         | 1    | 0     | 0 | 9     | 50            |
| 7:50 AM                         | 3                        | 0    | 0     | 0 | 0                        | 0    | 2     | 0 | 0                         | 0    | 3     | 0 | 0                         | 0    | 0     | 0 | 8     | 54            |
| 7:55 AM                         | 4                        | 0    | 0     | 0 | 0                        | 0    | 2     | 0 | 0                         | 0    | 1     | 0 | 0                         | 0    | 0     | 0 | 7     | 58            |
| 8:00 AM                         | 2                        | 0    | 0     | 0 | 0                        | 0    | 2     | 0 | 0                         | 0    | 2     | 0 | 0                         | 1    | 0     | 0 | 7     | 62            |
| 8:05 AM                         | 1                        | 0    | 0     | 0 | 0                        | 0    | 4     | 0 | 4                         | 1    | 5     | 0 | 0                         | 1    | 0     | 0 | 16    | 76            |
| 8:10 AM                         | 5                        | 0    | 0     | 0 | 0                        | 0    | 1     | 0 | 1                         | 0    | 1     | 0 | 0                         | 0    | 0     | 0 | 8     | 80            |
| 8:15 AM                         | 0                        | 0    | 0     | 0 | 0                        | 0    | 1     | 0 | 1                         | 1    | 1     | 0 | 0                         | 2    | 0     | 0 | 6     | 80            |
| 8:20 AM                         | 1                        | 0    | 0     | 0 | 0                        | 0    | 2     | 0 | 0                         | 0    | 4     | 0 | 0                         | 0    | 0     | 0 | 7     | 84            |
| 8:25 AM                         | 1                        | 0    | 0     | 0 | 0                        | 0    | 0     | 0 | 1                         | 0    | 3     | 0 | 0                         | 1    | 0     | 0 | 6     | 85            |
| 8:30 AM                         | 3                        | 0    | 0     | 0 | 0                        | 0    | 1     | 0 | 1                         | 0    | 4     | 0 | 0                         | 0    | 0     | 0 | 9     | 93            |
| 8:35 AM                         | 2                        | 0    | 0     | 0 | 0                        | 0    | 1     | 0 | 0                         | 1    | 2     | 0 | 0                         | 2    | 0     | 0 | 8     | 95            |
| 8:40 AM                         | 3                        | 0    | 0     | 0 | 0                        | 0    | 0     | 0 | 1                         | 1    | 0     | 0 | 0                         | 0    | 0     | 0 | 5     | 96            |
| 8:45 AM                         | 1                        | 0    | 0     | 0 | 0                        | 0    | 3     | 0 | 0                         | 0    | 3     | 0 | 0                         | 1    | 0     | 0 | 8     | 95            |
| 8:50 AM                         | 2                        | 0    | 0     | 0 | 0                        | 0    | 1     | 0 | 0                         | 1    | 2     | 0 | 0                         | 0    | 0     | 0 | 6     | 93            |
| 8:55 AM                         | 2                        | 0    | 0     | 0 | 0                        | 0    | 0     | 0 | 0                         | 0    | 1     | 0 | 0                         | 1    | 0     | 0 | 4     | 90            |
| 9:00 AM                         | 1                        | 0    | 0     | 0 | 1                        | 0    | 1     | 0 | 1                         | 1    | 0     | 0 | 0                         | 0    | 0     | 0 | 5     | 88            |
| 9:05 AM                         | 0                        | 0    | 0     | 0 | 0                        | 0    | 1     | 0 | 0                         | 0    | 2     | 0 | 1                         | 1    | 0     | 0 | 5     | 77            |

**Attachment B**

| 5-Min Count Period Beginning At | Langford Ln (Northbound) |      |       |   | Langford Ln (Southbound) |      |       |   | Ranunculus St (Eastbound) |      |       |   | Ranunculus St (Westbound) |      |       |   | Total | Hourly Totals |
|---------------------------------|--------------------------|------|-------|---|--------------------------|------|-------|---|---------------------------|------|-------|---|---------------------------|------|-------|---|-------|---------------|
|                                 | Left                     | Thru | Right | U | Left                     | Thru | Right | U | Left                      | Thru | Right | U | Left                      | Thru | Right | U |       |               |
| 9:10 AM                         | 0                        | 0    | 0     | 0 | 0                        | 0    | 1     | 0 | 0                         | 0    | 0     | 0 | 0                         | 0    | 0     | 0 | 1     | 70            |
| 9:15 AM                         | 1                        | 0    | 0     | 0 | 0                        | 0    | 0     | 0 | 1                         | 0    | 0     | 0 | 0                         | 1    | 0     | 0 | 3     | 67            |
| 9:20 AM                         | 2                        | 0    | 0     | 0 | 0                        | 0    | 1     | 0 | 0                         | 0    | 0     | 0 | 0                         | 0    | 0     | 0 | 3     | 63            |
| 9:25 AM                         | 1                        | 0    | 0     | 0 | 0                        | 0    | 0     | 0 | 1                         | 0    | 1     | 0 | 0                         | 0    | 0     | 0 | 3     | 60            |
| 9:30 AM                         | 0                        | 0    | 0     | 0 | 0                        | 0    | 1     | 0 | 0                         | 0    | 0     | 0 | 0                         | 0    | 0     | 0 | 1     | 52            |
| 9:35 AM                         | 0                        | 0    | 0     | 0 | 0                        | 0    | 0     | 0 | 1                         | 1    | 0     | 0 | 0                         | 0    | 0     | 0 | 2     | 46            |
| 9:40 AM                         | 1                        | 0    | 0     | 0 | 0                        | 0    | 0     | 0 | 0                         | 0    | 0     | 0 | 0                         | 0    | 0     | 0 | 1     | 42            |
| 9:45 AM                         | 1                        | 0    | 0     | 0 | 0                        | 0    | 1     | 0 | 0                         | 0    | 0     | 0 | 0                         | 0    | 0     | 0 | 2     | 36            |
| 9:50 AM                         | 0                        | 0    | 0     | 0 | 0                        | 0    | 0     | 0 | 0                         | 0    | 0     | 0 | 0                         | 0    | 0     | 0 | 0     | 30            |
| 9:55 AM                         | 0                        | 0    | 0     | 0 | 0                        | 0    | 0     | 0 | 0                         | 0    | 0     | 0 | 0                         | 0    | 0     | 0 | 0     | 26            |
| 10:00 AM                        | 0                        | 0    | 0     | 0 | 0                        | 0    | 0     | 0 | 3                         | 1    | 0     | 0 | 0                         | 0    | 0     | 0 | 4     | 25            |
| 10:05 AM                        | 1                        | 0    | 0     | 0 | 0                        | 0    | 1     | 0 | 1                         | 0    | 0     | 0 | 0                         | 0    | 0     | 0 | 3     | 23            |
| 10:10 AM                        | 1                        | 0    | 0     | 0 | 0                        | 0    | 1     | 0 | 0                         | 2    | 0     | 0 | 0                         | 0    | 0     | 0 | 4     | 26            |
| 10:15 AM                        | 0                        | 0    | 0     | 0 | 0                        | 0    | 0     | 0 | 1                         | 0    | 0     | 0 | 0                         | 0    | 0     | 0 | 1     | 24            |
| 10:20 AM                        | 0                        | 0    | 0     | 0 | 0                        | 0    | 4     | 0 | 0                         | 0    | 0     | 0 | 0                         | 1    | 0     | 0 | 5     | 26            |
| 10:25 AM                        | 0                        | 0    | 0     | 0 | 0                        | 0    | 1     | 0 | 0                         | 0    | 0     | 0 | 0                         | 2    | 0     | 0 | 3     | 26            |
| 10:30 AM                        | 0                        | 0    | 0     | 0 | 0                        | 0    | 0     | 0 | 1                         | 0    | 1     | 0 | 0                         | 1    | 0     | 0 | 3     | 28            |
| 10:35 AM                        | 1                        | 0    | 0     | 0 | 0                        | 0    | 0     | 0 | 4                         | 1    | 0     | 0 | 0                         | 0    | 0     | 0 | 6     | 32            |
| 10:40 AM                        | 0                        | 0    | 0     | 0 | 0                        | 0    | 1     | 0 | 0                         | 0    | 0     | 0 | 0                         | 1    | 0     | 0 | 2     | 33            |
| 10:45 AM                        | 0                        | 0    | 0     | 0 | 0                        | 0    | 1     | 0 | 0                         | 0    | 0     | 0 | 0                         | 1    | 0     | 0 | 2     | 33            |
| 10:50 AM                        | 0                        | 0    | 0     | 0 | 0                        | 0    | 0     | 0 | 2                         | 1    | 0     | 0 | 0                         | 0    | 0     | 0 | 3     | 36            |
| 10:55 AM                        | 1                        | 0    | 0     | 0 | 0                        | 0    | 0     | 0 | 0                         | 0    | 2     | 0 | 0                         | 1    | 0     | 0 | 4     | 40            |
| 11:00 AM                        | 0                        | 0    | 0     | 0 | 0                        | 0    | 1     | 0 | 2                         | 0    | 1     | 0 | 0                         | 0    | 0     | 0 | 4     | 40            |
| 11:05 AM                        | 0                        | 0    | 0     | 0 | 0                        | 0    | 0     | 0 | 0                         | 0    | 0     | 0 | 0                         | 0    | 0     | 0 | 0     | 37            |
| 11:10 AM                        | 0                        | 0    | 0     | 0 | 0                        | 0    | 0     | 0 | 0                         | 0    | 0     | 0 | 0                         | 0    | 0     | 0 | 0     | 33            |
| 11:15 AM                        | 1                        | 0    | 0     | 0 | 0                        | 0    | 0     | 0 | 0                         | 0    | 1     | 0 | 0                         | 0    | 0     | 0 | 2     | 34            |
| 11:20 AM                        | 1                        | 0    | 0     | 0 | 0                        | 0    | 0     | 0 | 0                         | 0    | 0     | 0 | 0                         | 0    | 0     | 0 | 1     | 30            |
| 11:25 AM                        | 2                        | 0    | 0     | 0 | 0                        | 0    | 0     | 0 | 0                         | 0    | 1     | 0 | 0                         | 0    | 0     | 0 | 3     | 30            |
| 11:30 AM                        | 2                        | 0    | 0     | 0 | 0                        | 0    | 1     | 0 | 1                         | 0    | 1     | 0 | 0                         | 0    | 0     | 0 | 5     | 32            |
| 11:35 AM                        | 0                        | 0    | 0     | 0 | 0                        | 0    | 2     | 0 | 0                         | 0    | 0     | 0 | 0                         | 0    | 0     | 0 | 2     | 28            |
| 11:40 AM                        | 0                        | 0    | 0     | 0 | 0                        | 0    | 0     | 0 | 0                         | 0    | 1     | 0 | 0                         | 1    | 0     | 0 | 2     | 28            |
| 11:45 AM                        | 1                        | 0    | 0     | 0 | 0                        | 0    | 0     | 0 | 0                         | 1    | 1     | 0 | 0                         | 1    | 0     | 0 | 4     | 30            |
| 11:50 AM                        | 0                        | 0    | 0     | 0 | 0                        | 0    | 1     | 0 | 0                         | 0    | 0     | 0 | 0                         | 0    | 0     | 0 | 1     | 28            |
| 11:55 AM                        | 1                        | 0    | 0     | 0 | 0                        | 0    | 0     | 0 | 0                         | 0    | 2     | 0 | 0                         | 0    | 0     | 0 | 3     | 27            |
| 12:00 PM                        | 1                        | 0    | 0     | 0 | 0                        | 0    | 0     | 0 | 1                         | 0    | 1     | 0 | 0                         | 0    | 0     | 0 | 3     | 26            |
| 12:05 PM                        | 1                        | 0    | 1     | 0 | 0                        | 0    | 2     | 0 | 4                         | 1    | 1     | 0 | 0                         | 0    | 1     | 0 | 11    | 37            |
| 12:10 PM                        | 0                        | 0    | 1     | 0 | 0                        | 0    | 1     | 0 | 1                         | 1    | 0     | 0 | 0                         | 1    | 0     | 0 | 5     | 42            |
| 12:15 PM                        | 1                        | 0    | 0     | 0 | 0                        | 0    | 1     | 0 | 0                         | 0    | 1     | 0 | 0                         | 0    | 0     | 0 | 3     | 43            |
| 12:20 PM                        | 1                        | 0    | 0     | 0 | 0                        | 0    | 0     | 0 | 0                         | 0    | 1     | 0 | 0                         | 1    | 0     | 0 | 3     | 45            |
| 12:25 PM                        | 0                        | 0    | 0     | 0 | 0                        | 0    | 2     | 0 | 0                         | 0    | 2     | 0 | 0                         | 0    | 0     | 0 | 4     | 46            |
| 12:30 PM                        | 1                        | 0    | 1     | 0 | 0                        | 0    | 1     | 0 | 0                         | 0    | 2     | 0 | 0                         | 0    | 0     | 0 | 5     | 46            |
| 12:35 PM                        | 1                        | 0    | 0     | 0 | 0                        | 0    | 0     | 0 | 0                         | 0    | 1     | 0 | 0                         | 0    | 1     | 0 | 3     | 47            |
| 12:40 PM                        | 0                        | 0    | 0     | 0 | 0                        | 0    | 2     | 0 | 1                         | 1    | 0     | 0 | 0                         | 0    | 0     | 0 | 4     | 49            |
| 12:45 PM                        | 2                        | 0    | 0     | 0 | 0                        | 0    | 2     | 0 | 0                         | 0    | 1     | 0 | 0                         | 0    | 0     | 0 | 5     | 50            |
| 12:50 PM                        | 2                        | 0    | 0     | 0 | 0                        | 0    | 0     | 0 | 0                         | 0    | 3     | 0 | 0                         | 0    | 0     | 0 | 5     | 54            |
| 12:55 PM                        | 4                        | 0    | 0     | 0 | 0                        | 0    | 1     | 0 | 0                         | 2    | 1     | 0 | 0                         | 0    | 0     | 0 | 8     | 59            |
| 1:00 PM                         | 3                        | 0    | 0     | 0 | 0                        | 0    | 0     | 0 | 1                         | 0    | 1     | 0 | 0                         | 1    | 0     | 0 | 6     | 62            |
| 1:05 PM                         | 1                        | 0    | 0     | 0 | 0                        | 0    | 1     | 0 | 0                         | 0    | 2     | 0 | 0                         | 0    | 1     | 0 | 5     | 56            |
| 1:10 PM                         | 0                        | 0    | 0     | 0 | 0                        | 0    | 0     | 0 | 1                         | 0    | 1     | 0 | 0                         | 0    | 0     | 0 | 2     | 53            |
| 1:15 PM                         | 0                        | 0    | 0     | 0 | 0                        | 0    | 0     | 0 | 0                         | 0    | 1     | 0 | 0                         | 0    | 0     | 0 | 1     | 51            |
| 1:20 PM                         | 0                        | 0    | 0     | 0 | 0                        | 0    | 0     | 0 | 1                         | 0    | 1     | 0 | 0                         | 0    | 0     | 0 | 2     | 50            |
| 1:25 PM                         | 1                        | 0    | 0     | 0 | 0                        | 0    | 0     | 0 | 1                         | 0    | 2     | 0 | 0                         | 0    | 0     | 0 | 4     | 50            |
| 1:30 PM                         | 0                        | 0    | 1     | 0 | 0                        | 0    | 0     | 0 | 0                         | 0    | 0     | 0 | 0                         | 0    | 1     | 0 | 2     | 47            |
| 1:35 PM                         | 0                        | 0    | 0     | 0 | 0                        | 0    | 3     | 0 | 0                         | 0    | 2     | 0 | 0                         | 0    | 0     | 0 | 5     | 49            |
| 1:40 PM                         | 1                        | 0    | 0     | 0 | 0                        | 0    | 0     | 0 | 1                         | 0    | 1     | 0 | 0                         | 0    | 0     | 0 | 3     | 48            |
| 1:45 PM                         | 0                        | 0    | 0     | 0 | 0                        | 0    | 1     | 0 | 1                         | 0    | 1     | 0 | 0                         | 1    | 0     | 0 | 4     | 47            |
| 1:50 PM                         | 0                        | 0    | 0     | 0 | 0                        | 0    | 2     | 0 | 0                         | 0    | 3     | 0 | 0                         | 0    | 0     | 0 | 5     | 47            |
| 1:55 PM                         | 1                        | 0    | 0     | 0 | 0                        | 0    | 1     | 0 | 0                         | 0    | 0     | 0 | 0                         | 0    | 0     | 0 | 2     | 41            |
| 2:00 PM                         | 2                        | 0    | 0     | 0 | 0                        | 0    | 2     | 0 | 1                         | 0    | 0     | 0 | 0                         | 0    | 0     | 0 | 5     | 40            |
| 2:05 PM                         | 0                        | 0    | 0     | 0 | 0                        | 0    | 0     | 0 | 4                         | 1    | 0     | 0 | 0                         | 0    | 0     | 0 | 5     | 40            |
| 2:10 PM                         | 0                        | 0    | 0     | 0 | 0                        | 0    | 2     | 0 | 1                         | 1    | 0     | 0 | 0                         | 1    | 0     | 0 | 5     | 43            |
| 2:15 PM                         | 2                        | 0    | 0     | 0 | 0                        | 0    | 0     | 0 | 0                         | 0    | 2     | 0 | 0                         | 0    | 0     | 0 | 4     | 46            |
| 2:20 PM                         | 2                        | 0    | 0     | 0 | 0                        | 0    | 1     | 0 | 2                         | 0    | 1     | 0 | 0                         | 0    | 0     | 0 | 6     | 50            |
| 2:25 PM                         | 2                        | 0    | 0     | 0 | 0                        | 0    | 0     | 0 | 0                         | 0    | 0     | 0 | 0                         | 0    | 0     | 0 | 2     | 48            |
| 2:30 PM                         | 0                        | 0    | 0     | 0 | 0                        | 0    | 1     | 0 | 2                         | 0    | 1     | 0 | 0                         | 0    | 0     | 0 | 4     | 50            |
| 2:35 PM                         | 1                        | 0    | 0     | 0 | 0                        | 0    | 1     | 0 | 1                         | 1    | 0     | 0 | 0                         | 0    | 0     | 0 | 4     | 49            |
| 2:40 PM                         | 1                        | 0    | 0     | 0 | 0                        | 0    | 1     | 0 | 1                         | 0    | 1     | 0 | 0                         | 0    | 0     | 0 | 4     | 50            |
| 2:45 PM                         | 0                        | 0    | 0     | 0 | 1                        | 0    | 0     | 0 | 0                         | 0    | 0     | 0 | 0                         | 1    | 0     | 0 | 2     | 48            |
| 2:50 PM                         | 0                        | 0    | 0     | 0 | 0                        | 0    | 0     | 0 | 0                         | 0    | 0     | 0 | 0                         | 1    | 0     | 0 | 1     | 44            |
| 2:55 PM                         | 0                        | 0    | 0     | 0 | 0                        | 1    | 1     | 1 | 2                         | 0    | 1     | 0 | 0                         | 0    | 0     | 0 | 6     | 48            |
| 3:00 PM                         | 0                        | 0    | 0     | 0 | 0                        | 0    | 3     | 0 | 1                         | 0    | 0     | 0 | 0                         | 0    | 0     | 0 | 4     | 47            |
| 3:05 PM                         | 1                        | 0    | 0     | 0 | 0                        | 0    | 0     | 0 | 3                         | 1    | 1     | 0 | 0                         | 0    | 0     | 0 | 6     | 48            |
| 3:10 PM                         | 2                        | 0    | 0     | 0 | 0                        | 0    | 1     | 0 | 0                         | 0    | 4     | 0 | 0                         | 0    | 0     | 0 | 7     | 50            |
| 3:15 PM                         | 2                        | 1    | 0     | 0 | 0                        | 0    | 2     | 0 | 1                         | 1    | 3     | 0 | 1                         | 0    | 0     | 0 | 11    | 57            |
| 3:20 PM                         | 2                        | 0    | 0     | 0 | 0                        | 0    | 1     | 0 | 2                         | 0    | 2     | 0 | 0                         | 0    | 0     | 0 | 7     | 58            |
| 3:25 PM                         | 4                        | 0    | 0     | 0 | 0                        | 0    | 2     | 0 | 0                         | 0    | 4     | 0 | 0                         | 0    | 0     | 0 | 10    | 66            |
| 3:30 PM                         | 3                        | 0    | 0     | 0 | 0                        | 0    | 1     | 0 | 2                         | 1    | 4     | 0 | 0                         | 0    | 0     | 0 | 11    | 73            |
| 3:35 PM                         | 4                        | 0    | 0     | 0 | 0                        | 0    | 0     | 0 | 0                         | 0    | 3     | 0 | 0                         | 0    | 0     | 0 | 7     | 76            |
| 3:40 PM                         | 4                        | 0    | 0     | 0 | 0                        | 0    | 1     | 0 | 0                         | 0    | 1     | 0 | 0                         | 0    | 0     | 0 | 6     | 78            |
| 3:45 PM                         | 2                        | 0    | 0     | 0 | 0                        | 0    | 0     | 0 | 0                         | 1    | 1     | 0 | 0                         | 0    | 0     | 0 | 4     | 80            |
| 3:50 PM                         | 3                        | 0    | 0     | 0 | 0                        | 0    | 0     | 0 | 2                         | 0    | 0     | 0 | 0                         | 1    | 0     | 0 | 6     | 85            |
| 3:55 PM                         | 1                        | 0    | 0     | 0 | 0                        | 0    | 0     | 0 | 3                         | 0    | 3     | 0 | 0                         | 0    | 1     | 0 | 8     | 87            |
| 4:00 PM                         | 0                        | 0    | 0     | 0 | 1                        | 0    | 2     | 0 | 1                         | 0    | 1     | 0 | 0                         | 1    | 1     | 0 | 7     | 90            |
| 4:05 PM                         | 0                        | 0    | 0     | 0 | 0                        | 0    | 0     | 0 | 1                         | 0    | 2     | 0 | 0                         | 0    | 0     | 0 | 3     | 87            |
| 4:10 PM                         | 0                        | 0    | 0     | 0 | 0                        | 0    | 0     | 0 | 1                         | 1    | 0     | 0 | 0                         | 0    | 0     | 0 | 2     | 82            |
| 4:15 PM                         | 1                        | 0    | 0     | 0 | 1                        | 0    | 1     | 0 | 2                         | 0    | 2     | 0 | 0                         | 1    | 0     | 0 | 8     | 79            |
| 4:20 PM                         | 1                        | 0    | 0     | 0 | 0                        | 0    | 2     | 0 | 3                         | 1    | 1     | 0 | 0                         | 1    | 0     | 0 | 9     | 81            |
| 4:25 PM                         | 0                        | 0    | 0     | 0 | 0                        | 0    | 2     | 0 | 2                         | 0    | 3     | 0 | 0                         | 0    | 0     | 0 | 7     | 78            |
| 4:30 PM                         | 6                        | 0    | 0     | 0 | 0                        | 0    | 0     | 0 | 1                         | 1    | 7     | 0 | 0                         | 2    | 0     | 0 | 17    | 84            |

**Attachment B**

| 5-Min Count Period Beginning At | Langford Ln (Northbound) |      |       |   | Langford Ln (Southbound) |      |       |   | Ranunculus St (Eastbound) |      |       |   | Ranunculus St (Westbound) |      |       |   | Total | Hourly Totals |
|---------------------------------|--------------------------|------|-------|---|--------------------------|------|-------|---|---------------------------|------|-------|---|---------------------------|------|-------|---|-------|---------------|
|                                 | Left                     | Thru | Right | U | Left                     | Thru | Right | U | Left                      | Thru | Right | U | Left                      | Thru | Right | U |       |               |
| 4:35 PM                         | 7                        | 0    | 0     | 0 | 0                        | 0    | 1     | 0 | 2                         | 1    | 0     | 0 | 0                         | 0    | 0     | 0 | 11    | 88            |
| 4:40 PM                         | 0                        | 0    | 0     | 0 | 0                        | 0    | 2     | 0 | 2                         | 0    | 2     | 0 | 0                         | 0    | 0     | 0 | 6     | 88            |
| 4:45 PM                         | 1                        | 0    | 0     | 0 | 0                        | 0    | 0     | 0 | 1                         | 0    | 2     | 0 | 0                         | 0    | 0     | 0 | 4     | 88            |
| 4:50 PM                         | 0                        | 0    | 0     | 0 | 0                        | 1    | 0     | 0 | 0                         | 0    | 2     | 0 | 0                         | 0    | 0     | 0 | 3     | 85            |
| 4:55 PM                         | 5                        | 0    | 1     | 0 | 0                        | 0    | 3     | 0 | 2                         | 1    | 2     | 0 | 0                         | 0    | 0     | 0 | 14    | 91            |
| 5:00 PM                         | 1                        | 0    | 0     | 0 | 0                        | 0    | 0     | 0 | 0                         | 0    | 0     | 0 | 0                         | 1    | 0     | 0 | 2     | 86            |
| 5:05 PM                         | 4                        | 0    | 0     | 0 | 0                        | 0    | 0     | 0 | 1                         | 1    | 3     | 0 | 0                         | 0    | 0     | 0 | 9     | 92            |
| 5:10 PM                         | 0                        | 0    | 0     | 0 | 0                        | 0    | 0     | 0 | 1                         | 0    | 1     | 0 | 0                         | 0    | 0     | 0 | 2     | 92            |
| 5:15 PM                         | 2                        | 0    | 0     | 0 | 0                        | 0    | 1     | 0 | 0                         | 0    | 1     | 0 | 0                         | 0    | 0     | 0 | 4     | 88            |
| 5:20 PM                         | 0                        | 0    | 0     | 0 | 0                        | 0    | 0     | 0 | 2                         | 0    | 3     | 0 | 0                         | 0    | 0     | 0 | 5     | 84            |
| 5:25 PM                         | 3                        | 0    | 0     | 0 | 0                        | 0    | 1     | 0 | 3                         | 0    | 4     | 0 | 0                         | 0    | 0     | 0 | 11    | 88            |
| 5:30 PM                         | 3                        | 0    | 0     | 0 | 0                        | 0    | 2     | 0 | 0                         | 0    | 3     | 0 | 0                         | 1    | 0     | 0 | 9     | 80            |
| 5:35 PM                         | 4                        | 0    | 0     | 0 | 0                        | 0    | 3     | 0 | 1                         | 0    | 2     | 0 | 0                         | 0    | 0     | 0 | 10    | 79            |
| 5:40 PM                         | 1                        | 0    | 0     | 0 | 0                        | 0    | 2     | 0 | 0                         | 0    | 0     | 0 | 0                         | 0    | 0     | 0 | 3     | 76            |
| 5:45 PM                         | 1                        | 0    | 0     | 0 | 0                        | 0    | 4     | 0 | 1                         | 1    | 3     | 0 | 0                         | 0    | 0     | 0 | 10    | 82            |
| 5:50 PM                         | 4                        | 0    | 0     | 0 | 0                        | 0    | 0     | 0 | 0                         | 0    | 0     | 0 | 0                         | 0    | 0     | 0 | 4     | 83            |
| 5:55 PM                         | 0                        | 0    | 0     | 0 | 0                        | 0    | 1     | 0 | 2                         | 0    | 0     | 0 | 0                         | 0    | 0     | 0 | 3     | 72            |
| 6:00 PM                         | 1                        | 0    | 0     | 0 | 0                        | 0    | 0     | 0 | 1                         | 0    | 2     | 0 | 0                         | 0    | 0     | 0 | 4     | 74            |
| 6:05 PM                         | 0                        | 0    | 0     | 0 | 1                        | 0    | 0     | 0 | 3                         | 0    | 3     | 0 | 0                         | 0    | 0     | 0 | 7     | 72            |
| 6:10 PM                         | 0                        | 0    | 0     | 0 | 0                        | 0    | 0     | 0 | 1                         | 0    | 0     | 0 | 0                         | 1    | 0     | 0 | 2     | 72            |
| 6:15 PM                         | 1                        | 0    | 0     | 0 | 0                        | 0    | 1     | 0 | 0                         | 1    | 1     | 0 | 0                         | 1    | 0     | 0 | 5     | 73            |
| 6:20 PM                         | 1                        | 0    | 0     | 0 | 0                        | 0    | 0     | 0 | 1                         | 0    | 0     | 0 | 0                         | 0    | 0     | 0 | 2     | 70            |
| 6:25 PM                         | 0                        | 0    | 0     | 0 | 0                        | 0    | 2     | 0 | 1                         | 0    | 0     | 0 | 0                         | 0    | 0     | 0 | 3     | 62            |
| 6:30 PM                         | 0                        | 0    | 0     | 0 | 0                        | 0    | 2     | 0 | 2                         | 0    | 1     | 0 | 0                         | 0    | 0     | 0 | 5     | 58            |
| 6:35 PM                         | 1                        | 0    | 0     | 0 | 0                        | 0    | 0     | 0 | 4                         | 0    | 0     | 0 | 0                         | 1    | 0     | 0 | 6     | 54            |
| 6:40 PM                         | 1                        | 0    | 0     | 0 | 0                        | 0    | 1     | 0 | 2                         | 1    | 1     | 0 | 0                         | 0    | 0     | 0 | 6     | 57            |
| 6:45 PM                         | 0                        | 0    | 0     | 0 | 0                        | 0    | 2     | 0 | 2                         | 0    | 3     | 0 | 0                         | 0    | 0     | 0 | 7     | 54            |
| 6:50 PM                         | 3                        | 0    | 0     | 0 | 0                        | 0    | 1     | 0 | 0                         | 3    | 2     | 0 | 0                         | 0    | 0     | 0 | 9     | 59            |
| 6:55 PM                         | 0                        | 0    | 0     | 0 | 0                        | 0    | 1     | 0 | 3                         | 0    | 0     | 0 | 0                         | 0    | 0     | 0 | 4     | 60            |
| 7:00 PM                         | 0                        | 0    | 0     | 0 | 0                        | 0    | 0     | 0 | 0                         | 0    | 0     | 0 | 0                         | 0    | 0     | 0 | 0     | 56            |
| 7:05 PM                         | 1                        | 0    | 0     | 0 | 0                        | 0    | 1     | 0 | 1                         | 0    | 0     | 0 | 0                         | 0    | 0     | 0 | 3     | 52            |
| 7:10 PM                         | 0                        | 0    | 0     | 0 | 0                        | 0    | 1     | 0 | 1                         | 0    | 1     | 0 | 0                         | 0    | 0     | 0 | 3     | 53            |
| 7:15 PM                         | 2                        | 0    | 0     | 0 | 0                        | 0    | 0     | 0 | 0                         | 0    | 2     | 0 | 0                         | 0    | 0     | 0 | 4     | 52            |
| 7:20 PM                         | 0                        | 0    | 0     | 0 | 0                        | 0    | 0     | 0 | 5                         | 0    | 0     | 0 | 0                         | 0    | 0     | 0 | 5     | 55            |
| 7:25 PM                         | 1                        | 0    | 0     | 0 | 0                        | 0    | 0     | 0 | 0                         | 1    | 2     | 0 | 0                         | 1    | 0     | 0 | 5     | 57            |
| 7:30 PM                         | 2                        | 0    | 0     | 0 | 0                        | 0    | 1     | 0 | 0                         | 0    | 1     | 0 | 0                         | 0    | 0     | 0 | 4     | 56            |
| 7:35 PM                         | 0                        | 0    | 0     | 0 | 0                        | 0    | 0     | 0 | 1                         | 0    | 1     | 0 | 0                         | 0    | 0     | 0 | 2     | 52            |
| 7:40 PM                         | 0                        | 0    | 0     | 0 | 1                        | 0    | 0     | 0 | 1                         | 0    | 0     | 0 | 0                         | 0    | 0     | 0 | 2     | 48            |
| 7:45 PM                         | 0                        | 0    | 0     | 0 | 0                        | 0    | 1     | 0 | 0                         | 0    | 2     | 0 | 0                         | 0    | 0     | 0 | 3     | 44            |
| 7:50 PM                         | 0                        | 0    | 0     | 0 | 0                        | 0    | 0     | 0 | 1                         | 0    | 0     | 0 | 0                         | 0    | 0     | 0 | 1     | 36            |
| 7:55 PM                         | 1                        | 0    | 0     | 0 | 0                        | 0    | 1     | 0 | 1                         | 0    | 1     | 0 | 0                         | 0    | 0     | 0 | 4     | 36            |
| 8:00 PM                         | 0                        | 0    | 0     | 0 | 0                        | 0    | 1     | 0 | 0                         | 0    | 0     | 0 | 0                         | 0    | 0     | 0 | 1     | 37            |
| 8:05 PM                         | 2                        | 0    | 0     | 0 | 0                        | 0    | 1     | 0 | 2                         | 0    | 0     | 0 | 0                         | 0    | 0     | 0 | 5     | 39            |
| 8:10 PM                         | 0                        | 0    | 0     | 0 | 0                        | 0    | 1     | 0 | 2                         | 0    | 0     | 0 | 0                         | 0    | 0     | 0 | 3     | 39            |
| 8:15 PM                         | 0                        | 0    | 0     | 0 | 0                        | 0    | 0     | 0 | 1                         | 1    | 1     | 0 | 0                         | 0    | 0     | 0 | 3     | 38            |
| 8:20 PM                         | 1                        | 0    | 0     | 0 | 0                        | 0    | 1     | 0 | 1                         | 0    | 0     | 0 | 0                         | 0    | 0     | 0 | 3     | 36            |
| 8:25 PM                         | 0                        | 0    | 0     | 0 | 0                        | 0    | 0     | 0 | 0                         | 0    | 0     | 0 | 0                         | 0    | 0     | 0 | 0     | 31            |
| 8:30 PM                         | 0                        | 0    | 0     | 0 | 0                        | 0    | 0     | 0 | 0                         | 0    | 0     | 0 | 0                         | 0    | 0     | 0 | 0     | 27            |
| 8:35 PM                         | 1                        | 0    | 0     | 0 | 0                        | 0    | 0     | 0 | 1                         | 0    | 1     | 0 | 0                         | 0    | 0     | 0 | 3     | 28            |
| 8:40 PM                         | 0                        | 0    | 0     | 0 | 0                        | 0    | 0     | 0 | 0                         | 0    | 1     | 0 | 0                         | 0    | 0     | 0 | 1     | 27            |
| 8:45 PM                         | 0                        | 0    | 0     | 0 | 0                        | 0    | 0     | 0 | 1                         | 0    | 0     | 0 | 0                         | 0    | 0     | 0 | 1     | 25            |
| 8:50 PM                         | 0                        | 0    | 0     | 0 | 0                        | 0    | 0     | 0 | 0                         | 0    | 0     | 0 | 0                         | 0    | 0     | 0 | 0     | 24            |
| 8:55 PM                         | 0                        | 0    | 0     | 0 | 0                        | 0    | 0     | 0 | 0                         | 0    | 0     | 0 | 0                         | 0    | 0     | 0 | 0     | 20            |
| 9:00 PM                         | 0                        | 0    | 0     | 0 | 0                        | 0    | 0     | 0 | 0                         | 0    | 1     | 0 | 0                         | 0    | 0     | 0 | 1     | 20            |
| 9:05 PM                         | 0                        | 0    | 0     | 0 | 0                        | 0    | 0     | 0 | 1                         | 0    | 1     | 0 | 0                         | 0    | 0     | 0 | 2     | 17            |
| 9:10 PM                         | 0                        | 0    | 0     | 0 | 0                        | 0    | 0     | 0 | 2                         | 0    | 1     | 0 | 0                         | 0    | 0     | 0 | 3     | 17            |
| 9:15 PM                         | 0                        | 0    | 0     | 0 | 0                        | 0    | 0     | 0 | 1                         | 0    | 0     | 0 | 0                         | 0    | 0     | 0 | 1     | 15            |
| 9:20 PM                         | 0                        | 0    | 0     | 0 | 0                        | 0    | 0     | 0 | 2                         | 0    | 0     | 0 | 0                         | 0    | 0     | 0 | 2     | 14            |
| 9:25 PM                         | 0                        | 0    | 0     | 0 | 0                        | 0    | 0     | 0 | 0                         | 0    | 0     | 0 | 0                         | 0    | 0     | 0 | 0     | 14            |
| 9:30 PM                         | 0                        | 0    | 0     | 0 | 0                        | 0    | 0     | 0 | 0                         | 0    | 2     | 0 | 0                         | 0    | 0     | 0 | 2     | 16            |
| 9:35 PM                         | 0                        | 0    | 0     | 0 | 0                        | 0    | 0     | 0 | 0                         | 0    | 0     | 0 | 0                         | 0    | 0     | 0 | 0     | 13            |
| 9:40 PM                         | 0                        | 0    | 0     | 0 | 0                        | 0    | 0     | 0 | 1                         | 0    | 0     | 0 | 0                         | 0    | 0     | 0 | 1     | 13            |
| 9:45 PM                         | 0                        | 0    | 0     | 0 | 0                        | 0    | 0     | 0 | 0                         | 0    | 0     | 0 | 0                         | 0    | 0     | 0 | 0     | 12            |
| 9:50 PM                         | 0                        | 0    | 0     | 0 | 0                        | 0    | 0     | 0 | 0                         | 0    | 0     | 0 | 0                         | 0    | 0     | 0 | 0     | 12            |
| 9:55 PM                         | 0                        | 0    | 0     | 0 | 0                        | 0    | 0     | 0 | 1                         | 0    | 1     | 0 | 0                         | 0    | 0     | 0 | 2     | 14            |
| Peak 15-Min Flowrates           | Northbound               |      |       |   | Southbound               |      |       |   | Eastbound                 |      |       |   | Westbound                 |      |       |   | Total |               |
|                                 | Left                     | Thru | Right | U | Left                     | Thru | Right | U | Left                      | Thru | Right | U | Left                      | Thru | Right | U |       |               |
| All Vehicles                    | 32                       | 0    | 0     | 0 | 0                        | 0    | 28    | 0 | 20                        | 4    | 32    | 0 | 0                         | 8    | 0     | 0 | 124   |               |
| Heavy Trucks                    | 0                        | 0    | 0     |   | 0                        | 0    | 0     |   | 0                         | 0    | 0     |   | 0                         | 0    | 0     |   | 0     |               |
| Buses                           |                          |      |       |   |                          |      |       |   |                           |      |       |   |                           |      |       |   |       |               |
| Pedestrians                     |                          | 0    |       |   |                          | 0    |       |   |                           | 0    |       |   |                           | 0    |       |   | 0     |               |
| Bicycles                        | 0                        | 0    | 0     |   | 0                        | 0    | 0     |   | 0                         | 0    | 0     |   | 0                         | 0    | 0     |   | 0     |               |
| Scoters                         |                          |      |       |   |                          |      |       |   |                           |      |       |   |                           |      |       |   |       |               |
| <i>Comments:</i>                |                          |      |       |   |                          |      |       |   |                           |      |       |   |                           |      |       |   |       |               |

Report generated on 4/25/2025 4:03 PM

SOURCE: Quality Counts, LLC (<http://www.qualitycounts.net>) 1-877-580-2212

LOCATION: Scarlet Maple Dr -- Smoke Tree Dr  
 CITY/STATE: Ladera Ranch, CA

QC JOB #: 16966465  
 DATE: Wed, Apr 16 2025

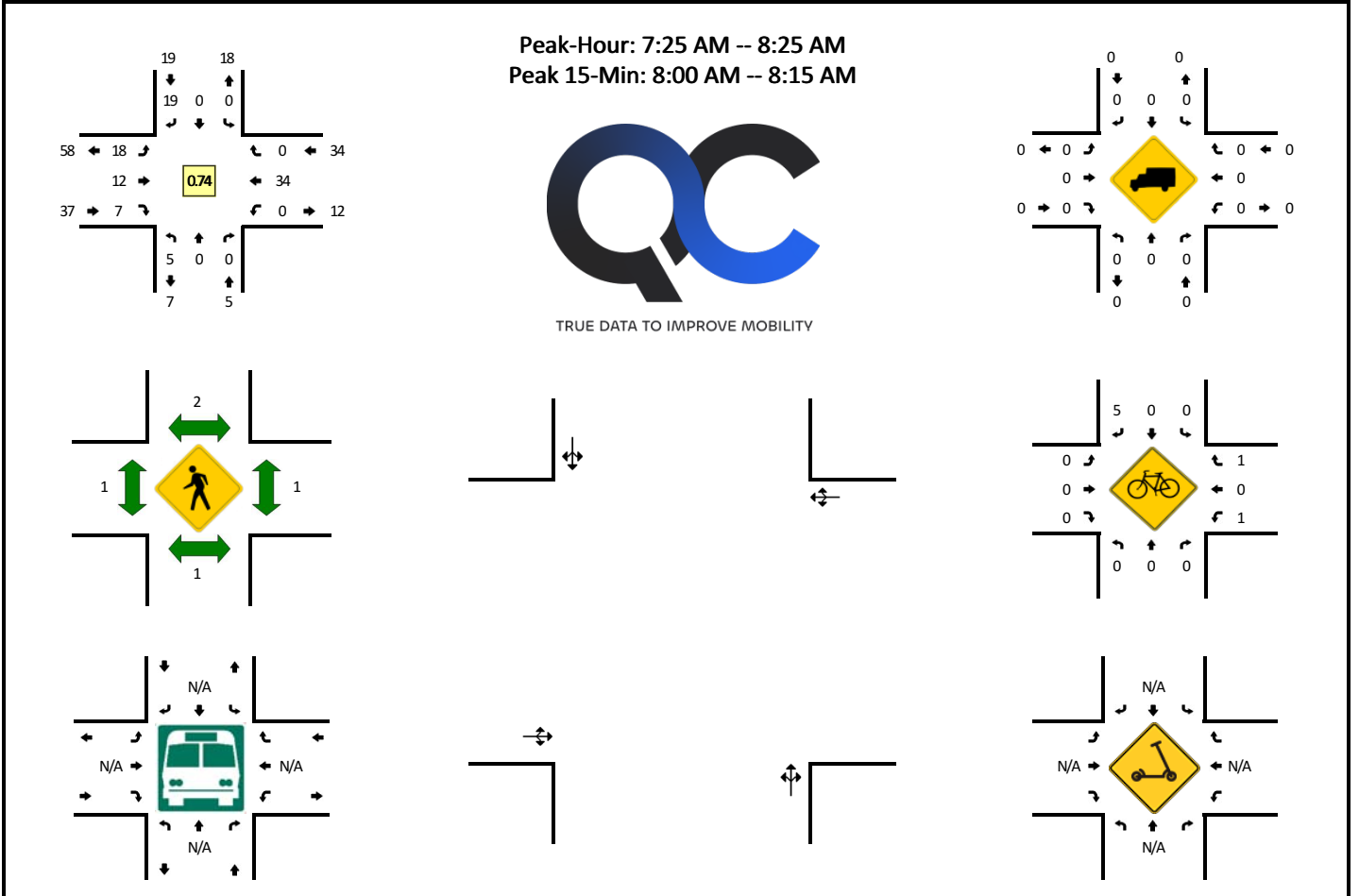

| 5-Min Count Period Beginning At | Scarlet Maple Dr (Northbound) |      |       |   | Scarlet Maple Dr (Southbound) |      |       |   | Smoke Tree Dr (Eastbound) |      |       |   | Smoke Tree Dr (Westbound) |      |       |   | Total | Hourly Totals |
|---------------------------------|-------------------------------|------|-------|---|-------------------------------|------|-------|---|---------------------------|------|-------|---|---------------------------|------|-------|---|-------|---------------|
|                                 | Left                          | Thru | Right | U | Left                          | Thru | Right | U | Left                      | Thru | Right | U | Left                      | Thru | Right | U |       |               |
| 6:00 AM                         | 0                             | 0    | 0     | 0 | 0                             | 0    | 1     | 0 | 0                         | 0    | 0     | 0 | 0                         | 0    | 0     | 0 | 1     |               |
| 6:05 AM                         | 0                             | 0    | 0     | 0 | 0                             | 0    | 0     | 0 | 0                         | 0    | 0     | 0 | 0                         | 1    | 0     | 0 | 1     |               |
| 6:10 AM                         | 0                             | 0    | 0     | 0 | 0                             | 0    | 1     | 0 | 1                         | 0    | 0     | 0 | 0                         | 0    | 0     | 0 | 2     |               |
| 6:15 AM                         | 1                             | 0    | 0     | 0 | 0                             | 0    | 1     | 0 | 0                         | 0    | 0     | 0 | 0                         | 0    | 0     | 0 | 2     |               |
| 6:20 AM                         | 0                             | 0    | 0     | 0 | 0                             | 0    | 1     | 0 | 0                         | 0    | 0     | 0 | 0                         | 0    | 0     | 0 | 1     |               |
| 6:25 AM                         | 0                             | 0    | 1     | 0 | 0                             | 0    | 0     | 0 | 0                         | 0    | 1     | 0 | 0                         | 2    | 0     | 0 | 4     |               |
| 6:30 AM                         | 0                             | 0    | 0     | 0 | 0                             | 0    | 1     | 0 | 0                         | 0    | 0     | 0 | 0                         | 2    | 1     | 0 | 4     |               |
| 6:35 AM                         | 1                             | 0    | 0     | 0 | 0                             | 0    | 0     | 0 | 0                         | 0    | 0     | 0 | 0                         | 0    | 0     | 0 | 1     |               |
| 6:40 AM                         | 0                             | 0    | 0     | 0 | 0                             | 0    | 0     | 0 | 0                         | 0    | 0     | 0 | 0                         | 0    | 0     | 0 | 0     |               |
| 6:45 AM                         | 0                             | 0    | 0     | 0 | 0                             | 0    | 2     | 0 | 0                         | 0    | 0     | 0 | 0                         | 5    | 0     | 0 | 7     |               |
| 6:50 AM                         | 0                             | 0    | 0     | 0 | 0                             | 0    | 1     | 0 | 0                         | 1    | 0     | 0 | 0                         | 2    | 0     | 0 | 4     |               |
| 6:55 AM                         | 0                             | 0    | 0     | 0 | 0                             | 0    | 0     | 0 | 0                         | 1    | 0     | 0 | 0                         | 2    | 0     | 0 | 3     | 30            |
| 7:00 AM                         | 0                             | 0    | 0     | 0 | 0                             | 0    | 0     | 0 | 0                         | 0    | 0     | 0 | 0                         | 0    | 0     | 0 | 0     | 29            |
| 7:05 AM                         | 0                             | 0    | 0     | 0 | 0                             | 0    | 1     | 0 | 0                         | 0    | 0     | 0 | 0                         | 0    | 0     | 0 | 1     | 29            |
| 7:10 AM                         | 0                             | 0    | 0     | 0 | 0                             | 0    | 0     | 0 | 0                         | 1    | 0     | 0 | 0                         | 3    | 0     | 0 | 4     | 31            |
| 7:15 AM                         | 0                             | 0    | 0     | 0 | 0                             | 0    | 0     | 0 | 1                         | 1    | 0     | 0 | 0                         | 0    | 0     | 0 | 2     | 31            |
| 7:20 AM                         | 0                             | 0    | 0     | 0 | 0                             | 0    | 1     | 0 | 1                         | 1    | 0     | 0 | 0                         | 3    | 0     | 0 | 6     | 36            |
| 7:25 AM                         | 2                             | 0    | 0     | 0 | 0                             | 0    | 2     | 0 | 0                         | 0    | 0     | 0 | 0                         | 0    | 0     | 0 | 4     | 36            |
| 7:30 AM                         | 1                             | 0    | 0     | 0 | 0                             | 0    | 1     | 0 | 0                         | 0    | 0     | 0 | 0                         | 3    | 0     | 0 | 5     | 37            |
| 7:35 AM                         | 1                             | 0    | 0     | 0 | 0                             | 0    | 0     | 0 | 0                         | 2    | 1     | 0 | 0                         | 2    | 0     | 0 | 7     | 43            |
| 7:40 AM                         | 0                             | 0    | 0     | 0 | 0                             | 0    | 2     | 0 | 0                         | 0    | 0     | 0 | 0                         | 3    | 0     | 0 | 5     | 48            |
| 7:45 AM                         | 0                             | 0    | 0     | 0 | 0                             | 0    | 3     | 0 | 2                         | 0    | 2     | 0 | 0                         | 3    | 0     | 0 | 10    | 51            |
| 7:50 AM                         | 1                             | 0    | 0     | 0 | 0                             | 0    | 4     | 0 | 1                         | 0    | 1     | 0 | 0                         | 5    | 0     | 0 | 12    | 59            |
| 7:55 AM                         | 0                             | 0    | 0     | 0 | 0                             | 0    | 1     | 0 | 2                         | 1    | 0     | 0 | 0                         | 3    | 0     | 0 | 7     | 63            |
| 8:00 AM                         | 0                             | 0    | 0     | 0 | 0                             | 0    | 2     | 0 | 5                         | 1    | 1     | 0 | 0                         | 3    | 0     | 0 | 12    | 75            |
| 8:05 AM                         | 0                             | 0    | 0     | 0 | 0                             | 0    | 3     | 0 | 0                         | 3    | 0     | 0 | 0                         | 3    | 0     | 0 | 9     | 83            |
| 8:10 AM                         | 0                             | 0    | 0     | 0 | 0                             | 0    | 0     | 0 | 3                         | 2    | 0     | 0 | 0                         | 6    | 0     | 0 | 11    | 90            |
| 8:15 AM                         | 0                             | 0    | 0     | 0 | 0                             | 0    | 0     | 0 | 2                         | 1    | 2     | 0 | 0                         | 1    | 0     | 0 | 6     | 94            |
| 8:20 AM                         | 0                             | 0    | 0     | 0 | 0                             | 0    | 0     | 0 | 3                         | 2    | 0     | 0 | 0                         | 2    | 0     | 0 | 7     | 95            |
| 8:25 AM                         | 1                             | 0    | 0     | 0 | 0                             | 0    | 1     | 0 | 1                         | 0    | 0     | 0 | 0                         | 1    | 0     | 0 | 4     | 95            |
| 8:30 AM                         | 0                             | 0    | 0     | 0 | 0                             | 0    | 1     | 0 | 0                         | 1    | 0     | 0 | 0                         | 2    | 0     | 0 | 4     | 94            |
| 8:35 AM                         | 0                             | 0    | 0     | 0 | 0                             | 0    | 0     | 0 | 0                         | 0    | 0     | 0 | 0                         | 1    | 0     | 0 | 1     | 88            |
| 8:40 AM                         | 0                             | 0    | 0     | 0 | 0                             | 0    | 0     | 0 | 0                         | 0    | 0     | 0 | 0                         | 1    | 0     | 0 | 1     | 84            |
| 8:45 AM                         | 0                             | 0    | 0     | 0 | 0                             | 0    | 0     | 0 | 1                         | 2    | 2     | 0 | 0                         | 1    | 0     | 0 | 6     | 80            |
| 8:50 AM                         | 0                             | 0    | 0     | 0 | 0                             | 0    | 2     | 0 | 0                         | 1    | 0     | 0 | 0                         | 2    | 0     | 0 | 5     | 73            |
| 8:55 AM                         | 0                             | 0    | 0     | 0 | 0                             | 0    | 1     | 0 | 0                         | 0    | 0     | 0 | 0                         | 1    | 0     | 0 | 2     | 68            |
| 9:00 AM                         | 0                             | 0    | 0     | 0 | 0                             | 0    | 0     | 0 | 2                         | 0    | 0     | 0 | 0                         | 0    | 0     | 0 | 2     | 58            |
| 9:05 AM                         | 0                             | 0    | 0     | 0 | 0                             | 0    | 0     | 0 | 0                         | 0    | 0     | 0 | 0                         | 2    | 0     | 0 | 2     | 51            |

**Attachment B**

| 5-Min Count<br>Period<br>Beginning At | Scarlet Maple Dr<br>(Northbound) |      |       |   | Scarlet Maple Dr<br>(Southbound) |      |       |   | Smoke Tree Dr<br>(Eastbound) |      |       |   | Smoke Tree Dr<br>(Westbound) |      |       |   | Total | Hourly<br>Totals |
|---------------------------------------|----------------------------------|------|-------|---|----------------------------------|------|-------|---|------------------------------|------|-------|---|------------------------------|------|-------|---|-------|------------------|
|                                       | Left                             | Thru | Right | U | Left                             | Thru | Right | U | Left                         | Thru | Right | U | Left                         | Thru | Right | U |       |                  |
| 9:10 AM                               | 0                                | 0    | 0     | 0 | 0                                | 0    | 4     | 0 | 0                            | 0    | 1     | 0 | 0                            | 0    | 0     | 0 | 5     | 45               |
| 9:15 AM                               | 1                                | 0    | 0     | 0 | 0                                | 0    | 0     | 0 | 0                            | 1    | 1     | 0 | 0                            | 0    | 0     | 0 | 3     | 42               |
| 9:20 AM                               | 3                                | 0    | 0     | 0 | 0                                | 0    | 1     | 0 | 1                            | 0    | 0     | 0 | 0                            | 0    | 0     | 0 | 5     | 40               |
| 9:25 AM                               | 0                                | 0    | 0     | 0 | 0                                | 0    | 0     | 0 | 1                            | 1    | 0     | 0 | 0                            | 1    | 0     | 0 | 3     | 39               |
| 9:30 AM                               | 0                                | 0    | 0     | 0 | 0                                | 0    | 2     | 0 | 3                            | 1    | 0     | 0 | 0                            | 0    | 0     | 0 | 6     | 41               |
| 9:35 AM                               | 0                                | 0    | 0     | 0 | 0                                | 0    | 0     | 0 | 0                            | 0    | 0     | 0 | 0                            | 1    | 0     | 0 | 1     | 41               |
| 9:40 AM                               | 0                                | 0    | 0     | 0 | 0                                | 0    | 3     | 0 | 1                            | 0    | 0     | 0 | 0                            | 0    | 0     | 0 | 4     | 44               |
| 9:45 AM                               | 0                                | 0    | 0     | 0 | 0                                | 0    | 0     | 0 | 1                            | 0    | 0     | 0 | 0                            | 2    | 0     | 0 | 3     | 41               |
| 9:50 AM                               | 0                                | 0    | 0     | 0 | 0                                | 0    | 0     | 0 | 0                            | 1    | 1     | 0 | 0                            | 3    | 0     | 0 | 5     | 41               |
| 9:55 AM                               | 0                                | 0    | 0     | 0 | 0                                | 0    | 3     | 0 | 0                            | 1    | 0     | 0 | 0                            | 1    | 0     | 0 | 5     | 44               |
| 10:00 AM                              | 2                                | 0    | 0     | 0 | 0                                | 0    | 1     | 0 | 1                            | 1    | 0     | 0 | 0                            | 1    | 0     | 0 | 6     | 48               |
| 10:05 AM                              | 0                                | 0    | 0     | 0 | 0                                | 0    | 0     | 0 | 0                            | 0    | 1     | 0 | 0                            | 0    | 0     | 0 | 1     | 47               |
| 10:10 AM                              | 0                                | 0    | 0     | 0 | 0                                | 0    | 0     | 0 | 0                            | 2    | 0     | 0 | 0                            | 1    | 0     | 0 | 3     | 45               |
| 10:15 AM                              | 1                                | 0    | 0     | 0 | 0                                | 0    | 0     | 0 | 1                            | 0    | 0     | 0 | 0                            | 1    | 0     | 0 | 3     | 45               |
| 10:20 AM                              | 0                                | 0    | 0     | 0 | 0                                | 0    | 2     | 0 | 0                            | 0    | 0     | 0 | 0                            | 1    | 0     | 0 | 3     | 43               |
| 10:25 AM                              | 1                                | 0    | 0     | 0 | 0                                | 0    | 0     | 0 | 0                            | 2    | 0     | 0 | 1                            | 1    | 1     | 0 | 6     | 46               |
| 10:30 AM                              | 1                                | 0    | 0     | 0 | 0                                | 0    | 1     | 0 | 0                            | 1    | 0     | 0 | 0                            | 1    | 0     | 0 | 4     | 44               |
| 10:35 AM                              | 0                                | 0    | 0     | 0 | 0                                | 0    | 1     | 0 | 1                            | 3    | 0     | 0 | 0                            | 2    | 0     | 0 | 7     | 50               |
| 10:40 AM                              | 0                                | 0    | 0     | 0 | 0                                | 0    | 1     | 0 | 0                            | 0    | 0     | 0 | 0                            | 0    | 0     | 0 | 1     | 47               |
| 10:45 AM                              | 1                                | 0    | 0     | 0 | 0                                | 0    | 0     | 0 | 1                            | 2    | 0     | 0 | 0                            | 1    | 0     | 0 | 5     | 49               |
| 10:50 AM                              | 0                                | 0    | 0     | 0 | 1                                | 0    | 0     | 0 | 2                            | 2    | 0     | 0 | 0                            | 2    | 0     | 0 | 7     | 51               |
| 10:55 AM                              | 0                                | 0    | 0     | 0 | 0                                | 0    | 1     | 0 | 0                            | 3    | 0     | 0 | 0                            | 2    | 0     | 0 | 6     | 52               |
| 11:00 AM                              | 0                                | 0    | 0     | 0 | 0                                | 0    | 1     | 0 | 1                            | 0    | 0     | 0 | 0                            | 1    | 0     | 0 | 3     | 49               |
| 11:05 AM                              | 0                                | 0    | 0     | 0 | 0                                | 0    | 0     | 0 | 0                            | 0    | 1     | 0 | 0                            | 1    | 0     | 0 | 2     | 50               |
| 11:10 AM                              | 1                                | 0    | 0     | 0 | 0                                | 0    | 1     | 0 | 0                            | 1    | 0     | 0 | 0                            | 1    | 0     | 0 | 4     | 51               |
| 11:15 AM                              | 1                                | 0    | 0     | 0 | 0                                | 0    | 0     | 0 | 0                            | 0    | 1     | 0 | 0                            | 1    | 0     | 0 | 3     | 51               |
| 11:20 AM                              | 0                                | 0    | 0     | 0 | 0                                | 0    | 0     | 0 | 0                            | 0    | 1     | 0 | 0                            | 0    | 0     | 0 | 1     | 49               |
| 11:25 AM                              | 1                                | 0    | 1     | 0 | 0                                | 0    | 0     | 0 | 0                            | 1    | 1     | 0 | 0                            | 0    | 0     | 0 | 4     | 47               |
| 11:30 AM                              | 3                                | 0    | 0     | 0 | 0                                | 0    | 1     | 0 | 0                            | 0    | 0     | 0 | 1                            | 2    | 0     | 0 | 7     | 50               |
| 11:35 AM                              | 1                                | 0    | 0     | 0 | 0                                | 0    | 0     | 0 | 1                            | 1    | 0     | 0 | 0                            | 0    | 0     | 0 | 3     | 46               |
| 11:40 AM                              | 0                                | 0    | 0     | 0 | 0                                | 0    | 1     | 0 | 1                            | 1    | 0     | 0 | 0                            | 2    | 0     | 0 | 5     | 50               |
| 11:45 AM                              | 0                                | 0    | 0     | 0 | 0                                | 0    | 1     | 0 | 1                            | 2    | 0     | 0 | 0                            | 1    | 0     | 0 | 5     | 50               |
| 11:50 AM                              | 0                                | 0    | 0     | 0 | 0                                | 0    | 1     | 0 | 0                            | 1    | 0     | 0 | 0                            | 2    | 0     | 0 | 4     | 47               |
| 11:55 AM                              | 0                                | 0    | 0     | 0 | 0                                | 0    | 0     | 0 | 1                            | 2    | 0     | 0 | 0                            | 1    | 0     | 0 | 4     | 45               |
| 12:00 PM                              | 0                                | 0    | 0     | 0 | 0                                | 0    | 2     | 0 | 1                            | 2    | 0     | 0 | 0                            | 0    | 0     | 0 | 5     | 47               |
| 12:05 PM                              | 0                                | 0    | 1     | 0 | 0                                | 0    | 0     | 0 | 1                            | 1    | 2     | 0 | 0                            | 1    | 0     | 0 | 6     | 51               |
| 12:10 PM                              | 0                                | 0    | 0     | 0 | 0                                | 0    | 0     | 0 | 0                            | 2    | 0     | 0 | 0                            | 1    | 0     | 0 | 3     | 50               |
| 12:15 PM                              | 1                                | 0    | 0     | 0 | 0                                | 0    | 0     | 0 | 0                            | 2    | 1     | 0 | 0                            | 0    | 0     | 0 | 4     | 51               |
| 12:20 PM                              | 0                                | 0    | 0     | 0 | 0                                | 0    | 3     | 0 | 1                            | 0    | 1     | 0 | 0                            | 1    | 2     | 0 | 8     | 58               |
| 12:25 PM                              | 0                                | 1    | 0     | 0 | 0                                | 0    | 1     | 0 | 0                            | 0    | 1     | 0 | 0                            | 1    | 0     | 0 | 4     | 58               |
| 12:30 PM                              | 0                                | 0    | 0     | 0 | 0                                | 0    | 0     | 1 | 1                            | 1    | 0     | 0 | 0                            | 1    | 1     | 0 | 5     | 56               |
| 12:35 PM                              | 0                                | 0    | 0     | 0 | 0                                | 0    | 0     | 0 | 2                            | 0    | 1     | 0 | 0                            | 0    | 0     | 0 | 3     | 56               |
| 12:40 PM                              | 0                                | 0    | 0     | 0 | 1                                | 0    | 0     | 0 | 1                            | 0    | 1     | 0 | 0                            | 1    | 0     | 0 | 4     | 55               |
| 12:45 PM                              | 0                                | 0    | 0     | 0 | 0                                | 0    | 3     | 0 | 3                            | 1    | 0     | 0 | 0                            | 1    | 0     | 0 | 8     | 58               |
| 12:50 PM                              | 0                                | 0    | 0     | 0 | 0                                | 0    | 0     | 0 | 1                            | 1    | 0     | 0 | 1                            | 2    | 0     | 0 | 5     | 59               |
| 12:55 PM                              | 1                                | 1    | 0     | 0 | 0                                | 0    | 0     | 0 | 0                            | 2    | 2     | 0 | 0                            | 3    | 0     | 0 | 9     | 64               |
| 1:00 PM                               | 1                                | 0    | 0     | 0 | 0                                | 0    | 3     | 0 | 0                            | 0    | 1     | 0 | 0                            | 2    | 0     | 0 | 7     | 66               |
| 1:05 PM                               | 0                                | 0    | 0     | 0 | 0                                | 0    | 1     | 0 | 0                            | 1    | 0     | 0 | 0                            | 1    | 0     | 0 | 3     | 63               |
| 1:10 PM                               | 0                                | 0    | 0     | 0 | 1                                | 0    | 3     | 0 | 0                            | 1    | 0     | 0 | 0                            | 2    | 0     | 0 | 7     | 67               |
| 1:15 PM                               | 1                                | 0    | 0     | 0 | 0                                | 0    | 3     | 0 | 3                            | 2    | 0     | 0 | 0                            | 0    | 0     | 0 | 9     | 72               |
| 1:20 PM                               | 0                                | 0    | 0     | 0 | 0                                | 0    | 0     | 0 | 2                            | 1    | 1     | 0 | 0                            | 1    | 0     | 0 | 5     | 69               |
| 1:25 PM                               | 1                                | 0    | 0     | 0 | 0                                | 0    | 1     | 0 | 4                            | 2    | 0     | 0 | 0                            | 0    | 0     | 0 | 8     | 73               |
| 1:30 PM                               | 0                                | 0    | 0     | 0 | 0                                | 0    | 2     | 0 | 1                            | 2    | 2     | 0 | 0                            | 0    | 0     | 0 | 7     | 75               |
| 1:35 PM                               | 1                                | 0    | 0     | 0 | 0                                | 0    | 1     | 0 | 0                            | 3    | 0     | 0 | 0                            | 1    | 0     | 0 | 6     | 78               |
| 1:40 PM                               | 0                                | 0    | 0     | 0 | 0                                | 0    | 1     | 0 | 0                            | 1    | 0     | 0 | 0                            | 0    | 1     | 0 | 3     | 77               |
| 1:45 PM                               | 1                                | 0    | 0     | 0 | 0                                | 0    | 0     | 0 | 0                            | 1    | 1     | 0 | 0                            | 4    | 0     | 0 | 7     | 76               |
| 1:50 PM                               | 0                                | 0    | 0     | 0 | 0                                | 0    | 0     | 0 | 1                            | 3    | 0     | 0 | 0                            | 1    | 0     | 0 | 5     | 76               |
| 1:55 PM                               | 0                                | 0    | 0     | 0 | 0                                | 0    | 0     | 0 | 2                            | 0    | 0     | 0 | 0                            | 1    | 0     | 0 | 3     | 70               |
| 2:00 PM                               | 0                                | 0    | 0     | 0 | 0                                | 0    | 1     | 0 | 0                            | 0    | 0     | 0 | 0                            | 0    | 0     | 0 | 1     | 64               |
| 2:05 PM                               | 0                                | 0    | 0     | 0 | 0                                | 0    | 1     | 0 | 0                            | 0    | 1     | 0 | 0                            | 0    | 0     | 0 | 2     | 63               |
| 2:10 PM                               | 0                                | 0    | 0     | 0 | 0                                | 0    | 0     | 0 | 0                            | 2    | 1     | 0 | 0                            | 1    | 0     | 0 | 4     | 60               |
| 2:15 PM                               | 0                                | 0    | 0     | 0 | 0                                | 0    | 1     | 0 | 0                            | 1    | 1     | 0 | 0                            | 0    | 0     | 0 | 3     | 54               |
| 2:20 PM                               | 0                                | 0    | 0     | 0 | 0                                | 0    | 1     | 0 | 0                            | 2    | 1     | 0 | 0                            | 0    | 0     | 0 | 4     | 53               |
| 2:25 PM                               | 1                                | 1    | 0     | 0 | 0                                | 0    | 1     | 0 | 1                            | 1    | 1     | 0 | 0                            | 2    | 0     | 0 | 8     | 53               |
| 2:30 PM                               | 1                                | 0    | 0     | 0 | 1                                | 0    | 0     | 0 | 1                            | 3    | 0     | 0 | 0                            | 1    | 0     | 0 | 7     | 53               |
| 2:35 PM                               | 0                                | 0    | 0     | 0 | 0                                | 0    | 0     | 0 | 2                            | 1    | 0     | 0 | 0                            | 4    | 0     | 0 | 7     | 54               |
| 2:40 PM                               | 0                                | 0    | 0     | 0 | 0                                | 0    | 2     | 0 | 0                            | 0    | 0     | 0 | 0                            | 3    | 0     | 0 | 5     | 56               |
| 2:45 PM                               | 0                                | 0    | 0     | 0 | 0                                | 0    | 1     | 0 | 1                            | 4    | 0     | 0 | 0                            | 4    | 0     | 0 | 10    | 59               |
| 2:50 PM                               | 0                                | 0    | 0     | 0 | 0                                | 0    | 1     | 0 | 1                            | 0    | 0     | 0 | 0                            | 0    | 0     | 0 | 2     | 56               |
| 2:55 PM                               | 0                                | 0    | 0     | 0 | 0                                | 0    | 1     | 0 | 2                            | 0    | 0     | 0 | 0                            | 0    | 0     | 0 | 3     | 56               |
| 3:00 PM                               | 1                                | 0    | 0     | 0 | 0                                | 0    | 2     | 0 | 4                            | 1    | 1     | 0 | 0                            | 1    | 0     | 0 | 10    | 65               |
| 3:05 PM                               | 0                                | 0    | 0     | 0 | 0                                | 0    | 1     | 0 | 0                            | 3    | 0     | 0 | 0                            | 1    | 0     | 0 | 5     | 68               |
| 3:10 PM                               | 0                                | 0    | 0     | 0 | 0                                | 0    | 1     | 0 | 3                            | 2    | 0     | 0 | 0                            | 0    | 0     | 0 | 6     | 70               |
| 3:15 PM                               | 0                                | 0    | 0     | 0 | 0                                | 0    | 2     | 0 | 0                            | 3    | 0     | 0 | 0                            | 2    | 0     | 0 | 7     | 74               |
| 3:20 PM                               | 1                                | 0    | 0     | 0 | 0                                | 0    | 0     | 0 | 0                            | 0    | 0     | 0 | 0                            | 0    | 0     | 0 | 1     | 71               |
| 3:25 PM                               | 0                                | 0    | 0     | 0 | 0                                | 0    | 2     | 0 | 1                            | 5    | 0     | 0 | 0                            | 0    | 0     | 0 | 8     | 71               |
| 3:30 PM                               | 0                                | 0    | 0     | 0 | 0                                | 0    | 1     | 0 | 1                            | 1    | 1     | 0 | 0                            | 1    | 0     | 0 | 5     | 69               |
| 3:35 PM                               | 0                                | 0    | 0     | 0 | 0                                | 0    | 3     | 0 | 1                            | 1    | 0     | 0 | 0                            | 2    | 1     | 0 | 8     | 70               |
| 3:40 PM                               | 0                                | 0    | 0     | 0 | 0                                | 0    | 1     | 0 | 1                            | 4    | 0     | 0 | 0                            | 3    | 0     | 0 | 9     | 74               |
| 3:45 PM                               | 0                                | 0    | 0     | 0 | 0                                | 0    | 2     | 0 | 2                            | 2    | 0     | 0 | 0                            | 2    | 0     | 0 | 8     | 72               |
| 3:50 PM                               | 0                                | 0    | 0     | 0 | 0                                | 0    | 0     | 0 | 1                            | 0    | 0     | 0 | 0                            | 2    | 0     | 0 | 3     | 73               |
| 3:55 PM                               | 0                                | 0    | 0     | 0 | 0                                | 0    | 1     | 0 | 1                            | 1    | 0     | 0 | 0                            | 3    | 0     | 0 | 6     | 76               |
| 4:00 PM                               | 1                                | 0    | 0     | 0 | 0                                | 0    | 1     | 0 | 0                            | 2    | 0     | 0 | 0                            | 0    | 0     | 0 | 4     | 70               |
| 4:05 PM                               | 0                                | 0    | 0     | 0 | 0                                | 0    | 0     | 0 | 0                            | 1    | 0     | 0 | 0                            | 4    | 0     | 0 | 5     | 70               |
| 4:10 PM                               | 0                                | 0    | 1     | 0 | 1                                | 1    | 1     | 0 | 0                            | 1    | 0     | 0 | 0                            | 2    | 0     | 0 | 7     | 71               |
| 4:15 PM                               | 0                                | 0    | 0     | 0 | 0                                | 0    | 0     | 0 | 1                            | 2    | 0     | 0 | 0                            | 2    | 0     | 0 | 5     | 69               |
| 4:20 PM                               | 0                                | 0    | 0     | 0 | 0                                | 0    | 1     | 0 | 3                            | 2    | 0     | 0 | 0                            | 3    | 0     | 0 | 9     | 77               |
| 4:25 PM                               | 0                                | 0    | 0     | 0 | 0                                | 0    | 1     | 0 | 1                            | 1    | 0     | 0 | 0                            | 1    | 0     | 0 | 4     | 73               |
| 4:30 PM                               | 0                                | 0    | 0     | 0 | 0                                | 0    | 1     | 0 | 2                            | 1    | 0     | 0 | 0                            | 1    | 0     | 0 | 5     | 73               |

## Attachment B

| 5-Min Count Period Beginning At | Scarlet Maple Dr (Northbound) |      |       |   | Scarlet Maple Dr (Southbound) |      |       |   | Smoke Tree Dr (Eastbound) |      |       |   | Smoke Tree Dr (Westbound) |      |       |   | Total | Hourly Totals |    |
|---------------------------------|-------------------------------|------|-------|---|-------------------------------|------|-------|---|---------------------------|------|-------|---|---------------------------|------|-------|---|-------|---------------|----|
|                                 | Left                          | Thru | Right | U | Left                          | Thru | Right | U | Left                      | Thru | Right | U | Left                      | Thru | Right | U |       |               |    |
| 4:35 PM                         | 0                             | 0    | 0     | 0 | 0                             | 0    | 0     | 0 | 0                         | 0    | 0     | 0 | 0                         | 0    | 0     | 0 | 0     | 0             | 65 |
| 4:40 PM                         | 0                             | 0    | 0     | 0 | 0                             | 0    | 1     | 0 | 1                         | 2    | 0     | 0 | 0                         | 0    | 0     | 0 | 0     | 0             | 60 |
| 4:45 PM                         | 0                             | 0    | 0     | 0 | 0                             | 0    | 2     | 0 | 1                         | 1    | 1     | 0 | 0                         | 1    | 0     | 0 | 0     | 0             | 58 |
| 4:50 PM                         | 1                             | 0    | 0     | 0 | 0                             | 0    | 1     | 0 | 0                         | 2    | 0     | 0 | 0                         | 4    | 0     | 0 | 0     | 0             | 63 |
| 4:55 PM                         | 1                             | 0    | 0     | 0 | 0                             | 0    | 0     | 0 | 3                         | 1    | 0     | 0 | 0                         | 0    | 0     | 0 | 0     | 0             | 62 |
| 5:00 PM                         | 1                             | 0    | 0     | 0 | 0                             | 0    | 1     | 0 | 2                         | 2    | 0     | 0 | 0                         | 0    | 0     | 0 | 0     | 0             | 64 |
| 5:05 PM                         | 0                             | 0    | 0     | 0 | 0                             | 0    | 1     | 0 | 1                         | 3    | 1     | 0 | 0                         | 0    | 0     | 0 | 0     | 0             | 65 |
| 5:10 PM                         | 0                             | 0    | 0     | 0 | 0                             | 0    | 1     | 0 | 1                         | 3    | 1     | 0 | 0                         | 1    | 0     | 0 | 0     | 0             | 65 |
| 5:15 PM                         | 0                             | 0    | 0     | 0 | 0                             | 0    | 0     | 0 | 1                         | 3    | 0     | 0 | 0                         | 3    | 0     | 0 | 0     | 0             | 67 |
| 5:20 PM                         | 1                             | 0    | 0     | 0 | 0                             | 0    | 0     | 0 | 0                         | 0    | 1     | 0 | 0                         | 2    | 0     | 0 | 0     | 0             | 62 |
| 5:25 PM                         | 1                             | 0    | 0     | 0 | 0                             | 0    | 1     | 0 | 1                         | 2    | 0     | 0 | 0                         | 1    | 0     | 0 | 0     | 0             | 64 |
| 5:30 PM                         | 0                             | 0    | 0     | 0 | 0                             | 0    | 0     | 0 | 1                         | 4    | 1     | 0 | 0                         | 1    | 0     | 0 | 0     | 0             | 66 |
| 5:35 PM                         | 0                             | 0    | 0     | 0 | 0                             | 0    | 2     | 0 | 0                         | 2    | 1     | 0 | 0                         | 2    | 0     | 0 | 0     | 0             | 73 |
| 5:40 PM                         | 1                             | 0    | 0     | 0 | 0                             | 0    | 1     | 0 | 0                         | 2    | 0     | 0 | 0                         | 0    | 0     | 0 | 0     | 0             | 73 |
| 5:45 PM                         | 1                             | 0    | 0     | 0 | 0                             | 0    | 1     | 0 | 0                         | 1    | 1     | 0 | 0                         | 0    | 0     | 0 | 0     | 0             | 71 |
| 5:50 PM                         | 1                             | 0    | 0     | 0 | 0                             | 0    | 1     | 0 | 1                         | 2    | 0     | 0 | 0                         | 2    | 0     | 0 | 0     | 0             | 70 |
| 5:55 PM                         | 0                             | 0    | 0     | 0 | 0                             | 0    | 2     | 0 | 1                         | 1    | 0     | 0 | 0                         | 0    | 0     | 0 | 0     | 0             | 69 |
| 6:00 PM                         | 0                             | 0    | 0     | 0 | 0                             | 0    | 0     | 0 | 0                         | 2    | 0     | 0 | 0                         | 0    | 0     | 0 | 0     | 0             | 65 |
| 6:05 PM                         | 0                             | 0    | 0     | 0 | 0                             | 0    | 0     | 0 | 0                         | 3    | 0     | 0 | 0                         | 0    | 0     | 0 | 0     | 0             | 62 |
| 6:10 PM                         | 1                             | 0    | 0     | 0 | 0                             | 0    | 1     | 0 | 2                         | 1    | 0     | 0 | 0                         | 2    | 0     | 0 | 0     | 0             | 62 |
| 6:15 PM                         | 0                             | 0    | 0     | 0 | 0                             | 0    | 3     | 0 | 1                         | 4    | 0     | 0 | 0                         | 3    | 0     | 0 | 0     | 0             | 66 |
| 6:20 PM                         | 0                             | 0    | 0     | 0 | 0                             | 0    | 0     | 0 | 0                         | 1    | 0     | 0 | 0                         | 2    | 0     | 0 | 0     | 0             | 65 |
| 6:25 PM                         | 1                             | 0    | 0     | 0 | 0                             | 0    | 0     | 0 | 0                         | 2    | 0     | 0 | 0                         | 2    | 0     | 0 | 0     | 0             | 64 |
| 6:30 PM                         | 0                             | 0    | 0     | 0 | 0                             | 0    | 0     | 0 | 2                         | 3    | 1     | 0 | 0                         | 2    | 0     | 0 | 0     | 0             | 65 |
| 6:35 PM                         | 0                             | 0    | 0     | 0 | 0                             | 0    | 0     | 0 | 1                         | 2    | 1     | 0 | 0                         | 1    | 0     | 0 | 0     | 0             | 63 |
| 6:40 PM                         | 0                             | 0    | 0     | 0 | 0                             | 0    | 1     | 0 | 0                         | 1    | 0     | 0 | 0                         | 5    | 0     | 0 | 0     | 0             | 66 |
| 6:45 PM                         | 0                             | 0    | 0     | 0 | 0                             | 0    | 0     | 0 | 1                         | 2    | 1     | 0 | 0                         | 0    | 0     | 0 | 0     | 0             | 66 |
| 6:50 PM                         | 0                             | 0    | 0     | 0 | 0                             | 0    | 2     | 0 | 1                         | 0    | 0     | 0 | 0                         | 1    | 0     | 0 | 0     | 0             | 63 |
| 6:55 PM                         | 0                             | 0    | 0     | 0 | 0                             | 0    | 1     | 0 | 0                         | 2    | 0     | 0 | 0                         | 2    | 0     | 0 | 0     | 0             | 64 |
| 7:00 PM                         | 0                             | 0    | 0     | 0 | 0                             | 0    | 0     | 0 | 0                         | 1    | 0     | 0 | 0                         | 0    | 0     | 0 | 0     | 0             | 63 |
| 7:05 PM                         | 0                             | 0    | 0     | 0 | 0                             | 0    | 0     | 0 | 2                         | 0    | 0     | 0 | 0                         | 0    | 0     | 0 | 0     | 0             | 62 |
| 7:10 PM                         | 0                             | 0    | 0     | 0 | 0                             | 0    | 0     | 0 | 1                         | 4    | 0     | 0 | 0                         | 0    | 0     | 0 | 0     | 0             | 60 |
| 7:15 PM                         | 0                             | 0    | 0     | 0 | 0                             | 0    | 0     | 0 | 2                         | 0    | 0     | 0 | 0                         | 1    | 0     | 0 | 0     | 0             | 52 |
| 7:20 PM                         | 0                             | 0    | 0     | 0 | 0                             | 0    | 0     | 0 | 0                         | 1    | 0     | 0 | 0                         | 0    | 0     | 0 | 0     | 0             | 50 |
| 7:25 PM                         | 0                             | 0    | 0     | 0 | 0                             | 0    | 1     | 0 | 1                         | 1    | 0     | 0 | 0                         | 0    | 0     | 0 | 0     | 0             | 48 |
| 7:30 PM                         | 0                             | 0    | 0     | 0 | 0                             | 0    | 0     | 0 | 0                         | 0    | 0     | 0 | 0                         | 1    | 0     | 0 | 0     | 0             | 41 |
| 7:35 PM                         | 0                             | 0    | 0     | 0 | 0                             | 0    | 0     | 0 | 1                         | 1    | 0     | 0 | 0                         | 0    | 0     | 0 | 0     | 0             | 38 |
| 7:40 PM                         | 0                             | 0    | 0     | 0 | 0                             | 0    | 0     | 0 | 0                         | 3    | 0     | 0 | 0                         | 1    | 0     | 0 | 0     | 0             | 35 |
| 7:45 PM                         | 0                             | 0    | 0     | 0 | 0                             | 0    | 2     | 0 | 2                         | 1    | 0     | 0 | 0                         | 0    | 0     | 0 | 0     | 0             | 36 |
| 7:50 PM                         | 0                             | 0    | 0     | 0 | 0                             | 0    | 0     | 0 | 1                         | 0    | 0     | 0 | 0                         | 0    | 0     | 0 | 0     | 0             | 33 |
| 7:55 PM                         | 0                             | 0    | 0     | 0 | 0                             | 0    | 0     | 0 | 2                         | 0    | 1     | 0 | 0                         | 0    | 0     | 0 | 0     | 0             | 31 |
| 8:00 PM                         | 0                             | 0    | 0     | 0 | 0                             | 0    | 0     | 0 | 2                         | 1    | 0     | 0 | 0                         | 0    | 0     | 0 | 0     | 0             | 33 |
| 8:05 PM                         | 0                             | 0    | 0     | 0 | 0                             | 0    | 0     | 0 | 2                         | 1    | 0     | 0 | 0                         | 1    | 0     | 0 | 0     | 0             | 35 |
| 8:10 PM                         | 1                             | 0    | 0     | 0 | 0                             | 0    | 1     | 0 | 1                         | 0    | 0     | 0 | 0                         | 0    | 0     | 0 | 0     | 0             | 33 |
| 8:15 PM                         | 0                             | 0    | 0     | 0 | 0                             | 0    | 0     | 0 | 0                         | 1    | 0     | 0 | 0                         | 0    | 0     | 0 | 0     | 0             | 31 |
| 8:20 PM                         | 0                             | 0    | 0     | 0 | 0                             | 0    | 0     | 0 | 0                         | 1    | 1     | 0 | 0                         | 1    | 0     | 0 | 0     | 0             | 33 |
| 8:25 PM                         | 0                             | 0    | 0     | 0 | 0                             | 0    | 1     | 0 | 2                         | 0    | 1     | 0 | 0                         | 0    | 0     | 0 | 0     | 0             | 34 |
| 8:30 PM                         | 0                             | 0    | 0     | 0 | 0                             | 0    | 0     | 0 | 0                         | 1    | 0     | 0 | 0                         | 0    | 0     | 0 | 0     | 0             | 35 |
| 8:35 PM                         | 0                             | 0    | 0     | 0 | 0                             | 0    | 0     | 0 | 0                         | 0    | 0     | 0 | 0                         | 0    | 0     | 0 | 0     | 0             | 33 |
| 8:40 PM                         | 0                             | 0    | 0     | 0 | 0                             | 0    | 0     | 0 | 0                         | 1    | 0     | 0 | 0                         | 1    | 0     | 0 | 0     | 0             | 31 |
| 8:45 PM                         | 0                             | 0    | 0     | 0 | 0                             | 0    | 0     | 0 | 0                         | 1    | 0     | 0 | 0                         | 0    | 0     | 0 | 0     | 0             | 27 |
| 8:50 PM                         | 0                             | 0    | 0     | 0 | 0                             | 0    | 0     | 0 | 0                         | 1    | 0     | 0 | 0                         | 0    | 0     | 0 | 0     | 0             | 27 |
| 8:55 PM                         | 0                             | 0    | 0     | 0 | 0                             | 0    | 0     | 0 | 1                         | 0    | 0     | 0 | 0                         | 0    | 0     | 0 | 0     | 0             | 25 |
| 9:00 PM                         | 0                             | 0    | 0     | 0 | 0                             | 0    | 0     | 0 | 0                         | 0    | 0     | 0 | 0                         | 0    | 0     | 0 | 0     | 0             | 22 |
| 9:05 PM                         | 0                             | 0    | 0     | 0 | 0                             | 0    | 0     | 0 | 0                         | 2    | 0     | 0 | 0                         | 1    | 0     | 0 | 0     | 0             | 21 |
| 9:10 PM                         | 0                             | 0    | 0     | 0 | 0                             | 0    | 0     | 0 | 1                         | 1    | 0     | 0 | 0                         | 0    | 0     | 0 | 0     | 0             | 20 |
| 9:15 PM                         | 0                             | 0    | 0     | 0 | 0                             | 0    | 0     | 0 | 2                         | 1    | 0     | 0 | 0                         | 0    | 0     | 0 | 0     | 0             | 22 |
| 9:20 PM                         | 0                             | 0    | 0     | 0 | 0                             | 0    | 0     | 0 | 0                         | 2    | 0     | 0 | 0                         | 0    | 0     | 0 | 0     | 0             | 21 |
| 9:25 PM                         | 0                             | 0    | 0     | 0 | 0                             | 0    | 0     | 0 | 1                         | 1    | 0     | 0 | 0                         | 0    | 0     | 0 | 0     | 0             | 19 |
| 9:30 PM                         | 0                             | 0    | 0     | 0 | 0                             | 0    | 1     | 0 | 1                         | 0    | 0     | 0 | 0                         | 0    | 0     | 0 | 0     | 0             | 19 |
| 9:35 PM                         | 0                             | 0    | 0     | 0 | 0                             | 0    | 1     | 0 | 1                         | 1    | 0     | 0 | 0                         | 0    | 0     | 0 | 0     | 0             | 22 |
| 9:40 PM                         | 0                             | 0    | 0     | 0 | 0                             | 0    | 0     | 0 | 0                         | 1    | 0     | 0 | 0                         | 0    | 0     | 0 | 0     | 0             | 21 |
| 9:45 PM                         | 0                             | 0    | 0     | 0 | 0                             | 0    | 0     | 0 | 0                         | 2    | 1     | 0 | 0                         | 0    | 0     | 0 | 0     | 0             | 23 |
| 9:50 PM                         | 0                             | 0    | 0     | 0 | 0                             | 0    | 0     | 0 | 0                         | 1    | 0     | 0 | 0                         | 0    | 1     | 0 | 0     | 0             | 24 |
| 9:55 PM                         | 0                             | 0    | 0     | 0 | 0                             | 0    | 0     | 0 | 0                         | 2    | 0     | 0 | 0                         | 0    | 1     | 0 | 0     | 0             | 26 |
| Peak 15-Min Flowrates           | Northbound                    |      |       |   | Southbound                    |      |       |   | Eastbound                 |      |       |   | Westbound                 |      |       |   | Total |               |    |
|                                 | Left                          | Thru | Right | U | Left                          | Thru | Right | U | Left                      | Thru | Right | U | Left                      | Thru | Right | U |       |               |    |
| All Vehicles                    | 0                             | 0    | 0     | 0 | 0                             | 0    | 20    | 0 | 32                        | 24   | 4     | 0 | 0                         | 48   | 0     | 0 | 128   |               |    |
| Heavy Trucks                    | 0                             | 0    | 0     |   | 0                             | 0    | 0     |   | 0                         | 0    | 0     |   | 0                         | 0    | 0     | 0 |       |               |    |
| Buses                           |                               |      |       |   |                               |      |       |   |                           |      |       |   |                           |      |       |   |       |               |    |
| Pedestrians                     |                               | 0    |       |   |                               | 4    |       |   |                           | 0    |       |   |                           | 0    |       | 4 |       |               |    |
| Bicycles                        | 0                             | 0    | 0     |   | 0                             | 0    | 4     |   | 0                         | 0    | 0     |   | 0                         | 0    | 0     | 4 |       |               |    |
| Scoters                         |                               |      |       |   |                               |      |       |   |                           |      |       |   |                           |      |       |   |       |               |    |

Comments:

LOCATION: Celestine Cir -- Merriweather Pl  
 CITY/STATE: Ladera Ranch, CA

QC JOB #: 16966466  
 DATE: Wed, Apr 16 2025

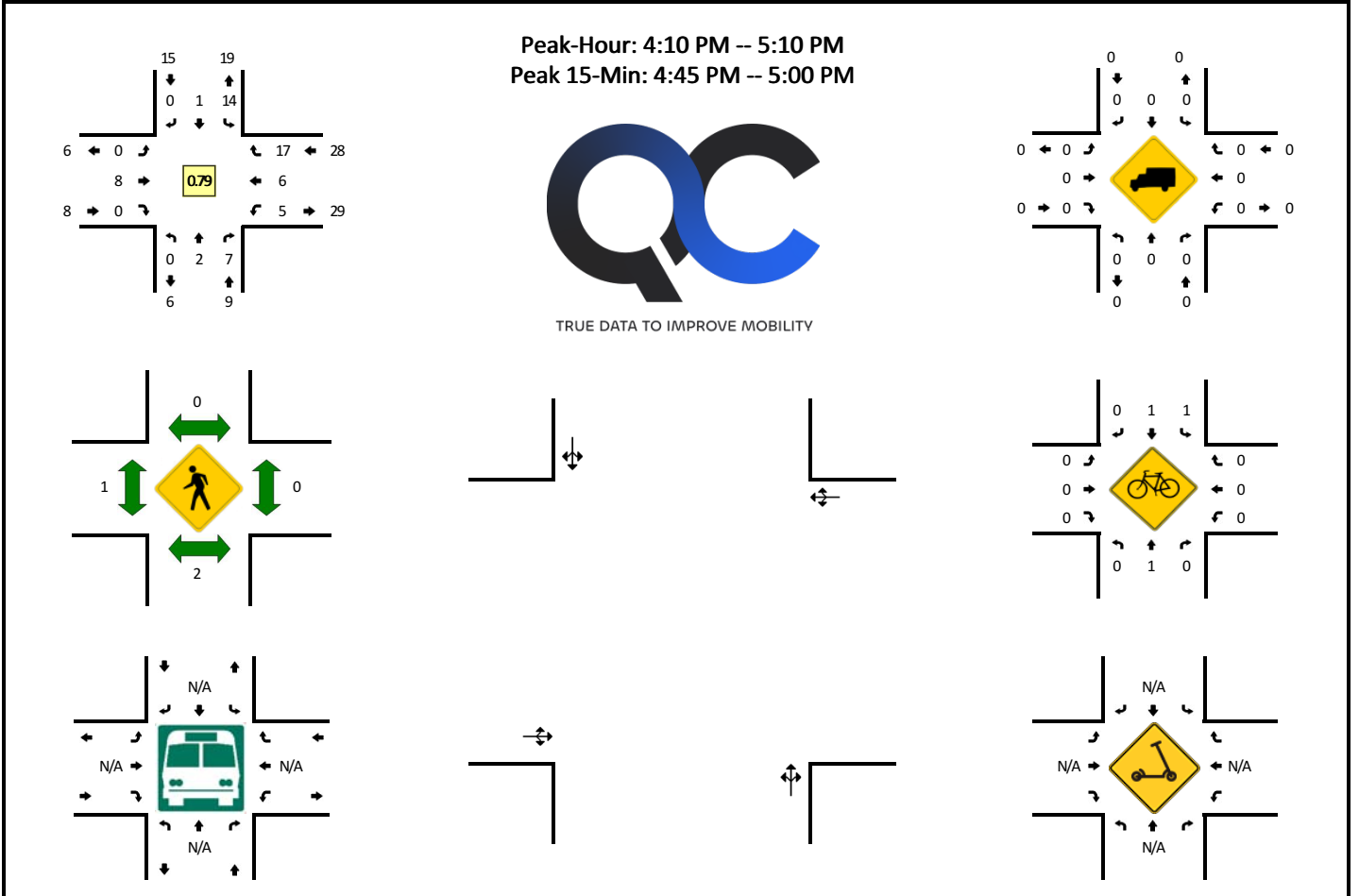

| 5-Min Count Period Beginning At | Celestine Cir (Northbound) |      |       |   | Celestine Cir (Southbound) |      |       |   | Merriweather Pl (Eastbound) |      |       |   | Merriweather Pl (Westbound) |      |       |   | Total | Hourly Totals |
|---------------------------------|----------------------------|------|-------|---|----------------------------|------|-------|---|-----------------------------|------|-------|---|-----------------------------|------|-------|---|-------|---------------|
|                                 | Left                       | Thru | Right | U | Left                       | Thru | Right | U | Left                        | Thru | Right | U | Left                        | Thru | Right | U |       |               |
| 6:00 AM                         | 0                          | 0    | 0     | 0 | 0                          | 0    | 0     | 0 | 0                           | 0    | 0     | 0 | 0                           | 0    | 0     | 0 | 0     | 0             |
| 6:05 AM                         | 0                          | 0    | 0     | 0 | 0                          | 0    | 0     | 0 | 0                           | 0    | 0     | 0 | 0                           | 0    | 0     | 1 | 0     | 1             |
| 6:10 AM                         | 0                          | 0    | 0     | 0 | 1                          | 0    | 0     | 0 | 0                           | 0    | 0     | 0 | 0                           | 0    | 0     | 0 | 0     | 1             |
| 6:15 AM                         | 0                          | 1    | 0     | 0 | 1                          | 0    | 1     | 0 | 0                           | 0    | 0     | 1 | 0                           | 0    | 3     | 0 | 0     | 7             |
| 6:20 AM                         | 0                          | 0    | 0     | 0 | 1                          | 0    | 0     | 0 | 0                           | 0    | 0     | 0 | 0                           | 0    | 0     | 0 | 0     | 1             |
| 6:25 AM                         | 0                          | 0    | 0     | 0 | 1                          | 0    | 0     | 0 | 0                           | 0    | 1     | 0 | 0                           | 0    | 0     | 1 | 0     | 3             |
| 6:30 AM                         | 0                          | 0    | 0     | 0 | 1                          | 0    | 0     | 0 | 0                           | 0    | 0     | 0 | 0                           | 0    | 0     | 0 | 0     | 1             |
| 6:35 AM                         | 0                          | 0    | 0     | 0 | 0                          | 0    | 0     | 0 | 0                           | 0    | 0     | 0 | 0                           | 0    | 0     | 0 | 0     | 0             |
| 6:40 AM                         | 0                          | 0    | 0     | 0 | 0                          | 0    | 0     | 0 | 0                           | 0    | 0     | 0 | 0                           | 0    | 0     | 0 | 0     | 0             |
| 6:45 AM                         | 0                          | 0    | 1     | 0 | 1                          | 1    | 0     | 0 | 0                           | 0    | 0     | 0 | 0                           | 0    | 0     | 0 | 0     | 3             |
| 6:50 AM                         | 0                          | 0    | 0     | 0 | 6                          | 0    | 0     | 0 | 0                           | 0    | 0     | 0 | 0                           | 0    | 1     | 0 | 0     | 7             |
| 6:55 AM                         | 0                          | 0    | 0     | 0 | 3                          | 0    | 0     | 0 | 0                           | 0    | 0     | 0 | 0                           | 0    | 3     | 0 | 0     | 6             |
| 7:00 AM                         | 0                          | 0    | 0     | 0 | 0                          | 0    | 0     | 0 | 0                           | 0    | 3     | 0 | 0                           | 0    | 0     | 0 | 0     | 3             |
| 7:05 AM                         | 0                          | 0    | 0     | 0 | 0                          | 0    | 0     | 0 | 0                           | 0    | 0     | 0 | 0                           | 1    | 2     | 0 | 0     | 3             |
| 7:10 AM                         | 0                          | 0    | 1     | 0 | 1                          | 0    | 0     | 0 | 0                           | 0    | 0     | 0 | 0                           | 0    | 0     | 0 | 0     | 2             |
| 7:15 AM                         | 0                          | 0    | 1     | 0 | 4                          | 0    | 0     | 0 | 0                           | 0    | 0     | 0 | 0                           | 0    | 1     | 0 | 0     | 6             |
| 7:20 AM                         | 0                          | 0    | 0     | 0 | 2                          | 0    | 0     | 0 | 0                           | 0    | 1     | 0 | 0                           | 0    | 0     | 4 | 0     | 7             |
| 7:25 AM                         | 0                          | 0    | 1     | 0 | 0                          | 0    | 0     | 0 | 0                           | 0    | 2     | 0 | 0                           | 0    | 0     | 0 | 0     | 3             |
| 7:30 AM                         | 0                          | 0    | 0     | 0 | 2                          | 0    | 0     | 0 | 0                           | 0    | 2     | 0 | 0                           | 0    | 0     | 0 | 0     | 4             |
| 7:35 AM                         | 0                          | 0    | 1     | 0 | 0                          | 0    | 0     | 0 | 0                           | 0    | 1     | 0 | 0                           | 0    | 1     | 0 | 0     | 3             |
| 7:40 AM                         | 0                          | 0    | 0     | 0 | 0                          | 0    | 0     | 0 | 0                           | 0    | 0     | 0 | 0                           | 0    | 0     | 0 | 0     | 0             |
| 7:45 AM                         | 0                          | 0    | 1     | 0 | 3                          | 0    | 0     | 0 | 0                           | 0    | 0     | 0 | 0                           | 0    | 1     | 0 | 0     | 5             |
| 7:50 AM                         | 0                          | 0    | 2     | 0 | 2                          | 0    | 0     | 0 | 0                           | 0    | 0     | 0 | 0                           | 1    | 0     | 0 | 0     | 5             |
| 7:55 AM                         | 0                          | 0    | 1     | 0 | 0                          | 0    | 0     | 0 | 0                           | 0    | 0     | 0 | 0                           | 1    | 2     | 0 | 0     | 4             |
| 8:00 AM                         | 0                          | 0    | 0     | 0 | 2                          | 0    | 0     | 0 | 0                           | 0    | 1     | 0 | 0                           | 0    | 1     | 0 | 0     | 4             |
| 8:05 AM                         | 0                          | 0    | 1     | 0 | 1                          | 0    | 0     | 0 | 0                           | 0    | 1     | 0 | 0                           | 0    | 1     | 0 | 0     | 4             |
| 8:10 AM                         | 0                          | 0    | 0     | 0 | 1                          | 0    | 0     | 0 | 0                           | 0    | 0     | 0 | 0                           | 0    | 1     | 3 | 0     | 5             |
| 8:15 AM                         | 0                          | 0    | 0     | 0 | 0                          | 0    | 0     | 0 | 0                           | 0    | 0     | 0 | 0                           | 0    | 0     | 0 | 0     | 0             |
| 8:20 AM                         | 0                          | 0    | 2     | 0 | 0                          | 0    | 0     | 0 | 0                           | 0    | 0     | 0 | 0                           | 0    | 1     | 0 | 0     | 3             |
| 8:25 AM                         | 0                          | 0    | 1     | 0 | 0                          | 0    | 0     | 0 | 0                           | 0    | 0     | 0 | 0                           | 1    | 1     | 0 | 0     | 3             |
| 8:30 AM                         | 0                          | 0    | 1     | 0 | 0                          | 0    | 0     | 0 | 0                           | 0    | 0     | 0 | 0                           | 0    | 1     | 0 | 0     | 2             |
| 8:35 AM                         | 0                          | 0    | 0     | 0 | 1                          | 0    | 0     | 0 | 0                           | 0    | 0     | 0 | 0                           | 1    | 0     | 1 | 0     | 3             |
| 8:40 AM                         | 0                          | 0    | 0     | 0 | 0                          | 0    | 0     | 0 | 0                           | 0    | 3     | 0 | 0                           | 0    | 1     | 1 | 0     | 5             |
| 8:45 AM                         | 0                          | 0    | 1     | 0 | 0                          | 0    | 0     | 0 | 0                           | 0    | 1     | 0 | 0                           | 0    | 0     | 0 | 0     | 2             |
| 8:50 AM                         | 0                          | 0    | 0     | 0 | 1                          | 0    | 0     | 0 | 0                           | 0    | 0     | 0 | 0                           | 0    | 0     | 0 | 0     | 1             |
| 8:55 AM                         | 0                          | 0    | 0     | 0 | 1                          | 0    | 0     | 0 | 0                           | 0    | 0     | 0 | 0                           | 0    | 0     | 0 | 0     | 1             |
| 9:00 AM                         | 0                          | 0    | 0     | 0 | 0                          | 0    | 0     | 0 | 0                           | 0    | 0     | 0 | 0                           | 0    | 1     | 0 | 0     | 1             |
| 9:05 AM                         | 0                          | 0    | 0     | 0 | 0                          | 0    | 0     | 0 | 0                           | 0    | 1     | 0 | 0                           | 0    | 0     | 0 | 0     | 1             |

Attachment B

| 5-Min Count Period Beginning At | Celestine Cir (Northbound) |      |       |   | Celestine Cir (Southbound) |      |       |   | Merriweather Pl (Eastbound) |      |       |   | Merriweather Pl (Westbound) |      |       |   | Total | Hourly Totals |
|---------------------------------|----------------------------|------|-------|---|----------------------------|------|-------|---|-----------------------------|------|-------|---|-----------------------------|------|-------|---|-------|---------------|
|                                 | Left                       | Thru | Right | U | Left                       | Thru | Right | U | Left                        | Thru | Right | U | Left                        | Thru | Right | U |       |               |
| 9:10 AM                         | 0                          | 0    | 0     | 0 | 1                          | 0    | 0     | 0 | 0                           | 1    | 0     | 0 | 0                           | 0    | 1     | 0 | 3     | 25            |
| 9:15 AM                         | 0                          | 0    | 0     | 0 | 3                          | 0    | 0     | 0 | 0                           | 0    | 1     | 0 | 0                           | 1    | 0     | 0 | 5     | 30            |
| 9:20 AM                         | 0                          | 0    | 1     | 0 | 1                          | 0    | 0     | 0 | 0                           | 0    | 0     | 0 | 0                           | 0    | 0     | 0 | 2     | 29            |
| 9:25 AM                         | 0                          | 0    | 0     | 0 | 0                          | 0    | 0     | 0 | 0                           | 0    | 0     | 0 | 0                           | 0    | 2     | 0 | 2     | 28            |
| 9:30 AM                         | 0                          | 0    | 0     | 0 | 0                          | 0    | 0     | 0 | 0                           | 0    | 1     | 0 | 0                           | 0    | 0     | 1 | 2     | 28            |
| 9:35 AM                         | 0                          | 0    | 0     | 0 | 0                          | 0    | 0     | 0 | 0                           | 0    | 0     | 0 | 1                           | 0    | 0     | 0 | 1     | 26            |
| 9:40 AM                         | 0                          | 0    | 1     | 0 | 1                          | 0    | 0     | 0 | 0                           | 0    | 0     | 0 | 0                           | 0    | 0     | 0 | 2     | 23            |
| 9:45 AM                         | 0                          | 0    | 0     | 0 | 0                          | 0    | 0     | 0 | 0                           | 0    | 0     | 0 | 0                           | 0    | 0     | 0 | 0     | 21            |
| 9:50 AM                         | 0                          | 0    | 0     | 0 | 0                          | 0    | 0     | 0 | 0                           | 0    | 0     | 0 | 0                           | 0    | 0     | 0 | 0     | 20            |
| 9:55 AM                         | 0                          | 0    | 0     | 0 | 0                          | 0    | 0     | 0 | 0                           | 0    | 0     | 0 | 0                           | 2    | 0     | 0 | 2     | 21            |
| 10:00 AM                        | 0                          | 1    | 1     | 0 | 3                          | 0    | 0     | 0 | 0                           | 0    | 0     | 0 | 0                           | 0    | 0     | 0 | 5     | 25            |
| 10:05 AM                        | 0                          | 0    | 1     | 0 | 1                          | 0    | 0     | 0 | 0                           | 0    | 1     | 0 | 0                           | 0    | 0     | 0 | 3     | 27            |
| 10:10 AM                        | 0                          | 0    | 1     | 0 | 0                          | 0    | 0     | 0 | 0                           | 0    | 1     | 0 | 0                           | 0    | 0     | 1 | 3     | 27            |
| 10:15 AM                        | 0                          | 0    | 1     | 0 | 1                          | 0    | 0     | 0 | 0                           | 0    | 0     | 0 | 1                           | 0    | 1     | 0 | 4     | 26            |
| 10:20 AM                        | 0                          | 0    | 1     | 0 | 0                          | 0    | 0     | 0 | 0                           | 0    | 0     | 0 | 0                           | 0    | 0     | 0 | 1     | 25            |
| 10:25 AM                        | 0                          | 0    | 1     | 0 | 1                          | 1    | 0     | 0 | 0                           | 0    | 0     | 0 | 0                           | 0    | 0     | 0 | 3     | 26            |
| 10:30 AM                        | 0                          | 0    | 0     | 0 | 0                          | 0    | 0     | 0 | 0                           | 0    | 0     | 0 | 0                           | 1    | 2     | 0 | 3     | 27            |
| 10:35 AM                        | 0                          | 0    | 0     | 0 | 1                          | 0    | 0     | 0 | 0                           | 0    | 0     | 0 | 0                           | 0    | 1     | 0 | 2     | 28            |
| 10:40 AM                        | 0                          | 0    | 0     | 0 | 0                          | 0    | 1     | 0 | 0                           | 0    | 0     | 0 | 0                           | 1    | 1     | 0 | 3     | 29            |
| 10:45 AM                        | 0                          | 0    | 1     | 0 | 0                          | 0    | 0     | 0 | 0                           | 0    | 1     | 1 | 0                           | 0    | 0     | 0 | 3     | 32            |
| 10:50 AM                        | 0                          | 0    | 1     | 0 | 0                          | 0    | 0     | 0 | 0                           | 0    | 0     | 0 | 0                           | 0    | 0     | 0 | 1     | 33            |
| 10:55 AM                        | 0                          | 0    | 0     | 0 | 0                          | 0    | 0     | 0 | 0                           | 0    | 0     | 0 | 1                           | 0    | 0     | 0 | 1     | 32            |
| 11:00 AM                        | 0                          | 0    | 0     | 0 | 0                          | 0    | 0     | 0 | 0                           | 0    | 0     | 0 | 0                           | 0    | 0     | 0 | 0     | 27            |
| 11:05 AM                        | 0                          | 0    | 0     | 0 | 0                          | 0    | 0     | 0 | 0                           | 0    | 0     | 0 | 0                           | 0    | 0     | 0 | 0     | 24            |
| 11:10 AM                        | 0                          | 0    | 0     | 0 | 0                          | 0    | 0     | 0 | 0                           | 0    | 0     | 0 | 0                           | 0    | 0     | 0 | 0     | 21            |
| 11:15 AM                        | 0                          | 0    | 0     | 0 | 2                          | 0    | 0     | 0 | 0                           | 0    | 0     | 0 | 0                           | 0    | 0     | 0 | 2     | 19            |
| 11:20 AM                        | 0                          | 0    | 1     | 0 | 1                          | 0    | 0     | 0 | 0                           | 0    | 0     | 0 | 1                           | 0    | 0     | 0 | 3     | 21            |
| 11:25 AM                        | 0                          | 0    | 0     | 0 | 0                          | 0    | 0     | 0 | 0                           | 0    | 0     | 0 | 0                           | 0    | 0     | 0 | 0     | 18            |
| 11:30 AM                        | 0                          | 0    | 0     | 0 | 0                          | 0    | 0     | 0 | 0                           | 0    | 0     | 0 | 0                           | 0    | 1     | 0 | 1     | 16            |
| 11:35 AM                        | 0                          | 0    | 0     | 0 | 0                          | 0    | 0     | 0 | 0                           | 0    | 1     | 0 | 0                           | 0    | 0     | 0 | 1     | 15            |
| 11:40 AM                        | 1                          | 0    | 0     | 0 | 0                          | 0    | 0     | 0 | 0                           | 0    | 0     | 0 | 0                           | 0    | 0     | 0 | 1     | 13            |
| 11:45 AM                        | 0                          | 0    | 0     | 0 | 0                          | 0    | 0     | 0 | 0                           | 0    | 1     | 0 | 0                           | 0    | 0     | 0 | 1     | 11            |
| 11:50 AM                        | 0                          | 0    | 0     | 0 | 0                          | 0    | 0     | 0 | 0                           | 0    | 0     | 0 | 0                           | 0    | 0     | 0 | 0     | 10            |
| 11:55 AM                        | 0                          | 0    | 1     | 0 | 1                          | 0    | 0     | 0 | 0                           | 0    | 0     | 0 | 0                           | 0    | 1     | 0 | 3     | 12            |
| 12:00 PM                        | 0                          | 0    | 0     | 0 | 0                          | 0    | 0     | 0 | 0                           | 0    | 0     | 0 | 0                           | 1    | 2     | 0 | 3     | 15            |
| 12:05 PM                        | 0                          | 0    | 1     | 0 | 1                          | 0    | 0     | 0 | 0                           | 0    | 1     | 0 | 0                           | 0    | 0     | 0 | 3     | 18            |
| 12:10 PM                        | 0                          | 0    | 1     | 0 | 0                          | 0    | 0     | 0 | 0                           | 0    | 0     | 0 | 1                           | 0    | 0     | 0 | 2     | 20            |
| 12:15 PM                        | 0                          | 0    | 1     | 0 | 1                          | 0    | 0     | 0 | 0                           | 0    | 0     | 0 | 1                           | 0    | 0     | 0 | 3     | 21            |
| 12:20 PM                        | 0                          | 0    | 0     | 0 | 0                          | 1    | 0     | 0 | 0                           | 0    | 0     | 0 | 1                           | 0    | 2     | 0 | 4     | 22            |
| 12:25 PM                        | 0                          | 0    | 0     | 0 | 0                          | 0    | 0     | 0 | 0                           | 0    | 0     | 0 | 1                           | 0    | 1     | 0 | 2     | 24            |
| 12:30 PM                        | 0                          | 0    | 0     | 0 | 1                          | 0    | 1     | 0 | 0                           | 0    | 0     | 0 | 0                           | 0    | 0     | 0 | 2     | 25            |
| 12:35 PM                        | 0                          | 0    | 0     | 0 | 0                          | 0    | 0     | 0 | 0                           | 0    | 0     | 1 | 0                           | 0    | 0     | 0 | 1     | 25            |
| 12:40 PM                        | 0                          | 0    | 0     | 0 | 0                          | 0    | 0     | 0 | 0                           | 0    | 0     | 0 | 0                           | 0    | 1     | 0 | 1     | 25            |
| 12:45 PM                        | 0                          | 0    | 0     | 0 | 0                          | 0    | 0     | 0 | 0                           | 0    | 0     | 0 | 1                           | 0    | 1     | 0 | 2     | 26            |
| 12:50 PM                        | 0                          | 0    | 2     | 0 | 2                          | 0    | 0     | 0 | 0                           | 0    | 0     | 0 | 0                           | 0    | 1     | 0 | 5     | 31            |
| 12:55 PM                        | 0                          | 0    | 0     | 0 | 0                          | 0    | 0     | 0 | 0                           | 0    | 0     | 0 | 0                           | 1    | 1     | 0 | 2     | 30            |
| 1:00 PM                         | 0                          | 0    | 0     | 0 | 1                          | 0    | 0     | 0 | 0                           | 0    | 0     | 0 | 1                           | 2    | 0     | 0 | 4     | 31            |
| 1:05 PM                         | 0                          | 0    | 0     | 0 | 2                          | 0    | 0     | 0 | 1                           | 1    | 0     | 0 | 0                           | 0    | 0     | 0 | 4     | 32            |
| 1:10 PM                         | 0                          | 0    | 2     | 0 | 0                          | 0    | 0     | 0 | 0                           | 1    | 0     | 0 | 0                           | 0    | 2     | 0 | 5     | 35            |
| 1:15 PM                         | 0                          | 1    | 1     | 0 | 0                          | 0    | 0     | 0 | 0                           | 0    | 0     | 0 | 0                           | 2    | 1     | 0 | 5     | 37            |
| 1:20 PM                         | 1                          | 0    | 0     | 0 | 0                          | 1    | 1     | 0 | 0                           | 3    | 1     | 0 | 1                           | 0    | 0     | 0 | 8     | 41            |
| 1:25 PM                         | 0                          | 0    | 0     | 0 | 3                          | 0    | 0     | 0 | 0                           | 0    | 0     | 0 | 1                           | 0    | 2     | 0 | 6     | 45            |
| 1:30 PM                         | 0                          | 0    | 0     | 0 | 0                          | 0    | 0     | 0 | 0                           | 0    | 0     | 0 | 0                           | 0    | 0     | 0 | 0     | 43            |
| 1:35 PM                         | 0                          | 0    | 0     | 0 | 0                          | 0    | 0     | 0 | 0                           | 0    | 0     | 0 | 1                           | 0    | 0     | 0 | 1     | 43            |
| 1:40 PM                         | 0                          | 0    | 1     | 0 | 0                          | 0    | 0     | 0 | 0                           | 2    | 0     | 0 | 1                           | 0    | 1     | 0 | 5     | 47            |
| 1:45 PM                         | 0                          | 0    | 1     | 0 | 1                          | 0    | 0     | 0 | 0                           | 0    | 0     | 0 | 0                           | 0    | 0     | 0 | 2     | 47            |
| 1:50 PM                         | 0                          | 2    | 0     | 0 | 2                          | 0    | 0     | 0 | 0                           | 0    | 0     | 0 | 0                           | 0    | 1     | 0 | 5     | 47            |
| 1:55 PM                         | 0                          | 0    | 0     | 0 | 0                          | 1    | 0     | 0 | 0                           | 0    | 1     | 0 | 0                           | 2    | 0     | 0 | 4     | 49            |
| 2:00 PM                         | 0                          | 0    | 1     | 0 | 1                          | 0    | 0     | 0 | 0                           | 0    | 0     | 0 | 0                           | 2    | 0     | 0 | 4     | 49            |
| 2:05 PM                         | 0                          | 0    | 1     | 0 | 0                          | 1    | 0     | 0 | 0                           | 0    | 1     | 0 | 0                           | 0    | 1     | 0 | 4     | 49            |
| 2:10 PM                         | 0                          | 1    | 0     | 0 | 1                          | 0    | 0     | 0 | 0                           | 1    | 0     | 0 | 0                           | 0    | 0     | 0 | 3     | 47            |
| 2:15 PM                         | 0                          | 0    | 0     | 0 | 0                          | 0    | 0     | 0 | 0                           | 0    | 0     | 0 | 0                           | 1    | 0     | 0 | 1     | 43            |
| 2:20 PM                         | 0                          | 0    | 1     | 0 | 0                          | 0    | 0     | 0 | 0                           | 0    | 0     | 0 | 1                           | 0    | 0     | 0 | 2     | 37            |
| 2:25 PM                         | 0                          | 0    | 1     | 0 | 0                          | 0    | 0     | 0 | 0                           | 0    | 0     | 0 | 0                           | 0    | 3     | 0 | 4     | 35            |
| 2:30 PM                         | 0                          | 0    | 0     | 0 | 1                          | 0    | 0     | 0 | 0                           | 0    | 0     | 0 | 1                           | 0    | 0     | 0 | 2     | 37            |
| 2:35 PM                         | 0                          | 0    | 0     | 0 | 2                          | 0    | 0     | 0 | 0                           | 0    | 1     | 0 | 0                           | 0    | 1     | 0 | 4     | 40            |
| 2:40 PM                         | 0                          | 0    | 0     | 0 | 0                          | 0    | 0     | 0 | 0                           | 0    | 0     | 0 | 0                           | 0    | 0     | 0 | 0     | 35            |
| 2:45 PM                         | 0                          | 0    | 0     | 0 | 0                          | 0    | 0     | 0 | 0                           | 2    | 0     | 0 | 0                           | 0    | 1     | 0 | 3     | 36            |
| 2:50 PM                         | 0                          | 0    | 0     | 0 | 0                          | 1    | 0     | 0 | 0                           | 0    | 0     | 0 | 0                           | 1    | 0     | 0 | 2     | 33            |
| 2:55 PM                         | 0                          | 0    | 2     | 0 | 3                          | 0    | 0     | 0 | 0                           | 0    | 0     | 0 | 0                           | 1    | 2     | 0 | 8     | 37            |
| 3:00 PM                         | 0                          | 0    | 0     | 0 | 2                          | 0    | 0     | 0 | 0                           | 0    | 1     | 0 | 0                           | 3    | 1     | 0 | 7     | 40            |
| 3:05 PM                         | 0                          | 0    | 0     | 0 | 0                          | 0    | 0     | 0 | 0                           | 0    | 0     | 0 | 2                           | 1    | 1     | 0 | 4     | 40            |
| 3:10 PM                         | 0                          | 0    | 1     | 0 | 3                          | 0    | 0     | 0 | 0                           | 0    | 0     | 0 | 0                           | 1    | 1     | 0 | 6     | 43            |
| 3:15 PM                         | 0                          | 0    | 0     | 0 | 0                          | 0    | 0     | 0 | 0                           | 0    | 0     | 0 | 1                           | 1    | 0     | 0 | 2     | 44            |
| 3:20 PM                         | 0                          | 1    | 0     | 0 | 0                          | 1    | 0     | 0 | 0                           | 0    | 0     | 0 | 0                           | 1    | 0     | 0 | 3     | 45            |
| 3:25 PM                         | 0                          | 0    | 0     | 0 | 1                          | 0    | 0     | 0 | 0                           | 0    | 0     | 0 | 0                           | 1    | 2     | 0 | 4     | 45            |
| 3:30 PM                         | 0                          | 0    | 0     | 0 | 1                          | 0    | 0     | 0 | 0                           | 0    | 1     | 0 | 0                           | 2    | 1     | 0 | 5     | 48            |
| 3:35 PM                         | 0                          | 0    | 0     | 0 | 0                          | 0    | 0     | 0 | 0                           | 0    | 1     | 0 | 0                           | 0    | 2     | 0 | 3     | 47            |
| 3:40 PM                         | 0                          | 0    | 0     | 0 | 0                          | 0    | 0     | 0 | 0                           | 0    | 0     | 0 | 2                           | 1    | 2     | 0 | 5     | 52            |
| 3:45 PM                         | 0                          | 0    | 1     | 0 | 1                          | 0    | 0     | 0 | 0                           | 0    | 0     | 0 | 0                           | 1    | 0     | 0 | 3     | 52            |
| 3:50 PM                         | 0                          | 0    | 0     | 0 | 1                          | 0    | 0     | 0 | 0                           | 0    | 0     | 0 | 0                           | 1    | 0     | 0 | 2     | 52            |
| 3:55 PM                         | 0                          | 0    | 1     | 0 | 1                          | 0    | 0     | 0 | 0                           | 2    | 0     | 0 | 0                           | 1    | 1     | 0 | 6     | 50            |
| 4:00 PM                         | 0                          | 0    | 0     | 0 | 1                          | 0    | 0     | 0 | 0                           | 0    | 1     | 0 | 0                           | 1    | 0     | 0 | 4     | 47            |
| 4:05 PM                         | 0                          | 0    | 1     | 0 | 0                          | 0    | 0     | 0 | 0                           | 0    | 1     | 0 | 0                           | 1    | 0     | 0 | 3     | 46            |
| 4:10 PM                         | 0                          | 0    | 1     | 0 | 1                          | 0    | 0     | 0 | 0                           | 0    | 0     | 0 | 1                           | 1    | 1     | 0 | 5     | 45            |
| 4:15 PM                         | 0                          | 0    | 0     | 0 | 2                          | 0    | 0     | 0 | 0                           | 0    | 1     | 0 | 0                           | 0    | 0     | 0 | 3     | 46            |
| 4:20 PM                         | 0                          | 0    | 0     | 0 | 0                          | 0    | 0     | 0 | 0                           | 0    | 1     | 0 | 0                           | 0    | 1     | 1 | 3     | 46            |
| 4:25 PM                         | 0                          | 0    | 2     | 0 | 1                          | 0    | 0     | 0 | 0                           | 0    | 1     | 0 | 0                           | 0    | 2     | 0 | 6     | 48            |

### Attachment B

| 5-Min Count Period Beginning At | Celestine Cir (Northbound) |      |       |   | Celestine Cir (Southbound) |      |       |   | Merriweather Pl (Eastbound) |      |       |   | Merriweather Pl (Westbound) |      |       |   | Total | Hourly Totals |
|---------------------------------|----------------------------|------|-------|---|----------------------------|------|-------|---|-----------------------------|------|-------|---|-----------------------------|------|-------|---|-------|---------------|
|                                 | Left                       | Thru | Right | U | Left                       | Thru | Right | U | Left                        | Thru | Right | U | Left                        | Thru | Right | U |       |               |
| 4:30 PM                         | 0                          | 2    | 0     | 0 | 1                          | 0    | 0     | 0 | 0                           | 1    | 0     | 0 | 3                           | 0    | 0     | 0 | 7     | 50            |
| 4:35 PM                         | 0                          | 0    | 0     | 0 | 0                          | 0    | 0     | 0 | 0                           | 0    | 0     | 0 | 0                           | 0    | 4     | 0 | 4     | 51            |
| 4:40 PM                         | 0                          | 0    | 1     | 0 | 1                          | 0    | 0     | 0 | 0                           | 1    | 0     | 0 | 0                           | 0    | 0     | 0 | 3     | 49            |
| 4:45 PM                         | 0                          | 0    | 2     | 0 | 0                          | 0    | 0     | 0 | 0                           | 0    | 0     | 0 | 0                           | 1    | 1     | 0 | 4     | 50            |
| 4:50 PM                         | 0                          | 0    | 0     | 0 | 3                          | 1    | 0     | 0 | 0                           | 1    | 0     | 0 | 0                           | 0    | 3     | 0 | 8     | 56            |
| 4:55 PM                         | 0                          | 0    | 0     | 0 | 4                          | 0    | 0     | 0 | 0                           | 0    | 0     | 0 | 0                           | 1    | 2     | 0 | 7     | 57            |
| 5:00 PM                         | 0                          | 0    | 0     | 0 | 0                          | 0    | 0     | 0 | 0                           | 1    | 0     | 0 | 0                           | 1    | 1     | 0 | 3     | 56            |
| 5:05 PM                         | 0                          | 0    | 1     | 0 | 1                          | 0    | 0     | 0 | 0                           | 1    | 0     | 0 | 1                           | 1    | 2     | 0 | 7     | 60            |
| 5:10 PM                         | 0                          | 0    | 0     | 0 | 0                          | 0    | 0     | 0 | 0                           | 0    | 0     | 0 | 0                           | 0    | 1     | 0 | 1     | 56            |
| 5:15 PM                         | 0                          | 0    | 1     | 0 | 1                          | 0    | 0     | 0 | 0                           | 0    | 0     | 0 | 1                           | 0    | 0     | 0 | 3     | 56            |
| 5:20 PM                         | 0                          | 0    | 1     | 0 | 0                          | 0    | 0     | 0 | 0                           | 0    | 0     | 0 | 0                           | 0    | 0     | 0 | 1     | 54            |
| 5:25 PM                         | 0                          | 0    | 0     | 0 | 2                          | 0    | 0     | 0 | 0                           | 0    | 0     | 0 | 1                           | 1    | 2     | 0 | 6     | 54            |
| 5:30 PM                         | 0                          | 0    | 0     | 0 | 1                          | 0    | 0     | 0 | 0                           | 0    | 0     | 0 | 0                           | 0    | 0     | 0 | 1     | 48            |
| 5:35 PM                         | 0                          | 0    | 0     | 0 | 1                          | 0    | 0     | 0 | 0                           | 1    | 0     | 0 | 1                           | 0    | 0     | 0 | 3     | 47            |
| 5:40 PM                         | 0                          | 0    | 1     | 0 | 1                          | 0    | 0     | 0 | 0                           | 0    | 0     | 0 | 0                           | 1    | 2     | 0 | 5     | 49            |
| 5:45 PM                         | 0                          | 0    | 0     | 0 | 2                          | 0    | 0     | 0 | 0                           | 2    | 0     | 0 | 1                           | 2    | 1     | 0 | 8     | 53            |
| 5:50 PM                         | 0                          | 0    | 0     | 0 | 1                          | 0    | 0     | 0 | 0                           | 0    | 0     | 0 | 2                           | 1    | 2     | 0 | 6     | 51            |
| 5:55 PM                         | 0                          | 1    | 2     | 0 | 1                          | 1    | 0     | 0 | 0                           | 0    | 0     | 0 | 0                           | 0    | 2     | 0 | 7     | 51            |
| 6:00 PM                         | 0                          | 0    | 1     | 0 | 2                          | 0    | 0     | 0 | 0                           | 0    | 0     | 0 | 0                           | 0    | 0     | 0 | 3     | 51            |
| 6:05 PM                         | 0                          | 0    | 1     | 0 | 0                          | 0    | 0     | 0 | 0                           | 0    | 0     | 0 | 0                           | 1    | 0     | 0 | 2     | 46            |
| 6:10 PM                         | 0                          | 0    | 0     | 0 | 2                          | 0    | 0     | 0 | 0                           | 0    | 0     | 0 | 1                           | 0    | 2     | 0 | 5     | 50            |
| 6:15 PM                         | 0                          | 0    | 1     | 0 | 2                          | 0    | 0     | 0 | 0                           | 0    | 0     | 0 | 1                           | 2    | 2     | 0 | 8     | 55            |
| 6:20 PM                         | 0                          | 0    | 0     | 0 | 2                          | 0    | 0     | 0 | 0                           | 0    | 1     | 0 | 0                           | 0    | 1     | 0 | 4     | 58            |
| 6:25 PM                         | 0                          | 0    | 0     | 0 | 0                          | 0    | 0     | 0 | 0                           | 1    | 0     | 0 | 0                           | 0    | 1     | 0 | 2     | 54            |
| 6:30 PM                         | 0                          | 0    | 0     | 0 | 4                          | 0    | 0     | 0 | 0                           | 0    | 0     | 0 | 0                           | 0    | 1     | 0 | 5     | 58            |
| 6:35 PM                         | 0                          | 1    | 0     | 0 | 1                          | 0    | 0     | 0 | 0                           | 0    | 1     | 0 | 1                           | 1    | 0     | 0 | 5     | 60            |
| 6:40 PM                         | 0                          | 0    | 0     | 0 | 1                          | 0    | 0     | 0 | 0                           | 0    | 0     | 0 | 1                           | 0    | 1     | 0 | 3     | 58            |
| 6:45 PM                         | 0                          | 1    | 1     | 0 | 0                          | 0    | 0     | 0 | 0                           | 1    | 0     | 0 | 0                           | 0    | 0     | 0 | 3     | 53            |
| 6:50 PM                         | 0                          | 0    | 1     | 0 | 1                          | 0    | 0     | 0 | 0                           | 0    | 0     | 0 | 0                           | 1    | 1     | 0 | 4     | 51            |
| 6:55 PM                         | 0                          | 0    | 0     | 0 | 0                          | 0    | 0     | 0 | 0                           | 0    | 0     | 0 | 0                           | 0    | 1     | 0 | 1     | 45            |
| 7:00 PM                         | 0                          | 0    | 0     | 0 | 1                          | 0    | 0     | 0 | 0                           | 0    | 0     | 0 | 0                           | 0    | 3     | 0 | 4     | 46            |
| 7:05 PM                         | 0                          | 0    | 0     | 0 | 0                          | 0    | 0     | 0 | 0                           | 0    | 0     | 0 | 0                           | 0    | 2     | 0 | 2     | 46            |
| 7:10 PM                         | 0                          | 0    | 0     | 0 | 0                          | 1    | 0     | 0 | 0                           | 0    | 0     | 0 | 0                           | 0    | 0     | 0 | 1     | 42            |
| 7:15 PM                         | 0                          | 0    | 0     | 0 | 0                          | 0    | 0     | 0 | 0                           | 2    | 0     | 0 | 0                           | 1    | 0     | 0 | 3     | 37            |
| 7:20 PM                         | 0                          | 1    | 0     | 0 | 0                          | 0    | 0     | 0 | 0                           | 0    | 0     | 0 | 1                           | 0    | 1     | 0 | 3     | 36            |
| 7:25 PM                         | 0                          | 0    | 0     | 0 | 0                          | 1    | 0     | 0 | 0                           | 0    | 0     | 0 | 1                           | 0    | 0     | 0 | 2     | 36            |
| 7:30 PM                         | 0                          | 0    | 0     | 0 | 0                          | 0    | 0     | 0 | 0                           | 0    | 0     | 0 | 0                           | 1    | 0     | 0 | 1     | 32            |
| 7:35 PM                         | 0                          | 0    | 1     | 0 | 1                          | 0    | 0     | 0 | 0                           | 2    | 0     | 0 | 0                           | 0    | 0     | 0 | 4     | 31            |
| 7:40 PM                         | 0                          | 0    | 0     | 0 | 0                          | 0    | 0     | 0 | 0                           | 0    | 0     | 0 | 1                           | 0    | 0     | 0 | 1     | 29            |
| 7:45 PM                         | 0                          | 0    | 1     | 0 | 1                          | 0    | 0     | 0 | 0                           | 0    | 0     | 0 | 1                           | 0    | 0     | 0 | 3     | 29            |
| 7:50 PM                         | 0                          | 1    | 0     | 0 | 1                          | 0    | 0     | 0 | 0                           | 0    | 0     | 0 | 0                           | 0    | 1     | 0 | 3     | 28            |
| 7:55 PM                         | 0                          | 0    | 0     | 0 | 1                          | 0    | 0     | 0 | 0                           | 0    | 0     | 0 | 0                           | 0    | 0     | 0 | 1     | 28            |
| 8:00 PM                         | 0                          | 0    | 0     | 0 | 1                          | 0    | 0     | 0 | 0                           | 0    | 0     | 0 | 1                           | 0    | 2     | 0 | 4     | 28            |
| 8:05 PM                         | 0                          | 0    | 1     | 0 | 0                          | 0    | 0     | 0 | 0                           | 0    | 0     | 0 | 0                           | 0    | 0     | 0 | 1     | 27            |
| 8:10 PM                         | 0                          | 0    | 1     | 0 | 0                          | 0    | 0     | 0 | 0                           | 0    | 0     | 0 | 0                           | 0    | 2     | 0 | 3     | 29            |
| 8:15 PM                         | 0                          | 0    | 0     | 0 | 0                          | 0    | 0     | 0 | 0                           | 0    | 0     | 0 | 0                           | 0    | 0     | 0 | 0     | 26            |
| 8:20 PM                         | 0                          | 0    | 0     | 0 | 0                          | 0    | 0     | 0 | 0                           | 0    | 0     | 0 | 0                           | 1    | 2     | 0 | 3     | 26            |
| 8:25 PM                         | 0                          | 0    | 0     | 0 | 1                          | 0    | 0     | 0 | 0                           | 0    | 0     | 0 | 1                           | 0    | 0     | 0 | 2     | 26            |
| 8:30 PM                         | 0                          | 0    | 0     | 0 | 0                          | 0    | 0     | 0 | 0                           | 0    | 0     | 0 | 1                           | 0    | 0     | 0 | 1     | 26            |
| 8:35 PM                         | 0                          | 0    | 1     | 0 | 0                          | 0    | 0     | 0 | 0                           | 0    | 0     | 0 | 0                           | 0    | 0     | 0 | 1     | 23            |
| 8:40 PM                         | 0                          | 0    | 1     | 0 | 0                          | 0    | 0     | 0 | 0                           | 1    | 0     | 0 | 0                           | 1    | 0     | 0 | 3     | 25            |
| 8:45 PM                         | 0                          | 0    | 0     | 0 | 0                          | 0    | 0     | 0 | 0                           | 0    | 0     | 0 | 0                           | 1    | 0     | 0 | 1     | 23            |
| 8:50 PM                         | 0                          | 0    | 0     | 0 | 0                          | 0    | 0     | 0 | 0                           | 0    | 0     | 0 | 0                           | 1    | 0     | 0 | 1     | 21            |
| 8:55 PM                         | 0                          | 0    | 0     | 0 | 2                          | 0    | 0     | 0 | 0                           | 0    | 0     | 0 | 0                           | 1    | 4     | 0 | 7     | 27            |
| 9:00 PM                         | 0                          | 0    | 0     | 0 | 0                          | 0    | 0     | 0 | 0                           | 0    | 0     | 0 | 0                           | 0    | 0     | 0 | 0     | 23            |
| 9:05 PM                         | 0                          | 0    | 1     | 0 | 0                          | 0    | 0     | 0 | 0                           | 0    | 0     | 0 | 0                           | 0    | 1     | 0 | 2     | 24            |
| 9:10 PM                         | 0                          | 0    | 0     | 0 | 1                          | 0    | 0     | 0 | 0                           | 0    | 0     | 0 | 0                           | 0    | 0     | 0 | 1     | 22            |
| 9:15 PM                         | 0                          | 0    | 0     | 0 | 0                          | 1    | 0     | 0 | 0                           | 1    | 0     | 0 | 0                           | 0    | 2     | 0 | 4     | 26            |
| 9:20 PM                         | 0                          | 0    | 0     | 0 | 1                          | 0    | 0     | 0 | 0                           | 0    | 0     | 0 | 1                           | 1    | 1     | 0 | 4     | 27            |
| 9:25 PM                         | 0                          | 0    | 0     | 0 | 0                          | 0    | 0     | 0 | 0                           | 0    | 0     | 0 | 1                           | 0    | 0     | 0 | 1     | 26            |
| 9:30 PM                         | 0                          | 0    | 0     | 0 | 0                          | 0    | 0     | 0 | 0                           | 0    | 0     | 0 | 0                           | 0    | 0     | 0 | 0     | 25            |
| 9:35 PM                         | 0                          | 0    | 0     | 0 | 1                          | 0    | 0     | 0 | 0                           | 0    | 0     | 0 | 0                           | 3    | 0     | 0 | 4     | 28            |
| 9:40 PM                         | 0                          | 0    | 0     | 0 | 0                          | 0    | 0     | 0 | 0                           | 0    | 0     | 0 | 0                           | 1    | 1     | 0 | 2     | 27            |
| 9:45 PM                         | 0                          | 0    | 0     | 0 | 0                          | 0    | 0     | 0 | 0                           | 0    | 0     | 0 | 0                           | 0    | 1     | 0 | 1     | 27            |
| 9:50 PM                         | 0                          | 0    | 0     | 0 | 0                          | 0    | 0     | 0 | 0                           | 0    | 0     | 0 | 1                           | 1    | 0     | 0 | 2     | 28            |
| 9:55 PM                         | 0                          | 0    | 0     | 0 | 0                          | 0    | 0     | 0 | 0                           | 0    | 0     | 0 | 1                           | 0    | 0     | 0 | 1     | 22            |
| Peak 15-Min Flowrates           | Northbound                 |      |       |   | Southbound                 |      |       |   | Eastbound                   |      |       |   | Westbound                   |      |       |   | Total |               |
|                                 | Left                       | Thru | Right | U | Left                       | Thru | Right | U | Left                        | Thru | Right | U | Left                        | Thru | Right | U |       |               |
| All Vehicles                    | 0                          | 0    | 8     | 0 | 28                         | 4    | 0     | 0 | 0                           | 4    | 0     | 0 | 0                           | 8    | 24    | 0 | 76    |               |
| Heavy Trucks                    | 0                          | 0    | 0     | 0 | 0                          | 0    | 0     | 0 | 0                           | 0    | 0     | 0 | 0                           | 0    | 0     | 0 | 0     |               |
| Buses                           |                            |      |       |   |                            |      |       |   |                             |      |       |   |                             |      |       |   |       |               |
| Pedestrians                     |                            | 8    |       |   |                            | 0    |       |   |                             | 0    |       |   |                             | 0    |       |   | 8     |               |
| Bicycles                        | 0                          | 0    | 0     |   | 0                          | 0    | 0     |   | 0                           | 0    | 0     |   | 0                           | 0    | 0     |   | 0     |               |
| Scoters                         |                            |      |       |   |                            |      |       |   |                             |      |       |   |                             |      |       |   |       |               |

Comments:

LOCATION: Vivido St -- Futuro St  
 CITY/STATE: Rancho Mission Viejo, CA

QC JOB #: 16966467  
 DATE: Wed, Apr 16 2025

Peak-Hour: 7:10 AM -- 8:10 AM  
 Peak 15-Min: 7:30 AM -- 7:45 AM

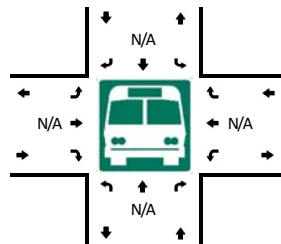
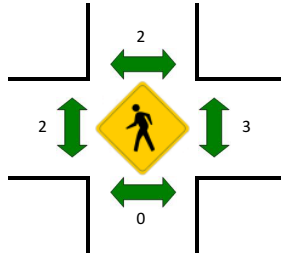
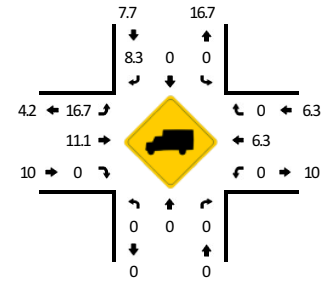
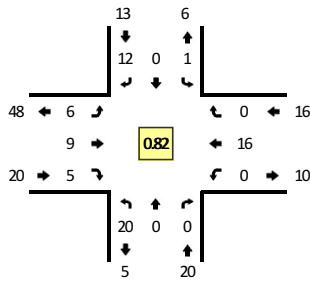

| 5-Min Count Period Beginning At | Vivido St (Northbound) |      |       |   | Vivido St (Southbound) |      |       |   | Futuro St (Eastbound) |      |       |   | Futuro St (Westbound) |      |       |   | Total | Hourly Totals |
|---------------------------------|------------------------|------|-------|---|------------------------|------|-------|---|-----------------------|------|-------|---|-----------------------|------|-------|---|-------|---------------|
|                                 | Left                   | Thru | Right | U | Left                   | Thru | Right | U | Left                  | Thru | Right | U | Left                  | Thru | Right | U |       |               |
| 6:00 AM                         | 0                      | 0    | 0     | 0 | 0                      | 0    | 0     | 0 | 0                     | 0    | 0     | 0 | 0                     | 0    | 0     | 0 | 0     | 0             |
| 6:05 AM                         | 0                      | 0    | 0     | 0 | 0                      | 0    | 0     | 0 | 0                     | 0    | 0     | 0 | 0                     | 0    | 0     | 0 | 0     | 0             |
| 6:10 AM                         | 0                      | 0    | 0     | 0 | 0                      | 0    | 1     | 0 | 0                     | 0    | 0     | 0 | 0                     | 0    | 0     | 0 | 0     | 1             |
| 6:15 AM                         | 0                      | 0    | 0     | 0 | 0                      | 0    | 0     | 0 | 1                     | 0    | 0     | 0 | 0                     | 0    | 0     | 0 | 0     | 1             |
| 6:20 AM                         | 0                      | 0    | 0     | 0 | 0                      | 0    | 0     | 0 | 0                     | 0    | 0     | 0 | 0                     | 0    | 0     | 0 | 0     | 0             |
| 6:25 AM                         | 1                      | 0    | 0     | 0 | 0                      | 0    | 0     | 0 | 0                     | 1    | 0     | 0 | 0                     | 0    | 0     | 0 | 0     | 2             |
| 6:30 AM                         | 0                      | 0    | 0     | 0 | 0                      | 0    | 0     | 0 | 0                     | 0    | 0     | 0 | 0                     | 1    | 0     | 0 | 0     | 1             |
| 6:35 AM                         | 0                      | 0    | 0     | 0 | 0                      | 0    | 0     | 0 | 0                     | 0    | 0     | 0 | 0                     | 1    | 0     | 0 | 0     | 1             |
| 6:40 AM                         | 1                      | 0    | 0     | 0 | 0                      | 0    | 1     | 0 | 0                     | 0    | 0     | 0 | 0                     | 0    | 0     | 0 | 0     | 2             |
| 6:45 AM                         | 1                      | 0    | 0     | 0 | 0                      | 0    | 0     | 0 | 0                     | 0    | 0     | 0 | 0                     | 1    | 0     | 0 | 0     | 2             |
| 6:50 AM                         | 0                      | 0    | 0     | 0 | 0                      | 0    | 2     | 0 | 1                     | 0    | 0     | 0 | 0                     | 0    | 0     | 0 | 0     | 3             |
| 6:55 AM                         | 0                      | 0    | 0     | 0 | 0                      | 0    | 0     | 0 | 0                     | 0    | 1     | 0 | 0                     | 1    | 0     | 0 | 0     | 2             |
| 7:00 AM                         | 0                      | 0    | 0     | 0 | 0                      | 0    | 0     | 0 | 0                     | 0    | 1     | 0 | 0                     | 0    | 0     | 0 | 0     | 1             |
| 7:05 AM                         | 0                      | 0    | 0     | 0 | 0                      | 0    | 0     | 0 | 0                     | 0    | 0     | 0 | 0                     | 1    | 0     | 0 | 0     | 1             |
| 7:10 AM                         | 0                      | 0    | 0     | 0 | 0                      | 0    | 3     | 0 | 1                     | 1    | 0     | 0 | 0                     | 1    | 0     | 0 | 0     | 6             |
| 7:15 AM                         | 3                      | 0    | 0     | 0 | 0                      | 0    | 1     | 0 | 0                     | 0    | 1     | 0 | 0                     | 1    | 0     | 0 | 0     | 6             |
| 7:20 AM                         | 2                      | 0    | 0     | 0 | 0                      | 0    | 1     | 0 | 0                     | 0    | 0     | 0 | 0                     | 0    | 0     | 0 | 0     | 3             |
| 7:25 AM                         | 2                      | 0    | 0     | 0 | 0                      | 0    | 1     | 0 | 0                     | 0    | 1     | 0 | 0                     | 4    | 0     | 0 | 0     | 8             |
| 7:30 AM                         | 2                      | 0    | 0     | 0 | 0                      | 0    | 1     | 0 | 0                     | 0    | 0     | 0 | 0                     | 0    | 0     | 0 | 0     | 3             |
| 7:35 AM                         | 2                      | 0    | 0     | 0 | 0                      | 0    | 3     | 0 | 0                     | 2    | 0     | 0 | 0                     | 2    | 0     | 0 | 0     | 9             |
| 7:40 AM                         | 3                      | 0    | 0     | 0 | 0                      | 0    | 1     | 0 | 1                     | 0    | 0     | 0 | 0                     | 4    | 0     | 0 | 0     | 9             |
| 7:45 AM                         | 2                      | 0    | 0     | 0 | 0                      | 0    | 0     | 0 | 0                     | 0    | 0     | 0 | 0                     | 1    | 0     | 0 | 0     | 3             |
| 7:50 AM                         | 0                      | 0    | 0     | 0 | 0                      | 0    | 0     | 0 | 1                     | 2    | 2     | 0 | 0                     | 0    | 0     | 0 | 0     | 5             |
| 7:55 AM                         | 2                      | 0    | 0     | 0 | 1                      | 0    | 0     | 0 | 2                     | 1    | 0     | 0 | 0                     | 2    | 0     | 0 | 0     | 8             |
| 8:00 AM                         | 0                      | 0    | 0     | 0 | 0                      | 0    | 0     | 0 | 1                     | 1    | 1     | 0 | 0                     | 0    | 0     | 0 | 0     | 3             |
| 8:05 AM                         | 2                      | 0    | 0     | 0 | 0                      | 0    | 1     | 0 | 0                     | 2    | 0     | 0 | 0                     | 1    | 0     | 0 | 0     | 6             |
| 8:10 AM                         | 0                      | 0    | 0     | 0 | 0                      | 0    | 2     | 0 | 0                     | 1    | 1     | 0 | 0                     | 1    | 0     | 0 | 0     | 5             |
| 8:15 AM                         | 0                      | 0    | 0     | 0 | 0                      | 0    | 0     | 0 | 1                     | 1    | 1     | 0 | 0                     | 0    | 0     | 0 | 0     | 3             |
| 8:20 AM                         | 0                      | 0    | 0     | 0 | 0                      | 0    | 1     | 0 | 0                     | 0    | 0     | 0 | 0                     | 1    | 0     | 0 | 0     | 2             |
| 8:25 AM                         | 0                      | 0    | 0     | 0 | 0                      | 0    | 0     | 0 | 0                     | 2    | 0     | 0 | 0                     | 0    | 0     | 0 | 0     | 2             |
| 8:30 AM                         | 0                      | 0    | 0     | 0 | 0                      | 0    | 1     | 0 | 3                     | 1    | 1     | 0 | 0                     | 0    | 0     | 0 | 0     | 6             |
| 8:35 AM                         | 0                      | 0    | 0     | 0 | 0                      | 1    | 2     | 0 | 1                     | 0    | 0     | 0 | 0                     | 3    | 0     | 0 | 0     | 7             |
| 8:40 AM                         | 2                      | 0    | 0     | 0 | 0                      | 0    | 0     | 0 | 1                     | 0    | 1     | 0 | 0                     | 2    | 0     | 0 | 0     | 6             |
| 8:45 AM                         | 0                      | 0    | 0     | 0 | 0                      | 0    | 1     | 0 | 2                     | 0    | 1     | 0 | 0                     | 0    | 0     | 0 | 0     | 4             |
| 8:50 AM                         | 1                      | 0    | 0     | 0 | 0                      | 0    | 0     | 0 | 0                     | 0    | 1     | 0 | 0                     | 2    | 0     | 0 | 0     | 4             |
| 8:55 AM                         | 1                      | 0    | 0     | 0 | 0                      | 0    | 1     | 0 | 2                     | 0    | 0     | 0 | 0                     | 0    | 0     | 0 | 0     | 4             |
| 9:00 AM                         | 0                      | 0    | 0     | 0 | 0                      | 0    | 1     | 0 | 1                     | 0    | 0     | 0 | 0                     | 0    | 0     | 0 | 0     | 2             |
| 9:05 AM                         | 1                      | 0    | 0     | 0 | 0                      | 0    | 0     | 0 | 0                     | 0    | 0     | 0 | 0                     | 0    | 0     | 0 | 0     | 1             |

Attachment B

| 5-Min Count<br>Period<br>Beginning At | Vivido St<br>(Northbound) |      |       |   | Vivido St<br>(Southbound) |      |       |   | Futuro St<br>(Eastbound) |      |       |   | Futuro St<br>(Westbound) |      |       |   | Total | Hourly<br>Totals |
|---------------------------------------|---------------------------|------|-------|---|---------------------------|------|-------|---|--------------------------|------|-------|---|--------------------------|------|-------|---|-------|------------------|
|                                       | Left                      | Thru | Right | U | Left                      | Thru | Right | U | Left                     | Thru | Right | U | Left                     | Thru | Right | U |       |                  |
| 9:10 AM                               | 1                         | 0    | 0     | 0 | 0                         | 0    | 1     | 0 | 0                        | 0    | 1     | 0 | 0                        | 0    | 0     | 0 | 3     | 44               |
| 9:15 AM                               | 1                         | 0    | 0     | 0 | 0                         | 0    | 1     | 0 | 1                        | 0    | 0     | 0 | 0                        | 0    | 0     | 0 | 3     | 44               |
| 9:20 AM                               | 1                         | 0    | 0     | 0 | 0                         | 0    | 0     | 0 | 2                        | 0    | 0     | 0 | 0                        | 0    | 0     | 0 | 3     | 45               |
| 9:25 AM                               | 0                         | 0    | 0     | 0 | 0                         | 0    | 0     | 0 | 0                        | 1    | 1     | 0 | 0                        | 1    | 0     | 0 | 3     | 46               |
| 9:30 AM                               | 0                         | 0    | 0     | 0 | 0                         | 0    | 3     | 0 | 2                        | 0    | 0     | 0 | 0                        | 3    | 0     | 0 | 8     | 48               |
| 9:35 AM                               | 1                         | 0    | 0     | 0 | 0                         | 0    | 0     | 0 | 0                        | 0    | 3     | 0 | 0                        | 0    | 0     | 0 | 4     | 45               |
| 9:40 AM                               | 1                         | 0    | 0     | 0 | 0                         | 0    | 0     | 0 | 1                        | 0    | 0     | 0 | 0                        | 0    | 0     | 0 | 2     | 41               |
| 9:45 AM                               | 1                         | 0    | 0     | 0 | 0                         | 0    | 1     | 0 | 0                        | 0    | 0     | 0 | 0                        | 0    | 0     | 0 | 2     | 39               |
| 9:50 AM                               | 0                         | 0    | 0     | 0 | 0                         | 0    | 0     | 0 | 0                        | 0    | 0     | 0 | 0                        | 0    | 0     | 0 | 0     | 35               |
| 9:55 AM                               | 1                         | 0    | 0     | 0 | 0                         | 0    | 0     | 0 | 0                        | 0    | 0     | 0 | 0                        | 0    | 0     | 0 | 1     | 32               |
| 10:00 AM                              | 0                         | 0    | 0     | 0 | 0                         | 0    | 1     | 0 | 0                        | 0    | 0     | 0 | 0                        | 0    | 0     | 0 | 1     | 31               |
| 10:05 AM                              | 0                         | 0    | 0     | 0 | 0                         | 0    | 0     | 0 | 0                        | 0    | 0     | 0 | 0                        | 1    | 0     | 0 | 2     | 32               |
| 10:10 AM                              | 0                         | 0    | 0     | 0 | 0                         | 0    | 1     | 0 | 1                        | 0    | 0     | 0 | 0                        | 0    | 0     | 0 | 2     | 31               |
| 10:15 AM                              | 0                         | 0    | 0     | 0 | 0                         | 0    | 0     | 0 | 0                        | 0    | 3     | 0 | 0                        | 0    | 0     | 0 | 3     | 31               |
| 10:20 AM                              | 0                         | 0    | 0     | 0 | 0                         | 0    | 2     | 0 | 1                        | 0    | 0     | 0 | 0                        | 0    | 0     | 0 | 3     | 31               |
| 10:25 AM                              | 1                         | 0    | 0     | 0 | 0                         | 0    | 1     | 0 | 0                        | 2    | 2     | 0 | 0                        | 0    | 0     | 0 | 6     | 34               |
| 10:30 AM                              | 2                         | 0    | 0     | 0 | 0                         | 0    | 0     | 0 | 1                        | 0    | 0     | 0 | 0                        | 1    | 0     | 0 | 4     | 30               |
| 10:35 AM                              | 0                         | 0    | 0     | 0 | 0                         | 0    | 0     | 0 | 0                        | 0    | 0     | 0 | 0                        | 0    | 0     | 0 | 0     | 26               |
| 10:40 AM                              | 0                         | 0    | 0     | 0 | 0                         | 0    | 1     | 0 | 1                        | 0    | 1     | 0 | 0                        | 0    | 0     | 0 | 3     | 27               |
| 10:45 AM                              | 0                         | 0    | 0     | 0 | 0                         | 0    | 2     | 0 | 1                        | 1    | 1     | 0 | 0                        | 0    | 0     | 0 | 5     | 30               |
| 10:50 AM                              | 1                         | 0    | 0     | 0 | 0                         | 0    | 0     | 0 | 0                        | 0    | 1     | 0 | 0                        | 1    | 0     | 0 | 3     | 33               |
| 10:55 AM                              | 0                         | 0    | 0     | 0 | 0                         | 0    | 0     | 0 | 0                        | 0    | 0     | 0 | 0                        | 2    | 0     | 0 | 2     | 34               |
| 11:00 AM                              | 0                         | 0    | 0     | 0 | 0                         | 0    | 3     | 0 | 0                        | 0    | 0     | 0 | 0                        | 0    | 0     | 0 | 3     | 36               |
| 11:05 AM                              | 0                         | 0    | 0     | 0 | 0                         | 0    | 1     | 0 | 2                        | 0    | 0     | 0 | 0                        | 0    | 0     | 0 | 3     | 37               |
| 11:10 AM                              | 1                         | 0    | 0     | 0 | 0                         | 0    | 0     | 0 | 1                        | 0    | 0     | 0 | 0                        | 0    | 0     | 0 | 2     | 37               |
| 11:15 AM                              | 2                         | 0    | 0     | 0 | 0                         | 0    | 0     | 0 | 0                        | 0    | 0     | 0 | 0                        | 0    | 0     | 0 | 2     | 36               |
| 11:20 AM                              | 0                         | 0    | 0     | 0 | 0                         | 0    | 0     | 0 | 0                        | 0    | 0     | 0 | 0                        | 0    | 0     | 0 | 0     | 33               |
| 11:25 AM                              | 0                         | 0    | 0     | 0 | 0                         | 0    | 1     | 0 | 1                        | 0    | 0     | 0 | 0                        | 0    | 0     | 0 | 2     | 29               |
| 11:30 AM                              | 0                         | 0    | 0     | 0 | 0                         | 0    | 1     | 0 | 2                        | 0    | 1     | 0 | 0                        | 1    | 0     | 0 | 5     | 30               |
| 11:35 AM                              | 1                         | 0    | 0     | 0 | 0                         | 0    | 0     | 0 | 2                        | 0    | 0     | 0 | 0                        | 0    | 0     | 0 | 3     | 33               |
| 11:40 AM                              | 0                         | 0    | 0     | 0 | 0                         | 0    | 1     | 0 | 1                        | 0    | 1     | 0 | 0                        | 0    | 0     | 0 | 3     | 33               |
| 11:45 AM                              | 1                         | 0    | 0     | 0 | 0                         | 0    | 0     | 0 | 0                        | 0    | 0     | 0 | 0                        | 0    | 0     | 0 | 1     | 29               |
| 11:50 AM                              | 1                         | 0    | 0     | 0 | 0                         | 0    | 0     | 0 | 0                        | 0    | 0     | 0 | 0                        | 1    | 0     | 0 | 2     | 28               |
| 11:55 AM                              | 0                         | 0    | 0     | 0 | 0                         | 0    | 1     | 0 | 0                        | 0    | 1     | 0 | 0                        | 0    | 0     | 0 | 2     | 28               |
| 12:00 PM                              | 0                         | 0    | 0     | 0 | 0                         | 0    | 0     | 0 | 0                        | 0    | 0     | 0 | 0                        | 1    | 0     | 0 | 1     | 26               |
| 12:05 PM                              | 0                         | 0    | 0     | 0 | 0                         | 0    | 3     | 0 | 0                        | 0    | 0     | 0 | 0                        | 0    | 0     | 0 | 3     | 26               |
| 12:10 PM                              | 0                         | 0    | 0     | 0 | 0                         | 0    | 0     | 0 | 1                        | 0    | 4     | 0 | 0                        | 0    | 0     | 0 | 5     | 29               |
| 12:15 PM                              | 0                         | 0    | 0     | 0 | 0                         | 0    | 0     | 0 | 3                        | 0    | 0     | 0 | 0                        | 0    | 0     | 0 | 3     | 30               |
| 12:20 PM                              | 0                         | 0    | 0     | 0 | 0                         | 0    | 1     | 0 | 0                        | 0    | 0     | 0 | 0                        | 1    | 0     | 0 | 2     | 32               |
| 12:25 PM                              | 0                         | 0    | 0     | 0 | 0                         | 0    | 0     | 0 | 0                        | 0    | 1     | 0 | 0                        | 1    | 0     | 0 | 2     | 32               |
| 12:30 PM                              | 1                         | 0    | 0     | 0 | 1                         | 0    | 0     | 0 | 0                        | 1    | 1     | 0 | 0                        | 0    | 0     | 0 | 4     | 31               |
| 12:35 PM                              | 1                         | 0    | 0     | 0 | 0                         | 0    | 2     | 0 | 0                        | 1    | 0     | 0 | 0                        | 1    | 0     | 0 | 5     | 33               |
| 12:40 PM                              | 1                         | 0    | 0     | 0 | 0                         | 0    | 1     | 0 | 1                        | 0    | 0     | 0 | 0                        | 0    | 1     | 0 | 4     | 34               |
| 12:45 PM                              | 1                         | 0    | 0     | 0 | 0                         | 0    | 0     | 0 | 0                        | 1    | 0     | 0 | 0                        | 0    | 0     | 0 | 2     | 35               |
| 12:50 PM                              | 0                         | 0    | 0     | 0 | 0                         | 0    | 2     | 0 | 0                        | 2    | 0     | 0 | 0                        | 1    | 0     | 0 | 5     | 38               |
| 12:55 PM                              | 4                         | 0    | 0     | 0 | 0                         | 0    | 1     | 0 | 1                        | 1    | 3     | 0 | 0                        | 2    | 0     | 0 | 12    | 48               |
| 1:00 PM                               | 1                         | 0    | 0     | 0 | 0                         | 0    | 0     | 0 | 1                        | 1    | 1     | 0 | 0                        | 0    | 0     | 0 | 4     | 51               |
| 1:05 PM                               | 1                         | 0    | 1     | 0 | 0                         | 0    | 0     | 0 | 1                        | 1    | 1     | 0 | 0                        | 0    | 0     | 0 | 5     | 53               |
| 1:10 PM                               | 1                         | 0    | 0     | 0 | 0                         | 0    | 1     | 0 | 0                        | 0    | 0     | 0 | 0                        | 0    | 0     | 0 | 2     | 50               |
| 1:15 PM                               | 1                         | 0    | 0     | 0 | 0                         | 0    | 0     | 0 | 0                        | 1    | 1     | 0 | 0                        | 0    | 1     | 0 | 4     | 51               |
| 1:20 PM                               | 0                         | 0    | 0     | 0 | 0                         | 0    | 2     | 0 | 1                        | 0    | 1     | 0 | 0                        | 1    | 0     | 0 | 5     | 54               |
| 1:25 PM                               | 1                         | 0    | 0     | 0 | 0                         | 0    | 0     | 0 | 0                        | 0    | 1     | 0 | 0                        | 0    | 0     | 0 | 2     | 54               |
| 1:30 PM                               | 1                         | 0    | 0     | 0 | 0                         | 0    | 0     | 0 | 0                        | 1    | 1     | 0 | 0                        | 0    | 0     | 0 | 3     | 53               |
| 1:35 PM                               | 0                         | 0    | 0     | 0 | 0                         | 0    | 0     | 0 | 0                        | 4    | 1     | 0 | 0                        | 0    | 0     | 0 | 5     | 53               |
| 1:40 PM                               | 1                         | 0    | 0     | 0 | 0                         | 0    | 0     | 0 | 2                        | 0    | 0     | 0 | 0                        | 0    | 0     | 0 | 3     | 52               |
| 1:45 PM                               | 1                         | 0    | 0     | 0 | 0                         | 0    | 0     | 0 | 1                        | 2    | 0     | 0 | 0                        | 2    | 0     | 0 | 6     | 56               |
| 1:50 PM                               | 0                         | 0    | 0     | 0 | 0                         | 0    | 3     | 0 | 0                        | 0    | 1     | 0 | 0                        | 0    | 0     | 0 | 4     | 55               |
| 1:55 PM                               | 0                         | 0    | 0     | 0 | 0                         | 0    | 1     | 0 | 0                        | 0    | 0     | 0 | 0                        | 0    | 0     | 0 | 1     | 44               |
| 2:00 PM                               | 0                         | 0    | 0     | 0 | 0                         | 0    | 0     | 0 | 1                        | 0    | 1     | 0 | 0                        | 1    | 0     | 0 | 3     | 43               |
| 2:05 PM                               | 0                         | 0    | 0     | 0 | 0                         | 0    | 0     | 0 | 0                        | 1    | 0     | 0 | 0                        | 0    | 0     | 0 | 1     | 39               |
| 2:10 PM                               | 1                         | 0    | 0     | 0 | 0                         | 0    | 1     | 0 | 2                        | 2    | 1     | 0 | 0                        | 0    | 0     | 0 | 7     | 44               |
| 2:15 PM                               | 1                         | 0    | 0     | 0 | 0                         | 0    | 1     | 0 | 1                        | 0    | 0     | 0 | 0                        | 0    | 0     | 0 | 3     | 43               |
| 2:20 PM                               | 1                         | 0    | 0     | 0 | 0                         | 0    | 0     | 0 | 0                        | 1    | 1     | 0 | 0                        | 0    | 0     | 0 | 3     | 41               |
| 2:25 PM                               | 1                         | 0    | 0     | 0 | 0                         | 0    | 1     | 0 | 0                        | 0    | 0     | 0 | 0                        | 2    | 0     | 0 | 4     | 43               |
| 2:30 PM                               | 0                         | 0    | 0     | 0 | 0                         | 0    | 0     | 0 | 1                        | 0    | 1     | 0 | 0                        | 0    | 0     | 0 | 2     | 42               |
| 2:35 PM                               | 0                         | 0    | 0     | 0 | 0                         | 0    | 0     | 0 | 0                        | 0    | 0     | 0 | 0                        | 0    | 0     | 0 | 0     | 37               |
| 2:40 PM                               | 2                         | 0    | 0     | 0 | 0                         | 0    | 0     | 0 | 3                        | 2    | 2     | 0 | 0                        | 1    | 0     | 0 | 10    | 44               |
| 2:45 PM                               | 0                         | 0    | 0     | 0 | 0                         | 0    | 2     | 0 | 0                        | 1    | 0     | 0 | 0                        | 0    | 0     | 0 | 3     | 41               |
| 2:50 PM                               | 1                         | 0    | 0     | 0 | 0                         | 0    | 1     | 0 | 0                        | 0    | 0     | 0 | 0                        | 2    | 0     | 0 | 4     | 41               |
| 2:55 PM                               | 0                         | 0    | 0     | 0 | 0                         | 0    | 0     | 0 | 1                        | 1    | 1     | 0 | 0                        | 0    | 0     | 0 | 3     | 43               |
| 3:00 PM                               | 1                         | 0    | 0     | 0 | 0                         | 0    | 1     | 0 | 0                        | 1    | 0     | 0 | 0                        | 1    | 0     | 0 | 4     | 44               |
| 3:05 PM                               | 1                         | 0    | 0     | 0 | 0                         | 0    | 1     | 0 | 0                        | 0    | 2     | 0 | 0                        | 1    | 0     | 0 | 5     | 48               |
| 3:10 PM                               | 0                         | 0    | 0     | 0 | 0                         | 0    | 0     | 0 | 0                        | 0    | 0     | 0 | 0                        | 1    | 0     | 0 | 1     | 42               |
| 3:15 PM                               | 0                         | 0    | 0     | 0 | 0                         | 0    | 0     | 0 | 0                        | 1    | 1     | 0 | 0                        | 0    | 0     | 0 | 2     | 41               |
| 3:20 PM                               | 0                         | 0    | 0     | 0 | 0                         | 0    | 1     | 0 | 2                        | 2    | 1     | 0 | 0                        | 3    | 0     | 0 | 9     | 47               |
| 3:25 PM                               | 0                         | 0    | 0     | 0 | 0                         | 0    | 0     | 0 | 1                        | 1    | 2     | 0 | 0                        | 0    | 0     | 0 | 4     | 47               |
| 3:30 PM                               | 1                         | 0    | 1     | 0 | 0                         | 0    | 2     | 0 | 1                        | 3    | 1     | 0 | 0                        | 0    | 0     | 0 | 9     | 54               |
| 3:35 PM                               | 1                         | 0    | 0     | 0 | 0                         | 0    | 1     | 0 | 0                        | 1    | 1     | 0 | 0                        | 0    | 1     | 0 | 5     | 59               |
| 3:40 PM                               | 0                         | 0    | 0     | 0 | 0                         | 0    | 1     | 0 | 1                        | 2    | 1     | 0 | 0                        | 2    | 0     | 0 | 7     | 56               |
| 3:45 PM                               | 4                         | 0    | 0     | 0 | 0                         | 0    | 2     | 0 | 0                        | 2    | 0     | 0 | 0                        | 0    | 0     | 0 | 8     | 61               |
| 3:50 PM                               | 0                         | 0    | 0     | 0 | 0                         | 0    | 1     | 0 | 1                        | 0    | 1     | 0 | 0                        | 0    | 0     | 0 | 3     | 60               |
| 3:55 PM                               | 1                         | 0    | 0     | 0 | 0                         | 0    | 1     | 0 | 0                        | 0    | 2     | 0 | 0                        | 0    | 0     | 0 | 4     | 61               |
| 4:00 PM                               | 0                         | 0    | 0     | 0 | 0                         | 0    | 0     | 0 | 0                        | 1    | 2     | 0 | 0                        | 2    | 0     | 0 | 5     | 62               |
| 4:05 PM                               | 0                         | 0    | 0     | 0 | 0                         | 0    | 0     | 0 | 2                        | 0    | 0     | 0 | 0                        | 1    | 0     | 0 | 3     | 60               |
| 4:10 PM                               | 1                         | 0    | 0     | 0 | 0                         | 0    | 0     | 0 | 1                        | 0    | 1     | 0 | 0                        | 0    | 0     | 0 | 3     | 62               |
| 4:15 PM                               | 0                         | 0    | 0     | 0 | 0                         | 0    | 0     | 0 | 0                        | 1    | 1     | 0 | 0                        | 1    | 0     | 0 | 3     | 63               |
| 4:20 PM                               | 1                         | 0    | 0     | 0 | 0                         | 0    | 1     | 0 | 1                        | 1    | 1     | 0 | 0                        | 1    | 0     | 0 | 6     | 60               |
| 4:25 PM                               | 0                         | 0    | 0     | 0 | 0                         | 0    | 0     | 0 | 0                        | 1    | 0     | 0 | 0                        | 0    | 0     | 0 | 1     | 57               |
| 4:30 PM                               | 0                         | 0    | 0     | 0 | 1                         | 0    | 0     | 0 | 1                        | 0    | 1     | 0 | 0                        | 0    | 0     | 0 | 3     | 51               |

## Attachment B

| 5-Min Count Period Beginning At | Vivido St (Northbound) |      |       |   | Vivido St (Southbound) |      |       |   | Futuro St (Eastbound) |      |       |   | Futuro St (Westbound) |      |       |   | Total | Hourly Totals |
|---------------------------------|------------------------|------|-------|---|------------------------|------|-------|---|-----------------------|------|-------|---|-----------------------|------|-------|---|-------|---------------|
|                                 | Left                   | Thru | Right | U | Left                   | Thru | Right | U | Left                  | Thru | Right | U | Left                  | Thru | Right | U |       |               |
| 4:35 PM                         | 1                      | 0    | 0     | 0 | 0                      | 0    | 0     | 0 | 2                     | 0    | 0     | 0 | 0                     | 3    | 0     | 0 | 6     | 52            |
| 4:40 PM                         | 0                      | 0    | 0     | 0 | 0                      | 0    | 0     | 0 | 0                     | 1    | 2     | 0 | 0                     | 1    | 0     | 0 | 4     | 49            |
| 4:45 PM                         | 1                      | 0    | 0     | 0 | 0                      | 0    | 1     | 0 | 0                     | 1    | 0     | 0 | 0                     | 1    | 0     | 0 | 4     | 45            |
| 4:50 PM                         | 1                      | 0    | 0     | 0 | 0                      | 0    | 0     | 0 | 0                     | 1    | 1     | 0 | 0                     | 2    | 0     | 0 | 5     | 47            |
| 4:55 PM                         | 0                      | 0    | 0     | 0 | 0                      | 0    | 3     | 0 | 2                     | 0    | 0     | 0 | 0                     | 0    | 0     | 0 | 5     | 48            |
| 5:00 PM                         | 0                      | 0    | 0     | 0 | 0                      | 0    | 0     | 0 | 0                     | 0    | 2     | 0 | 0                     | 1    | 0     | 0 | 3     | 46            |
| 5:05 PM                         | 0                      | 0    | 0     | 0 | 0                      | 0    | 0     | 0 | 3                     | 2    | 3     | 0 | 0                     | 1    | 0     | 0 | 9     | 52            |
| 5:10 PM                         | 1                      | 0    | 0     | 0 | 0                      | 0    | 0     | 0 | 0                     | 1    | 2     | 0 | 0                     | 1    | 0     | 0 | 5     | 54            |
| 5:15 PM                         | 1                      | 0    | 0     | 0 | 0                      | 0    | 0     | 0 | 1                     | 1    | 1     | 0 | 0                     | 1    | 0     | 0 | 5     | 56            |
| 5:20 PM                         | 1                      | 0    | 0     | 0 | 0                      | 1    | 0     | 0 | 2                     | 1    | 0     | 0 | 0                     | 1    | 0     | 0 | 6     | 56            |
| 5:25 PM                         | 0                      | 0    | 1     | 0 | 0                      | 0    | 0     | 0 | 1                     | 1    | 0     | 0 | 0                     | 1    | 0     | 0 | 4     | 59            |
| 5:30 PM                         | 2                      | 0    | 0     | 0 | 0                      | 0    | 1     | 0 | 0                     | 0    | 2     | 0 | 0                     | 0    | 0     | 0 | 5     | 61            |
| 5:35 PM                         | 2                      | 0    | 0     | 0 | 0                      | 0    | 0     | 0 | 1                     | 0    | 1     | 0 | 0                     | 2    | 0     | 0 | 6     | 61            |
| 5:40 PM                         | 1                      | 0    | 0     | 0 | 0                      | 0    | 1     | 0 | 1                     | 0    | 0     | 0 | 0                     | 0    | 0     | 0 | 3     | 60            |
| 5:45 PM                         | 1                      | 0    | 0     | 0 | 0                      | 0    | 1     | 0 | 0                     | 1    | 2     | 0 | 0                     | 1    | 0     | 0 | 6     | 62            |
| 5:50 PM                         | 1                      | 0    | 0     | 0 | 0                      | 0    | 1     | 0 | 2                     | 0    | 1     | 0 | 0                     | 2    | 0     | 0 | 7     | 64            |
| 5:55 PM                         | 1                      | 0    | 0     | 0 | 0                      | 0    | 0     | 0 | 3                     | 0    | 0     | 0 | 0                     | 1    | 0     | 0 | 5     | 64            |
| 6:00 PM                         | 0                      | 0    | 0     | 0 | 0                      | 0    | 0     | 0 | 0                     | 1    | 0     | 0 | 0                     | 0    | 0     | 0 | 1     | 62            |
| 6:05 PM                         | 1                      | 0    | 0     | 0 | 0                      | 1    | 0     | 0 | 1                     | 0    | 2     | 0 | 0                     | 0    | 0     | 0 | 5     | 58            |
| 6:10 PM                         | 0                      | 0    | 1     | 0 | 0                      | 0    | 2     | 0 | 1                     | 1    | 0     | 0 | 0                     | 0    | 0     | 0 | 5     | 58            |
| 6:15 PM                         | 1                      | 0    | 0     | 0 | 0                      | 0    | 1     | 0 | 0                     | 1    | 0     | 0 | 0                     | 3    | 0     | 0 | 6     | 59            |
| 6:20 PM                         | 1                      | 0    | 0     | 0 | 0                      | 0    | 0     | 0 | 1                     | 2    | 0     | 0 | 0                     | 1    | 0     | 0 | 5     | 58            |
| 6:25 PM                         | 0                      | 0    | 0     | 0 | 0                      | 0    | 0     | 0 | 1                     | 0    | 0     | 0 | 0                     | 0    | 0     | 0 | 1     | 55            |
| 6:30 PM                         | 1                      | 0    | 0     | 0 | 0                      | 0    | 1     | 0 | 1                     | 0    | 1     | 0 | 0                     | 0    | 0     | 0 | 4     | 54            |
| 6:35 PM                         | 0                      | 0    | 0     | 0 | 0                      | 0    | 0     | 0 | 2                     | 1    | 0     | 0 | 0                     | 0    | 0     | 0 | 3     | 51            |
| 6:40 PM                         | 0                      | 0    | 0     | 0 | 0                      | 0    | 1     | 0 | 0                     | 1    | 2     | 0 | 0                     | 0    | 0     | 0 | 4     | 52            |
| 6:45 PM                         | 0                      | 0    | 0     | 0 | 0                      | 0    | 0     | 0 | 2                     | 1    | 0     | 0 | 0                     | 0    | 0     | 0 | 3     | 49            |
| 6:50 PM                         | 1                      | 0    | 0     | 0 | 0                      | 0    | 0     | 0 | 0                     | 3    | 1     | 0 | 0                     | 0    | 0     | 0 | 5     | 47            |
| 6:55 PM                         | 1                      | 0    | 0     | 0 | 0                      | 0    | 1     | 0 | 0                     | 0    | 2     | 0 | 0                     | 1    | 0     | 0 | 5     | 47            |
| 7:00 PM                         | 1                      | 0    | 0     | 0 | 0                      | 0    | 1     | 0 | 0                     | 2    | 0     | 0 | 0                     | 1    | 0     | 0 | 5     | 51            |
| 7:05 PM                         | 0                      | 0    | 0     | 0 | 0                      | 0    | 0     | 0 | 0                     | 2    | 1     | 0 | 0                     | 1    | 0     | 0 | 4     | 50            |
| 7:10 PM                         | 0                      | 0    | 0     | 0 | 0                      | 0    | 0     | 0 | 0                     | 0    | 0     | 0 | 1                     | 0    | 0     | 0 | 1     | 46            |
| 7:15 PM                         | 1                      | 0    | 0     | 0 | 0                      | 0    | 0     | 0 | 0                     | 0    | 0     | 0 | 0                     | 0    | 1     | 0 | 2     | 42            |
| 7:20 PM                         | 1                      | 0    | 0     | 0 | 0                      | 0    | 0     | 0 | 2                     | 2    | 1     | 0 | 0                     | 1    | 0     | 0 | 7     | 44            |
| 7:25 PM                         | 0                      | 0    | 0     | 0 | 0                      | 1    | 1     | 0 | 0                     | 0    | 1     | 0 | 0                     | 0    | 0     | 0 | 3     | 46            |
| 7:30 PM                         | 3                      | 0    | 0     | 0 | 0                      | 0    | 1     | 0 | 1                     | 0    | 1     | 0 | 0                     | 0    | 0     | 0 | 6     | 48            |
| 7:35 PM                         | 0                      | 0    | 0     | 0 | 0                      | 0    | 0     | 0 | 0                     | 2    | 0     | 0 | 0                     | 0    | 0     | 0 | 2     | 47            |
| 7:40 PM                         | 0                      | 0    | 0     | 0 | 0                      | 0    | 0     | 0 | 0                     | 0    | 1     | 0 | 0                     | 1    | 0     | 0 | 2     | 45            |
| 7:45 PM                         | 0                      | 0    | 0     | 0 | 0                      | 0    | 0     | 0 | 0                     | 0    | 1     | 0 | 0                     | 1    | 0     | 0 | 2     | 44            |
| 7:50 PM                         | 0                      | 0    | 0     | 0 | 0                      | 0    | 0     | 0 | 1                     | 0    | 1     | 0 | 0                     | 0    | 0     | 0 | 2     | 41            |
| 7:55 PM                         | 1                      | 0    | 0     | 0 | 0                      | 0    | 0     | 0 | 0                     | 1    | 0     | 0 | 0                     | 0    | 0     | 0 | 2     | 38            |
| 8:00 PM                         | 0                      | 0    | 0     | 0 | 0                      | 0    | 0     | 0 | 0                     | 1    | 0     | 0 | 0                     | 0    | 0     | 0 | 1     | 34            |
| 8:05 PM                         | 0                      | 0    | 0     | 0 | 0                      | 0    | 0     | 0 | 0                     | 0    | 1     | 0 | 0                     | 0    | 0     | 0 | 1     | 31            |
| 8:10 PM                         | 0                      | 0    | 0     | 0 | 0                      | 0    | 0     | 0 | 0                     | 0    | 0     | 0 | 0                     | 0    | 0     | 0 | 0     | 30            |
| 8:15 PM                         | 0                      | 0    | 0     | 0 | 0                      | 0    | 0     | 0 | 0                     | 1    | 0     | 0 | 0                     | 0    | 0     | 0 | 1     | 29            |
| 8:20 PM                         | 1                      | 0    | 0     | 0 | 0                      | 0    | 0     | 0 | 1                     | 0    | 2     | 0 | 0                     | 0    | 0     | 0 | 4     | 26            |
| 8:25 PM                         | 1                      | 0    | 0     | 0 | 0                      | 0    | 0     | 0 | 1                     | 0    | 1     | 0 | 0                     | 0    | 0     | 0 | 3     | 26            |
| 8:30 PM                         | 0                      | 0    | 0     | 0 | 0                      | 0    | 0     | 0 | 1                     | 2    | 2     | 0 | 0                     | 0    | 0     | 0 | 5     | 25            |
| 8:35 PM                         | 0                      | 0    | 0     | 0 | 0                      | 0    | 0     | 0 | 0                     | 0    | 0     | 0 | 0                     | 0    | 0     | 0 | 0     | 23            |
| 8:40 PM                         | 0                      | 0    | 0     | 0 | 0                      | 0    | 0     | 0 | 0                     | 0    | 2     | 0 | 0                     | 0    | 0     | 0 | 2     | 23            |
| 8:45 PM                         | 0                      | 0    | 0     | 0 | 0                      | 0    | 0     | 0 | 0                     | 0    | 1     | 0 | 0                     | 0    | 0     | 0 | 1     | 22            |
| 8:50 PM                         | 1                      | 0    | 0     | 0 | 0                      | 0    | 0     | 0 | 0                     | 0    | 0     | 0 | 0                     | 0    | 0     | 0 | 1     | 21            |
| 8:55 PM                         | 0                      | 0    | 0     | 0 | 0                      | 0    | 0     | 0 | 0                     | 2    | 0     | 0 | 0                     | 0    | 0     | 0 | 2     | 21            |
| 9:00 PM                         | 0                      | 0    | 0     | 0 | 0                      | 0    | 0     | 0 | 0                     | 0    | 0     | 0 | 0                     | 0    | 0     | 0 | 0     | 20            |
| 9:05 PM                         | 0                      | 0    | 0     | 0 | 0                      | 0    | 0     | 0 | 0                     | 0    | 0     | 0 | 0                     | 0    | 0     | 0 | 0     | 19            |
| 9:10 PM                         | 0                      | 0    | 0     | 0 | 0                      | 0    | 0     | 0 | 0                     | 0    | 0     | 0 | 0                     | 0    | 0     | 0 | 0     | 19            |
| 9:15 PM                         | 0                      | 0    | 0     | 0 | 0                      | 0    | 0     | 0 | 0                     | 0    | 0     | 0 | 0                     | 0    | 0     | 0 | 0     | 18            |
| 9:20 PM                         | 0                      | 0    | 0     | 0 | 0                      | 0    | 0     | 0 | 2                     | 0    | 0     | 0 | 0                     | 0    | 0     | 0 | 2     | 16            |
| 9:25 PM                         | 0                      | 0    | 0     | 0 | 0                      | 0    | 1     | 0 | 0                     | 0    | 0     | 0 | 0                     | 0    | 0     | 0 | 1     | 14            |
| 9:30 PM                         | 0                      | 0    | 0     | 0 | 0                      | 0    | 0     | 0 | 0                     | 0    | 0     | 0 | 0                     | 0    | 0     | 0 | 0     | 9             |
| 9:35 PM                         | 0                      | 0    | 0     | 0 | 0                      | 0    | 0     | 0 | 0                     | 0    | 0     | 0 | 0                     | 0    | 0     | 0 | 0     | 9             |
| 9:40 PM                         | 1                      | 0    | 0     | 0 | 0                      | 0    | 0     | 0 | 0                     | 0    | 0     | 0 | 0                     | 0    | 0     | 0 | 1     | 8             |
| 9:45 PM                         | 0                      | 0    | 0     | 0 | 0                      | 0    | 0     | 0 | 0                     | 1    | 0     | 0 | 0                     | 0    | 0     | 0 | 1     | 8             |
| 9:50 PM                         | 0                      | 0    | 0     | 0 | 0                      | 0    | 0     | 0 | 1                     | 0    | 0     | 0 | 0                     | 0    | 0     | 0 | 1     | 8             |
| 9:55 PM                         | 0                      | 0    | 0     | 0 | 0                      | 0    | 0     | 0 | 0                     | 0    | 0     | 0 | 0                     | 0    | 0     | 0 | 0     | 6             |
| Peak 15-Min Flowrates           | Northbound             |      |       |   | Southbound             |      |       |   | Eastbound             |      |       |   | Westbound             |      |       |   | Total |               |
|                                 | Left                   | Thru | Right | U | Left                   | Thru | Right | U | Left                  | Thru | Right | U | Left                  | Thru | Right | U |       |               |
| All Vehicles                    | 28                     | 0    | 0     | 0 | 0                      | 0    | 20    | 0 | 4                     | 8    | 0     | 0 | 0                     | 24   | 0     | 0 | 84    |               |
| Heavy Trucks                    | 0                      | 0    | 0     |   | 0                      | 0    | 0     |   | 0                     | 0    | 0     |   | 0                     | 0    | 0     |   | 0     |               |
| Buses                           |                        |      |       |   |                        |      |       |   |                       |      |       |   |                       |      |       |   |       |               |
| Pedestrians                     |                        | 0    |       |   |                        | 0    |       |   |                       | 4    |       |   |                       | 0    |       |   | 4     |               |
| Bicycles                        | 0                      | 0    | 0     |   | 0                      | 0    | 0     |   | 0                     | 0    | 0     |   | 0                     | 0    | 0     |   | 0     |               |
| Scoters                         |                        |      |       |   |                        |      |       |   |                       |      |       |   |                       |      |       |   |       |               |

Comments:

LOCATION: Maybeck Ln -- Dawnwood  
 CITY/STATE: Ladera Ranch, CA

QC JOB #: 16966468  
 DATE: Wed, Apr 16 2025

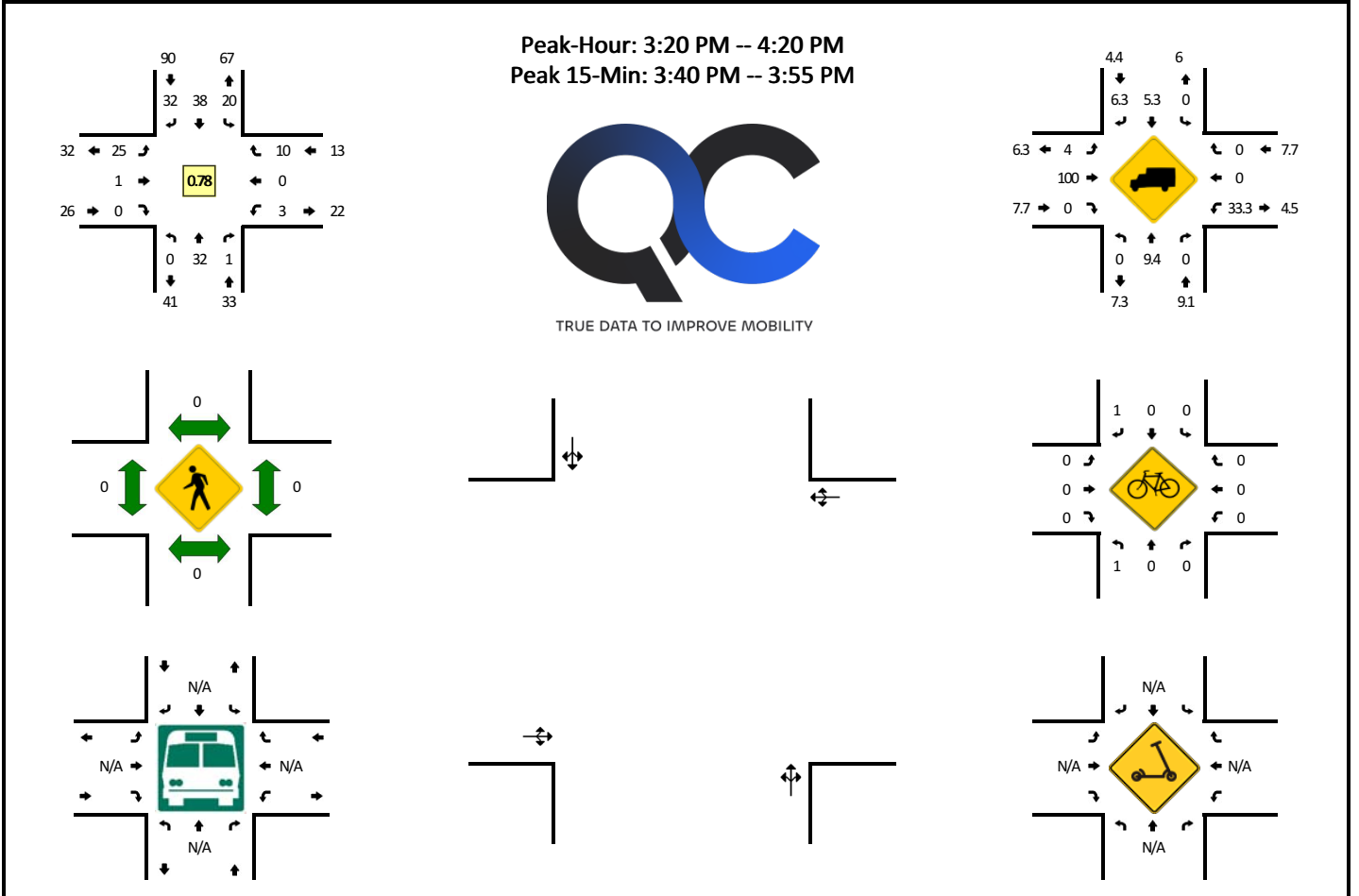

| 5-Min Count Period Beginning At | Maybeck Ln (Northbound) |      |       |   | Maybeck Ln (Southbound) |      |       |   | Dawnwood (Eastbound) |      |       |   | Dawnwood (Westbound) |      |       |   | Total | Hourly Totals |
|---------------------------------|-------------------------|------|-------|---|-------------------------|------|-------|---|----------------------|------|-------|---|----------------------|------|-------|---|-------|---------------|
|                                 | Left                    | Thru | Right | U | Left                    | Thru | Right | U | Left                 | Thru | Right | U | Left                 | Thru | Right | U |       |               |
| 6:00 AM                         | 0                       | 1    | 0     | 0 | 0                       | 0    | 0     | 0 | 1                    | 0    | 0     | 0 | 0                    | 0    | 0     | 0 | 2     |               |
| 6:05 AM                         | 0                       | 1    | 0     | 0 | 0                       | 0    | 0     | 0 | 0                    | 0    | 0     | 0 | 0                    | 0    | 0     | 0 | 1     |               |
| 6:10 AM                         | 0                       | 1    | 0     | 0 | 0                       | 0    | 0     | 0 | 4                    | 0    | 0     | 0 | 0                    | 0    | 0     | 0 | 5     |               |
| 6:15 AM                         | 0                       | 0    | 0     | 0 | 0                       | 0    | 0     | 0 | 1                    | 0    | 0     | 0 | 0                    | 0    | 1     | 0 | 2     |               |
| 6:20 AM                         | 0                       | 2    | 0     | 0 | 0                       | 1    | 1     | 0 | 1                    | 0    | 0     | 0 | 0                    | 0    | 1     | 0 | 6     |               |
| 6:25 AM                         | 0                       | 0    | 0     | 0 | 0                       | 0    | 0     | 0 | 0                    | 0    | 0     | 0 | 0                    | 0    | 1     | 0 | 1     |               |
| 6:30 AM                         | 0                       | 1    | 0     | 0 | 0                       | 0    | 0     | 0 | 1                    | 0    | 0     | 0 | 0                    | 0    | 1     | 0 | 3     |               |
| 6:35 AM                         | 0                       | 1    | 0     | 0 | 0                       | 0    | 1     | 0 | 1                    | 0    | 0     | 0 | 0                    | 0    | 0     | 0 | 3     |               |
| 6:40 AM                         | 0                       | 1    | 0     | 0 | 0                       | 0    | 1     | 0 | 0                    | 0    | 0     | 0 | 0                    | 0    | 0     | 0 | 2     |               |
| 6:45 AM                         | 0                       | 2    | 0     | 0 | 0                       | 3    | 1     | 0 | 1                    | 0    | 0     | 0 | 0                    | 0    | 2     | 0 | 9     |               |
| 6:50 AM                         | 0                       | 4    | 0     | 0 | 0                       | 0    | 1     | 0 | 1                    | 0    | 0     | 0 | 0                    | 0    | 2     | 0 | 8     |               |
| 6:55 AM                         | 0                       | 5    | 0     | 0 | 0                       | 1    | 0     | 0 | 2                    | 0    | 0     | 0 | 0                    | 0    | 0     | 0 | 8     | 50            |
| 7:00 AM                         | 0                       | 2    | 0     | 0 | 2                       | 0    | 0     | 0 | 0                    | 0    | 0     | 0 | 0                    | 0    | 2     | 0 | 6     | 54            |
| 7:05 AM                         | 0                       | 6    | 0     | 0 | 0                       | 0    | 2     | 0 | 1                    | 0    | 1     | 0 | 0                    | 0    | 3     | 0 | 13    | 66            |
| 7:10 AM                         | 0                       | 2    | 0     | 0 | 0                       | 1    | 0     | 0 | 3                    | 0    | 0     | 0 | 0                    | 0    | 1     | 0 | 7     | 68            |
| 7:15 AM                         | 0                       | 2    | 0     | 0 | 0                       | 0    | 0     | 0 | 2                    | 0    | 0     | 0 | 0                    | 0    | 1     | 0 | 5     | 71            |
| 7:20 AM                         | 0                       | 2    | 0     | 0 | 2                       | 0    | 0     | 0 | 0                    | 0    | 0     | 0 | 0                    | 0    | 1     | 0 | 5     | 70            |
| 7:25 AM                         | 0                       | 1    | 0     | 0 | 1                       | 0    | 1     | 0 | 3                    | 0    | 0     | 0 | 0                    | 0    | 3     | 0 | 9     | 78            |
| 7:30 AM                         | 0                       | 3    | 0     | 0 | 0                       | 2    | 2     | 0 | 4                    | 0    | 0     | 0 | 0                    | 0    | 2     | 0 | 13    | 88            |
| 7:35 AM                         | 0                       | 4    | 0     | 0 | 1                       | 1    | 2     | 0 | 6                    | 0    | 0     | 0 | 0                    | 0    | 1     | 0 | 15    | 100           |
| 7:40 AM                         | 0                       | 2    | 0     | 0 | 0                       | 1    | 2     | 0 | 7                    | 0    | 0     | 0 | 0                    | 0    | 2     | 0 | 14    | 112           |
| 7:45 AM                         | 0                       | 8    | 0     | 0 | 1                       | 1    | 2     | 0 | 7                    | 0    | 0     | 0 | 0                    | 0    | 3     | 0 | 22    | 125           |
| 7:50 AM                         | 0                       | 8    | 0     | 0 | 1                       | 1    | 1     | 0 | 3                    | 1    | 0     | 0 | 0                    | 0    | 1     | 0 | 16    | 133           |
| 7:55 AM                         | 0                       | 2    | 0     | 0 | 0                       | 4    | 1     | 0 | 2                    | 1    | 0     | 0 | 0                    | 0    | 5     | 0 | 15    | 140           |
| 8:00 AM                         | 0                       | 2    | 0     | 0 | 2                       | 0    | 3     | 0 | 3                    | 0    | 0     | 0 | 0                    | 0    | 3     | 0 | 13    | 147           |
| 8:05 AM                         | 0                       | 4    | 0     | 0 | 0                       | 2    | 5     | 0 | 5                    | 0    | 0     | 0 | 0                    | 0    | 0     | 0 | 16    | 150           |
| 8:10 AM                         | 0                       | 1    | 0     | 0 | 2                       | 1    | 1     | 0 | 1                    | 0    | 0     | 0 | 0                    | 0    | 0     | 0 | 6     | 149           |
| 8:15 AM                         | 0                       | 1    | 0     | 0 | 0                       | 1    | 1     | 0 | 0                    | 0    | 0     | 0 | 1                    | 0    | 1     | 0 | 5     | 149           |
| 8:20 AM                         | 0                       | 2    | 0     | 0 | 0                       | 2    | 3     | 0 | 2                    | 0    | 0     | 0 | 0                    | 0    | 6     | 0 | 15    | 159           |
| 8:25 AM                         | 0                       | 3    | 0     | 0 | 0                       | 2    | 3     | 0 | 2                    | 0    | 0     | 0 | 0                    | 0    | 1     | 0 | 11    | 161           |
| 8:30 AM                         | 0                       | 2    | 0     | 0 | 4                       | 1    | 0     | 0 | 5                    | 0    | 0     | 0 | 0                    | 0    | 1     | 0 | 13    | 161           |
| 8:35 AM                         | 0                       | 1    | 0     | 0 | 0                       | 1    | 1     | 0 | 1                    | 0    | 0     | 0 | 0                    | 0    | 1     | 0 | 5     | 151           |
| 8:40 AM                         | 0                       | 2    | 0     | 0 | 4                       | 0    | 0     | 0 | 1                    | 0    | 0     | 0 | 0                    | 0    | 1     | 0 | 8     | 145           |
| 8:45 AM                         | 0                       | 2    | 0     | 0 | 0                       | 0    | 2     | 0 | 3                    | 0    | 0     | 0 | 0                    | 0    | 1     | 0 | 8     | 131           |
| 8:50 AM                         | 0                       | 2    | 0     | 0 | 0                       | 1    | 1     | 0 | 4                    | 0    | 0     | 0 | 0                    | 0    | 0     | 0 | 8     | 123           |
| 8:55 AM                         | 0                       | 0    | 0     | 0 | 0                       | 0    | 2     | 0 | 3                    | 0    | 0     | 0 | 0                    | 0    | 1     | 0 | 6     | 114           |
| 9:00 AM                         | 0                       | 1    | 0     | 0 | 0                       | 0    | 0     | 0 | 4                    | 0    | 0     | 0 | 0                    | 0    | 1     | 0 | 6     | 107           |
| 9:05 AM                         | 0                       | 0    | 0     | 0 | 1                       | 0    | 2     | 0 | 1                    | 0    | 0     | 0 | 0                    | 0    | 4     | 0 | 8     | 99            |

Attachment B

| 5-Min Count Period Beginning At | Maybeck Ln (Northbound) |      |       |   | Maybeck Ln (Southbound) |      |       |   | Dawnwood (Eastbound) |      |       |   | Dawnwood (Westbound) |      |       |   | Total | Hourly Totals |
|---------------------------------|-------------------------|------|-------|---|-------------------------|------|-------|---|----------------------|------|-------|---|----------------------|------|-------|---|-------|---------------|
|                                 | Left                    | Thru | Right | U | Left                    | Thru | Right | U | Left                 | Thru | Right | U | Left                 | Thru | Right | U |       |               |
| 9:10 AM                         | 0                       | 0    | 0     | 0 | 1                       | 0    | 0     | 0 | 1                    | 0    | 0     | 0 | 0                    | 0    | 0     | 0 | 2     | 95            |
| 9:15 AM                         | 0                       | 3    | 0     | 0 | 0                       | 1    | 1     | 0 | 1                    | 0    | 0     | 0 | 0                    | 0    | 0     | 0 | 6     | 96            |
| 9:20 AM                         | 0                       | 3    | 0     | 0 | 1                       | 2    | 0     | 0 | 2                    | 0    | 0     | 0 | 0                    | 0    | 0     | 0 | 8     | 89            |
| 9:25 AM                         | 0                       | 1    | 0     | 0 | 0                       | 1    | 1     | 0 | 2                    | 0    | 0     | 0 | 0                    | 0    | 0     | 0 | 5     | 83            |
| 9:30 AM                         | 0                       | 0    | 0     | 0 | 0                       | 0    | 1     | 0 | 1                    | 0    | 0     | 0 | 0                    | 0    | 2     | 0 | 4     | 74            |
| 9:35 AM                         | 0                       | 0    | 1     | 0 | 2                       | 1    | 1     | 0 | 0                    | 0    | 1     | 0 | 0                    | 0    | 0     | 0 | 6     | 75            |
| 9:40 AM                         | 0                       | 3    | 0     | 0 | 0                       | 0    | 2     | 0 | 1                    | 0    | 0     | 0 | 0                    | 0    | 0     | 0 | 6     | 73            |
| 9:45 AM                         | 0                       | 1    | 0     | 0 | 0                       | 0    | 2     | 0 | 1                    | 0    | 0     | 0 | 0                    | 0    | 1     | 0 | 5     | 70            |
| 9:50 AM                         | 0                       | 1    | 1     | 0 | 0                       | 0    | 3     | 0 | 2                    | 0    | 0     | 0 | 0                    | 0    | 3     | 0 | 10    | 72            |
| 9:55 AM                         | 0                       | 1    | 0     | 0 | 0                       | 1    | 0     | 0 | 1                    | 0    | 0     | 0 | 0                    | 0    | 4     | 0 | 7     | 73            |
| 10:00 AM                        | 0                       | 2    | 0     | 0 | 0                       | 0    | 0     | 0 | 1                    | 0    | 0     | 0 | 0                    | 0    | 2     | 0 | 5     | 72            |
| 10:05 AM                        | 0                       | 0    | 0     | 0 | 1                       | 1    | 2     | 0 | 3                    | 0    | 1     | 0 | 0                    | 0    | 0     | 0 | 8     | 72            |
| 10:10 AM                        | 0                       | 1    | 0     | 0 | 0                       | 2    | 1     | 0 | 2                    | 0    | 0     | 0 | 0                    | 0    | 2     | 0 | 8     | 78            |
| 10:15 AM                        | 0                       | 1    | 0     | 0 | 0                       | 0    | 2     | 0 | 1                    | 0    | 0     | 0 | 0                    | 0    | 1     | 0 | 5     | 77            |
| 10:20 AM                        | 0                       | 0    | 0     | 0 | 2                       | 0    | 1     | 0 | 0                    | 0    | 0     | 0 | 0                    | 0    | 2     | 0 | 5     | 74            |
| 10:25 AM                        | 0                       | 1    | 1     | 0 | 1                       | 1    | 1     | 0 | 2                    | 0    | 0     | 0 | 0                    | 0    | 0     | 0 | 7     | 76            |
| 10:30 AM                        | 0                       | 1    | 0     | 0 | 0                       | 0    | 1     | 0 | 0                    | 0    | 0     | 0 | 0                    | 0    | 0     | 0 | 2     | 74            |
| 10:35 AM                        | 0                       | 0    | 0     | 0 | 1                       | 0    | 0     | 0 | 1                    | 0    | 0     | 0 | 0                    | 0    | 2     | 0 | 4     | 72            |
| 10:40 AM                        | 0                       | 0    | 0     | 0 | 0                       | 3    | 0     | 0 | 1                    | 0    | 0     | 0 | 0                    | 0    | 2     | 0 | 6     | 72            |
| 10:45 AM                        | 0                       | 1    | 0     | 0 | 0                       | 0    | 2     | 0 | 0                    | 0    | 0     | 0 | 0                    | 0    | 0     | 0 | 3     | 70            |
| 10:50 AM                        | 0                       | 0    | 0     | 0 | 1                       | 0    | 1     | 0 | 2                    | 0    | 0     | 0 | 0                    | 0    | 1     | 0 | 5     | 65            |
| 10:55 AM                        | 0                       | 1    | 0     | 0 | 0                       | 2    | 0     | 0 | 2                    | 0    | 0     | 0 | 0                    | 0    | 0     | 0 | 5     | 63            |
| 11:00 AM                        | 0                       | 1    | 0     | 0 | 1                       | 1    | 0     | 0 | 1                    | 0    | 0     | 0 | 0                    | 0    | 2     | 0 | 6     | 64            |
| 11:05 AM                        | 0                       | 0    | 0     | 0 | 1                       | 1    | 0     | 0 | 0                    | 0    | 0     | 0 | 0                    | 0    | 1     | 0 | 3     | 59            |
| 11:10 AM                        | 0                       | 0    | 0     | 0 | 0                       | 0    | 1     | 0 | 1                    | 0    | 0     | 0 | 0                    | 0    | 1     | 0 | 3     | 54            |
| 11:15 AM                        | 0                       | 2    | 0     | 0 | 1                       | 0    | 1     | 0 | 1                    | 0    | 0     | 0 | 0                    | 0    | 2     | 0 | 7     | 56            |
| 11:20 AM                        | 0                       | 2    | 0     | 0 | 0                       | 1    | 0     | 0 | 0                    | 0    | 0     | 0 | 0                    | 0    | 0     | 0 | 3     | 54            |
| 11:25 AM                        | 0                       | 0    | 0     | 0 | 1                       | 0    | 1     | 0 | 2                    | 0    | 0     | 0 | 0                    | 0    | 1     | 0 | 5     | 52            |
| 11:30 AM                        | 0                       | 2    | 0     | 0 | 3                       | 2    | 2     | 0 | 0                    | 0    | 0     | 0 | 0                    | 0    | 4     | 0 | 13    | 63            |
| 11:35 AM                        | 0                       | 0    | 0     | 0 | 1                       | 5    | 1     | 0 | 2                    | 0    | 0     | 0 | 0                    | 0    | 1     | 0 | 10    | 69            |
| 11:40 AM                        | 0                       | 0    | 0     | 0 | 1                       | 1    | 2     | 0 | 1                    | 0    | 0     | 0 | 0                    | 0    | 0     | 0 | 5     | 68            |
| 11:45 AM                        | 0                       | 1    | 0     | 0 | 1                       | 2    | 1     | 0 | 3                    | 0    | 0     | 0 | 0                    | 0    | 1     | 0 | 9     | 74            |
| 11:50 AM                        | 1                       | 3    | 0     | 0 | 2                       | 1    | 0     | 0 | 1                    | 0    | 0     | 0 | 0                    | 0    | 2     | 0 | 10    | 79            |
| 11:55 AM                        | 0                       | 2    | 0     | 0 | 1                       | 1    | 3     | 0 | 0                    | 1    | 0     | 0 | 0                    | 0    | 0     | 0 | 8     | 82            |
| 12:00 PM                        | 0                       | 1    | 0     | 0 | 1                       | 1    | 3     | 0 | 4                    | 0    | 0     | 0 | 0                    | 0    | 0     | 0 | 10    | 86            |
| 12:05 PM                        | 0                       | 0    | 0     | 0 | 0                       | 1    | 0     | 0 | 0                    | 0    | 0     | 0 | 0                    | 0    | 1     | 0 | 2     | 85            |
| 12:10 PM                        | 0                       | 2    | 0     | 0 | 1                       | 1    | 0     | 0 | 1                    | 0    | 0     | 0 | 0                    | 0    | 2     | 0 | 7     | 89            |
| 12:15 PM                        | 0                       | 1    | 0     | 0 | 1                       | 1    | 3     | 0 | 0                    | 0    | 0     | 0 | 0                    | 0    | 0     | 0 | 6     | 88            |
| 12:20 PM                        | 0                       | 1    | 0     | 0 | 1                       | 1    | 1     | 0 | 1                    | 0    | 0     | 0 | 0                    | 0    | 0     | 0 | 5     | 90            |
| 12:25 PM                        | 0                       | 1    | 0     | 0 | 0                       | 0    | 1     | 0 | 2                    | 0    | 0     | 0 | 0                    | 0    | 0     | 0 | 4     | 89            |
| 12:30 PM                        | 0                       | 2    | 0     | 0 | 1                       | 3    | 0     | 0 | 2                    | 0    | 0     | 0 | 0                    | 0    | 2     | 0 | 10    | 86            |
| 12:35 PM                        | 0                       | 1    | 0     | 0 | 2                       | 1    | 1     | 0 | 1                    | 0    | 0     | 0 | 0                    | 0    | 2     | 0 | 8     | 84            |
| 12:40 PM                        | 0                       | 1    | 0     | 0 | 1                       | 1    | 1     | 0 | 1                    | 0    | 0     | 0 | 0                    | 0    | 0     | 0 | 5     | 84            |
| 12:45 PM                        | 0                       | 0    | 0     | 0 | 0                       | 3    | 0     | 0 | 1                    | 0    | 0     | 0 | 0                    | 0    | 2     | 0 | 6     | 81            |
| 12:50 PM                        | 0                       | 3    | 0     | 0 | 0                       | 0    | 0     | 0 | 1                    | 0    | 0     | 0 | 0                    | 0    | 2     | 0 | 6     | 77            |
| 12:55 PM                        | 0                       | 1    | 0     | 0 | 0                       | 2    | 0     | 0 | 2                    | 0    | 0     | 0 | 0                    | 0    | 1     | 0 | 6     | 75            |
| 1:00 PM                         | 0                       | 1    | 0     | 0 | 1                       | 1    | 3     | 0 | 1                    | 0    | 0     | 0 | 0                    | 0    | 0     | 0 | 7     | 72            |
| 1:05 PM                         | 0                       | 3    | 0     | 0 | 0                       | 1    | 2     | 0 | 2                    | 0    | 0     | 0 | 0                    | 0    | 0     | 0 | 8     | 78            |
| 1:10 PM                         | 0                       | 1    | 0     | 0 | 4                       | 3    | 2     | 0 | 1                    | 0    | 0     | 0 | 0                    | 0    | 1     | 0 | 12    | 83            |
| 1:15 PM                         | 0                       | 1    | 0     | 0 | 2                       | 4    | 4     | 0 | 1                    | 0    | 0     | 0 | 0                    | 0    | 1     | 0 | 13    | 90            |
| 1:20 PM                         | 1                       | 2    | 0     | 0 | 1                       | 1    | 4     | 0 | 0                    | 1    | 0     | 0 | 1                    | 0    | 2     | 0 | 13    | 98            |
| 1:25 PM                         | 1                       | 2    | 0     | 0 | 2                       | 1    | 5     | 0 | 3                    | 0    | 0     | 0 | 0                    | 0    | 1     | 0 | 15    | 109           |
| 1:30 PM                         | 0                       | 2    | 0     | 0 | 1                       | 1    | 1     | 0 | 8                    | 0    | 0     | 0 | 0                    | 0    | 1     | 0 | 14    | 113           |
| 1:35 PM                         | 0                       | 0    | 0     | 0 | 0                       | 0    | 0     | 0 | 2                    | 0    | 0     | 0 | 0                    | 0    | 0     | 0 | 2     | 107           |
| 1:40 PM                         | 0                       | 0    | 0     | 0 | 3                       | 1    | 3     | 0 | 1                    | 0    | 0     | 0 | 0                    | 0    | 1     | 0 | 9     | 111           |
| 1:45 PM                         | 0                       | 2    | 0     | 0 | 3                       | 1    | 1     | 0 | 4                    | 1    | 0     | 0 | 0                    | 0    | 1     | 0 | 13    | 118           |
| 1:50 PM                         | 0                       | 0    | 0     | 0 | 2                       | 2    | 1     | 0 | 1                    | 0    | 0     | 0 | 0                    | 0    | 1     | 0 | 7     | 119           |
| 1:55 PM                         | 0                       | 1    | 0     | 0 | 1                       | 3    | 3     | 0 | 0                    | 0    | 0     | 0 | 1                    | 0    | 0     | 0 | 9     | 122           |
| 2:00 PM                         | 0                       | 0    | 0     | 0 | 1                       | 1    | 0     | 0 | 3                    | 0    | 0     | 0 | 0                    | 0    | 1     | 0 | 6     | 121           |
| 2:05 PM                         | 0                       | 0    | 0     | 0 | 2                       | 2    | 5     | 0 | 2                    | 0    | 0     | 0 | 0                    | 0    | 0     | 0 | 11    | 124           |
| 2:10 PM                         | 0                       | 1    | 0     | 0 | 0                       | 0    | 0     | 0 | 1                    | 0    | 1     | 0 | 0                    | 0    | 0     | 0 | 3     | 115           |
| 2:15 PM                         | 0                       | 1    | 0     | 0 | 0                       | 1    | 5     | 0 | 3                    | 1    | 0     | 0 | 0                    | 0    | 1     | 0 | 12    | 114           |
| 2:20 PM                         | 0                       | 3    | 1     | 0 | 4                       | 2    | 3     | 0 | 2                    | 0    | 0     | 0 | 1                    | 0    | 4     | 0 | 20    | 121           |
| 2:25 PM                         | 0                       | 3    | 0     | 0 | 0                       | 2    | 1     | 0 | 0                    | 0    | 0     | 0 | 0                    | 0    | 2     | 0 | 8     | 114           |
| 2:30 PM                         | 0                       | 0    | 0     | 0 | 1                       | 2    | 1     | 0 | 4                    | 0    | 0     | 0 | 0                    | 0    | 0     | 0 | 8     | 108           |
| 2:35 PM                         | 0                       | 2    | 1     | 0 | 3                       | 1    | 3     | 0 | 1                    | 0    | 0     | 0 | 0                    | 0    | 2     | 0 | 13    | 119           |
| 2:40 PM                         | 0                       | 1    | 0     | 0 | 1                       | 6    | 1     | 0 | 2                    | 0    | 0     | 0 | 0                    | 0    | 2     | 0 | 13    | 123           |
| 2:45 PM                         | 0                       | 3    | 0     | 0 | 2                       | 2    | 1     | 0 | 3                    | 0    | 0     | 0 | 0                    | 0    | 1     | 0 | 12    | 122           |
| 2:50 PM                         | 0                       | 1    | 0     | 0 | 2                       | 2    | 0     | 0 | 0                    | 0    | 0     | 0 | 0                    | 0    | 1     | 0 | 6     | 121           |
| 2:55 PM                         | 0                       | 3    | 0     | 0 | 4                       | 1    | 2     | 0 | 2                    | 0    | 0     | 0 | 0                    | 0    | 2     | 0 | 14    | 126           |
| 3:00 PM                         | 0                       | 1    | 0     | 0 | 1                       | 4    | 0     | 0 | 0                    | 0    | 0     | 0 | 0                    | 0    | 1     | 0 | 7     | 127           |
| 3:05 PM                         | 0                       | 3    | 0     | 0 | 1                       | 3    | 2     | 0 | 4                    | 0    | 0     | 0 | 0                    | 0    | 3     | 0 | 16    | 132           |
| 3:10 PM                         | 0                       | 2    | 0     | 0 | 4                       | 2    | 1     | 0 | 1                    | 0    | 0     | 0 | 0                    | 0    | 1     | 0 | 11    | 140           |
| 3:15 PM                         | 0                       | 1    | 0     | 0 | 0                       | 0    | 6     | 0 | 1                    | 0    | 1     | 0 | 0                    | 0    | 0     | 0 | 9     | 137           |
| 3:20 PM                         | 0                       | 4    | 0     | 0 | 0                       | 3    | 1     | 0 | 4                    | 0    | 0     | 0 | 0                    | 0    | 3     | 0 | 15    | 132           |
| 3:25 PM                         | 0                       | 2    | 0     | 0 | 2                       | 4    | 1     | 0 | 1                    | 0    | 0     | 0 | 0                    | 0    | 1     | 0 | 11    | 135           |
| 3:30 PM                         | 0                       | 2    | 0     | 0 | 1                       | 6    | 1     | 0 | 2                    | 0    | 0     | 0 | 0                    | 0    | 0     | 0 | 12    | 139           |
| 3:35 PM                         | 0                       | 3    | 0     | 0 | 1                       | 2    | 2     | 0 | 2                    | 0    | 0     | 0 | 0                    | 0    | 1     | 0 | 11    | 137           |
| 3:40 PM                         | 0                       | 0    | 1     | 0 | 2                       | 4    | 5     | 0 | 2                    | 0    | 0     | 0 | 2                    | 0    | 0     | 0 | 16    | 140           |
| 3:45 PM                         | 0                       | 3    | 0     | 0 | 2                       | 3    | 4     | 0 | 2                    | 0    | 0     | 0 | 0                    | 0    | 0     | 0 | 14    | 142           |
| 3:50 PM                         | 0                       | 3    | 0     | 0 | 3                       | 4    | 5     | 0 | 4                    | 0    | 0     | 0 | 0                    | 0    | 3     | 0 | 22    | 158           |
| 3:55 PM                         | 0                       | 3    | 0     | 0 | 1                       | 1    | 5     | 0 | 1                    | 0    | 0     | 0 | 0                    | 0    | 0     | 0 | 11    | 155           |
| 4:00 PM                         | 0                       | 1    | 0     | 0 | 1                       | 2    | 3     | 0 | 2                    | 1    | 0     | 0 | 0                    | 0    | 1     | 0 | 11    | 159           |
| 4:05 PM                         | 0                       | 7    | 0     | 0 | 3                       | 4    | 0     | 0 | 3                    | 0    | 0     | 0 | 1                    | 0    | 0     | 0 | 18    | 161           |
| 4:10 PM                         | 0                       | 4    | 0     | 0 | 1                       | 1    | 3     | 0 | 0                    | 0    | 0     | 0 | 0                    | 0    | 1     | 0 | 10    | 160           |
| 4:15 PM                         | 0                       | 0    | 0     | 0 | 3                       | 4    | 2     | 0 | 2                    | 0    | 0     | 0 | 0                    | 0    | 0     | 0 | 11    | 162           |
| 4:20 PM                         | 0                       | 2    | 0     | 0 | 1                       | 0    | 5     | 0 | 1                    | 0    | 0     | 0 | 0                    | 0    | 0     | 0 | 9     | 156           |
| 4:25 PM                         | 0                       | 1    | 0     | 0 | 2                       | 0    | 3     | 0 | 2                    | 0    | 0     | 0 | 0                    | 0    | 1     | 0 | 9     | 154           |

**Attachment B**

| 5-Min Count Period Beginning At | Maybeck Ln (Northbound) |      |       |   | Maybeck Ln (Southbound) |      |       |   | Dawnwood (Eastbound) |      |       |   | Dawnwood (Westbound) |      |       |   | Total | Hourly Totals |
|---------------------------------|-------------------------|------|-------|---|-------------------------|------|-------|---|----------------------|------|-------|---|----------------------|------|-------|---|-------|---------------|
|                                 | Left                    | Thru | Right | U | Left                    | Thru | Right | U | Left                 | Thru | Right | U | Left                 | Thru | Right | U |       |               |
| 4:30 PM                         | 0                       | 0    | 0     | 0 | 0                       | 1    | 4     | 0 | 2                    | 0    | 0     | 0 | 0                    | 0    | 4     | 0 | 11    | 153           |
| 4:35 PM                         | 0                       | 4    | 0     | 0 | 1                       | 0    | 5     | 0 | 2                    | 0    | 0     | 0 | 0                    | 0    | 2     | 0 | 14    | 156           |
| 4:40 PM                         | 0                       | 2    | 0     | 0 | 0                       | 2    | 3     | 0 | 3                    | 0    | 0     | 0 | 0                    | 0    | 1     | 0 | 11    | 151           |
| 4:45 PM                         | 0                       | 2    | 0     | 0 | 1                       | 0    | 3     | 0 | 2                    | 0    | 1     | 0 | 0                    | 0    | 1     | 0 | 10    | 147           |
| 4:50 PM                         | 0                       | 3    | 1     | 0 | 0                       | 5    | 2     | 0 | 2                    | 0    | 0     | 0 | 0                    | 0    | 2     | 0 | 15    | 140           |
| 4:55 PM                         | 0                       | 2    | 0     | 0 | 1                       | 2    | 3     | 0 | 2                    | 0    | 0     | 0 | 0                    | 0    | 1     | 0 | 11    | 140           |
| 5:00 PM                         | 0                       | 1    | 0     | 0 | 5                       | 3    | 4     | 0 | 2                    | 0    | 0     | 0 | 0                    | 0    | 3     | 0 | 18    | 147           |
| 5:05 PM                         | 0                       | 2    | 0     | 0 | 2                       | 1    | 1     | 0 | 0                    | 0    | 0     | 0 | 0                    | 0    | 5     | 0 | 11    | 140           |
| 5:10 PM                         | 0                       | 2    | 0     | 0 | 2                       | 4    | 2     | 0 | 5                    | 0    | 0     | 0 | 0                    | 0    | 3     | 0 | 18    | 148           |
| 5:15 PM                         | 0                       | 1    | 0     | 0 | 2                       | 0    | 1     | 0 | 2                    | 0    | 0     | 0 | 0                    | 0    | 3     | 0 | 9     | 146           |
| 5:20 PM                         | 0                       | 2    | 0     | 0 | 2                       | 4    | 2     | 0 | 1                    | 0    | 0     | 0 | 0                    | 0    | 1     | 0 | 12    | 149           |
| 5:25 PM                         | 0                       | 1    | 0     | 0 | 0                       | 0    | 2     | 0 | 3                    | 0    | 0     | 0 | 0                    | 0    | 1     | 0 | 7     | 147           |
| 5:30 PM                         | 0                       | 0    | 0     | 0 | 3                       | 1    | 1     | 0 | 2                    | 0    | 0     | 0 | 0                    | 0    | 0     | 0 | 7     | 143           |
| 5:35 PM                         | 0                       | 0    | 0     | 0 | 1                       | 1    | 2     | 0 | 3                    | 0    | 0     | 0 | 0                    | 0    | 0     | 0 | 7     | 136           |
| 5:40 PM                         | 0                       | 0    | 0     | 0 | 1                       | 1    | 1     | 0 | 2                    | 0    | 0     | 0 | 0                    | 0    | 0     | 0 | 5     | 130           |
| 5:45 PM                         | 0                       | 3    | 0     | 0 | 1                       | 4    | 2     | 0 | 3                    | 0    | 0     | 0 | 0                    | 0    | 1     | 0 | 14    | 134           |
| 5:50 PM                         | 0                       | 0    | 0     | 0 | 1                       | 2    | 1     | 0 | 0                    | 0    | 0     | 0 | 0                    | 0    | 0     | 0 | 4     | 123           |
| 5:55 PM                         | 0                       | 3    | 0     | 0 | 3                       | 3    | 3     | 0 | 1                    | 0    | 0     | 0 | 0                    | 0    | 2     | 0 | 15    | 127           |
| 6:00 PM                         | 0                       | 0    | 0     | 0 | 1                       | 2    | 2     | 0 | 2                    | 0    | 0     | 0 | 0                    | 0    | 1     | 0 | 8     | 117           |
| 6:05 PM                         | 0                       | 4    | 0     | 0 | 1                       | 4    | 1     | 0 | 0                    | 0    | 0     | 0 | 0                    | 0    | 0     | 0 | 10    | 116           |
| 6:10 PM                         | 0                       | 1    | 0     | 0 | 0                       | 7    | 2     | 0 | 1                    | 0    | 0     | 0 | 0                    | 0    | 0     | 0 | 11    | 109           |
| 6:15 PM                         | 0                       | 2    | 0     | 0 | 4                       | 3    | 1     | 0 | 1                    | 0    | 0     | 0 | 0                    | 1    | 1     | 0 | 13    | 113           |
| 6:20 PM                         | 0                       | 2    | 0     | 0 | 1                       | 2    | 1     | 0 | 4                    | 0    | 0     | 0 | 0                    | 0    | 2     | 0 | 12    | 113           |
| 6:25 PM                         | 0                       | 2    | 0     | 0 | 0                       | 1    | 4     | 0 | 2                    | 0    | 0     | 0 | 0                    | 0    | 0     | 0 | 9     | 115           |
| 6:30 PM                         | 0                       | 1    | 0     | 0 | 3                       | 2    | 1     | 0 | 3                    | 0    | 1     | 0 | 0                    | 0    | 0     | 0 | 11    | 119           |
| 6:35 PM                         | 0                       | 2    | 0     | 0 | 1                       | 4    | 2     | 1 | 3                    | 0    | 0     | 0 | 0                    | 0    | 0     | 0 | 13    | 125           |
| 6:40 PM                         | 0                       | 4    | 0     | 0 | 3                       | 2    | 1     | 0 | 3                    | 0    | 0     | 0 | 0                    | 0    | 0     | 0 | 13    | 133           |
| 6:45 PM                         | 0                       | 1    | 0     | 0 | 2                       | 1    | 2     | 0 | 0                    | 0    | 0     | 0 | 0                    | 0    | 3     | 0 | 9     | 128           |
| 6:50 PM                         | 0                       | 2    | 0     | 0 | 1                       | 2    | 2     | 0 | 0                    | 0    | 0     | 0 | 0                    | 0    | 1     | 0 | 8     | 132           |
| 6:55 PM                         | 0                       | 1    | 0     | 0 | 1                       | 1    | 1     | 0 | 1                    | 0    | 0     | 0 | 0                    | 0    | 1     | 0 | 6     | 123           |
| 7:00 PM                         | 0                       | 0    | 0     | 0 | 0                       | 3    | 0     | 0 | 0                    | 0    | 0     | 0 | 0                    | 0    | 0     | 0 | 3     | 118           |
| 7:05 PM                         | 0                       | 1    | 0     | 0 | 0                       | 1    | 0     | 0 | 0                    | 0    | 0     | 0 | 0                    | 0    | 1     | 0 | 3     | 111           |
| 7:10 PM                         | 0                       | 4    | 0     | 0 | 2                       | 3    | 0     | 0 | 0                    | 0    | 0     | 0 | 0                    | 0    | 1     | 0 | 10    | 110           |
| 7:15 PM                         | 0                       | 0    | 0     | 0 | 2                       | 1    | 0     | 0 | 2                    | 0    | 0     | 0 | 0                    | 0    | 0     | 0 | 5     | 102           |
| 7:20 PM                         | 0                       | 0    | 0     | 0 | 5                       | 0    | 6     | 0 | 2                    | 0    | 0     | 0 | 1                    | 0    | 1     | 0 | 15    | 105           |
| 7:25 PM                         | 0                       | 1    | 0     | 0 | 0                       | 2    | 4     | 0 | 0                    | 0    | 0     | 0 | 0                    | 0    | 1     | 0 | 8     | 104           |
| 7:30 PM                         | 0                       | 1    | 0     | 0 | 0                       | 0    | 2     | 0 | 3                    | 0    | 0     | 0 | 0                    | 0    | 2     | 0 | 8     | 101           |
| 7:35 PM                         | 0                       | 1    | 0     | 0 | 0                       | 0    | 1     | 0 | 0                    | 0    | 0     | 0 | 0                    | 0    | 1     | 0 | 3     | 91            |
| 7:40 PM                         | 0                       | 0    | 0     | 0 | 0                       | 0    | 1     | 0 | 0                    | 0    | 0     | 0 | 0                    | 0    | 2     | 0 | 3     | 81            |
| 7:45 PM                         | 0                       | 0    | 0     | 0 | 3                       | 1    | 1     | 0 | 1                    | 0    | 0     | 0 | 0                    | 0    | 0     | 0 | 6     | 78            |
| 7:50 PM                         | 0                       | 0    | 1     | 0 | 0                       | 1    | 3     | 0 | 0                    | 0    | 0     | 0 | 0                    | 0    | 0     | 0 | 5     | 75            |
| 7:55 PM                         | 0                       | 2    | 0     | 0 | 2                       | 4    | 3     | 0 | 0                    | 0    | 0     | 0 | 0                    | 0    | 0     | 0 | 11    | 80            |
| 8:00 PM                         | 0                       | 1    | 0     | 0 | 1                       | 2    | 2     | 0 | 0                    | 0    | 0     | 0 | 1                    | 0    | 0     | 0 | 7     | 84            |
| 8:05 PM                         | 0                       | 1    | 0     | 0 | 0                       | 0    | 0     | 0 | 0                    | 0    | 0     | 0 | 0                    | 0    | 1     | 0 | 2     | 83            |
| 8:10 PM                         | 0                       | 0    | 0     | 0 | 5                       | 1    | 1     | 0 | 0                    | 0    | 0     | 0 | 0                    | 0    | 0     | 0 | 7     | 80            |
| 8:15 PM                         | 0                       | 0    | 0     | 0 | 5                       | 5    | 3     | 0 | 1                    | 0    | 0     | 0 | 0                    | 0    | 0     | 0 | 14    | 89            |
| 8:20 PM                         | 0                       | 1    | 0     | 0 | 0                       | 2    | 1     | 0 | 0                    | 0    | 0     | 0 | 0                    | 0    | 2     | 0 | 6     | 80            |
| 8:25 PM                         | 0                       | 1    | 0     | 0 | 1                       | 0    | 1     | 0 | 0                    | 0    | 0     | 0 | 0                    | 0    | 0     | 0 | 3     | 75            |
| 8:30 PM                         | 0                       | 4    | 0     | 0 | 1                       | 1    | 1     | 0 | 0                    | 0    | 0     | 0 | 0                    | 0    | 0     | 0 | 7     | 74            |
| 8:35 PM                         | 0                       | 1    | 0     | 0 | 0                       | 6    | 0     | 0 | 2                    | 0    | 0     | 0 | 0                    | 0    | 1     | 0 | 10    | 81            |
| 8:40 PM                         | 0                       | 1    | 0     | 0 | 0                       | 3    | 2     | 0 | 2                    | 0    | 0     | 0 | 0                    | 0    | 0     | 0 | 8     | 86            |
| 8:45 PM                         | 0                       | 0    | 0     | 0 | 0                       | 2    | 2     | 0 | 2                    | 0    | 0     | 0 | 0                    | 0    | 1     | 0 | 7     | 87            |
| 8:50 PM                         | 0                       | 0    | 0     | 0 | 0                       | 1    | 5     | 0 | 0                    | 0    | 0     | 0 | 0                    | 0    | 1     | 0 | 7     | 89            |
| 8:55 PM                         | 0                       | 1    | 0     | 0 | 1                       | 2    | 2     | 0 | 1                    | 0    | 0     | 0 | 0                    | 0    | 0     | 0 | 7     | 85            |
| 9:00 PM                         | 0                       | 0    | 0     | 0 | 1                       | 0    | 1     | 0 | 0                    | 0    | 0     | 0 | 0                    | 0    | 1     | 0 | 3     | 81            |
| 9:05 PM                         | 0                       | 0    | 0     | 0 | 0                       | 1    | 2     | 0 | 0                    | 0    | 0     | 0 | 0                    | 0    | 1     | 0 | 4     | 83            |
| 9:10 PM                         | 0                       | 0    | 0     | 0 | 0                       | 1    | 1     | 0 | 1                    | 0    | 0     | 0 | 0                    | 0    | 0     | 0 | 3     | 79            |
| 9:15 PM                         | 0                       | 1    | 0     | 0 | 0                       | 0    | 4     | 0 | 0                    | 0    | 0     | 0 | 0                    | 0    | 0     | 0 | 5     | 70            |
| 9:20 PM                         | 0                       | 0    | 0     | 0 | 0                       | 0    | 0     | 0 | 1                    | 0    | 0     | 0 | 0                    | 0    | 0     | 0 | 1     | 65            |
| 9:25 PM                         | 0                       | 0    | 0     | 0 | 1                       | 1    | 1     | 0 | 0                    | 0    | 0     | 0 | 0                    | 0    | 0     | 0 | 3     | 65            |
| 9:30 PM                         | 0                       | 0    | 0     | 0 | 0                       | 0    | 2     | 0 | 0                    | 0    | 0     | 0 | 0                    | 0    | 0     | 0 | 2     | 60            |
| 9:35 PM                         | 0                       | 0    | 0     | 0 | 0                       | 2    | 2     | 0 | 1                    | 0    | 0     | 0 | 0                    | 0    | 0     | 0 | 5     | 55            |
| 9:40 PM                         | 0                       | 0    | 0     | 0 | 1                       | 0    | 1     | 0 | 0                    | 0    | 0     | 0 | 0                    | 0    | 0     | 0 | 2     | 49            |
| 9:45 PM                         | 0                       | 2    | 0     | 0 | 0                       | 1    | 3     | 0 | 2                    | 0    | 0     | 0 | 0                    | 0    | 0     | 0 | 8     | 50            |
| 9:50 PM                         | 0                       | 0    | 0     | 0 | 0                       | 1    | 0     | 0 | 0                    | 0    | 0     | 0 | 0                    | 0    | 0     | 0 | 1     | 44            |
| 9:55 PM                         | 0                       | 0    | 0     | 0 | 1                       | 0    | 0     | 0 | 1                    | 0    | 0     | 0 | 0                    | 0    | 1     | 0 | 3     | 40            |
| Peak 15-Min Flowrates           | Northbound              |      |       |   | Southbound              |      |       |   | Eastbound            |      |       |   | Westbound            |      |       |   | Total |               |
|                                 | Left                    | Thru | Right | U | Left                    | Thru | Right | U | Left                 | Thru | Right | U | Left                 | Thru | Right | U |       |               |
| All Vehicles                    | 0                       | 24   | 4     | 0 | 28                      | 44   | 56    | 0 | 32                   | 0    | 0     | 0 | 8                    | 0    | 12    | 0 | 208   |               |
| Heavy Trucks                    | 0                       | 0    | 0     | 0 | 0                       | 0    | 4     | 0 | 4                    | 0    | 0     | 0 | 0                    | 0    | 0     | 0 | 8     |               |
| Buses                           |                         | 0    |       |   |                         | 0    |       |   |                      | 0    |       |   |                      | 0    |       |   | 0     |               |
| Pedestrians                     | 4                       | 0    | 0     |   | 0                       | 0    | 0     |   | 0                    | 0    | 0     |   | 0                    | 0    | 0     |   | 4     |               |
| Bicycles                        |                         |      |       |   |                         |      |       |   |                      |      |       |   |                      |      |       |   |       |               |
| Scoters                         |                         |      |       |   |                         |      |       |   |                      |      |       |   |                      |      |       |   |       |               |

*Comments:*  
 Report generated on 4/25/2025 4:03 PM SOURCE: Quality Counts, LLC (<http://www.qualitycounts.net>) 1-877-580-2212

# Attachment B – Collision Records

All-Way Stop Control Intersections: Collision Records

| case_id  | accident_year | collision_date | collision_time | primary_rd                  | secondary_rd    | distance | collision_severity | party_count | type_of_collision | party 1             | party 2               | INT | correctable? |
|----------|---------------|----------------|----------------|-----------------------------|-----------------|----------|--------------------|-------------|-------------------|---------------------|-----------------------|-----|--------------|
| 90546727 | 2017          | 20170911       | 800            | GERTRUDE DR. (2600 BLOCK)   | KENSINGTON RD   | 48       | 0                  | 2           | Sideswipe         | Proceeding Straight | Other Unsafe Turning  | 13  | No           |
| 90406796 | 2017          | 20170222       | 1315           | GERTRUDE DRIVE (2600 BLOCK) | KENSINGTON ROAD | 79       | 0                  | 2           | Sideswipe         | Stopped             | Passing Other Vehicle | 13  | No           |
| 91707812 | 2022          | 20220211       | 1425           | KENSINGTON RD (12500 BLOCK) | GERTRUDE DR     | 220      | 0                  | 2           | Broadside         | Making Left Turn    | Proceeding Straight   | 13  | No           |

Source: SWITRS (2017-2023)

Side-Street Stop Control Intersections: Collision Records

| case_id  | accident_year | collision_date | collision_time | primary_rd                   | secondary_rd       | distance | collision_severity | party_count | type_of_collision  | party 1              | party 2             | INT | correctable? |
|----------|---------------|----------------|----------------|------------------------------|--------------------|----------|--------------------|-------------|--------------------|----------------------|---------------------|-----|--------------|
| 90894815 | 2018          | 20181227       | 2141           | QUAIL RUN LN 22000 BLOCK     | DONNIS RD          | 200      | 0                  | 2           | Rear End           | Other Unsafe Turning | Parked              | 1   | No           |
| 91568480 | 2021          | 20210907       | 930            | DONNIS RD.                   | QUAIL RUN RD.      | 0        | 0                  | 2           | Broadside          | Proceeding Straight  | Proceeding Straight | 1   | Yes          |
| 91728721 | 2022          | 20220318       | 755            | DONNIS RD.                   | DONNIE ANN RD.     | 0        | 0                  | 2           | Broadside          | Proceeding Straight  | Proceeding Straight | 2   | Yes          |
| 90986805 | 2019          | 20190501       | 1600           | KENSINGTON RD., 1100 BLOCK   | CHESNEY DRIVE      | 200      | 0                  | 3           | Sideswipe          | Other Unsafe Turning | Parked              | 3   | No           |
| 91610956 | 2021          | 20211027       | 815            | KENSINGTON RD.               | CHESNEY DR.        | 0        | 4                  | 2           | Broadside          | Proceeding Straight  | Proceeding Straight | 3   | Yes          |
| 91730155 | 2022          | 20220310       | 1910           | CHESNEY DRIVE                | LOCH LOMOND ROAD   | 0        | 4                  | 2           | Broadside          | Making Left Turn     | Parked              | 5   | Yes          |
| 91492845 | 2021          | 20210530       | 1710           | SILVER FOX ROAD              | SAINT ALBANS DRIVE | 0        | 0                  | 2           | Broadside          | Proceeding Straight  | Proceeding Straight | 11  | Yes          |
| 91163301 | 2020          | 20200109       | 745            | YARDLEY ST., 9900 BLOCK      | BALL RD.           | 1        | 3                  | 2           | Sideswipe          | Stopped              | Making Right Turn   | 16  | No           |
| 90748293 | 2018          | 20180523       | 1736           | BIENVILLE AVENUE, 9800 BLOCK | ANTIGUA ST         | 25       | 2                  | 2           | Broadside          | Traveling Wrong Way  | Proceeding Straight | 17  | Yes          |
| 91380204 | 2021          | 20210103       | 1845           | ANTIGUA ST, 10000 BLOCK      | BIENVILLE AVE      | 150      | 0                  | 2           | Rear End           | Parked               | Backing             | 17  | No           |
| 91920025 | 2022          | 20221106       | 1510           | BIENVILLE AVE                | ANTIGUA ST         | 0        | 4                  | 2           | Sideswipe          | Proceeding Straight  | Proceeding Straight | 17  | No           |
| 91291770 | 2020          | 20200718       | 2050           | GRAVIER ST., 10000 BLOCK     | BIENVILLE AVE      | 50       | 0                  | 3           | Sideswipe          | Other Unsafe Turning | Parked              | 18  | No           |
| 92036490 | 2023          | 20230403       | 1230           | GRAVIER ST (10000 BLOCK)     | BIENVILLE AVE      | 200      | 0                  | 2           | Hit Object         | Proceeding Straight  | Stopped             | 18  | No           |
| 91153442 | 2019          | 20191216       | 1520           | GUINIDA LN                   | ANTIGUA ST         | 0        | 0                  | 2           | Broadside          | Making Left Turn     | Proceeding Straight | 20  | Yes          |
| 91814486 | 2022          | 20220705       | 1612           | HARLE AVE (9800 BLOCK)       | CHAMBERLAIN AVE    | 135      | 0                  | 2           | Rear End           | Backing              | Proceeding Straight | 21  | No           |
| 90421686 | 2017          | 20170322       | 2500           | ENDRY STREET (10800 BLOCK)   | BANTA AVENUE       | 125      | 0                  | 2           | Sideswipe          | Other Unsafe Turning | Parked              | 22  | No           |
| 90896479 | 2018          | 20181222       | 2215           | ENDRY ST S/B                 | BANTA AVE          | 240      | 0                  | 3           | Rear End           | Parked               | Proceeding Straight | 22  | No           |
| 91083978 | 2019          | 20190921       | 1400           | ENDRY ST 10800 BLOCK         | BANTA AVE          | 100      | 0                  | 3           | Rear End           | Other                | Parked              | 22  | No           |
| 91479509 | 2021          | 20210514       | 1935           | ENDRY ST N/B (9500 BLOCK)    | BANTA AVE          | 200      | 2                  | 2           | Vehicle/Pedestrian | N/A                  | Proceeding Straight | 22  | Yes          |
| 91729632 | 2022          | 20220314       | 1405           | ENDRY ST., 10000 BLOCK       | BANTA AVE          | 50       | 4                  | 2           | Broadside          | Proceeding Straight  | Other               | 22  | Yes          |
| 91158336 | 2020          | 20200102       | 1200           | MAC ST., 10800 BLOCK         | SYRACUSE AVE.      | 35       | 0                  | 4           | Rear End           | Parked               | Other               | 23  | No           |
| 90911069 | 2019          | 20190118       | 1414           | WARREN AVE.                  | CLARISSA LN.       | 0        | 0                  | 2           | Sideswipe          | Other Unsafe Turning | Proceeding Straight | 31  | No           |
| 92249541 | 2023          | 20231115       | 1800           | COUSTEAU LANE                | LA SALLE LANE      | 0        | 0                  | 2           | Sideswipe          | Proceeding Straight  | Proceeding Straight | 56  | No           |
| 90932833 | 2019          | 20190216       | 1640           | SMOKE TREE                   | SCARLET MAPLE      | 20       | 0                  | 1           | Hit Object         | Proceeding Straight  |                     | 60  | No           |

Source: SWITRS (2017-2023)