

SUBORDINATE CONTRACT NO. MA-060-26010796 with WCC Technologies Group is hereby issued per the terms and conditions of Master Agreement MA-017-21010863-C for Structured Cabling and Installation Services.

This Subordinate Contract MA-060-26010796 is made and entered into upon execution of all necessary signatures between WCC Technologies Group, having its principal place of business at 5535 Daniels St., Chino, CA 91710 (hereinafter referred to as "Contractor"), and the County of Orange, a political subdivision of the State of California (hereinafter referred to as "County"), acting through the Orange County Sheriff-Coroner Department, with a place of business at 320 N Flower St 2nd Floor, Santa Ana, CA 92703-5000 (hereinafter referred to as "Sheriff-Coroner"), which are sometimes individually referred to as "Party" or collectively referred to as "Parties".

ATTACHMENTS

This Contract is comprised of this document and the following Attachment, which is incorporated by reference into this Subordinate Contract:

Attachment A – Master Agreement MA-017-21010863-C

RECITALS

WHEREAS, the County of Orange, acting through the County Executive Office, OCIT (hereinafter referred to as "OCIT") executed a Master Agreement MA-017-21010863-C on May 28, 2021 for Structured Cabling and Installation Services, now in effect from June 1, 2021 through and including February 29, 2028; and

WHEREAS, COUNTY, acting through the Sheriff-Coroner, desires to enter into a Subordinate Contract for Structured Cabling and Installation Services pursuant to the terms, conditions and pricing of the Master Agreement, which is attached hereto and incorporated herein by reference as Attachment A;

NOW, THEREFORE, the parties mutually agree:

1. **Scope of Contract:** This Subordinate Contract specifies the terms and conditions by which the County, acting through the Sheriff-Coroner, will procure Structured Cabling and Installation Services from the Contractor (hereinafter referred to as "Services") as more fully detailed in Attachment A, Master Agreement MA-017-21010863-C.
2. **Term of Subordinate Contract:** This Subordinate Contract shall commence upon execution of all necessary signatures by the Parties and continue through and including February 28, 2027, unless otherwise terminated by the County pursuant to the termination provision of the Master Agreement or renewed by a duly executed written amendment between the Parties according to the Master Agreement.
3. **Renewal:** This Contract may be renewed by mutual written agreement of both Parties for one (1) additional one (1) year term. The County does not have to give reason if it elects not to renew. Renewal periods may be subject to approval by the County of Orange Board of Supervisors.
4. **Compensation & Payment:** Contractor agrees to provide the Services in accordance with the terms and condition of the Master Agreement, including its attachments, and at the fixed rates as set forth in Attachment B – Cost/Compensation of the Master Agreement. The total cost of this Subordinate Contract shall not exceed \$1,600,000. The County shall have no obligation to pay any sum in excess of this amount unless authorized by written amendment signed by both Parties.
5. **Invoicing:** Invoicing shall be done in accordance with the terms and conditions of Attachment B – Cost/Compensation of the Master Agreement. Contractor shall reference Subordinate Contract MA-060-

26010796 on invoices. Invoices are to be submitted to the Sheriff-Coroner division requesting the Services:

County of Orange
Sheriff-Coroner Department/Technology Division
1382 Bell Avenue
Tustin, CA 92780
Email: technologyinvoices@ocsheriff.gov

6. Notices: Any and all notices, requests demands and other communications contemplated, called for, permitted, or required to be given hereunder shall be in writing with a copy provided to the assigned Deputy Purchasing Agent (DPA), except through the course of the Parties' project managers' routine exchange of information and cooperation during the terms of the work and services. Any written communications shall be deemed to have been duly given upon actual in-person delivery, if delivery is by direct hand, or upon delivery on the actual day of receipt or no greater than four (4) calendar days after being mailed by US certified or registered mail, return receipt requested, postage prepaid, whichever occurs first. The date of mailing shall count as the first day. All communications shall be addressed to the appropriate party at the address stated herein or such other address as the parties hereto may designate by written notice from time to time in the manner aforesaid.

Contractor:

WCC Technologies Group
5535 Daniels St.
Chino, CA 91710
Attn: John A. Haygood
Phone: 909-364-9906
Email: johnny.haygood@wcctechgroup.com

County:

County of Orange
Sheriff-Coroner Department/Technology Division
1382 Bell Avenue
Tustin, CA 92780
Attn: Madison Meil
Phone: 714-912-3136
Email: mmeil@ocsheriff.gov

Assigned DPA:

County of Orange
Sheriff-Coroner Department/Procurement Division
320 N Flower St 2nd Floor
Santa Ana, CA 92703
Attn: Olivia Prudencio
Phone: 714-834-6687
Email: oprudencio@ocsheriff.gov

IN WITNESS WHERE OF, the Parties have executed this Subordinate Contract number MA-060-26010796.

***Contractor:** WCC Technologies Group

Signed by: John Haygood Title: President
 By: _____ Date: 2/10/2026 | 16:44:06 PST
 Print Name: John Haygood Date: _____

***Contractor:** WCC Technologies Group

Signed by: Matthew Haygood Title: Secretary
 By: _____ Date: 2/10/2026 | 16:44:15 PST
 Print Name: Matthew Haygood Date: _____

**If the contracting party is a corporation, (2) two signatures are required: (1) signature by the Chairman of the Board, the President or any Vice President; and one (1) signature by the Secretary, any Assistant Secretary, the Chief Financial Officer or any Assistant Treasurer.*

The signature of one person alone is sufficient to bind a corporation, as long as he or she holds corporate offices in each of the two categories described above. For County purposes, proof of such dual office holding will be satisfied by having the individual sign the instrument twice, each time indicating his or her office that qualifies under the above-described provision.

In the alternative, a single corporate signature is acceptable when accompanied by a corporate resolution demonstrating the legal authority of the signature to bind the company.

County Of Orange

A political subdivision of the State of California



Sheriff-Coroner Department

By: _____ Title: _____
 Print Name: _____ Date: _____

Approved as to Form

Office of the County Counsel
 Orange County, California
 By: Christopher Anderson
 Deputy



ATTACHMENT A

Master Agreement MA-017-21010863-C



AMENDMENT NO. 4
TO CONTRACT MA-017-21010863-C
FOR
STRUCTURED CABLING AND INSTALLATION SERVICES
BETWEEN
COUNTY OF ORANGE
AND
WCC TECHNOLOGIES GROUP

This Amendment No. 4 to Contract MA-017-21010863-C (hereinafter “Amendment No. 4”) is made and entered into as of the date fully executed by and between the **County of Orange** (hereinafter “County”), a political subdivision of the State of California, and WCC Technologies Group (hereinafter “Contractor”), with a place of business at 5535 Daniels St. Chino CA, 91710 with County and Contractor sometimes individually referred to as “Party or collectively as “Parties”.

RECITALS

WHEREAS, the Parties executed aggregate Contract MA-017-21010863-C (hereinafter “Contract”) for Structured Cabling and Installation Services, effective **June 1, 2021, through and including February 29, 2024**, in an amount not to exceed \$1,250,000 annually; and

WHEREAS, the Parties executed Amendment No. 1 to include an hourly rate for Structured Cabling Engineering and Design Services; and

WHEREAS, the Parties executed Amendment No. 2 to 1) amend provision number two (2) “Term of Contract”, 2) amend provision number three (3) “Renewal”, 3) add provision number nineteen (19) “Safety Data Sheets”, 4) add provision number twenty (20) “Contractor Safety”, and 5) replace Attachment B “Cost/Compensation” in its entirety; and

WHEREAS, on May 22, 2025, Contractor notified County of the company name change from West Coast Cable, Inc. to WCC Technologies Group for rebranding purposes only; and

WHEREAS, the Parties executed Amendment No. 3 to Contract to reflect the Contractor’s new legal business name; and

WHEREAS, the Parties desire to amend the Contract to 1) amend provision number two (2) “Term of Contract”, 2) replace Attachment B “Cost/Compensation”, and 3) amend provision number thirty-three (33) of Part II – General Conditions, and Contractor has agreed to continue to provide Structured Cabling and Installation Services in accordance with the terms herein.

NOW THEREFORE, the Parties mutually agree as follows:

1. Provision number two (2) “Term of Contract” shall be amended to read:

“TERM OF CONTRACT: The term of this Contract shall be effective upon execution of all necessary signatures and continue for seven (7) years from **June 1, 2021, thru and including February 29, 2028**, unless otherwise terminated as provided herein.”

2. Attachment B, Cost/Compensation, shall be deleted in its entirety and replaced with revised Attachment B, attached hereto and incorporated herein by reference.
3. Under Part II – General Conditions, Section 33 “Written Notice”, the following County contact shall be added as follows:
“Agency Name: Orange County Information Technology
Procurement Contract Specialist
Attn: Annie Pham, DPA
Phone: (714)567-7409
Email: Annie.Pham@ocit.oc.gov”
4. All other terms and conditions of Aggregate Contract MA-017-21010863-C, except as amended in this Amendment No. 4 herein, shall remain unchanged and in full force and effect.

END OF RECITALS

SIGNATURE PAGE

In Witness Whereof, the Parties hereto have executed this Amendment No. 4 on the date set forth opposite their signature(s).

Contractor shall provide two signatures as follows:

- 1) The **first signature** must be either the Chairman of the Board, President, or any Vice President.
- 2) The **second signature** must be that of the Secretary, an Assistant Secretary, the Chief Financial Officer, or any Assistant Treasurer.

In the alternative, a single corporate signature is acceptable when accompanied by a corporate resolution or by-laws demonstrating the legal authority of the signature to bind the company.

West Coast Cable, Inc.:

| | | |
|-----------------------------|---------------------------------------|-----------|
| FIRST SIGNATURE | John Haygood | President |
| | Print Name | Title |
| | DocuSigned by: <i>John Haygood</i> | 12/3/2025 |
| | Signature C240428... | Date |
| SECOND SIGNATURE | John Haygood | Secretary |
| | Print Name | Title |
| | DocuSigned by: <i>John Haygood</i> | 12/3/2025 |
| | Signature C240428... | Date |

County of Orange, a political subdivision of the State of California:

| | |
|-------------------------------------|-------------------------|
| Annie Pham | Deputy Purchasing Agent |
| Print Name | Title |
| DocuSigned by: <i>Annie Pham</i> | 1/15/2026 |
| Signature E84B14EB... | Date |

APPROVED AS TO FORM:

| | |
|---------------------------------------|-----------|
| David Obrand | Deputy |
| Print Name | Title |
| DocuSigned by: <i>David Obrand</i> | 12/3/2025 |
| Signature F40B35FD205F40E... | Date |

Attachment B

Cost/Compensation

I. Contractor Pricing

Contractor hourly pricing shall be based upon general prevailing rates of per diem wages and the general prevailing rates for holiday and overtime wages in this locality for each craft, classification, or type of worker needed to execute this Contract.

Contractor shall provide all necessary information requested on a Project-by-Project basis. All cables and termination products provided by the Contractor in service of this Contract shall meet or exceed all applicable ANSI/BICSI NI-2019 and ANSI/TIA 568.1.D standards for performance within their respective product types and be “Name Brand” products. Due to the continuing reports in the Cable Industry of non-compliant and counterfeit cables on the market, no ‘Off-Shore’ cables will be accepted.

- A. The hourly rates shall cover all costs for the work, including direct and indirect labor charges (in accordance with the established general prevailing wage rate requirements), truck, all necessary equipment, tools, overhead, travel, depreciation, other expenses, and all profit.
- B. Labor hours shall be charged based on actual time spent on each job, not on a portal- to- portal basis, and shall be computed to the nearest one-quarter (1/4) hour. Contractor shall maintain payroll records in accordance with Section 1776 of the California Labor Code. Said records shall be made available upon request by the County as provided for in the Labor Code. Contractor shall be subject to the penalties for violations as provided for in the Labor Code.
- C. Contractor shall pay the general prevailing wage rate for all Projects costing more than \$1,000. (Reference Section 1771 of the California Labor Code, General Prevailing Wages). Projects shall not be split to avoid this requirement.
- D. Premium Hour or Special Hour rates shall not be paid on non-emergency response requests unless specifically authorized in writing by the Agency Project Manager or CEO/OCIT at the time the request for service is initiated.
- E. Minimum Call Charge is applicable only when the actual job cost is below the established minimum. It is not a separate or additional charge.
- F. All material items shall be listed on the invoice for each location.
- G. For items not listed in Attachment B – Cost/Compensation, all copies of the actual receipts shall be attached to the invoice.

II. COMPENSATION

This is a Time and Materials based Contract between the County and the Contractor for Structured Cabling and Installation Services, as specified in Attachment A, Scope of Work.

Contractor agrees to accept the compensation as set forth in this Attachment B as full remuneration for (a) performing all services and furnishing all staffing and materials required, (b) any reasonably unforeseen difficulties which may arise or be encountered in the performance of the services until

acceptance, (c) risks connected with the services, and (d) performance by the Contractor of all its duties and obligations required hereunder. The County shall have no obligation to pay any sum in excess of total Contract amount specified herein unless authorized by amendment.

Contractor shall be responsible for all costs related to photocopying, telephone communications, fax communications, travel, parking, and any and all "out of pocket" expenses incurred by the Contractor, during the performance of the services under this Contract unless otherwise specified.

III. PRICING-SERVICES

Table I

| SERVICE | Unit | YEAR 1 | YEAR 2 | YEAR 3 | YEAR 4 | YEAR 5 | YEAR 6 | YEAR 7 |
|--|--------|----------|----------|----------|----------|----------|----------|----------|
| Initial Inspection: Develop Scope of Work | Each | \$0.00 | \$0.00 | \$0.00 | \$0.00 | \$0.00 | \$0.00 | \$0.00 |
| Regular Hours: (Monday thru Friday, 7:00 a.m. - 5:00 p.m.) | Hour | \$80.00 | \$80.00 | \$80.00 | \$88.00 | \$88.00 | \$96.00 | \$96.00 |
| Premium Hours: (Monday thru Friday, 5:01 p.m. - 6:59 a.m.; Saturday 7:00 a.m. - 5:00 p.m.) | Hour | \$111.00 | \$111.00 | \$111.00 | \$111.00 | \$111.00 | \$111.00 | \$111.00 |
| Special Hours: (Saturday 5:01 p.m. - 11:59 p.m.) (Sunday and Holidays) | Hour | \$141.00 | \$141.00 | \$141.00 | \$141.00 | \$141.00 | \$141.00 | \$141.00 |
| Minimum Call Out Charge for Repairs (if applicable) | Call | \$150.00 | \$150.00 | \$150.00 | \$150.00 | \$150.00 | \$150.00 | \$150.00 |
| Engineering and Design Services | Hourly | N/A | N/A | \$175.00 | \$175.00 | \$175.00 | \$175.00 | \$175.00 |

Continued on Next Page

Table II

| MATERIALS | For the Life of the Contract |
|---|------------------------------|
| Mark-Up for Materials | 15% |
| Contractor will provide receipts indicating Contractor cost and corresponding mark-up (See Attachment B Section IV below) | |

Table III

| CREDITS | For the Life of the Contract |
|----------------------------------|---|
| Background Checks | Contractor will credit the County the cost of Background Checks on the appropriate invoice. |
| Service Now Training & Licensing | Contractor will credit the County the cost of Service Now Training & Licensing on the appropriate invoice. See Attachment A, Scope of Services, Section III.A.1 for more information |

IV. TOTAL AGGREGATE CONTRACT AMOUNT NOT TO EXCEED:

\$8,750,000 for the 7-year term.

V. PAYMENT TERMS

Contractor shall reference the Contract number on the invoice. Payment shall be net 45 days in Arrears after receipt of an invoice in a format reasonably acceptable to the County and verified and approved by the agency/department and subject to routine processing requirements. The responsibility for providing an acceptable invoice rests with the Contractor.

Billing shall cover services and/or goods not previously invoiced. The Contractor shall reimburse the County for any monies paid to the Contractor for goods or services not provided or when goods or services do not meet the Contract requirements.

Payments made by the County shall not preclude the right of the County from thereafter disputing any items or services involved or billed under this Contract and shall not be construed as acceptance of any part of the goods or services.

In no event shall County pay Contractor interest or other late charges on any charges or other amounts due under this Contract. County will have the right to set off against amounts owed by County under the Contract any amount the Contractor is obligated to pay or credit County under this Contract.

Receipts of actual cost will need to be provided for other products not listed in Attachment B- Cost/Compensation.

VI. PAYMENT/INVOICING INSTRUCTIONS

A. Within five (5) calendar days after the last day of each calendar month, Contractor shall use its best efforts to invoice County for all charges for services provided in the immediately preceding calendar month. Contractor shall not invoice County, and County shall not be obligated to pay, any charges or other invoiced amounts (including pass through expenses and any charges relating to Contractor’s subcontractors) that are not properly invoiced within sixty (60) calendar days after the end of the month in which such charges were incurred, unless a request for an extension is approved in writing by the County within the sixty (60) calendar days window.

Contractor shall provide an invoice on Contractor’s letterhead for services rendered. Each invoice shall have a number and shall include the following information:

1. Contractor’s name and address
2. Contractor’s remittance address (if different from 1 above)
3. Name of County Agency/Department
4. County Contract number
5. Cost;
 - a. For items not listed in Attachment B – Cost/Compensation such as Materials, copies of all receipts of the actual purchase invoices shall be attached to the invoice;
6. Credits:
 - a. Credit to County for Background Checks performed by County for Contractor staff
 - b. Credit of 2% to County for invoices paid within 15 days
 - c. Credit to County for Service Now Training & Licensing
7. Contractor’s Federal I.D. number; and
8. Total.

B. Contractor shall attach to each invoice submitted:

The Service Request, which shall include:

- a. Date and time services were provided;
- b. Number of labor hours used;
- c. Materials used;
- d. Service Request number;
- e. Name of Contractor performing the services; and
- f. Additional comments.

C. The responsibility for providing an acceptable invoice to the County for payment rests with the Contractor. Incomplete or incorrect invoices are not acceptable and shall be returned to the Contractor for correction. The CEO/OCIT Project Manager, Agency Project Manager or designee, is responsible for approval of invoices and subsequent submittal of invoices to the Auditor-Controller for processing of payment.

Invoices and support documentation are to be forwarded to:

| |
|--|
| County of Orange – CEO/OCIT Attn: Accounts Payable 721 S. Parker St., 2nd Floor Orange, CA 92868 |
|--|

AND

| |
|--|
| ocitaccountspayable@ocit.oc.gov |
|--|



**AMENDMENT NO. 3
TO CONTRACT MA-017-21010863-C
FOR
STRUCTURED CABLING AND INSTALLATION SERVICES
BETWEEN
COUNTY OF ORANGE
AND
WCC TECHNOLOGIES GROUP**

This Amendment No. 3 to Contract MA-017-21010863-C (hereinafter “Amendment No. 3”) is made and entered into as of the date fully executed by and between the **County of Orange** (hereinafter “County”), a political subdivision of the State of California, and WCC Technologies Group (hereinafter “Contractor”), with a place of business at 5535 Daniels St. Chino CA, 91710 with County and Contractor sometimes individually referred to as “Party or collectively as “Parties”.

RECITALS

WHEREAS, the Parties executed aggregate Contract MA-017-21010863-C (hereinafter “Contract”) for Structured Cabling and Installation Services, effective **June 1, 2021, through and including February 29, 2024**, in an amount not to exceed \$1,250,000 annually; and

WHEREAS, the Parties executed Amendment No. 1 to include an hourly rate for Structured Cabling Engineering and Design Services; and

WHEREAS, the Parties executed Amendment No. 2 to 1) amend provision number two (2) “Term of Contract”, 2) amend provision number three (3) “Renewal”, 3) add provision number nineteen (19) “Safety Data Sheets” and provision number twenty (20) “Contractor Safety”, and 5) replace Attachment B “Cost/Compensation” in its entirety; and

WHEREAS, on May 22, 2025, Contractor notified County of the company business name change from West Coast Cable, Inc. to WCC Technologies Group; and

WHEREAS, Contractor represents and warrants that this name change is strictly a change of name and does not involve a change of ownership or transfer of assignment of the Contract; and

WHEREAS, Contractor represents and warrants that all rights, duties, and obligations of the parties under the Contract are unaffected by this name change; and

WHEREAS, the Parties desire to amend the Contract to reflect the Contractor's new legal business name.

NOW, THEREFORE, the Parties mutually agree as follows:

1. The above recitals are hereby incorporated into this Amendment No. 3 as fully stated herein.
2. All references to West Coast Cable, Inc. in the Contract (and all related documents) are hereby amended and replaced with WCC Technologies Group.
3. Contractor agrees to continue to perform all of its duties, responsibilities, and obligations under the Contract under the new business name. Except as amended in this Amendment No. 3, all other terms and conditions of the Contract shall remain in full force and effect.

SIGNATURE PAGE

In Witness Whereof, the Parties hereto have executed this Amendment No. 3 on the date set forth opposite their signature(s).

Contractor shall provide two signatures as follows:

- 1) The **first signature** must be either the Chairman of the Board, President, or any Vice President.
- 2) The **second signature** must be that of the Secretary, an Assistant Secretary, the Chief Financial Officer, or any Assistant Treasurer.

In the alternative, a single corporate signature is acceptable when accompanied by a corporate resolution or by-laws demonstrating the legal authority of the signature to bind the company.

WCC Technologies Group:

| | | |
|-----------------------------|--|------------|
| FIRST SIGNATURE | John Haygood | President |
| | Print Name | Title |
| | DocuSigned by: <i>John Haygood</i> Signature 70938D44C240428... | 11/20/2025 |
| | | Date |
| SECOND SIGNATURE | John Haygood | Secretary |
| | Print Name | Title |
| | DocuSigned by: <i>John Haygood</i> Signature 70938D44C240428... | 11/20/2025 |
| | | Date |

County of Orange, a political subdivision of the State of California:

| | |
|--|-------------------------|
| Annie Pham | Deputy Purchasing Agent |
| Print Name | Title |
| DocuSigned by: <i>Annie Pham</i> Signature 057268FE84B14EB... | 11/24/2025 |
| | Date |



AMENDMENT NO. 2
TO CONTRACT MA-017-21010863-C
FOR
STRUCTURED CABLING AND INSTALLATION SERVICES
BETWEEN
COUNTY OF ORANGE
AND
WEST COAST CABLE, INC.

This Amendment No. 2 to Contract MA-017-21010863-C (hereinafter “Amendment No. 2”) is made and entered into as of the date fully executed by and between the **County of Orange** (hereinafter “County”), a political subdivision of the State of California, and **West Coast Cable, Inc.** (hereinafter “Contractor”), with a place of business at 1828 Railroad St. Corona CA, 92880 with County and Contractor sometimes individually referred to as “Party or collectively as “Parties”.

RECITALS

WHEREAS, the Parties executed aggregate Contract MA-017-21010863-C (hereinafter “Contract”) for Structured Cabling and Installation Services, effective **June 1, 2021 through and including February 29, 2024** in an amount not to exceed \$1,250,000 annually; and

WHEREAS, the Parties executed Amendment No. 1 to include an hourly rate for Structured Cabling Engineering and Design Services; and

WHEREAS, the Parties desire to amend the Contract to amend provision number two (2) “Term of Contract”, amend provision number three (3) “Renewal”, add provision number nineteen (19) “Safety Data Sheets”, add provision number twenty (20) “Contractor Safety”, and replace Attachment B “Cost/Compensation” in its entirety, and Contractor has agreed to continue to provide Structured Cabling and Installation Services in accordance with the terms herein.

NOW THEREFORE, the Parties mutually agree as follows:

1. Provision number two (2) “Term of Contract” shall be amended to read:
“TERM OF CONTRACT: The initial term of this Contract shall be effective upon execution of all necessary signatures and continue for five (5) years from **June 1, 2021, thru and including February 28, 2026**, unless otherwise terminated as provided herein.”
2. Provision number three (3) “Renewal” shall be amended to read:
“RENEWAL: This Contract may be renewed upon expiration for one additional two-year (2) term, upon agreement of both parties. The County is not obligated to give reason if it elects not to renew. Renewal amendments may require approval of the County Board of Supervisors.”
3. Provisions number nineteen (19) and twenty (20) shall be added as follows:
“19. SAFETY DATA SHEETS: Contractor is required to provide a Safety Data Sheet (SDS) compliant with California Code of Regulations, Title 8, Section 5194, for each hazardous substance that is provided, used or created as part of the goods or services provided by Contractor to County. The SDS for each substance must be sent to either the County Project Manager, as specified in the “Notices” provision of this Contract, or to the place of shipment or provision of goods/services.”

“20. CONTRACTOR SAFETY: Contractor shall comply with County’s Safety and Loss Prevention Policy and Procedure #306 (“Contractor Safety Responsibilities”) and submit a copy of its Injury and Illness Prevention Program (IIPP) and Contractor Safety-Activity Checklist to the designated County Procurement staff as part of the solicitation and/or contract process. Contractor will notify County Project Manager of any revisions to the SafetyActivity Checklist and will provide a new Safety-Activity Checklist upon County request. The IIPP shall comply with California Code of Regulations, Title 8, Section 1509 or 3203 (whichever applies). Contractor shall submit other safety programs that pertain to the type of job that will be performed on site. County reserves the right to conduct inspections and audits as necessary for the purpose of evaluating any aspect of safety performance under this Contract.”

4. Attachment B, Cost Compensation, shall be deleted in its entirety and replaced with revised Attachment B, attached hereto and incorporated herein by reference. See separate Attachment entitled “Attachment B, Cost/Compensation, As amended in Amendment No. 2 to Contract MA-017-21010863-C”
5. All other terms and conditions of Aggregate Contract MA-017-21010863-C, except as amended in Amendment No. 1 and herein, shall remain unchanged and in full force and effect.

END OF RECITALS

SIGNATURE PAGE

In Witness Whereof, the Parties hereto have executed this Amendment on the date set forth opposite their signature(s).

Contractor shall provide two signatures as follows:

- 1) The **first signature** must be either the Chairman of the Board, President, or any Vice President.
- 2) The **second signature** must be that of the Secretary, an Assistant Secretary, the Chief Financial Officer, or any Assistant Treasurer.

In the alternative, a single corporate signature is acceptable when accompanied by a corporate resolution or by-laws demonstrating the legal authority of the signature to bind the company.

West Coast Cable, Inc.:

| | | |
|-----------------------------|--------------|-----------|
| FIRST SIGNATURE | John Haygood | President |
| | Print Name | Title |
| | Signature | Date |
| SECOND SIGNATURE | John Haygood | Secretary |
| | Print Name | Title |
| | Signature | Date |

County of Orange, a political subdivision of the State of California:

| | |
|----------------|-------------------------|
| Timothy Shears | Deputy Purchasing Agent |
| Print Name | Title |
| Signature | Date |

APPROVED AS TO FORM:

| | |
|--------------|--------|
| David Obrand | Deputy |
| Print Name | Title |
| Signature | Date |

Attachment B

Cost/Compensation

As amended in Amendment No. 2 to Contract MA-017-21010863-C

I. Contractor Pricing

Contractor hourly pricing shall be based upon general prevailing rates of per diem wages and the general prevailing rates for holiday and overtime wages in this locality for each craft, classification, or type of worker needed to execute this Contract.

Contractor shall provide all necessary information requested on a Project-by-Project basis. All cables and termination products provided by the Contractor in service of this Contract shall meet or exceed all applicable ANSI/BICSI NI-2019 and ANSI/TIA 568.1.D standards for performance within their respective product types and be “Name Brand” products. Due to the continuing reports in the Cable Industry of non-compliant and counterfeit cables on the market, no ‘Off-Shore’ cables will be accepted.

- A. The hourly rates shall cover all costs for the work, including direct and indirect labor charges (in accordance with the established general prevailing wage rate requirements), truck, all necessary equipment, tools, overhead, travel, depreciation, other expenses, and all profit.
- B. Labor hours shall be charged based on actual time spent on each job, not on a portal- to- portal basis, and shall be computed to the nearest one-quarter (1/4) hour. Contractor shall maintain payroll records in accordance with Section 1776 of the California Labor Code. Said records shall be made available upon request by the County as provided for in the Labor Code. Contractor shall be subject to the penalties for violations as provided for in the Labor Code.
- C. Contractor shall pay the general prevailing wage rate for all Projects costing more than \$1,000. (Reference Section 1771 of the California Labor Code, General Prevailing Wages). Projects shall not be split to avoid this requirement.
- D. Premium Hour or Special Hour rates shall not be paid on non-emergency response requests unless specifically authorized in writing by the Agency Project Manager or CEO/OCIT at the time the request for service is initiated.
- E. Minimum Call Charge is applicable only when the actual job cost is below the established minimum. It is not a separate or additional charge.
- F. All material items shall be listed on the invoice for each location.
- G. For items not listed in Attachment B – Cost Compensation, all copies of the actual receipts shall be attached to the invoice.

II. COMPENSATION

This is a Time and Materials based Contract between the County and the Contractor for Structured Cabling and Installation Services, as specified in Attachment A, Scope of Work.

The Contractor agrees to accept the compensation as set forth in this Attachment B as full remuneration for (a) performing all services and furnishing all staffing and materials required, (b) any reasonably unforeseen difficulties which may arise or be encountered in the performance of the services until

acceptance, (c) risks connected with the services, and (d) performance by the Contractor of all its duties and obligations required hereunder. The County shall have no obligation to pay any sum in excess of total Contract amount specified herein unless authorized by amendment.

The Contractor shall be responsible for all costs related to photocopying, telephone communications, fax communications, travel, parking, and any and all "out of pocket" expenses incurred by the Contractor, during the performance of the services under this Contract unless otherwise specified.

III. PRICING-SERVICES

Table I

| SERVICE | Unit | YEAR 1 | YEAR 2 | YEAR 3 | YEAR 4 | YEAR 5 |
|--|--------|----------|----------|----------|----------|----------|
| Initial Inspection: Develop Scope of Work | Each | \$0.00 | \$0.00 | \$0.00 | \$0.00 | \$0.00 |
| Regular Hours: (Monday thru Friday, 7:00 a.m. - 5:00 p.m.) | Hour | \$80.00 | \$80.00 | \$80.00 | \$88.00 | \$88.00 |
| Premium Hours: (Monday thru Friday, 5:01 p.m. - 6:59 a.m.; Saturday 7:00 a.m. - 5:00 p.m.) | Hour | \$111.00 | \$111.00 | \$111.00 | \$111.00 | \$111.00 |
| Special Hours: (Saturday 5:01 p.m. - 11:59 p.m.) (Sunday and Holidays) | Hour | \$141.00 | \$141.00 | \$141.00 | \$141.00 | \$141.00 |
| Minimum Call Out Charge for Repairs (if applicable) | Call | \$150.00 | \$150.00 | \$150.00 | \$150.00 | \$150.00 |
| Engineering and Design Services | Hourly | N/A | N/A | \$175.00 | \$175.00 | \$175.00 |

Table II

| MATERIALS | For the Life of the Contract |
|---|------------------------------|
| Mark-Up for Materials | 15% |
| Contractor will provide receipts indicating Contractor cost and corresponding mark-up (See Attachment B Section IV below) | |

Table III

| CREDITS | For the Life of the Contract |
|----------------------------------|---|
| Background Checks | Contractor will credit the County the cost of Background Checks on the appropriate invoice. |
| Service Now Training & Licensing | Contractor will credit the County the cost of Service Now Training & Licensing on the appropriate invoice. See Attachment A, Scope of Services, Section III.A.1 for more information |

IV. TOTAL AGGREGATE CONTRACT AMOUNT NOT TO EXCEED:

\$6,250,000 for the 5-year term.

V. PAYMENT TERMS

The Contractor shall reference the Contract number on the invoice. Payment shall be net 45 days in Arrears after receipt of an invoice in a format reasonably acceptable to the County and verified and approved by the agency/department and subject to routine processing requirements. The responsibility for providing an acceptable invoice rests with the Contractor.

Billing shall cover services and/or goods not previously invoiced. The Contractor shall reimburse the County for any monies paid to the Contractor for goods or services not provided or when goods or services do not meet the Contract requirements.

Payments made by the County shall not preclude the right of the County from thereafter disputing any items or services involved or billed under this Contract and shall not be construed as acceptance of any part of the goods or services.

In no event shall County pay Contractor interest or other late charges on any charges or other amounts due under this Contract. County will have the right to set off against amounts owed by County under the Contract any amount the Contractor is obligated to pay or credit County under this Contract.

Receipts of actual cost will need to be provided for other products not listed in Attachment B-Cost/Compensation.

VI. PAYMENT/INVOICING INSTRUCTIONS

A. Within five (5) calendar days after the last day of each calendar month, Contractor shall use its best efforts to invoice County for all charges for services provided in the immediately preceding calendar month. Contractor shall not invoice County, and County shall not be obligated to pay, any charges or other invoiced amounts (including pass through expenses and any charges relating to Contractor's subcontractors) that are not properly invoiced within sixty (60) calendar days after the end of the month in which such charges were incurred, unless a request for an extension is approved in writing by the County within the sixty (60) calendar days window.

The Contractor shall provide an invoice on Contractor’s letterhead for services rendered. Each invoice shall have a number and shall include the following information:

1. Contractor’s name and address;
 2. Contractor’s remittance address (if different from 1 above);
 3. Name of County Agency/Department;
 4. County Contract number;
 5. Cost;
 - a. For items not listed in Attachment B – Cost Compensation such as Materials, copies of all receipts of the actual purchase invoices shall be attached to the invoice;
 6. Credits:
 - a. Credit to County for Background Checks performed by County for Contractor staff
 - b. Credit of 2% to County for invoices paid within 15 days
 - c. Credit to County for Service Now Training & Licensing
 7. Contractor’s Federal I.D. number; and
 8. Total.
- B. Contractor shall attach to each invoice submitted:

The Service Request, which shall include:

- a. Date and time services were provided;
 - b. Number of labor hours used;
 - c. Materials used;
 - d. Service Request number;
 - e. Name of Contractor performing the services; and
 - a. Additional comments.F
- C. The responsibility for providing an acceptable invoice to the County for payment rests with the Contractor. Incomplete or incorrect invoices are not acceptable and shall be returned to the Contractor for correction. The CEO/OCIT Project Manager, Agency Project Manager or designee, is responsible for approval of invoices and subsequent submittal of invoices to the Auditor-Controller for processing of payment.

Invoices and support documentation are to be forwarded to:

| |
|--|
| County of Orange – CEO/OCIT Attn: Accounts Payable 1055 N. Main St., 6th Floor Santa Ana, CA 92701 |
|--|

AND

| |
|--|
| ocitaccountspayable@ocit.ocgov.com |
|--|

END OF ATTACHMENT B



**AMENDMENT NO. AMENDMENT NO.1
TO CONTRACT MA-017-21010863-C
FOR
STRUCTURED CABLING AND INSTALLATION SERVICES
BETWEEN
COUNTY OF ORANGE
AND
WEST COAST CABLE, INC.**

This Amendment No. 1 to Contract MA-017-21010863-C (hereinafter “Amendment No. 1”) is made and entered into as of the date fully executed by and between the County of Orange (hereinafter “County”), a political subdivision of the State of California, and **West Coast Cable, Inc.** (hereinafter “Contractor”), with a place of business at **5535 Daniels St., Chino CA, 91710** with County and Contractor sometimes individually referred to as “Party or collectively as “Parties”.

RECITALS

WHEREAS, County and Contractor executed aggregate Contract MA-017-21010863-C (hereinafter “Contract”) for Structured Cabling and Installation Services, effective **June 1, 2021 through and including February 29, 2024** in an amount not to exceed \$1,250,000 annually; and

WHEREAS, County desires to amend the Contract to include an hourly rate for Structured Cabling Engineering and Design Services and Contractor has agreed to continue to provide Structured Cabling and Installation Services in accordance with the terms herein.

NOW THEREFORE, the Parties mutually agree as follows:

- Attachment B, Table I “Pricing – Services” (“Table I”) of the Contract shall be amended to include an hourly rate for Structured Cabling Engineering and Design Services. The amended Table I shall be as follows:

“Table I”

| SERVICE | Unit | YEAR 1 | YEAR 2 | YEAR 3 |
|--|------|----------|----------|----------|
| Initial Inspection: Develop Scope of Work (SOW) | Each | \$0.00 | \$0.00 | \$0.00 |
| Regular Hours: (Monday thru Friday, 7:00 a.m. - 5:00 p.m.) | Hour | \$80.00 | \$80.00 | \$80.00 |
| Premium Hours: (Monday thru Friday, 5:01 p.m. - 6:59 a.m.; Saturday 7:00 a.m. - 5:00 p.m.) | Hour | \$111.00 | \$111.00 | \$111.00 |

| | | |
|--|--------------------|---|
| Orange County Information Technology West Coast Cable, Inc. | Folder No. C029186 | Amendment No. 1 to Contract MA-017-21010863-C Structured Cabling & Installation Services |
|--|--------------------|---|

| | | | | |
|--|--------|----------|----------|----------|
| Special Hours: (Saturday 5:01 p.m. - 11:59 p.m.) (Sunday and Holidays) | Hour | \$141.00 | \$141.00 | \$141.00 |
| Minimum Call Out Charge for Repairs (if applicable) | Call | \$150.00 | \$150.00 | \$150.00 |
| Engineering and Design Services | Hourly | \$175.00 | \$175.00 | \$175.00 |

2. All other terms and conditions of this Contract, except as amended herein, shall remain unchanged and in full force and effect.

END OF RECITALS

| | |
|--------------------------------------|--|
| Orange County Information Technology | Amendment No. 1 to Contract MA-017-21010863-C |
| West Coast Cable, Inc. | Folder No. C029186 Structured Cabling & Installation Services |

SIGNATURE PAGE

In Witness Whereof, the Parties hereto have executed this Amendment on the date set forth opposite their signature(s).

Contractor shall provide two signatures as follows:

- 1) The first signature must be either the Chairman of the Board, President, or any Vice President;
- 2) The second signature must be that of the Secretary, an Assistant Secretary, the Chief Financial Officer, or any Assistant Treasurer.

In the alternative, a single corporate signature is acceptable when accompanied by a corporate resolution or by-laws demonstrating the legal authority of the signature to bind the company.

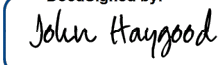
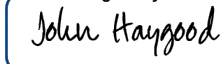
| | |
|---|-------------------------------------|
| <p>John Haygood</p> <hr/> <p>Print Name</p> | <p>President</p> <hr/> <p>Title</p> |
| <p><small>DocuSigned by:</small>  <small>70938D44C240428...</small></p> <hr/> <p>Signature</p> | <p>10/6/2023</p> <hr/> <p>Date</p> |
| <p>John Haygood</p> <hr/> <p>Print Name</p> | <p>Secretary</p> <hr/> <p>Title</p> |
| <p><small>DocuSigned by:</small>  <small>70938D44C240428...</small></p> <hr/> <p>Signature</p> | <p>10/6/2023</p> <hr/> <p>Date</p> |

COUNTY OF ORANGE, a political subdivision of the State of California

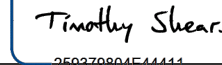
| | |
|--|---|
| <p>Timothy Shears</p> <hr/> <p>Print Name</p> | <p>Deputy Purchasing Agent</p> <hr/> <p>Title</p> |
| <p><small>DocuSigned by:</small>  <small>250370804E444411...</small></p> <hr/> <p>Signature</p> | <p>10/6/2023</p> <hr/> <p>Date</p> |

| | | |
|--------------------------------------|--------------------|---|
| Orange County Information Technology | Folder No. C029186 | Amendment No. 1 to Contract MA-017-21010863-C |
| West Coast Cable, Inc. | | Structured Cabling & Installation Services |



CONTRACT MA-017-21010863-C
FOR
STRUCTURED CABLING AND INSTALLATION SERVICES



THIS CONTRACT, made and entered by and between the County of Orange, a political subdivision of the State of California, hereinafter referred to as "County," and **West Coast Cable, Inc.** hereinafter referred to as "Contractor." County and Contractor mutually agree as follows:

1. The complete Contract Documents comprise the sole agreement between the parties as to the subject matter therein. Any representations or agreements not specifically contained therein are null and void. Any amendments to any Contract Documents must be made in writing, signed by both parties. The Contract Documents are complementary, and what is called for by anyone shall be as binding as if called for by all.
2. **TERM OF CONTRACT:** The initial term of this Contract shall be effective upon execution of all necessary signatures and continue for from **June 1, 2021 thru and including February 29, 2024**, unless otherwise terminated as provided herein.
3. **RENEWAL:** This Contract may be renewed upon expiration of the initial term, for **one (1) additional two-year term**, upon agreement of both parties. The County is not obligated to give reason if it elects not to renew. Renewal amendments may require approval of the County Board of Supervisors.
4. **AGGREGATE CONTRACT:** This is an Aggregate Contract with West Coast Cable, Inc. and Federal Technology Solutions, Inc. with a total Aggregate Contract Amount not to exceed \$1,250,000 annually.
5. **SCOPE OF WORK:** Contractor shall perform everything required to be performed, shall provide and furnish all the labor, supervision, funding, administration, planning, scheduling, materials testing, inspecting, tools, Tasks, equipment and all utility and transportation Tasks in adequate quantity and quality to accomplish completion of the work as specified and all work inferred as necessary within the time period set forth. The work shall conform to the Contract Documents and all codes, regulations, laws, etc. referenced in the Contract Documents or by industry standard.
6. **COUNTY ACCEPTANCE:** All labor, materials, tools, equipment, and Tasks shall be furnished, and work performed and completed under the general direction and subject to the acceptance of County or its authorized representatives.
7. **PAYMENTS:** During the fourth week of the calendar month following the commencement of the work and each successive month thereafter, Contractor shall prepare an accurate progress payment request on a form prescribed by County. The progress payment request shall be in conformance with Article 13 Payments of the General Conditions. Approximately forty-five (45) days after County's written approval of the payment request, the Contractor shall be paid such sum as will bring the payments each month up to ninety-five percent (95%) of the value of the work completed less any money properly withheld in accordance with this Contract, since the commencement of the work, less all previous payments, provided that the Contractor submits his request for payment prior to the last day of each preceding month. The County's Representative will review the payment request as soon as practicable to determine if it is proper. A payment request determined not to be a proper payment request suitable for payment will be returned to the Contractor within seven (7) days with a statement setting forth the reasons why the payment request is not proper. The final payment, if unencumbered, or any part thereof unencumbered, shall be made no later than sixty (60) days after completion of the work including the Contractor's submission and the County's acceptance of all required completion documents. Payments shall be made on the progress payment request signed by the County stating that the work for which the payment is demanded has been performed in accordance with the terms of the Contract, and that the amount stated in the payment request is due under the terms of the Contract. Contractor is entitled to interest pursuant to Public Contract Code Section 20104.50, if County fails to make any progress payment within 30 days after receipt of an undisputed and properly submitted payment request. Failure to make the final payment in accordance with the requirements of Public Contract Code Section 7107, shall entitle Contractor to

additional payments as specified in Public Contract Code Section 7107(f). Partial payments on the Contract price shall not be considered as an acceptance of any part of the work.

8. **LIQUIDATED DAMAGES; EXTENSION OF TIME:** In accordance with Government Code Section 53069.85, Contractor agrees to forfeit and pay to County the sum of Five Hundred Dollars (**\$500**), per day for each calendar day work is delayed beyond the time allowed, and such sum shall be deducted from any payments due to or to become due to Contractor. Contractor will be granted an extension of time and will not be assessed liquidated damages for unforeseeable delays beyond the control of and without the fault or negligence of the Contractor including delays caused by County.
9. **WAIVER OF CLAIMS:** Unless a shorter time is specified elsewhere in this Contract, on or before making his final request for payment under Article 5 above, Contractor shall submit to County, in writing, all claims for compensation under or arising out of this Contract; the acceptance by Contractor of the final payment shall constitute a waiver of all claims against County under or arising out of this Contract except those previously made in writing and identified by Contractor as unsettled at the time of his final request for payment.
10. **WARRANTY WORK:** Failure by the Contractor to take corrective action within twenty four (24) hours after personal or telephonic notice by the County on items affecting essential use of the facility, safety or the preservation of property, and within ten (10) calendar days following written notice on other deficiencies, will result in the County taking whatever corrective action it deems necessary. All costs resulting from such action by the County will be claimed against Contractor or, if necessary, the Contractor's Performance Bond.
11. **WAGE RATES:** Contractor shall post a copy of the wage rates at the job site and shall pay the adopted prevailing wage rates as a minimum. Pursuant to the provisions of Section 1773 of the Labor Code of the State of California, the Board of Supervisors has obtained the general prevailing rate of per diem wages and the general prevailing rate for holiday and overtime work in this locality for each craft, classification, or type of workman needed to execute this Contract from the Director of the Department of Industrial Relations. These rates are on file with the Clerk of the Board of Supervisors. Copies may be obtained at cost at the office of County's Public Works/OC Facilities & Asset Management/A&E Project Management or visit the website of the Department of Industrial Relations, Prevailing Wage Unit at www.dir.ca.gov/DLSR/PWD. The Contractor shall comply with the provisions of Sections 1774, 1775, 1776 and 1813 of the Labor Code.
12. **GOVERNING LAW AND VENUE:** This Contract has been negotiated and executed in the State of California and shall be governed by and construed under the laws of the State of California. In the event of any legal action to enforce or interpret this Contract, the sole and exclusive venue shall be a court of competent jurisdiction located in Orange County, California, and the parties hereto agree to and hereby submit to the jurisdiction of such court, notwithstanding Code of Civil Procedure Section 394.

The parties specifically agree that by soliciting and entering into and performing Tasks under this Contract, the Contractor shall be deemed to constitute doing business within Orange County from the time of solicitation of work, through the period when all work under this Contract is completed, and continuing until the expiration of any applicable limitations period. Furthermore, the parties have specifically agreed, as part of the consideration given and received for entering this Contract, to waive any and all rights to request that an action be transferred for trial to another county under Code of Civil Procedure Section 394.

13. **Omitted.**
14. **APPRENTICESHIP REQUIREMENTS:** The Contractor shall comply with Section 230.1(A), California Code of Regulations as required by the Department of Industrial Relations, Division of Apprenticeship Standards by submitting DAS Form to the Joint Apprenticeship Committee of the craft or trade in the area of the site.
15. **STATE AUDIT AND ACCOUNTING RECORDS:** Pursuant to and in accordance with Section 8546.7 of the California Government Code, if this Contract involves expenditures of public funds aggregating in excess of Ten Thousand Dollars (\$10,000), the Contractor shall be subject to the examination and audit of the Auditor General of the State of California for a period of three years after final payment under the Contract.

CONTRACTOR shall maintain records for all costs connected with the performance of the Contract including but not limited to the costs of administering the Contract, materials, labors, equipment, rentals, permits, insurance, etc. for audit or inspection by County, State, or by any other appropriate governmental agency during the three year period.

16. **EMPLOYEE ELIGIBILITY VERIFICATION:** The Contractor warrants that it fully complies with all Federal and State statutes and regulations regarding the employment of aliens and others and that all its employees performing work under this Contract meet the citizenship or alien status requirement set forth in Federal statutes and regulations. The Contractor shall obtain, from all employees performing work hereunder, all verification and other documentation of employment eligibility status required by Federal or State statutes and regulations including, but not limited to, the Immigration Reform and Control Act of 1986, 8 U.S.C. §1324 et seq., as they currently exist and as they may be hereafter amended. The Contractor shall retain all such documentation for all covered employees for the period prescribed by the law. The Contractor shall indemnify, defend with counsel approved in writing by County, and hold harmless, the County, its agents, officers, and employees from employer sanctions and any other liability which may be assessed against the Contractor or the County or both in connection with any alleged violation of any Federal or State statutes or regulations pertaining to the eligibility for employment of any persons performing work under this Contract.
17. **REGISTRATION OF CONTRACTOR:** All contractors and subcontractors must comply with the requirements of Labor Code Section 1771.1(a), pertaining to registration of contractors pursuant to Section 1725.5. Bids cannot be accepted from unregistered contractors except as provided in Section 1771.1. All Work Orders and Projects under this contract are subject to compliance monitoring and enforcement by the Department of Industrial Relations. After award of the contract, Contractor and each Subcontractor shall furnish electronic payroll records directly to the Labor Commissioner in the manner specified in Labor Code Section 1771.4.
18. **BONDS REQUIREMENTS:**

Within 10 calendar days after award of the Contract, the successful Bidder shall furnish a Faithful Performance Bond and a Labor and Material Payment Bond, each in an amount equal to 100% of the Contract Price, issued by a surety in accordance with the requirements of the General Conditions of the Contract. The bonds shall be in the form of the models included in these Bid Documents and must be approved by COUNTY's Risk Manager and County Counsel. The successful Bidder shall submit the bonds in duplicate, all of which shall bear original signatures. The signature of the surety representative must be notarized.

END OF THIS SECTION

ATTACHMENT A
SCOPE OF SERVICES

I. Overview

The County consists of twenty-four (24) County Agencies/Departments (Agency) that provide a wide range of services, including health care, public safety and elections. The County Executive Office/Orange County Information Technology (CEO/OCIT) supports County-wide information technology initiatives, providing enterprise architecture planning, deployment, and management services to increase efficiency for the County Agency. As part of the information technology initiatives, the County will establish a contract with the selected Contractor(s) to provide structured cabling, installation, and related services.

II. Service Request

Contractor shall be assigned each Project via Service Request by the County which shall referred to as a “Service Request.” A Service Request for each Project shall be developed by Contractor in conjunction with the County Project Manager. The County Project Manager shall manage all the Contractor’s work including monitoring the Service Request schedule, quality of deliverables, review invoice amounts, adherence to set budget, and internal review of submittal packets. Contractor shall follow all the requirements in this Scope of Work.

The Service Request shall include a detailed Scope of Work, describing the tasks to be performed with a specific list of deliverables for each task, schedule of work and cost to complete the work. The Service Request shall include a cover sheet provided by the County Project Management staff with the appropriate signature blocks and contract information. Once both Parties agree, and all parties have signed Service Request, County Management staff shall provide the Contractor with a Notice to Proceed (“NTP”) to begin work.

No individual Project or Service Request under this Contract shall exceed \$60,000. Projects or Service Request shall not be intentionally split or separated into smaller Projects or Service Request for the purpose of evading this provision.

PUBLIC CONTRACT CODE SECTION 20123.5 NOTICE: “In any county, it is unlawful to split or separate into smaller work orders or projects any public work project for the purpose of evading the provisions of this article requiring public work to be done by contract after competitive bidding. Every person who willfully violates the provisions of this section is guilty of a misdemeanor.”

Contracts issued to a single Contractor that exceed \$200,000 in aggregate, per year, shall require approval of the County Board of Supervisors.

III. Scope

A. Procedures for Services

1. Contractor shall utilize Service Now, the County’s service request management system to coordinate and manage Service Request with County Project Manager(s).
 - i. Contractor will be responsible for training cost, approximately \$5,000, to be provided by County Managed Services vendor.
 - ii. Contractor will be responsible for annual licensing fee, approximately \$1,400 per user license, for Contractor personnel who will need to utilize Service Now to manage Service Requests.
2. Contractor shall, within three (3) business days for small Projects (1-25 cable runs), and up to 10 business days for large scale Projects (remodeling existing buildings or new building construction) of receiving a written request for services, provide a written quote

to CEO/OCIT, or the requesting County Agency, for approval of the requested services. Such written quote shall be valid for ninety (90) calendar days.

3. Contractor shall provide consultant services requested by (County) CEO/OCIT. Such services shall be quoted as described in paragraph A.2. above and billed directly to CEO/OCIT as part of the Service Request.
4. Contractor shall discuss and document all work to be completed with the Agency Project Manager and CEO/OCIT prior to beginning performance of the requested services.
5. Contractor shall document in detail all the requirements of each Project if the requirements are not provided by CEO/OCIT or the requesting Agency. All documentation shall be attached to the Service Request.
6. Contractor shall ensure all cables installed are terminated per manufacturer's specification for warranty purposes and clearly marked as recommended by the current ANSI/TIA-606-C the Administration Standard for Commercial Telecommunications Infrastructure.
7. Contractor shall ensure all data cables are tested per the manufacturers' specifications and meet or exceed the current revision(s) of all ANSI/TIA 568.1-D Standards for Structured Cabling Systems in Commercial Buildings. Contractor shall provide a copy of the testing procedure(s) it uses, including all test results, to the Agency Project Manager and CEO/OCIT. The supporting documentation shall be attached to the completed Service Request. Prior to completion of the Service Request, the Contractor shall resolve, at Contractor's expense, any deficiencies identified during testing.
8. Contractor shall, if requested by the County, provide a daily progress report to the Agency Project Manager for Projects lasting longer than one (1) day. Such report shall be provided to CEO/OCIT or the Agency Project Manager by 10:00 AM on the business day following the day being reported on.
9. Contractor shall perform all necessary work in a professional manner and notify CEO/OCIT or the Agency Project Manager within one (1) business day of completion of work.
10. Contractor shall ensure all trash and discarded materials and/or products used for the Project are cleaned up and appropriately disposed of after each working shift.
11. Contractor shall describe/explain all work completed and have CEO/OCIT or the Agency Project Manager examine the finished product for acceptance. Contractor must have CEO/OCIT or the Agency Project Manager sign off on the Service Request and leave a copy of the signed document with the Agency Project Manager or CEO/OCIT.
12. Contractor shall submit an invoice to CEO/OCIT Budget and Finance indicating the labor and material used for the work. The invoice shall include the Service Request.
13. Contractor and Contractor's personnel/employees providing services under this Contract shall be required to pass background checks. Background checks shall be completed to the satisfaction level of each County Agency requiring the background check.

B. Warranty and Repairs

1. Contractor shall provide a minimum of one (1) year warranty on all new parts and equipment.
2. Contractor shall include, when applicable, all manufacturers' warranties and/or extended warranties in excess of the one (1) year warranty expressly required in paragraph B.1. above.
3. Remanufactured parts or supplies will not be accepted by the County.
4. Contractor shall respond to all warranty repair requests during normal business hours of 8:00 AM – 5:00 PM Pacific Time (PT) Monday through Friday, within eight (8) hours of the logged call to Contractor.
5. Should County request emergency services not covered under warranty to be provided during evening hours, weekends or holidays, Contractor shall provide the requested services and shall invoice County pursuant to Attachment B – Cost/Compensation.
6. Contractor shall warranty all labor and materials used to complete its Projects for a period of one (1) year plus any manufactures' extended warranty after completion of and acceptance of the Contractor's work by the County.
7. Contractor shall assure that low voltage contractor must have a certified Siemen Installer (CI) on every low voltage cabling installation.

C. Equipment, Materials and Tools

1. Contractor shall furnish all tools and materials, including, but not limited to: copper/fiber optic cable, usual and specialty equipment, qualified staff, and all out-of-pocket expenses required to provide the requested Structured Cabling and Installation Services necessary to complete the specific Project. All materials shall be new, first quality and specifically suited for the intended use.
2. Contractor shall ensure that qualified and appropriately trained staff, such as apprentice/journeyman level electricians or equivalent, certified structured cable installers, splicers, or other necessary and qualified staff required to complete the Project, are available to work on all aspects of the County's Projects.
3. Contractor shall provide travel arrangements and/or furnish vehicles required to transport Contractor personnel/employees' materials and equipment to the various job sites throughout the County.
4. Contractor shall furnish, install and maintain all warning devices, i.e., barricades, cones, traffic display boards, etc., required to adequately protect the public, County staff and others during the performance of the requested work.
5. Contractor shall ensure that all tools and materials remain within the span of control of Contractor at all times. All lost or misplaced tools or materials shall be reported immediately to the (a) security staff or Agency Project Manager in secured detention facilities or (b) the escort or Agency Project Manager in Sheriff or Probation facilities.
6. Contractor and/or Contractor personnel/employees shall ensure that all materials from removal operations or new construction (especially those materials that could be used to inflict injury such as nails, wire, wood, etc.) are continuously cleaned up as work progresses. This is particularly stressed in all secure detention facilities.

D. Contractor Responsibilities

1. Contractor shall meet with CEO/OCIT and the Agency Project Manager, or other designated Agency representative, to evaluate a specific Project and recommend a

potential solution or solutions and provide a quote with the estimated labor hours and materials required.

2. Contractor shall proceed with work only after receiving written authorization by CEO/OCIT and the Agency Project Manager.
3. Contractor shall complete all work in accordance with its estimate. If Contractor determines the work may exceed the original estimate by more than ten (10) percent, Contractor shall contact CEO/OCIT and the Agency Project Manager for additional written authorization prior to proceeding with the work.
4. Contractor shall complete all work within regular working hours. No overtime work shall be performed without prior written authorization of CEO/OCIT and the Agency Project Manager. Any overtime work performed by Contractor without prior written authorization shall only be paid at the regular hourly rates pursuant to Attachment B – Cost/Compensation.
5. Contractor shall perform all work in accordance with ANSI/TIA/EIA Commercial Building Structured Cabling Standards, Grounding and Bonding Standards, Administration Standards and all generally accepted industry practices for safe and efficient operation and performance, as further identified in Attachment C – Acceptance and Testing Procedures.
6. Contractor shall identify and advise CEO/OCIT and the Agency Project Manager of any additional repair or maintenance work that may be required to complete the Project.
7. Contractor shall be responsible for all parking costs and expenses incurred while performing work under this Contract if free parking is not available.
8. Contractor shall follow County’s Change Management Process. (See Exhibit IV)
9. For any labor or material not specified in Attachment “B” Cost/Compensation the Contractor must provide a quote for labor and parts. The quote must include the actual cost plus agreed upon margin.

E. Licenses, Permits, and Certifications

1. Contractor shall be fully responsible for possessing, maintaining and keeping current, and for providing to County (upon the County’s request) all valid licenses issued by the California State Contractors License Board.
2. **Certifications:** Contractor shall be C-7 and C-10 certified. Contractor shall be certified in Siemen and Panduit products. Contractor shall have a minimum of 5 years’ experience installing, testing, maintaining and updating Structured Cabling Systems in Commercial and Government buildings ranging in size from less than 5 to over 1,000 employees. Low voltage contractor is required to have a certified Siemen Installer (CI) on every low voltage cabling installation.
3. Contractor shall provide all certifications held by its organization as it pertains to the equipment and services being provided; including any mandatory certifications required by manufacturers’ warrantied installations.
4. **Asbestos Identification Training and Notification:** Contractor shall provide asbestos awareness training and certification to all Contractor staff from an accredited asbestos training school in accordance with [OSHA 29 CFR § 1926.1101](#) prior to working in any County owned, controlled or occupied building. Thereafter, Contractor employees shall receive asbestos awareness training and certification annually. Upon completion of training, Contractor employees shall be issued a training completion certificate and/or wallet card. Any Contractor staff that does not have a current certification and/or wallet

card may not perform any work in a County owned, controlled or occupied building. County may, at any time, request proof of certification of Contractor's employees. Upon discovery of asbestos or asbestos containing materials, Contractor staff shall immediately stop work, notify the County Project Manager and shall not resume work until directed to do so by the County's Project Manager. Contractor shall not be responsible for abatement of asbestos-containing material(s).

F. Response Times

1. Contractor shall provide Non-Emergency Services and have staff on-site within eight (8) business hours of receiving the initial County service call.
2. Contractor shall provide Emergency Services and have staff on-site within four (4) hours of receiving the initial County service call.
3. Contractor shall provide and maintain a live or automated answering system capable of contacting and dispatching Contractor's service personnel twenty-four (24) hours per day, seven (7) days per week.

G. Personnel Requirements

1. Contractor or Contractor's personnel/employees shall not smoke or use profanity or other inappropriate language while at any County facility/site. Smoking is allowed in designated areas only.
2. Contractor or Contractor's personnel/employees shall arrive at the County facility/site no more than fifteen (15) minutes prior to the schedule start time.
3. Contractor or Contractor's personnel/employees shall immediately contact the designated Agency Project Manager if a delay or cancellation is necessary. Repeated delays or cancellations shall be grounds for remedial action, which may include Contract termination.
4. Contractor or Contractor's personnel/employees shall report to the Agency Project Manager or onsite contact upon arrival at the job site. The County Project Manager shall ensure the work area is clear and ready for work to begin and follow any special security requirements issued by the Agency Project Manager and/or the onsite contact.
5. Contractor or Contractor's personnel/employees shall report to the Agency Project Manager or onsite contact when leaving the facility either temporarily or at the end of the workday.
6. Contractor or Contractor's personnel/employees shall immediately report all accidents, spills, damage, unusual conditions, and/or unusual activities to the Agency Project Manager or onsite contact.
7. Contractor or Contractor's personnel/employees shall securely close and check all gates and doors to ensure they are tightly closed and locked before leaving the work area.
8. Contractor or Contractor's personnel/employees shall restrict all activities to the immediate work site and adjacent assigned areas.

H. Detention Center Additional Requirements

The primary purpose of County detention facilities is the safe and secure operation of those facilities. Contractor shall inform all its personnel/employees working in secure detention County facilities that:

1. Contractor or Contractor's personnel/employees shall immediately comply with all directions and orders issued by Sheriff or Probation Department personnel. Any changes regarding the quality or quantity of work shall be controlled and/or approved or denied

- by the Agency Project Manager or CEO/OCIT. Contractor or Contractor's personnel/employees may be delayed or denied access to the facility.
2. Contractor or Contractor's personnel/employees may be ordered to leave a facility prior to the completion of their work or the end of the workday.
 3. Contractor or Contractor's personnel/employees may be detained within a facility until an incident is resolved by Sheriff or Probation personnel.
 4. Contractor or Contractor's personnel/employees must allow for minor delays in its cost estimates. Movement within secure facilities may be delayed due to lack of escort personnel. Contractor shall take this into consideration when planning their work in these facilities.
 5. Contractor or Contractor's personnel/employees shall maintain a log of such delays during the course of the Project. Contractor may submit a request for equitable adjustments for excessive delays caused by the County for consideration; requests are subject to review and approval of the Agency Project Manager or CEO/OCIT, in their sole and absolute discretion.
 6. Contractor or Contractors personnel/employees shall have no contact, either verbal or physical, with internees in secured detention facilities.
 7. Contractor or Contractor's personnel/employees shall not disclose the identity of any internee to anyone outside the facility.
 8. Contractor or Contractor's personnel/employees who enter a secure facility without passing the security screening, who have falsified the security screening information or who have outstanding wants and/or warrants may be detained by the Sheriff in accordance with Federal, State and Local laws.
 9. Contractor or Contractor's personnel/employees shall, in secured detention facilities, remain with the assigned escort at all times, unless otherwise directed by the onsite Security Manager.
 10. Personnel Requirements in **Youth Detention Facilities:**
 - a. Contractor or Contractor's personnel/employees shall make arrangements for use of facility keys (if authorized for this work) prior to the start of work.
 - b. Contractor or Contractor's personnel/employees shall check out keys when entering the site and return keys when leaving the site. Keys shall not be removed from the site for any reason. Keys shall be securely fastened to Contractor staff at all times. Lost keys shall be reported immediately, replaced, and building locks rekeyed at Contractor's expense.
 - c. Contractor or Contractor's personnel/employees shall check all gates and doors when entering or exiting an area to ensure the gates and doors are tightly closed, locked and secured.
 - d. Contractor shall only bring into the Youth Detention Facilities the tools needed to perform work. Contractor must account for all tools when leaving the Youth Detention Facility. If Contractor finds any of its tools are missing, Contractor must report this information to Facilities Personnel, Facility Agency, Project Manager and or CEO/OCIT immediately.
 - e. Contractor shall report any suspicious activity to authorities immediately.

Failure to comply with the above requirements is a criminal act and can result in prosecution.

I. County Responsibilities

1. The County shall ensure that the Service Request will indicate the Agency Project Manager, the installation address and the billing address, which may or may not be the same.
2. The County is responsible for processing and tracking Service Requests.
3. The County will notify the Contractor of a pending Service Request.
4. The County will provide electronic delivery of the Service Request for any pending cabling requests.
5. The County shall select the Contractor for a Project based on availability of the Contractor, Project time frames, cost, available contract funding, and the discretion of CEO/OCIT.
6. The County shall provide Contractor or Contractor's staff reasonable access to facilities, working areas, offices, etc.

IV. County of Orange Cabling Standards General Requirements

Installation practices are to meet all applicable building and NFPA 70, National Electrical Code (NEC). Cabling installations shall be performed according to ANSI/BICSI N1-2019 and ANSI/TIA 568.1D. All copper cable shall meet or exceed the minimum transmission specifications for balanced twisted pair cable as defined in ANSI/TIA 568.2-D. Fiber optic cable shall meet or exceed the minimum transmission specifications and testing requirements as defined in ANSI/TIA-455-78B, ANSI/TIA-526-7-A, and ANSI/TIA-526-14-C. Pathways shall meet the requirements of ANSI/TIA 569-D. All Backbone Cables, Patch Panels, Terminal Outlets, Punch Blocks and Fiber Termination enclosures shall be labeled (P-touch or equivalent) on both ends per ANSI/TIA 606-C.

The County of Orange is currently replacing all of the existing network and voice equipment with a converged VoIP/Data Network. Existing legacy systems will retain the cabling infrastructure with separate voice and data cables to the work areas. Facilities that have been 'transformed' to the new converged network environment will have a new single cable configuration for both voice and data services. Please see Exhibits referenced below for the County's cable standards for both environments.

Exhibit I – Structured Cabling and Installation Services. General Requirements for Legacy Facilities

Exhibit II – Structured Cabling and Installation Services. Standards for Converged VoIP and Data Facilities

Exhibit III – Preferred Product List

Exhibit IV- County of Orange Change Management Process

Under no circumstances shall the requirements of this document supersede any Federal, State or Local building or safety codes. The AHJ (Authority Having Jurisdiction) shall be the final arbiter of any and all code interpretations and implementations.

ATTACHMENT B**COST/COMPENSATION**

I. CONTRACTOR PRICING

Contractor hourly pricing shall be based upon general prevailing rates of per diem wages and the general prevailing rates for holiday and overtime wages in this locality for each craft, classification, or type of worker needed to execute this Contract.

Contractor shall provide all necessary information requested on a Project-by-Project basis. All cables and termination products provided by the Contractor in service of this Contract shall meet or exceed all applicable ANSI/BICSI NI-2019 and ANSI/TIA 568.1.D standards for performance within their respective product types and be “Name Brand” products. Due to the continuing reports in the Cable Industry of non-compliant and counterfeit cables on the market, no ‘Off-Shore’ cables will be accepted.

- A. The hourly rates shall cover all costs for the work, including direct and indirect labor charges (in accordance with the established general prevailing wage rate requirements), truck, all necessary equipment, tools, overhead, travel, depreciation, other expenses and all profit.
- B. Labor hours shall be charged on the basis of actual time spent on each job, not on a portal- to-portal basis, and shall be computed to the nearest one-quarter (1/4) hour. Contractor shall maintain payroll records in accordance with Section 1776 of the California Labor Code. Said records shall be made available upon request by the County as provided for in the Labor Code. Contractor shall be subject to the penalties for violations as provided for in the Labor Code.
- C. Contractor shall pay the general prevailing wage rate for all Projects costing more than \$1,000. (Reference Section 1771 of the California Labor Code, General Prevailing Wages). Projects shall not be split to avoid this requirement.
- D. Premium Hour or Special Hour rates shall not be paid on non-emergency response requests unless specifically authorized in writing by the Agency Project Manager or CEO/OCIT at the time the request for service is initiated.
- E. Minimum Call Charge is applicable only when the actual job cost is below the established minimum. It is not a separate or additional charge.
- F. All material items shall be listed on the invoice for each location.
- G. For items not listed in Attachment B – Cost Compensation, all copies of the actual receipts shall be attached to the invoice.

II. COMPENSATION

This is a Time and Materials based Contract between the County and the Contractor for Structured Cabling and Installation Services, as specified in Attachment A, Scope of Work.

The Contractor agrees to accept the compensation as set forth in this Attachment B as full remuneration for (a) performing all services and furnishing all staffing and materials required, (b) any reasonably unforeseen difficulties which may arise or be encountered in the performance of the services until acceptance, (c) risks connected with the services, and (d) performance by the Contractor of all its duties and obligations required hereunder. The County shall have no obligation to pay any sum in excess of total Contract amount specified herein unless authorized by amendment.

The Contractor shall be responsible for all costs related to photocopying, telephone communications, fax communications, travel, parking, and any and all "out of pocket" expenses incurred by the Contractor, during the performance of the services under this Contract unless otherwise specified.

III. PRICING - SERVICES

Table I

| SERVICE | Unit | YEAR 1 | YEAR 2 | YEAR 3 |
|--|-------------|---------------|---------------|---------------|
| Initial Inspection: Develop Scope of Work (SOW) | Each | \$0.00 | \$0.00 | \$0.00 |
| Regular Hours: (Monday thru Friday, 7:00 a.m. - 5:00 p.m.) | Hour | \$80.00 | \$80.00 | \$80.00 |
| Premium Hours: (Monday thru Friday, 5:01 p.m. - 6:59 a.m.; Saturday 7:00 a.m. - 5:00 p.m.) | Hour | \$111.00 | \$111.00 | \$111.00 |
| Special Hours: (Saturday 5:01 p.m. - 11:59 p.m.) (Sunday and Holidays) | Hour | \$141.00 | \$141.00 | \$141.00 |
| Minimum Call Out Charge for Repairs (if applicable) | Call | \$150.00 | \$150.00 | \$150.00 |

Table II

| MATERIALS | For the Life of the Contract |
|--|-------------------------------------|
| Mark-Up for Materials | 15% |
| Contractor will provide receipts indicating Contractor cost and corresponding mark-up (See Attachment B Section IV below) | |

Table III

| CREDITS | For the Life of the Contract |
|----------------------------------|---|
| Background Checks | Contractor will credit the County the cost of Background Checks on the appropriate invoice. |
| Service Now Training & Licensing | Contractor will credit the County the cost of Service Now Training & Licensing on the appropriate invoice. See Attachment A, Scope of Services, Section III.A.1 for more information |

IV. Total Aggregate Contract Amount Not to Exceed: \$3,750,000 for the initial term.

V. PAYMENT TERMS

The Contractor shall reference the Contract number on the invoice. Payment shall be net 45 days in Arrears after receipt of an invoice in a format reasonably acceptable to the County and verified and approved by the agency/department and subject to routine processing requirements. The responsibility for providing an acceptable invoice rests with the Contractor.

Billing shall cover services and/or goods not previously invoiced. The Contractor shall reimburse the County for any monies paid to the Contractor for goods or services not provided or when goods or services do not meet the Contract requirements.

Payments made by the County shall not preclude the right of the County from thereafter disputing any items or services involved or billed under this Contract and shall not be construed as acceptance of any part of the goods or services.

In no event shall County pay Contractor interest or other late charges on any charges or other amounts due under this Contract. County will have the right to set off against amounts owed by County under the Contract any amount the Contractor is obligated to pay or credit County under this Contract.

Receipts of actual cost will need to be provided for other products not listed in Attachment B-Cost/Compensation.

VI. PAYMENT/INVOICING INSTRUCTIONS

- A. Within five (5) calendar days after the last day of each calendar month, Contractor shall use its best efforts to invoice County for all charges for services provided in the immediately preceding calendar month. Contractor shall not invoice County, and County shall not be obligated to pay, any charges or other invoiced amounts (including pass through expenses and any charges relating to Contractor's subcontractors) that are not properly invoiced within sixty (60) calendar days after the end of the month in which such charges were incurred, unless a request for an extension is approved in writing by the County within the sixty (60) calendar days window.

The Contractor shall provide an invoice on Contractor's letterhead for services rendered. Each invoice shall have a number and shall include the following information:

1. Contractor's name and address;
2. Contractor's remittance address (if different from 1 above);
3. Name of County Agency/Department;
4. County Contract number;
5. Cost;
 - a. For items not listed in Attachment B – Cost Compensation such as Materials, copies of all receipts of the actual purchase invoices shall be attached to the invoice;
6. Credits:
 - a. Credit to County for Background Checks performed by County for Contractor staff and/or,
 - b. Credit to County for Service Now Training & Licensing
7. Contractor's Federal I.D. number; and
8. Total.

- B. Contractor shall attach to each invoice submitted:

The Service Request, which shall include:

- a. Date and time services were provided;
- b. Number of labor hours used;
- c. Materials used;
- d. Service Request number;
- e. Name of Contractor performing the services; and
- f. Additional comments.

- C. The responsibility for providing an acceptable invoice to the County for payment rests with the Contractor. Incomplete or incorrect invoices are not acceptable and shall be returned to the Contractor for correction. The CEO/OCIT Project Manager, Agency Project Manager or designee, is responsible for approval of invoices and subsequent submittal of invoices to the Auditor-Controller for processing of payment.

Invoices and support documentation are to be forwarded to:

County of Orange – CEO/OCIT
Attn: Accounts Payable
1055 N. Main St.,
6th Floor
Santa Ana, CA 92701

AND

ocitaccountspayable@ocit.ocgov.com

END OF ATTACHEMENT B

ATTACHMENT C

ACCEPTANCE AND TESTING PROCEDURES

Contractor shall provide Acceptance and Testing Procedures to be utilized to ensure that the Structured Cabling and Installation Services are operating in compliance with County specifications and requirements, which include, but are not limited to, the following:

1. Contractor shall ensure all cabling equipment meets or exceeds the minimum performance requirements described in the ANSI/BICSI N1-2019 and ANSI/TIA 568 telecommunications standards for Structured Cabling Systems. Contractor also shall ensure any video or CCTV (Closed Circuit TV) installations comply with the applicable standards described in the ANSI/TIA/EIA telecommunications standards. The installation and testing standards must, at a minimum, satisfy the following sections of the ANSI/TIA/EIA telecommunications standards: sections 526, 568, 570 and 862, which cover Optical Fiber, Commercial and Residential balanced twisted pair and low voltage Building Automation System (BAS) cabling performance standards. The installation and testing also shall comply with any specific manufacturer's installation and test procedures necessary to ensure the installed products have the full manufacturer's warranty.
2. Contractor shall ensure all installations comply with the following standards: (1) ANSI/BICSI N1-2019 and ANSI/TIA 568, (2) ANSI/TIA/EIA-569-D Commercial Building Standards for Telecommunications Pathways and Spaces, and (3) ANSI/TIA-758 Customer Owned Outside Plant Telecommunications Cabling Standard. Any installation not meeting these requirements will not be accepted and may require additional work at the Contractor's expense.
3. Contractor shall ensure all panels, terminal outlets, cross connect fields and terminations are labeled in accordance with ANSI/TIA/EIA-606-C Administration Standard for Commercial Telecommunications Infrastructure.
4. Contractor shall ensure grounding procedures follow ANSI/TIA 607-C, Generic Telecommunications Bonding and Grounding (Earthing) for Customer Premises.
5. If Contractor is requested to perform a specialized installation for a specific agency (e.g., a conference room Project or, sound systems, etc.), Contractor shall ensure all performance and test standards are still performed.
6. Contractor shall ensure tests are performed on 100% of all newly installed copper cable runs and fiber strands, as required in the County's Managed Services Contract providing for maintenance of strict service and uptime Service Level Agreements (SLA). As stated in the Structured Cabling System Standards (Exhibits II and III), Fiber Optic Cables require a successful Tier I, "Power Sum Loss" test for acceptance. Any failures in the Tier I test will require a subsequent Tier II, OTDR test to determine the point of failure. Significant failure rates within the Fiber Optic cable (i.e. greater than ten (10) percent failure rate) may require replacement of the entire cable at the Contractor's expense.
7. Contractor shall ensure all test results are submitted to the contracting Agency Project Manager and/or CEO/OCIT Voice Services. The results shall be provided in 'electronic copy' with no special software required to read the results. If necessary, the Contractor may provide an Adobe 'reader' (If the results are in a proprietary format) with the test results to facilitate viewing.
8. Contractor shall ensure all installations comply with any and all applicable National Fire Protection Association (NFPA) codes for fire protection and life safety requirements. However, in the event a requirement in this Contract creates a conflict between the NFPA codes and a Local, State or Federal Code

or the Authority Having Jurisdiction (AHJ), the code section or the AHJ has precedence over the NFPA codes.

Any work performed under this Contract that does not meet the above stated requirements will constitute a failure to comply with the requirements of this Contract and will not be considered for acceptance until any deficiencies have been corrected at the Contractor's expense.

END OF ATTACHMENT C

ATTACHMENT D**STAFFING PLAN**

The Contractor shall provide a description of its staffing plan sufficient to demonstrate a clear understanding and ability to meet the service requirements, goals and objectives of the SOW (Scope of Work).

- The Contractor shall provide a staffing plan that:
 - Includes the Contractor's strategy to utilize staff to meet the requirements set forth in the Contract's SOW (roles and responsibilities).
 - Identifies primary/key personnel to perform Contract duties and provides resumes of the same.
- The Contractor shall describe the organization's structure and chain of command and provide an Organization Chart.

The Contractor's primary staff to perform the requirements set forth in the Contract's Scope of Work (attach organizational chart and resumes as additional pages).

| Name | Classification/Designation | Certification(s) |
|------------------|-----------------------------------|------------------------------------|
| John A. Haygood | Designer | RCDD |
| Robert Korteland | Project Manager | Siemon Certified |
| Armando Arellano | Project Manager | Siemon Certified/Panduit Certified |
| Louie Medina | Lead Technician | Siemon Trained/Fluke |
| Juan Lascano | Lead Technician | Siemon Trained |

*The Contractor shall obtain written approval from the County's Project Manager prior to making any substitutions for individual Project team members. However, the Contractor may not request, and the County will not approve, changes to the number and types of classifications.

END OF ATTACHMENT D

EXHIBIT I

STRUCTURED CABLING AND INSTALLATION SERVICES GENERAL REQUIREMENTS FOR LEGACY FACILITIES

Terminal Outlets (Station Side)

The standard faceplate shall be a single gang (duplex) white or ivory* Siemen or Leviton with two (2) positions for jack inserts, one (1) Voice and one (1) Data**.

All work area jacks are to use Cat 6, 6A or 6AF, as specified***. Voice insert shall be white, and Data shall be blue. Inserts can be either a solid color or use color coded icons indicating voice or data with the aforementioned color codes. If colored icons are to be used, the insert shall be White or Ivory depending on the faceplate color.

Voice Insert: white/white icon; 8 position category 6

Data Insert: blue/blue icon; 8 position category 6***

Voice and Data Cables shall use Cat 6, 23AWG, 4 pair cable unless otherwise specified***.

Voice and Data jacks shall be wired per ANSI/TIA/EIA-568-B T568B pin assignments. Please see Modular ‘Y’ Adaptor” (below) for work areas that require multiple voice devices.

* County Agency Representative shall determine faceplate color. If no color is specified, use white.

** Additional Cables/Inserts may be requested at time of installation (i.e., two voice, two data).

*** UTP is the typical cable used; however, in environments that may have high levels of EMI or RFI, STP cables may be used when requested by an Agency. Some Agencies planning on future bandwidth requirements may call for Cat 6A or Cat 6AF cable. This shall be determined on a site-by-site basis.

Equipment Side –ER/TR

Voice cables shall terminate on Cat 5e 66M1-50 punch blocks (Siemon S66M1-50 or equivalent) on a blue backboard per ANSI/TIA/EIA-606-B standards. Sufficient distribution system(s) must be included to support the horizontal cross-connect wiring.

For existing facilities with Cat 5e data cable installed, new data runs shall use Cat 6, Cat 6A or Cat 6AF cable as specified***. In new or existing facilities, data cables shall terminate on a Siemon or Leviton 24 or 48 port open patch panel with the appropriate 8 position inserts, rack mounted, labeled, tested and documented for specific Category operation. No run shall exceed 90m (295’) allowing for 5m (16’) at each end for patch cords.

A minimum of one (1) horizontal wire management system must be installed for each horizontal patch panel installed. (1-RU for 24 port panel; 2-RU for a 48-port panel) All rack installations require a minimum of one (1) vertical wire management system, two (2) if majority of rack is used for horizontal cabling terminations.

An additional 10’-15’ of horizontal cabling (voice and data) must be left properly supported in the ceiling or within the ER/TR if ladder racks are provisioned for this purpose.

Fiber Installations

Current County Multimode fiber is 62.50/125 and uses ST connectors. We shall continue to use this in all existing facilities for new fiber installations. Existing or new sites may use 50/125 OM3 or OM4 MM fiber. Specific fiber optic cable requirements will be determined on a site-by-site basis by the Agency and CEO/OCIT. Single mode

fiber terminations are to use SC connectors. This shall help to minimize any confusion on the fiber type, SM or MM when installations are being performed in the field. All optic fiber terminations are to use hot melt glue or anaerobic adhesives, no pre-polished mechanical type connectors. All splice connections must be fusion spliced.

All fiber installations must comply with NEC requirements. Transition from OSP fiber to ISP fiber must be within 50' of entry into any building. Contractor may, if practical, use indoor-outdoor fiber to avoid any splicing when making ingress/egress to/from a building.

All fiber installations must meet EIA/TIA 568-B.3 specification on optical fiber cabling and pass Gigabit transmission specifications. This is required for both Single-mode and Multi-mode fiber. All optical fiber components and installation practices shall meet applicable building and safety codes. Fiber Patch Cords shall be a two-fiber strand (duplex) cable of same type as the cables to which they connect.

Connectors shall be protected from physical damage and moisture. Connector designs shall meet the requirements of the corresponding TIA/FOCIS documents. Optical fiber cable connecting hardware should be designed to provide flexibility for mounting on walls, in racks or on other types of distribution frames and standard mounting hardware.

Test results of all optic fiber installations are required. Results must be documented, and a copy provided to the County's representative. See Cable Standards below.

All new fiber runs must be certified using the Tier I fiber tests: Power Sum Loss with length measurement. If the fiber fails the Power Sum Loss test, an OTDR test shall be required to determine the source of the problem. All fiber cables and installed systems must meet or exceed ANSI/TIA/EIA-568-B.1, B.1-3 & B.3 performance specifications. All test results must be provided in soft copy to customer without the need for special software for viewing. If this is not possible, then the Contractor may provide a 'reader' with the test results.

If at any time there is a conflict between this document and local building codes, the local building codes shall take precedent and be adhered to in order to comply with the regulation(s).

Modular 'Y' Adaptors

The County cable standards recommend the use of single cable/single jack configurations for voice applications. If there is a need to have multiple voice devices (i.e. fax line & telephone set), there shall be no 'pair-splitting' behind the terminal outlet (jack). If two devices are required technicians must use the Modular Y adaptor shown below. The Y adaptor shall provide two 2-pair connections from a single 4-pair cable and prevent the need to perform any rewiring in the wall. If more than two additional voice devices are required, the user must submit a TSR for an additional cable and have the terminal outlet reconfigured.

Modular Y Adaptors: Single T568B RJ45 to 2-4wire voice – Siemon PN YA4-U2-U2

Description: Splits a 4-pair T568B jack for Token Ring or voice applications at either jack Product

Type: Splits a 4-pair T568B jack for Token Ring or voice applications at either jack

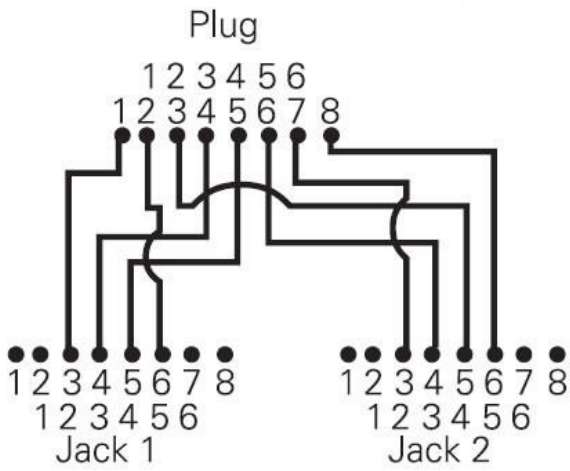
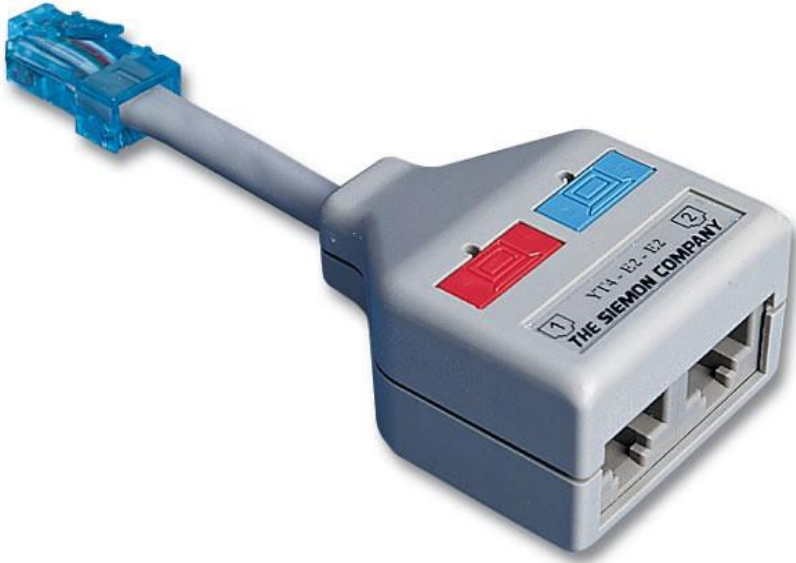

EXHIBIT II

STRUCTURED CABLING AND INSTALLATION SERVICES STANDARDS FOR CONVERGED VOIP AND DATA FACILITIES

The County of Orange Cabling Standards is intended to provide a guideline for the County's Agencies and Contractors providing structured cabling installations. The practices in this document reflect the ANSI/TIA/EIA family of Commercial & Residential Building Cabling Standards. Adherence to these industry standards will ensure the County's Inside and Outside Plant Structured Cabling infrastructure meets or exceeds the minimum performance standards and installation practices as defined in these standards. The ANSI/TIA/EIA standards are referenced throughout this document.

Installation practices are to meet all applicable building and NFPA 70 NEC. All cable work must adhere to the ANIS.BICSI N1-2019, Installation Practices for Telecommunications and ICT Cabling and Related Cabling Infrastructure. Cabling installations are to be performed according to ANSI/TIA 568.0-D, General Telecommunications Cabling for Customer Premises. All copper cable, UTP and STP, and components must meet or exceed the minimum transmission specifications for balanced twisted pair cable as defined in ANSI/TIA-568.2-D, Balanced Twisted-Pair Telecommunications Cabling and Components Standards. Fiber optic cable must meet or exceed the minimum transmission specifications as defined in ANSI/TIA-568.3-D, Optical Fiber Cabling and Components Standard. All communications cable pathways for building interiors and outside plant must meet the requirements of ANSI/TIA/EIA-569-C Commercial Building Standards for Telecommunications Pathways and Spaces. All Backbone and Horizontal cables (copper or fiber) Patch Panels, Terminal Outlets, Consolidation Points and Fiber Termination panels must be labeled (P-touch or equivalent) on both ends per ANSI/TIA-606-B specifications.

TERMINAL OUTLETS (WORK AREA/STATION SIDE)

The standard faceplate will be a single gang (duplex) white or ivory* faceplate with two (2) positions for jack inserts, one (1) active Data cable and one (1) Blank insert**. The active connection shall be in the top, or left, position.

All terminal outlets (jacks) are to use the correct 'Category' keystone inserts to match the horizontal cable being installed. Cat5e, Cat6 or Cat6a inserts as specified***. The Data shall be Blue with a White insert for the spare port. Inserts can be either a solid color or use color coded icons indicating data with the assigned color. If colored icons are to be used, the spare insert shall be White or Ivory to match the faceplate color.

Data Insert: blue/blue icon; 8 position wired T568B Category 6***

Spare Insert: white or ivory to match faceplate*

Horizontal Cables will use Cat6, 23AWG, 4 pair UTP cable unless otherwise specified***.

All terminal outlets shall be wired per ANSI/TIA/EIA-568-C T568B pin assignments.

* County Agency Representative shall determine faceplate color. If no color is specified, use white.

** At Agency's direction, additional Cables/Inserts may be requested at the time of installation.

*** UTP is the typical cable used; however, in environments that may have high levels of EMI or RFI, STP cables may be used when requested by an Agency. Some Agencies planning on future bandwidth requirements may call for Cat 6A or Cat 6AF cable. This shall be determined on a site-by-site basis.

EQUIPMENT SIDE –ER/TR

Where applicable, copper backbone (riser) cables for TDM services (i.e. fax, modem, payphone, Inmate phones,

alarm/paging systems, etc.) will terminate on Cat5e 66M1-50 punch blocks (Siemon S66M1-50 or equivalent) on a blue backboard per ANSI/TIA/EIA-606-B standards. “Telco” patch panels (25pr copper cable to Amphenol connection on patch panels) shall be used to connect the riser cable to the horizontal patch panel rack(s).

Sufficient pathway distribution systems, as defined in ANSI/TIA-569-D, must be included to support the horizontal cross-connect wiring. This shall include, but is not limited to, wire management, ladder rack or cable trays in the Equipment and Terminal rooms. Cable trays, J-hooks or conduits must be used in all plenum or non-plenum areas required to bring horizontal cables to the work areas. Whenever possible, horizontal pathways must be supported independently of ceiling support systems. Cable pathway systems shall not be fastened to any seismic support cables for T-bar ceilings.

For existing facilities with Cat5e data cable installed and available patch panel ports a Cat5e cable can be installed. Otherwise, for new horizontal cable runs, Cat6, Cat6a or Cat6af cable will be used as specified by the Agency IT or OCIT***. In new or existing facilities all horizontal cables will terminate on a Siemon (preferred) or Leviton patch panel. Patch panel capacity, 24 or 48 ports, will be determined by the immediate requirements with consideration for future growth.

Patch panels shall be mounted in standard 2 post open rack, labeled, tested and documented for specific Category operation. No horizontal cable run shall exceed 90m (295’) allowing for 5m (16’) at each end for patch cords. Where practicable, an open 24 or 48 port patch panel with the appropriate 8 position inserts may be used in lieu of a prewired 24 or 48 port panel.

A minimum of one horizontal wire management system must be installed for each horizontal patch panel installed (1-RU for 24 port panel; 2-RU for a 48-port panel). All rack installations require a minimum of one vertical wire management system, two if majority of rack is used for horizontal cabling terminations.

An additional 10’-15’ of horizontal cabling (voice and data) must be left properly supported above the ceiling or within the ER/TR if ladder racks are provisioned for this purpose. This will provide additional length for future room reconfiguration if/when required.

Fiber Installations

Existing County Multimode (MM) fiber can be either 62.50/125 or 50/125 and uses ST connectors. However, newer installations have been migrating to the SC type. Existing or new sites may use 50/125 OM3 or OM4 MM fiber. Specific fiber optic cable requirements will be determined on a site-by-site basis by the Agency and CEO/OCIT. Contractors must confirm the type of fiber and connectors required with the requesting agency’s IT personnel to ensure proper connectivity. Existing Single Mode (SM) fiber terminations are SC connectors. Initially County fiber installations used ST connectors for Multimode and SC connectors for Single mode to differentiate between the fiber types. This is no longer the case as SC & LC connectors have become the preferred connector type regardless of the fiber used. The Contractor must ensure they have the proper type of connector for the installed fiber type and electronics being installed. The current connector types in use at the County are ST, SC and LC, with electronic fiber cards being both GBIC and SFP. All optic fiber terminations are to use hot melt glue, anaerobic adhesives or factory terminated strands, no pre-polished mechanical type connectors. **All splice connections must be fusion spliced to minimize dB loss across the link.**

All fiber installations must meet ANSI/TIA-568.3-D, Optical Fiber Cabling and Components Standard specification on optical fiber cabling and pass Gigabit transmission specifications. This is required for both Single-mode and Multi-mode fiber. All optical fiber components and installation practices shall meet applicable building and safety codes. Fiber Patch Cords shall be a two-fiber strand (duplex) cable of same type as the cables to which they connect.

Connectors shall be protected from physical damage and moisture. Connector designs shall meet the requirements

of the applicable TIA/FOCIS documents. Optical fiber cable connecting hardware should be designed to provide flexibility for mounting on walls, in racks or on other types of distribution frames and standard mounting hardware.

All new fiber runs must be certified using the Tier I fiber tests: Power Sum Loss with length measurement. If the fiber fails the Power Sum Loss test, an OTDR test will be required to determine the source of the problem. All fiber cables and installed systems must meet or exceed ANSI/TIA-568.3-D, Optical Fiber Cabling and Components Standard specification. All test results must be provided in soft copy to customer. If the test results are on proprietary software, the Contractor must provide a 'reader' with the test results or convert the results to a standard format document such as Word, Excel or Adobe PDF.

All cable installations, copper or fiber, must comply with NEC requirements for use in outdoor, indoor plenum and non-plenum applications. Transition from OSP to ISP must be within 50' of visible entry into the occupied space of any building. Contractor may, if practicable, use indoor-outdoor cables to avoid any splicing when making ingress/egress to/from a building.

If any time there is a conflict between this document, local building codes or the NEC, unless the AHJ directs otherwise, Contractor must adhere to the latest revision of the NFPA 70, NEC. The Contractor and the County must keep records of any decisions made by the AHJ that conflict with the NFPA 70, NEC as proof of actions if any future litigation should arise.

Notes:

* County Agency Representative will determine faceplate color. Special order colors may be requested to match office décor. If no color is specified, use white.

** Additional Cables/Inserts may be requested at time of installation when multiple network devices are to be placed in a specific work area.

*** Some Agencies planning on future bandwidth requirements may call for Cat6a or Cat6af cable. This will be determined by the Agency IT or CEO/OCIT on a site-by-site basis.

EXHIBIT III

Below is listing of County's preferred structured cabling products, but is not limited to the following:

| Manufacturer | Part # | Product | Notes |
|---|------------------|---|--|
| Category 6A F/UTP CABLE | | | |
| Siemon | 9C6P4-A5-XX-AR1A | Plenum- CBL,CPR,CAT6A,A5,4-PR,SLD,UTP,CMR,BLU,RL,1000F,23AWG | Cable Colors: 01=Black, 02=White, 3=Red, 4=Gray, 05=Yellow, 06=Blue, 07 = Green, 8=Violet, 9= Orange |
| Siemon | 9C6R4-A5-XX-AR1A | Riser- CBL,CPR,CAT6A,A5,4-PR,SLD,UTP,CMR,BLU,RL,1000F,23AWG | |
| Category 6A GAP Cable | | | |
| Siemon | 9U6P4-A5-XX-R1A | Plenum- 6A Gap Technology (GT) UTP cable features a discontinuous foil construction | Cable Colors: 01=Black, 02=White, 3=Red, 4=Gray, 05=Yellow, 06=Blue, 07 = Green, 8=Violet, 9= Orange |
| Siemon | 9U6R4-A5-XX-R1A | Riser- 6A Gap Technology (GT) UTP cable features a discontinuous foil construction | |
| Category 6A UTP Cable | | | |
| Siemon | 9A6P4-A5-XX-R1A | Plenum- CBL,CPR,CAT6A,A5,4-PR,SLD,F/UTP,CMR,BLK,RL,1000F,23AWG,75C | Cable Colors: 01=Black, 02=White, 3=Red, 4=Gray, 05=Yellow, 06=Blue, 07 = Green, 8=Violet, 9= Orange |
| Siemon | 9A6R4-A5-XX-R1A | Riser- CBL,CPR,CAT6A,A5,4-PR,SLD,F/UTP,CMR,WHT,RL,1000F,23AWG,75C | |
| Category 6A OSP- F/UTP | | | |
| Siemon | 9A6O4-A5-01-R1A | Category 6A outside plant direct burial cable, 4-pair, 23-AWG, F/UTP, black, 305m (1000 ft.) reel | |
| Category 6A OSP- UTP | | | |
| Siemon | 9C6O4-A5-01-R1A | Category 6A Outside Plant Direct Burial Cable, 4-pair, 23-AWG, UTP, Black, 305m (1000 ft.) Reel | |
| Category 6A OSP- Indoor / Outdoor | | | |
| Siemon | 9A6W4-A5-12-R1A | Category 6A Indoor/Outdoor Cable. 4-pair, 23AWG, F/UTP, Teal, 305m (1000 ft.) Reel. | |
| Category 6A UTP Patch Panels- Non-Populated | | | |
| Siemon | Z6A-PF-24 | 24-Port Flat Patch Panel UTP | |
| Siemon | Z6A-PA-24 | 24-Port Angled Patch Panel UTP | |
| Siemon | Z6A-PF-48 | 48-Port Flat Patch Panel UTP | |
| Siemon | Z6A-PA-48 | 48-Port Angled Patch Panel UTP | |
| Category 6A F/UTP Shielded Patch Panels- Non-Populated | | | |
| Siemon | Z6AS-PF-24 | SHIELDED 24-Port Flat Patch Panel | |
| Siemon | Z6AS-PA-24 | SHIELDED Angled 24 PORT Patch Panel | |
| Siemon | Z6AS-PF-48 | SHIELDED 48-Port Flat Patch Panel | |
| Siemon | Z6AS-PA-48 | SHIELDED Angled 48 PORT Patch Panel | |

| Category 6A UTP Patch Panels- Populated | | | |
|--|------------------|---|---|
| Siemon | Z6A-PF-24K | 24-Port Flat Patch Panel UTP | |
| Siemon | Z6A-PA-24K | 24-Port Angled Patch Panel UTP | |
| Siemon | Z6A-PF-48K | 48-Port Flat Patch Panel UTP | |
| Siemon | Z6A-PA-48K | 48-Port Angled Patch Panel UTP | |
| Category 6A F/UTP Shielded Patch Panels- Populated | | | |
| Siemon | Z6AS-PF-24K | SHIELDED 24-Port Flat Patch Panel | |
| Siemon | Z6AS-PA-24K | SHIELDED Angled 24 PORT Patch Panel | |
| Siemon | Z6AS-PF-48K | SHIELDED 48-Port Flat Patch Panel | |
| Siemon | Z6AS-PA-48K | SHIELDED Angled 48 PORT Patch Panel | |
| Category 6A Panel Outlets – F/UTP SHIELDED | | | |
| Siemon | Z6A-SP | Siemon Z-MAX™ 6A Shielded Outlet RJ-45 | |
| Category 6A Panel Outlets – UTP | | | |
| Siemon | Z6AP | Siemon Z-MAX 6A UTP outlet RJ-45 | |
| Category 6A Station Outlets – F/UTP | | | |
| Siemon | Z6A-S(XX) COLORS | Siemon Z-MAX 6A F/UTP outlet RJ-45 | 1=black,2= white,3= red,4= gray,5= yellow,6= blue,7= green,9= orange, 20=ivory,25= bright white,80= light ivory |
| Category 6A Station Outlets – UTP | | | |
| Siemon | Z6A(XX) COLOR | Siemon Z-MAX 6A UTP outlet RJ-45 | 1=black,2= white,3= red,4= gray,5= yellow,6= blue,7= green,9= orange, 20=ivory,25= bright white,80= light ivory |
| Category 6A Field Terminated Modular Plugs- F/UTP | | | |
| Siemon | ZP1-6AS-01(X) | Z-PLUG Category 6A Field-Terminated Plug and Boot with Black Latch Protector Clip | |
| Category 6A Siemon 10G MAX^a Series Faceplates | | | |
| Siemon | MX-FP-S-01 | Single Gang 1-Port | black, white, gray, ivory and light ivory |
| Siemon | 10GMX-FPS02 | Single Gang 2-Port | |
| Siemon | 10GMX-FPS04- | Single Gang 4-Port | |
| Siemon | 10GMX-FPD06 | Double Gang 6-Port | |
| Siemon | 10GMX-FPD08 | Double Gang 8-Port | |
| Category 6A Faceplates – Modular Furniture Adapters | | | |
| Siemon | MX-UMA-01 | Siemon Universal Modular Furniture Adapter | 1=black,2= white,4= gray,5= yellow,6= blue,7= green,9= orange, 20=ivory,25= bright white,80= light ivory |
| Category 6A MX-SMZ^a Series Surface Mount Boxes | | | |
| Siemon | MX-SMZ1 | Surface Mount Boxes 1 | Black = 01,White=02 Ivory = 20, Light Ivory = 80 |
| Siemon | MX-SMZ2 | Surface Mount Boxes 2 | |
| Siemon | : MX-SMZ4 | Surface Mount Boxes 4 | |

| | | | |
|---|------------------|---|--|
| Siemon | MX-SMZ6 | Surface Mount Boxes 6 | |
| Blank Inserts | | | |
| Siemon | MX-BL-02 | Blank Inserts | |
| Category 6A Patch Cords – UTP | | | |
| Siemon | ZM6A-(XX)-(XX) | First (XX) denotes length, second (XX) denotes jacket color | standard lengths of 3, 5, 7, 10, 15, 20, 25, 50, 100 ft., colors , Black, White, Red, Gray, Yellow, Blue, Green and Orange |
| Category 6A Patch Cords –F/UTP (Shielded) | | | |
| Siemon | ZM6A-S(XX)-(XX) | First (XX) denotes length, second (XX) denotes jacket color | standard lengths of 3, 5, 7, 10, 15, 20, 25, 50, 100 ft., colors , Black, White, Red, Gray, Yellow, Blue, Green and Orange |
| Connecting Blocks – 66 / 110 Blocks | | | |
| Siemon | S66M1-50 | 66 Block | |
| Siemon | S110DW1-50-89 | 110 Block | |
| Singlemode Optical Fiber – Indoor/Outdoor | | | |
| Siemon | 9GD8P006D-E201A | 6-Strand | |
| Siemon | 9GD8P012G-E201A | 12-Strand | |
| Siemon | 9GD8P024L-E201A | 24-Strand | |
| Siemon | 9GD8P048G-E201A | 48-Strand | |
| Siemon | 9GD8P072G-E201A | 72-Strand | |
| Singlemode Optical Fiber – Outside Plant (OSP) | | | |
| Siemon | 9PE8C006D-E201A | 6-Strand | |
| Siemon | 9PE8C012G-E201A | 12-Strand | |
| Siemon | 9PE8C024L-E201A | 24-Strand | |
| Siemon | 9PE8C048G-E201A | 48-Strand | |
| Siemon | 9PE8C072G-E201A | 72-Strand | |
| Siemon | 9PE8C0144G-E201A | 144-Strand | |
| Singlemode Optical Fiber –Indoor Plenum | | | |
| Siemon | 9BB8P006D-E205A | 6-Strand | |
| Siemon | 9BB8P012G-E205A | 12-Strand | |
| Siemon | 9BB8P024L-E205A | 24-Strand | |
| Siemon | 9BB8P048G-E205A | 48-Strand | |
| Siemon | 9BB8P072G-E205A | 72-Strand | |
| Siemon | 9BB8P0144G-E205A | 144-Strand | |
| Singlemode Optical Fiber – Indoor Interlocking Armored | | | |
| Siemon | 9BC8P006D-E205A | 6-Strand | |
| Siemon | 9BC8P012D-E205A | 12-Strand | |
| Siemon | 9BC8P024D-E205A | 24-Strand | |
| Siemon | 9BC8P048D-E205A | 48-Strand | |
| Siemon | 9BC8P072D-E205A | 72-Strand | |
| Siemon | 9BC8P096D-E205A | 96-Strand | |

| | | | |
|--|------------------|--|--|
| Siemon | 9BC8P0144D-E205A | 144-Strand | |
| Multimode OM3 Optical Fiber –Indoor Plenum | | | |
| Siemon | 9BB5P006D-T312A | 6-Strand | |
| Siemon | 9BB5P012D-T312A | 12-Strand | |
| Siemon | 9BB5P024L-T312A | 24-Strand | |
| Siemon | 9BB5P048G-T312A | 48-Strand | |
| Siemon | 9BB5P072G-T312A | 72-Strand | |
| Siemon | 9BB5P096G-T312A | 96-Strand | |
| Siemon | 9BB5P0144G-T312A | 144-Strand | |
| Multimode OM4 Optical Fiber –Indoor Plenum | | | |
| Siemon | 9BB5P006D-T512A | 6-Strand | |
| Siemon | 9BB5P012G-T512A | 12-Strand | |
| Siemon | 9BB5P024G-T512A | 24-Strand | |
| Siemon | 9BB5P048G-T512A | 48-Strand | |
| Siemon | 9BB5P072G-T512A | 72-Strand | |
| Siemon | 9BB5P096G-T512A | 96-Strand | |
| Siemon | 9BB5P0144G-T512A | 144-Strand | |
| Multimode OM3 Optical Fiber –Indoor Interlocking Armored | | | |
| Siemon | 9BC5P006D-T312A | 6-Strand | |
| Siemon | 9BC5P012D-T312A | 12-Strand | |
| Siemon | 9BC5P024D-T312A | 24-Strand | |
| Siemon | 9BC5P048D-T312A | 48-Strand | |
| Siemon | 9BC5P072D-T312A | 72-Strand | |
| Siemon | 9BC5P096D-T312A | 96-Strand | |
| Siemon | 9BC5P0144D-T312A | 144-Strand | |
| Multimode OM4 Optical Fiber – Indoor Interlocking Armored | | | |
| Siemon | 9BC5P006D-T512A | 6-Strand | |
| Siemon | 9BC5P012D-T512A | 12-Strand | |
| Siemon | 9BC5P024D-T512A | 24-Strand | |
| Siemon | 9BC5P048D-T512A | 48-Strand | |
| Siemon | 9BC5P072D-T512A | 72-Strand | |
| Siemon | 9BC5P096D-T512A | 96-Strand | |
| Siemon | 9BC5P144D-T512A | 144-Strand | |
| SingleMode Pre-Polished Connectors- LC | | | |
| Siemon | FC1-LB-LCU-9BL | Siemon Singlemode LightBow™ LC Connectors | |
| MultiMode Pre-Polished Connectors- LC | | | |
| Siemon | FC1-LB-LC5-9AQ | Siemon Multimode LC LightBow™ Connectors | |
| SingleMode Pigtails | | | |
| Siemon | FPBT12LCUL01 | 12 Strand- Siemon XGLO LC Singlemode Fiber | |
| Siemon | FPBT24LCUL01 | 24 Strand- Siemon XGLO LC Singlemode Fiber | |

| MultiMode Pigtails- OM3 / OM4 | | | |
|--|-------------------|--|--|
| Siemon | FPBT12LC5L01 | 12 Strand- OM3- Siemon XGLO LC Multimode Fiber | |
| Siemon | FPBT24LC5L01 | 24 Strand- OM3- Siemon XGLO LC Multimode Fiber | |
| Siemon | FPBT12LC5V01 | 12 Strand- OM4- Siemon XGLO LC Multimode Fiber | |
| Siemon | FPBT24LC5V01 | 24 Strand- OM4- Siemon XGLO LC Multimode Fiber | |
| Fiber Fusion Splice Trays | | | |
| Siemon | TRAY-3 | Siemon Standard Splice Trays | |
| Fiber Fusion Splice Protection Sleeves | | | |
| Siemon | HT-40 and HT-60 | Siemon Heat Shrink Protection Sleeves | |
| Fiber Rack-Mount Enclosures – 2U, 3U & 4U | | | |
| Siemon | FCP3DWR | 1U Enclosures | |
| Siemon | RIC3-24-01 | 2U Enclosures | |
| Siemon | RIC3-48-01 | 3U Enclosures | |
| Siemon | RIC3-72-01 | 4U Enclosures | |
| XGLOä LC BladePatch® Singlemode Fiber Jumpers | | | |
| Siemon | FBP-LCULCUL-(XX) | Siemon XGLOä LC BladePatch® Singlemode Fiber Jumpers | Use (XX) to specify length: 01 = 1-Meter, 02 = 2-Meters, 03 = 3-Meters, 05 = 5-Meters. |
| Siemon | FBP-LCULCU-(XX)P | Siemon XGLOä LC BladePatch® Singlemode Fiber Jumpers | |
| XGLOä LC BladePatch® Multimode Fiber Jumpers | | | |
| Siemon | FBP-LCLC5L-(XX)AQ | OFNR Jacket OM3 | Use (XX) to specify length: 01 = 1-Meter, 02 = 2-Meters, 03 = 3-Meters, 05 = 5-Meters. |
| Siemon | FBP-LCLC5L-(XX)AP | OFNP Jacket OM3 | |
| Siemon | FBP-LCLC5V-(XX)AQ | OFNR Jacket OM4 | |
| Siemon | FBP-LCLC5V-(XX)AP | OFNP Jacket OM4 | |
| Vertical Cable Managers (VCM) | | | |
| Siemon | VCM-(XX) | Single-Sided | Replace XX with 6 for 6" Wide, 10 for 10" Wide, 12 for 12" Wide, 16 for 16" Wide |
| Siemon | VCM-(XX)D | Double-Sided | |
| Horizontal Cable Managers | | | |
| Siemon | HCM-6-(X)U | Single-Sided Horizontal Cable Manger, 6" depth | Replace 2nd. "X" Specify Height (1 = 1U, 2 = 2U, 4 = 4U) |
| Siemon | HCM-4-(X)U | Single-Sided Horizontal Cable Manger, 4" depth | |
| Siemon | HCME-6-(X)U | Double-Sided Horizontal Cable Manger, 6" depth | |
| Siemon | HCME-4-(X)U | Double-Sided Horizontal Cable Manger, 4" depth | |

EXHIBIT IV**COUNTY'S CHANGE MANAGEMENT**

Best Practice Approach

Below is a list of defined policies specific to this process. These policies provide the formally documented expectations and intentions used to direct decision making and ensure consistent and appropriate implementation of this process.

1. Change Management process will comply with applicable County of Orange policies and standards.
2. Financial approval will be obtained per IT department policy prior to submitting an Change Request (CR) for review and approval.
3. The Change Management process will not include procurement/purchasing review and approval activity.
4. A CR will be recorded in the Change Management system with a unique identification number and viewable in a calendar-based report called a Forward Schedule of Change (FSC).
5. There are three change types: Normal, Routine and Emergency.

- **Normal CRs –**

A Normal change is a non-emergency change that needs to be reviewed by Change Management. Normal Changes are defined as: normal, run of the mill (not “Routine”) and non-emergency Changes that require full Change Management review/approval. Normal Changes are planned out with a clear scope of work. All Normal Changes must be approved by the Agency and the CI Owner and Support groups in order for work to begin.

In order for a change request to qualify as a Normal change request, in our environment, it must meet the following requirements:

- 1) Scope of change can be anything that alters the environment
- 2) Can be any day of the week
- 3) Can be any time during the day
- 4) Implementation, Backout and Test plans are required
- 5) An outage may or may not be required
- 6) Submitted for approval more than 7 days from Planned Implementation Date

All Normal Change Requests are discussed and reviewed in the CAB meeting with the Engineers and Agency representatives.

- **Routine CRs –**

A Routine change must have a documented process that has been reviewed and approved by the Change Approval Board (CAB). Routine Change Requests are defined as pre-approved changes that are considered relatively low risk, are same scope activities performed frequently during a similar timeframe and follow a documented (Change Management approved) process. Think standard, as in, ‘done according to the approved, standard process’; not standard, as in run-of-the-mill.

In order for a change request to qualify as a Routine change request, in our environment, it must meet the following requirements:

- 1) Scope of change item needs to be exactly the same as defined in the routine change
- 2) Day of change (specific day or days) is the same as defined in the routine change
- 3) Start time/stop time of change is the same as defined in the routine change
- 4) No outage is required

In order for a routine change to be created in the system, all of the criteria above must be previously agreed upon by the Vendor and the Customer, and we must have secured Customer approval to create a Routine Change Request.

If you have a change request that does NOT meet all of the above requirements, or varies in any one of those criteria, a new change request will need to be submitted for approvals through the regular approval workflow (Normal or Emergency).

- **Emergency CRs –**

An Emergency Change is a change that must be introduced as soon as possible; for example, to resolve a Major Incident (Service/Organization Impacting) or implement a Security patch. Emergency changes should be kept to a minimum as they are generally disruptive to the environment and have a higher risk of being unsuccessful.

An Emergency change is a non-routine change, which may/may not be similar to the scope of changes recorded under the Normal Change Request process. This category of change requires the approval of a member of the Emergency CAB Approver (E-CAB) Group prior to implementation and review by the CAB post-implementation.

In order for a change request to qualify as an Emergency change request, in our environment, it must meet the following requirement:

- Submitted for approval 7 or less days from Planned Implementation Date
6. For application/middleware changes, a separate CR will be required for the following environments, when the environment exists:
 - Development
 - Test
 - Training
 - Stage/QA
 - Production

Changes in the lab environment do not require a CR.

7. Changes to IT assets not under change control, or to non-controlled attributes of a CI will be recorded as a Service Request rather than a CR.
8. All CR shall be approved according to the approval matrix as depicted in the form “OC Change Approval Matrix”.
9. CI Owners should not approve their own CRs.
10. There must be at least 2 members for any approval group.
11. The CAB will be a fixed body of functional management and subject matter expert participant roles with a primary and secondary assigned to each role. Additional participants may be invited by existing board

members to provide subject matter expertise.

- A complete quorum of each role is required for the CAB, email participation is acceptable.
 - CAB participation and roles shall be defined per Change Management procedures.
 - The Change Manager can reschedule a change if there is lack of sufficient knowledge to make an informed decision.
12. The Change Manager has approval authority, with the advice of the CAB, to approve or reject CRs in the change management application.
 13. Change Manager can approve on behalf of any "absent" or "null" approval.
 14. An ad-hoc CAB meeting can be requested outside of the normally scheduled meeting via the Change Manager.
 15. The CAB meeting will be convened weekly.
 16. CAB meeting minutes will be recorded by an attending scribe and made available in an appropriate shared location within 2 business days.
 17. Changes determined as high and very high risk, per the risk assessment tool, require review and approval at a CAB meeting.
 18. The submitter, or their delegate, of a high or very high-risk CR shall attend the CAB meeting to present the case for the change.
 19. CAB docket for the current period will be distributed by the Change Manager via email to the CAB participants on the morning of the CAB meeting. The CAB agenda includes:
 - Verify impact, resources, and risks for each major CR.
 - Provide recommendations related to CR.
 - Advise Change Manager on CR approvals.
 - Review impact and schedule for CRs.
 - Review status of CRs approved in previous meeting, but not yet completed to see if they are on-time/on-budget.
 - Review failed/rolled back changes, unauthorized changes, and changes implemented without a CR.
 - Discuss any modifications to policies, processes, and procedures (Controlled quality documentation).
 - Review of all completed emergency changes since the last CAB.

Impacted Configuration Items (CI) must be identified between the Change Management System and Configuration Management System.

IN WITNESS WHEREOF, the Parties hereto have executed this Contract on the dates opposite their respective signatures:

West Coast Cable, Inc.

Date: April 16, 2021

By _____

John R. Haygood, President

Print Name & Title

(If a corporation, the document must be signed by two corporate officers. The 1st must be either Chairman of the Board, President or any Vice President.)

Date: April 16, 2021

By _____

John A. Haygood, Secretary

Print Name & Title

(If a corporation, the 2nd signature must be either the Secretary, an Assistant Secretary, the Chief Financial Officer, or any Assistant Treasurer.)

COUNTY
COUNTY OF ORANGE,
a political subdivision of the State of California

Date: May 28, 2021

By _____

Print Name Timothy Shears, MA, DPA

Title Deputy Purchasing Agent

Date: _____

APPROVED AS TO FORM

Office of the County Counsel
Orange County, California

By: _____

Deputy

4-19-21

PART II - GENERAL CONDITIONS

Table of Contents

| | | |
|-----|---|----|
| 1. | DEFINITIONS | 59 |
| 2. | COUNTY'S REPRESENTATIVES | 60 |
| 3. | A-E STATUS | 61 |
| 4. | CONTRACTOR | 61 |
| 5. | SUBCONTRACTS | 62 |
| 6. | DRAWINGS AND SPECIFICATIONS | 63 |
| 7. | DIVISION OF THE SPECIFICATIONS | 63 |
| 8. | SITE CONDITIONS | 64 |
| 9. | CONDITIONS AFFECTING THE WORK | 65 |
| 10. | COUNTY'S PROPERTY ON SITE | 65 |
| 11. | PROTECTION | 65 |
| 12. | RESPONSIBILITY FOR DAMAGES OR INJURY | 66 |
| 13. | PAYMENTS..... | 67 |
| 14. | ASSIGNMENT | 67 |
| 15. | OTHER CONTRACTS | 67 |
| 16. | INDEMNIFICATION AND INSURANCE | 67 |
| 17. | CHANGES | 70 |
| 18. | ORAL MODIFICATION | 71 |
| 19. | MATERIAL, WORKMANSHIP AND ACCEPTANCE..... | 71 |
| 20. | TERMINATION FOR CAUSE & DAMAGES FOR DELAY | 72 |
| 21. | TERMINATION FOR CONVENIENCE OF THE COUNTY | 73 |
| 22. | BENEFICIAL OCCUPANCY | 73 |
| 23. | PATENT INFRINGEMENT | 73 |
| 24. | NO WAIVER BY COUNTY | 73 |
| 25. | DISPUTES | 74 |
| 26. | WAGE RATE PENALTY..... | 77 |
| 27. | PAYROLL RECORDS | 77 |
| 28. | WORK HOUR PENALTY..... | 78 |
| 29. | APPRENTICES..... | 78 |
| 30. | NON-DISCRIMINATION | 78 |
| 31. | ASSIGNMENT OF ANTITRUST ACTIONS | 79 |
| 32. | SUBSTITUTED SECURITY | 79 |
| 33. | COST REDUCTION INCENTIVE..... | 79 |
| 34. | WRITTEN NOTICE..... | 81 |

1. DEFINITIONS

As used herein the following terms have the meaning indicated:

- A. Board of Supervisors: The governing body of the County of Orange.
- B. Director: The Director of Orange County Information Technology, County of Orange, or a designated representative for the Project.
- C. County: The County of Orange as a legal entity, a political subdivision of the State of California.
- D. A-E: The Architect or Engineer or his authorized representative retained by the County to design the Project.
- E. The Contract Documents: The Contract Documents consist of County-Contractor Contract, Scope of Work, Certificates of Insurance, General Conditions, Supplementary General Conditions, Drawings, Specifications, and all modifications and amendments thereto.
- F. OCIT: Orange County Information and Technology.
- G. Project: The work to be performed by Contractor on behalf of County pursuant to this Contract.
- H. OC Public Works: OC Public Works, County of Orange
- I. County's Project Manager: County's Project Manager is responsible for planning and monitoring the Project requirements, budget, design, construction, and closeout. They shall coordinate all activities with Project stakeholders including contractor(s), vendors, County Departments, and regulatory agencies. They also serve as primary contact for all stakeholders involved in the Project.
- J. Service Request: An order assigned to Contractor for the execution of a Project under this Contract developed by Contractor in conjunction with the County Project Manager
- K. Additional Acronyms and Definitions:
 1. **AHJ** - Authority Having Jurisdiction
 2. **ANSI** - American National Standards Institute (Standards are located at <http://www.ansi.org/default.aspx>)
 3. **ANSI/TIA** – Telecommunications Industry Association, United States Standards Organizations in Cable Industry
 4. **ANSI/BICSI N1-2019** – Installation Practices for Telecommunications and ICT Cabling and Related Cabling Infrastructure
 5. **AWG** - American Wire Gauge
 6. **CEO/OCIT**- County Executive Office – Orange County Information Technology
 7. **CLEC** - Competitive Local Exchange Carrier: Non-Utility competitive provider of dial tone and telecommunications services (e.g., Time Warner Cable, Cox Cable, TW Telecom (who was acquired by Level 3 Communications on November 1, 2014), etc.)
 8. **Contractor** – Contractor of record or any of its personnel or sub-contractors authorized to provide services hereunder.
 9. **EIA** - Electronic Industries Alliance
 10. **ER** - Equipment Room (Main Distribution Frame room - MDF)
 11. **ILEC** - Local Exchange Carrier: Carrier responsible for local dial tone and telecommunications services (i.e. AT&T or Verizon in Southern California area)
 12. **LIU**- Light Interface Unit. Fiber cable termination point

13. **Managed Services** - Installation and Operational Services provided by an outside Contractor selected by the County
14. **MM** - Multi-Mode Fiber Optic Cable
15. **MPOE** - Minimum Point of Entry: minimum distance entering customer premises where ILEC/CLEC will terminate their equipment. Point of demarcation between Carrier equipment and Customer Equipment;
16. **NEC** - National Electric Code (NEC is located at <http://www.nfpa.org/aboutthecodes/AboutTheCodes.asp?DocNum=70>)
17. **NFPA** - National Fire Protection Association (NFPA is located at <http://www.nfpa.org/>)
18. **OSP** - Outside Plant
19. **OTDR** - Optical Time Domain Reflectometer
20. **Service Request** - a request from County Agency for structured cabling and installation services that was initiated in ServiceNow.
21. **SM** - Single Mode-Fiber Optic Cable
22. **TIA** - Telecommunications Industry Association (located at <http://www.tiaonline.org/>)
23. **TIA/FOCIS** - Telecommunications Industry Association/ Fiber Optic Connector Intermate ability Standard
24. **TR** - Terminal Room (Intermediate Distribution Frame room - IDF)
25. **TSD** - Telephone Services Division (Operational Control of County Legacy Network)
26. **TSS** - Telephone Service Specialist (Personnel responsible for processing Agency service requests)
27. **TSR** - Telephone Service Request (Document used to request MAC services for Legacy Network)

2. COUNTY'S REPRESENTATIVES

- A. The work will be under the general direction of the Board of Supervisors. OCIT is the authorized representative of the Board of Supervisors and, under the Board of Supervisors, has complete charge of the work, and shall exercise full control of the work, so far as it affects the interest of the County.
- B. The provisions in this Article or elsewhere in this Contract regarding approval or direction by the County, Board of Supervisors, or OCIT, or action taken pursuant thereto are not intended to and shall not relieve the Contractor of responsibility for the accomplishment of the work, either as regards sufficiency or the time of performance, except as expressly otherwise provided herein.
- C. County's Project Manager is the County's exclusive contact agent to the Contractor with respect to this Project during construction and until the completion of the Project.
- D. The County's communications with the Contractor and A-E shall be exclusively through the County's Project Manager.
- E. County Project Manager shall at all times have access to the work whenever it is in preparation or progress. The Contractor shall provide safe facilities for such access.
- F. The County and A-E shall not be responsible for or have control or charge of the construction means, methods, techniques, sequences or procedures, or for safety precautions and programs in connection with the work, and will not be responsible for the Contractor's failure to carry out the work in accordance with the Contract Documents.
- G. The County and A-E will not be responsible for the failure of the Contractor to plan, schedule, and execute the work in accordance with the approved schedule or the failure of the Contractor to meet the Contract completion dates or the failure of the Contractor to schedule and coordinate the work of his own trades and subcontractors or to coordinate with others separate Contractors.
- H. The County will not be responsible for the acts or omissions of the Contractor, or any subcontractor, or any Contractor's or subcontractor's agents or employees, or any other persons performing any of the work.
- I. County Project Manager has the authority to disapprove or reject work on behalf of the County when, in the County Project Manager's opinion, the work does not conform to the Contract Documents.

- J. Whenever, in County Project Manager's reasonable opinion, it is considered necessary or advisable to insure the proper implementation of the intent of the Contract Documents, County Project Manager has the authority to require special inspection or testing of any work in accordance with the provisions of the Contract Documents whether or not such work shall then be fabricated, installed or completed.
- K. County Project Manager has the authority to require special inspection or testing of the work. However, neither County Project Manager's authority nor any decision made by the Project Manager in good faith whether to exercise or not to exercise such authority shall give rise to any duty or responsibility of the County to the Contractor, or any subcontractor, or any of their agents, or employees, or any other person performing any portion of the work.
- L. County Project Manager has the authority and discretion to call, schedule, and conduct job meetings to be attended by the Contractor, representatives of his subcontractors and the A-E and its consultants, to discuss such matters as procedures, progress, problems, and scheduling.
- M. County Project Manager will establish procedures to be followed for processing all submittals, Change Orders, Progress payments, other Project reports, documentation and test reports
- N. County Project Manager and A-E will review all requests for changes and shall implement the processing of Change Orders including application for extensions of time.
- O. County Project Manager and A-E will review and process all Progress Payment Requests by the Contractor, including Final Progress Payment Requests.

3. A-E STATUS

Unless otherwise expressly stated in the Contract between the Contractor and the County, the A-E is responsible to the County for the preparation of adequate drawings, specifications, cost estimates, and reports within the scope of his contract. A-E Tasks normally include checking of: shop drawings and material lists; recommendations to the County regarding proposed substitutions; furnishing consultation and advice to the County to clarify the intent of the drawings and specifications and on questions that may arise during construction. A-E shall have access to observe the work at all times wherever it is in preparation or progress. A-E does not have the authority to act for the County or to stop the work. Should A-E observe work which, in its judgment, should be stopped to prevent damage, injury, loss, or error, A-E shall notify the Contractor and the County Project Manager without delay.

4. CONTRACTOR

- A. Composition: If the Contractor is comprised of more than one legal entity, each such entity shall be jointly and severally liable hereunder.
- B. Review Documents: The Contractor shall carefully study and compare all drawings, specifications, and other instructions and shall at once report to the County Project Manager any error, inconsistency, or omission which it may discover but Contractor shall not be liable to the County for any damage resulting from any errors or deficiencies in the contract documents or other instructions by the County if the provisions hereinafter set forth are carried out by Contractor. Except as otherwise specifically provided hereinafter under warranties, the Contractor shall not be an agent for the County.
- C. Superintendence: The Contractor shall maintain on site, at all times during the construction activities, a competent Superintendent. In addition to a General Superintendent and other administrative and supervisory personnel required for the performance of the work, the Contractor shall provide specific coordinating personnel as reasonably required for interfacing of all the work required for the total Project, all satisfactory to County Project Manager. The superintendent shall not be changed except with consent of County Project Manager, unless the superintendent proves to be unsatisfactory to the Contractor and ceases to be in his employ, in which case he shall be replaced within 24 hours by a superintendent acceptable to County Project Manager. The superintendent shall represent the Contractor in its absence

and all directions given to superintendent shall be binding as if given to the Contractor.

- D. Licenses and Certificates: Contractor shall, at all times during the term of this Contract, maintain in full force and effect such licenses as may be required by the State of California or any other governmental entity for Contractor to perform the duties specified herein and provide the Tasks required pursuant to this Contract. Contractor shall strictly adhere to, and obey all governmental rules and regulations now in effect or as subsequently enacted or modified, as promulgated by any local, state, or federal governmental entities.
- E. Superintendence and Project Manager: The Contractor shall provide County Project Manager with complete work history profiles of management staff associated with this Project for County Project Manager review.
- F. Contractor's Completion Schedule: The Contractor, after being awarded the Contract, shall prepare and submit, for County Project Manager approval, a Construction Schedule for the work which shall provide for expeditious and practicable execution of the work for completion within the Contract Time. This schedule shall be coordinated with the entire Project Construction Schedule to the extent required by the Contract Documents.
- G. Employee Eligibility Verification: The Contractor shall warrant that it fully complies with all Federal and State statutes and regulations regarding the employment of aliens and others and that all its employees performing work under this Contract meet the citizenship or alien status requirement set forth in Federal statutes and regulations. The Contractor shall obtain, from all employees performing work hereunder, all verification and other documentation of employment eligibility status required by Federal or State statutes and regulations including, but not limited to, the Immigration Reform and Control Act of 1986, 8 U.S.C. §1324 et seq., as they currently exist and as they may be hereafter amended. The Contractor shall retain all such documentation for all covered employees for the period prescribed by the law. The Contractor shall indemnify, defend with counsel approved in writing by County, and hold harmless, the County, its agents, officers, and employees from employer sanctions and any other liability which may be assessed against the Contractor or the County or both in connection with any alleged violation of any Federal or State statutes or regulations pertaining to the eligibility for employment of any persons performing work under this Contract.

5. DRAWINGS AND SPECIFICATIONS

- A. Checking: The Contractor shall check all drawings and specifications furnished to it immediately upon receipt and shall promptly notify County Project Manager of any discrepancies. Figures marked on drawings shall in general be followed in preference to scale measurements. Large-scale drawings shall in general govern small-scale drawings. Door, finish hardware; etc., schedules shall govern over drawings. The Contractor shall compare all drawings and verify the figures before laying out the work and will be responsible for any errors, which might have been avoided thereby. When measurements are affected by conditions already established, the Contractor shall take measurements notwithstanding the giving of scale or figure dimensions in the drawings. Anything mentioned in the specifications and not shown on the drawings or shown on the drawings and not mentioned in the specifications, shall be of like effect as if shown or mentioned in both.
- B. Omissions and Misdescriptions: Omissions from the drawings or specifications or the misdescription of details of work which are manifestly necessary to carry out the intent of the drawings and specifications, or which are customarily performed, shall be called to the attention of County Project Manager as soon as possible. County Project Manager shall promptly notify the Contractor of the correction or addition to be made. In the event the omission or misdirection is substantial and the custom of the trade or industry does not require the Contractor to perform the work without additional charge, County Project Manager may issue an additive or deductive change order therefore and the Contractor shall be compensated in the

manner herein provided for change orders. Any adjustment by the Contractor without written determination shall be at Contractor's own risk and expense.

- C. **Conflicting Information:** In case of conflict between sections of the specifications and/or the drawings, the Contractor shall bid the most expensive alternate.
- D. **Drawings and Specifications at the Site:** The Contractor shall keep available at the site for ready reference a complete set of all contract drawings, details, supplementary drawings and approved shop drawings, a complete copy of the specifications with all addenda, bulletins, amendments, and copies of project correspondence.

The Contractor shall maintain on the site a complete "as-built" record set of prints. In addition, the Contractor shall keep on the site as required a copy of each manufacturer's current printed recommendations. Contractor shall also submit a copy to County Project Manager.

- E. **Deviations:** Deviations from the drawings and the dimensions therein given, whether or not error is believed to exist, shall be made only after written authority is obtained from County Project Manager.
- F. Contractor shall carefully review all Requests for Information (RFI's) prior to submission to A-E. RFI's shall be clearly legible, shall be specific, and shall include supporting sketches or information necessary to properly convey requested information. Contractor shall submit recommended solution(s) for A-E's review and consideration.

6. DIVISION OF THE SPECIFICATIONS

- A. For convenience, these specifications are arranged in several divisions and sections, but such separations shall not be considered as the limits of the work required for any subcontract or trade; the terms and conditions of such limitations are wholly between the Contractor and its subcontractors, and the County will not be responsible for any division of work by subcontractors. The Contractor will be solely responsible for all subcontract arrangements work regardless of the location of provisions in the specifications.
- B. Schedules of work included in the sections, where listed, are given for convenience only, and shall not be considered as a comprehensive list of items or work necessary to complete the work of any section.
- C. Where devices or items or parts thereof are referred to in the singular, it is intended that such reference shall apply to as many such devices, items, or parts as are required to properly complete the work.
- D. Each section of the specifications is covered by applicable requirements of the Contract Documents and other related sections as if therein written.

7. SITE CONDITIONS

- A. **Existing Site Conditions:** Information with respect to the site of the work given in drawings or specifications has been obtained by County's representatives and is believed to be reasonably correct, but the County does not warrant either the completeness or accuracy of such information, and it is the responsibility of the Contractor to verify all such information.
- B. **Changed Conditions:** The Contractor shall promptly, and before such conditions are disturbed, notify the County Project Manager in writing of:
 - (1) Subsurface or latent physical conditions at the site differing materially from those indicated in this contract, or

- (2) Unknown physical conditions at the site, of an unusual nature, differing materially from those ordinarily encountered and generally recognized as inherent in work of the character provided for in this Contract.
- (3) Material that the Contractor believes may be material that is hazardous waste, as defined in Section 25117 of the Health and Safety Code that is required to be removed to a Class I, Class II or Class III disposal site in accordance with provisions of existing law.
- (4) County Project Manager will promptly investigate the conditions, and if, as a result, finds that such conditions do so materially differ and cause an increase or decrease in the Contractor's cost of, or the time required or performance of this contract, an equitable adjustment in accordance with Article 18 shall be made and the Contract modified in writing accordingly. Any claim of the Contractor for adjustment hereunder shall not be allowed unless he has given notice as above required.

In the event that a dispute arises between the County and the Contractor whether the conditions materially differ, or involve hazardous waste, or cause a decrease or increase in the Contractor's cost of, or, time required for, performance of any part of the work, the Contractor shall not be excused from any scheduled completion date provided for by the Contract, but shall proceed with all work to be performed under the Contract. The Contractor shall retain any and all rights provided either by Contract or by law which pertain to the resolution of disputes and protests between the contracting parties.

- C. Public Utility Facilities on Project Site: Pursuant to Government Code, Section 4215, the Contractor shall be compensated for the costs of locating and repairing damage not due to failure of Contractor to exercise reasonable care, and removing, relocating existing or protecting existing main or trunk line utility facilities located on the contract construction site and not identified in the plans or specifications with reasonable accuracy. Such compensation shall also cover the cost of Contractor's equipment necessarily idled during such work. This provision shall not be deemed to require compensation when the presence of existing Task laterals or appurtenances can be inferred from the presence of visible facilities such as buildings, meter and junction boxes on or adjacent to the construction site. If the Contractor discovers such unidentified utility facilities during construction, he shall immediately notify County Project Manager and the utility in writing.
- D. Space at Site: The Contractor shall be allowed reasonable space at the site of the work as available and access thereto and shall confine his operations to the space assigned. The work shall be done without interference with the ordinary use of streets, berthing places, fairways, and passages. The Contractor shall cooperate with other Contractors of the County and shall not commit or permit any act which will interfere with the performance of work by any other Contractor or employees of the County whether at the site or not.
- E. Facility Security: Contractor shall keep all doors locked while working in any buildings on the site. Keys shall not be left in the doors. Contractor shall not admit any person into the building that is not a direct employee of the Contractor and not actively engaged in performance of the work. Contractor shall restrict access to the areas of the facility not specifically included in this contract for construction Tasks. The Contractor shall check all windows and doors for proper closure and locking, extinguish all lights except master security lighting, and then reactivate the security system (if applicable) prior to leaving the facility.
- F. Security System: The site and the work area may be protected by limited access security systems. An initial access code number will be issued to the contractor by the County. Thereafter, all costs for changing the access code due to changes in personnel or required substitution of contracts shall be paid by the Contractor and may be deducted from payments due or to become due to the contractor. Furthermore, any alarms originating from the contractor's operations shall also be paid by the Contractor and may be deducted from

payments due or to become due to the Contractor.

- G. Employee Acceptability: Prior to commencing any construction at the site, Contractor shall obtain security clearances of all persons and/or entities it intends to employ for this Project. During the life of the Project, Contractor shall remove and replace any employee working on this Project when requested to do so by the County.

8. CONDITIONS AFFECTING THE WORK

The Contractor shall be responsible for having taken steps reasonably necessary to ascertain the nature and location of the work, and the general and local conditions, which can affect the work or the cost thereof. Any failure by the Contractor to do so will not relieve it from responsibility for successfully performing the work without additional expense to the County. The County assumes no responsibility for any understanding or representations concerning conditions made by any of its officers or agents prior to the execution of this Contract, unless such understanding or representations by the County are expressly stated in the Contract.

9. COUNTY'S PROPERTY ON SITE

All fixtures, crops, trees, and all other personal property of the County located at the job site which are removed in the course of construction of the Project remain the property of the County unless express provision to the contrary is made in the Contract between the parties, and the Contractor shall exercise reasonable care to prevent loss or damage to said property and shall deliver promptly such property to the place designated by the County.

10. PROTECTION

- A. The Contractor shall take proper safety and health precautions to protect the work, the workers, the public, and the property of others. Contractor shall comply with the provisions of the Construction Safety Orders issued by the State Division of Occupational Safety & Health. Contractor shall also be responsible for all materials delivered and work performed until completion and acceptance of the entire construction work, except for any completed unit of construction thereof which until completion and acceptance of the entire construction work, except for any completed unit of construction thereof which theretofore may have been accepted.
- B. The Contractor shall maintain continuously adequate protection of its work from damage and shall protect the County's property from injury or loss arising in connection with this Contract. Contractor shall make good any such damage, injury or loss, except such as may be directly due to errors in the contract documents or caused by agents or representatives of the County. Contractor shall adequately protect adjacent property as provided by law and the contract documents and shall maintain reasonable security of the site at all times. Contractor shall limit visitors to the site to those necessary for construction and inspections. Visitors for other purposes shall be referred to OCIT. Contractor's and subcontractors' employees shall possess means of identification at all times as required by OCIT while on the job site.
- C. In an emergency affecting the safety of life or of the work or of adjoining property, the Contractor, without special instruction or authorization from the A-E or County, is hereby permitted to act at his discretion to prevent such threatened loss or injury. Contractor shall so act if directed or instructed by the County. Any dispute as to compensation claimed by the Contractor on account of emergency work shall be determined by agreement as hereinafter set forth.
- D. The County may notify the Contractor of any noncompliance with the foregoing provisions and the action to be taken. The Contractor shall, after receipt of such notice, immediately correct such conditions. Such notices, when delivered to the Contractor or his representative at the site of the work, shall be deemed sufficient for said purpose. Failure of receipt of such notice from the County shall not relieve the Contractor of responsibility.

- E. If the Contractor fails or refuses to comply promptly, the County may issue an order stopping all or part of the work until satisfactory corrective action has been taken. No part of the time lost due to any such stop order shall be made the subject of claim for extension of time or for excess costs or damages to the Contractor. The Contractor will be responsible for ensuring that his subcontractors comply with the provisions of this Article.

11. RESPONSIBILITY FOR DAMAGES OR INJURY

- A. The County and all officers and employees thereof shall not be answerable or accountable in any manner for any loss or damage that may happen to the work or any part thereof; for any loss or damage to any of the materials or other things used or employed in performing the work; for injury to or death of any person either workers or the public; or for damage to property from any cause which might have been prevented by the Contractor, or his workers, or anyone employed by him.
- B. The Contractor shall be responsible for any liability imposed by law and for injuries to or death of any person or damage to property resulting from defects or obstructions or from any cause whatsoever during the progress of the work or at any time before its completion and final acceptance.
- C. In accordance with Section 16 below, the Contractor shall indemnify, defend with counsel approved in writing by County and save harmless the County and all officers and employees thereof connected with the work, from all claims, suits or actions of every name, kind and description, brought for, or on account of, injuries to or death of any person or damage to property resulting from the construction of the work or by or in consequence of any negligence in guarding the work; use of improper materials in construction of the work; or by or on account of any act or omission by the Contractor or his agents during the progress of the work or at any time before its completion and final acceptance.
- D. In addition to any remedy authorized by law, so much of the money due the Contractor under and by virtue of the Contract as shall be considered necessary by the County may be retained by it until disposition has been made of such suits or claims for damages as aforesaid.

12. PAYMENTS

- A. The County shall make payments upon the contract price in accordance with Article 5 of the Contract and as hereinafter provided.
- B. Public Works Projects from \$5,000 to \$75,000 shall be paid by progress payments or by payment upon completion of the work as established in the Contract. County may process payment(s) up to 95 percent of the actual value of the work completed. Not less than 5 percent shall be withheld until the work is complete. Retention shall be released in accordance with Public Contract Code Section 7107. Final payment shall be issued based on the completion of the work as described in this Contract and the Project Manager accepting all the work. Partial payments may be allowed at discretion of the County of Orange Project Manager.

13. ASSIGNMENT

Neither the Contract nor any portion thereof may be assigned by the Contractor without the expressed permission of the County. Claims for monies due or to become due the Contractor from the County under this Contract may be assigned, with the written consent of the Director, to a bank, trust company, or other financing institution and may thereafter be further assigned or reassigned to any such institution. To effect such assignments, the Contractor, or its assignee, shall submit a written request to the County's Project Manager enclosing a letter from the proposed assignee indicating that it will accept such assignment. Any attempted assignment contrary to the provisions of this Article shall be void.

14. OTHER CONTRACTS

The Board of Supervisors may undertake or award other contracts for additional work, and the Contractor shall fully cooperate with such other contractors and County employees and carefully fit its own work to such additional work as may be directed by the County. The Contractor shall not commit or permit any act, which will interfere with the performance of work by any other contractor or by County employees.

15. INDEMNIFICATION AND INSURANCE

INDEMNIFICATION PROVISIONS

Contractor agrees to indemnify, defend with counsel approved in writing by County, and hold County, their elected and appointed officials, officers, employees, agents and those special districts and agencies which County's Board of Supervisors acts as the governing Board ("County Indemnitees") harmless from any claims, demands or liability of any kind or nature, including but not limited to personal injury or property damage, arising from or related to the Tasks, products or other performance provided by Contractor pursuant to this Contract. If judgment is entered against Contractor and County by a court of competent jurisdiction because of the concurrent active negligence of County or County Indemnitees, Contractor and County agree that liability will be apportioned as determined by the court. Neither party shall request a jury apportionment. Notwithstanding anything stated above, nothing contained herein shall relieve Contractor of any insurance requirements or obligations created elsewhere in this contract.

INSURANCE PROVISIONS

Prior to the provision of Tasks under this Contract, the Contractor agrees to purchase all required insurance at Contractor's expense, including all endorsements required herein, necessary to satisfy the County that the insurance provisions of this Contract have been complied with. Contractor agrees to keep such insurance coverage, Certificates of Insurance, and endorsements on deposit with the County during the entire term of this Contract. The County reserves the right to request the declarations pages showing all endorsements and a complete certified copy of the policy. In addition, all subcontractors performing work on behalf of Contractor pursuant to this Contract shall obtain insurance subject to the same terms and conditions as set forth herein for Contractor.

Contractor shall ensure that all subcontractors performing work on behalf of Contractor pursuant to this Contract shall be covered under Contractor's insurance as an Additional Insured or maintain insurance subject to the same terms and conditions as set forth herein for Contractor. Contractor shall not allow subcontractors to work if subcontractors have less than the level of coverage required by County from Contractor under this Contract. It is the obligation of Contractor to provide notice of the insurance requirements to every subcontractor and to receive proof of insurance prior to allowing any subcontractor to begin work. Such proof of insurance must be maintained by Contractor through the entirety of this Contract for inspection by County representative(s) at any reasonable time.

All self-insured retentions (SIRs) shall be clearly stated on the Certificate of Insurance. Any self-insured retention (SIR) in an amount in excess of Fifty Thousand Dollars (\$50,000) shall specifically be approved by the County's Risk Manager, or designee, upon review of Contractor's current audited financial report. If Contractor's SIR is approved, Contractor, in addition to, and without limitation of, any other indemnity provision(s) in this Contract, agrees to all of the following:

- 1) In addition to the duty to indemnify and hold the County harmless against any and all liability, claim, demand or suit resulting from Contractor's, its agents, employee's or subcontractor's performance of this Contract, Contractor shall defend the County at its sole cost and expense with counsel approved by Board of Supervisors against same; and

- 2) Contractor's duty to defend, as stated above, shall be absolute and irrespective of any duty to indemnify or hold harmless; and
- 3) The provisions of California Civil Code Section 2860 shall apply to any and all actions to which the duty to defend stated above applies, and the Contractor's SIR provision shall be interpreted as though the Contractor was an insurer and the County was the insured.

Upon notice of any actual or alleged claim or loss arising out of subcontractor's work hereunder, subcontractor shall immediately satisfy in full the SIR provisions of the policy in order to trigger coverage for the Contractor and Additional Insureds.

If the Contractor fails to maintain insurance acceptable to the County for the full term of this Contract, the County may terminate this Contract.

Qualified Insurer

The policy or policies of insurance must be issued by an insurer with a minimum rating of A- (Secure A.M. Best's Rating) and VIII (Financial Size Category as determined by the most current edition of the **Best's Key Rating Guide/Property-Casualty/United States or ambest.com**). It is preferred, but not mandatory, that the insurer be licensed to do business in the state of California (California Admitted Carrier).

If the insurance carrier does not have an A.M. Best Rating of A-/VIII, the CEO/Office of Risk Management retains the right to approve or reject a carrier after a review of the company's performance and financial ratings. The policy or policies of insurance maintained by the Contractor shall provide the minimum limits and coverage as set forth below:

| <u>Coverage</u> | <u>Minimum Limits</u> |
|---|---|
| Commercial General Liability | \$3,000,000 per occurrence |
| Automobile Liability including coverage for owned, non-owned and hired vehicles | \$3,000,000 aggregate \$1,000,000 per occurrence |
| Workers' Compensation | Statutory |
| Employers' Liability Insurance | \$1,000,000 per occurrence |

Required Coverage Forms

The Commercial General Liability coverage shall be written on Insurance Tasks Office (ISO) form CG 00 01, or a substitute form providing liability coverage at least as broad.

The Business Auto Liability coverage shall be written on ISO form CA 00 01, CA 00 05, CA 00 12, CA 00 20, or a substitute form providing liability coverage as broad.

Required Endorsements

The Commercial General Liability policy shall contain the following endorsements, which shall accompany the Certificate of Insurance:

- 1) An Additional Insured endorsement using ISO form CG 2010 or CG 2033 or a form at least as broad naming the *County of Orange, it's elected and appointed officials, officers, employees and agents* as Additional Insureds, or provide blanket coverage which shall state ***AS REQUIRED BY WRITTEN CONTRACT.***
- 2) A primary non-contributing endorsement evidencing that the Contractor's insurance is primary and any insurance or self-insurance maintained by the County of Orange shall be excess and non-contributing.

- 3) A Products and Completed Operations endorsement using ISO Form CG2037 (ed. 10/01) or a form at least as broad, or an acceptable alternative is the ISO from CG2010 (ed. 11/85).

The Workers' Compensation policy shall contain a waiver of subrogation endorsement waiving all rights of subrogation against the *County of Orange, its elected and appointed officials, officers, employees and agents* or provide blanket coverage which shall state **AS REQUIRED BY WRITTEN CONTRACT** when acting within the scope of their appointment or employment.

All insurance policies required by this Contract shall waive all rights of subrogation against the County of Orange, its elected and appointed officials, officers, employees and agents when acting within the scope of their appointment or employment.

Contractor shall notify County in writing within thirty (30) days of any policy cancellation and ten (10) days for non-payment of premium and provide a copy of the cancellation notice to County. Failure to provide written notice of cancellation may constitute a material breach of the Contract, upon which the County may suspend or terminate this Contract.

The Commercial General Liability policy shall contain a severability of interests Article (standard in the ISO CG 001 policy).

Insurance certificates should be forwarded to the agency/department address listed on the solicitation. If the Contractor fails to provide the insurance certificates and endorsements within seven (7) days of notification by CEO/Purchasing or the agency/department purchasing division, award may be made to the next qualified Contractor.

County expressly retains the right to require Contractor to increase or decrease insurance of any of the above insurance types throughout the term of this Contract. Any increase or decrease in insurance will be as deemed by County of Orange Risk Manager as appropriate to adequately protect County.

County shall notify Contractor in writing of changes in the insurance requirements. If Contractor does not deposit copies of acceptable certificates of insurance and endorsements with County incorporating such changes within thirty days of receipt of such notice, this Contract may be in breach without further notice to Contractor, and County shall be entitled to all legal remedies.

The procuring of such required policy or policies of insurance shall not be construed to limit Contractor's liability hereunder nor to fulfill the indemnification provisions and requirements of this Contract, nor in any way to reduce the policy coverage and limits available from the insurer.

16. CHANGES

- A. The Board of Supervisors may, at any time, by written order, and without notice to the sureties, make changes in the drawings or specifications of this Contract if within the general scope thereof. If such changes cause an increase or decrease in the Contractor's cost, or the time required for performance of the Contract, and equitable adjustment shall be made and the Contract modified in writing accordingly by the County and Contractor.
- B. The cost or credit to the County resulting from a change in the work shall be calculated by using the unit prices in the Contract Documents, if there are any, otherwise it shall be determined in the following manner:
- (1) By mutual acceptance of a lump sum cost properly itemized and supported by sufficient substantiating data as the County Project Manager may require to permit evaluation.

For the purposes of this Article, "cost" shall be determined as follows-by the Contractor's cost proposal and the County's acceptance. Contractor's proposal must include the following breakdown and shall not exceed the total actual cost of the items listed below.

- (a) Cost of materials and supplies (list unit cost and quantity)
 - (b) Cost of labor (show hourly rate x hours)
 - (c) Sales tax on materials [percentage of (a)]
 - (d) Payroll tax on labor [percentage of (b)]
 - (e) Insurance [Provide complete documentation relating to increase in insurance due this change. In no case shall the percentage be greater than 2% of (a) through (d).]
 - (f) Overhead and profit [maximum as defined in Subarticle s F., G. and H. on (a) through (d)]
- C. OCPW is authorized by the Board of Supervisors to make, by written order, changes or additions to the work within the scope of this Contract. This authority to approve changes is limited to an amount not to exceed Five Thousand Dollars (\$5,000) for original contracts of up to Fifty Thousand Dollars (\$50,000), or ten percent (10%) of the amount of any original contract which exceeds Fifty Thousand Dollars (\$50,000 but does not exceed Two Hundred Fifty Thousand Dollars (\$250,000) per each change. For original contracts exceeding Two Hundred Fifty Thousand Dollars (\$250,000), the amount shall not exceed Twenty-Five Thousand Dollars (\$25,000), plus five percent (5%) of the amount of the original contract in excess of Two Hundred Fifty Thousand Dollars (\$250,000), up to a maximum of Two Hundred Ten Thousand Dollars (\$210,000) per each change. All changes over the amounts specified above shall be subject to the approval of the Board of Supervisors.
- D. Any claim of the Contractor for adjustment under this Article must be asserted in writing within 30 days from the date of receipt by the Contractor of the notification of change unless the Board of Supervisors or OCIT grants a further period of time before the date of final payment under the Contract.
- Nothing provided in this Article should excuse the Contractor from proceeding with the prosecution of the work as changed. Except as otherwise provided in this Contract, no charge for any extra work or material will be allowed.
- E. Labor wage rates shall not exceed the Prevailing Wage Rates supported by payroll records. Equipment rental rates should be based on latest edition of equipment rental rates published by the State of California Department of Transportation; Division of Construction.
- F. For the purposes of Subarticle B, overhead shall include the following: bond premiums, supervision, superintendence, scheduling, wages of timekeepers, watchmen and clerks, small tools, incidentals, field and home office expenses, preparation and estimating costs for change orders, and all other expenses not included in "cost" ... such as "Learning Curves" and "Productivity Factors", etc.
- G. For the purposes of Subarticle B, overhead and profit combined included in the total cost to the County of any change shall not exceed the rates set forth in the following schedule:
- (1) For work performed by the Contractor and his own forces, 15% of cost.
 - (2) For work performed by Subcontractor forces:
 - (a) 15% of the cost to the Subcontractor,

(b) 6% of the cost to the General Contractor.

H. If the net value of a change results in a credit from the Contractor or Subcontractor, the credit given shall be the net cost without overhead or profit. If the net value of a change results in additional costs, overhead and profit will only be applied to the difference of the added change and credited amount.

I. Nothing in this Article shall excuse the Contractor from proceeding with the Contract or changes.

17. ORAL MODIFICATION

No oral statement of any person whomsoever, shall in any manner or degree, modify or otherwise affect the terms of this Contract.

18. MATERIAL, WORKMANSHIP AND ACCEPTANCE

- A. Where materials are specified by reference to standard specifications of the American Society for Testing Materials (A.S.T.M.), Federal Specifications, or others, all applicable provisions of the designated specifications shall be considered as forming a part of the Contract Documents to the same force and effect as if repeated therein.
- B. All work under this Contract shall be performed in a skillful and workman like manner. the County may, in writing, require the Contractor to remove from the work any employee County Project Manager deems incompetent, careless, or otherwise objectionable.
- C. The Contractor shall, without charge, replace any material or correct any workmanship found by the County not to conform to the contract requirements, unless in the public interest the County consents to accept such material or workmanship with an appropriate adjustment in contract price. The Contractor shall promptly segregate and remove rejected material from the premises.
- D. If the Contractor does not promptly replace rejected material or correct rejected workmanship, the County (1) may, by contract or otherwise, replace such material or correct such workmanship and charge the cost thereof to the Contractor, or (2) may terminate the Contractor's right to proceed in accordance with Article 20 or 21 of these General Conditions.
- E. Unless otherwise provided in this Contract, acceptance by the County shall be accomplished by recordation of Notice of Completion which shall be made as promptly as practicable after completion and inspection of all work required by this Contract. Acceptance shall be final and conclusive except as regards latent defects, fraud, or such gross mistakes as may amount to fraud, or as regards the County's rights under any warranty or guarantee. Informal procedures such as "punch lists" are not to be deemed final or conditional acceptance.

19. TERMINATION FOR CAUSE & DAMAGES FOR DELAY

- A. If the Contractor refuses or fails to prosecute the work with such diligence as will insure its completion within the time specified in this Contract or any extension thereof, or fails to complete said work within such time, the Board of Supervisors may, by written notice to the Contractor, terminate his right to proceed with the work or such part of the work as to which there has been delay. In such event, the County may take over the work and prosecute the same to completion, by contract or otherwise, and may take possession of and utilize in completing the work such materials, appliances, and plant as may be on the site of the work and necessary therefore. Whether or not the Contractor's right to proceed with the work is terminated, Contractor and its sureties shall be liable for any damage to the County

resulting from his refusal or failure to complete the work within the specified time.

- B. If the County prosecutes the work to final completion as a result of Contractor's failure to prosecute the work or to otherwise comply with its obligations under this Contract including, but not limited to situations in which the County so terminates the Contractor's right to proceed in accordance with this section, the resulting damage will consist of fixed and agreed liquidated damages provided for in this Contract, until such reasonable time as may be required for final completion of the work together with any increased costs occasioned the County in completing the work.
- C. The Contractor's right to proceed shall not be so terminated nor the Contractor charged with resulting damage if:
- (1) The delay in the completion of the work arises from causes beyond the control and without the fault or negligence of the Contractor, including, but not restricted to, acts of God, acts of the public enemy, acts of the County, acts of another contractor in the performance of a contract with the County, fires, floods, epidemics, quarantine restrictions, strikes, freight embargoes, other than normal weather, or delays of subcontractors or suppliers arising from causes beyond the control and without the fault or negligence of both the Contractor and such subcontractors or suppliers; and
 - (2) The Contractor, within ten days from the beginning of any such delays (unless the County grants a further period of time before the date of final payment under the Contract), notifies OC Public Works in writing of the causes of delay.
- OC Public Works shall ascertain the facts and the extent of the delay and extend the time for completing the work when, in its judgment, the delay is justified. the County shall make written findings, and the findings of fact shall be final and conclusive on the parties, subject only to appeal as provided in Article 25 of these General Conditions.
- D. The rights and remedies of the County provided in this Article are in addition to any other rights and remedies provided by law or under this Contract.

20. TERMINATION FOR CONVENIENCE OF THE COUNTY

Notwithstanding any other provision of the Contract, the County may, at any time, and without cause, terminate this Contract in whole or in part, upon not less than seven (7) days' written notice to the Contractor. Such termination shall be effected by delivery to the Contractor of a notice of termination specifying the effective date of the termination and the extent of the Work to be terminated. The Contractor shall immediately stop work in accordance with the notice and comply with any other direction as may be specified in the notice or as provided subsequently by the County. The County shall pay the Contractor for the Work completed prior to the effective date of the termination, and such payment shall be Contractor's sole remedy under this Contract. Under no circumstances will the Contractor be entitled to anticipatory or unearned profits, consequential damages, or other damages of any sort as a result of a termination or partial termination under this Article. The Contractor shall insert in all subcontracts that the sub-consultant shall stop work on the date of and to the extent specified in a notice of termination and shall require sub-consultants to insert the same condition in any lower tier subcontracts.

21. BENEFICIAL OCCUPANCY

- A. The County may, at any time, and from time to time, during the performance of the work, enter the structure for the purpose of installing any necessary work by County labor or other contracts, and for any other purposes in connection with the installation of facilities. In doing so, the County shall endeavor not to interfere with the Contractor and the Contractor shall not interfere with other work

being done by or on behalf of the County.

- B. If, prior to completion and final acceptance of all the work, the County takes possession of any structure (whether completed or otherwise) comprising a portion of the work with the intent of retaining possession thereof (as distinguished from temporary possession contemplating the return to the Contractor), then, while the County is in possession of the same, the Contractor, notwithstanding his normal responsibilities, shall be relieved of liability for loss or damage to structure other than that resulting from the Contractor's fault or negligence. Such taking of possession by the County shall not relieve the Contractor from any provisions of this Contract respecting such structure, other than to the extent specified in the preceding sentence, nor constitute a final acceptance of such structure.

22. PATENT INFRINGEMENT

- A. The Contractor shall report to the County, promptly and in reasonable detail, each notice or claim of patent infringement based on the performance of this Contract of which the Contractor has knowledge.
- B. In the event of any suit against the County, or any claim against the County made before suit has been instituted, on account of any alleged patent infringement arising out of the performance of this Contract, or out of the use of any supplies furnished or work or Tasks performed hereunder, the Contractor shall, at his own expense, furnish to the County, upon request, all evidence and information in possession of the Contractor pertaining to such suit or claim. The Contractor further agrees to indemnify, defend with counsel approved in writing by County and hold harmless the County against any and all claims or lawsuits based upon such patent infringement, to defend such suits, and to pay any judgment rendered against County, its employees, or the Board of Supervisors.

23. NO WAIVER BY COUNTY

The failure of the County in any one or more instances to insist upon strict performance of any of the terms of this Contract or to exercise any option herein conferred, shall not be construed as a waiver or relinquishment to any extent of the right to assert or rely upon any such terms or option on any future occasion.

24. DISPUTES

- A. In the event of a dispute between the parties as to performance of the work, the interpretation of this Contract, or payment or nonpayment for work performed, the parties shall attempt to resolve the dispute. Pending resolution of the dispute, the Contractor shall continue the work diligently to completion as directed by the County. If the dispute is not resolved, the Contractor agrees he will neither rescind this Contract nor stop the progress of the work.
- B. For claims in excess of \$375,000, the following applies: "Claim" means a separate demand by a contractor sent by registered mail or certified mail with return receipt requested, for one or more of the following: a time extension, including, without limitation, for relief from damages or penalties for delay assessed by a public entity under a contract for a public works project; payment by the public entity of money or damages arising from work done by, or on behalf of, the contractor pursuant to the contract for a public works project and payment for which is not otherwise expressly provided or to which the claimant is not otherwise entitled; payment of an amount that is disputed by the public entity.

Pursuant to Public Contract Code Section 9204:

- (d)(1)(A) Upon receipt of a claim pursuant to this section, the public entity to which the claim applies shall conduct a reasonable review of the claim and, within a period not to exceed 45 days, shall provide the claimant a written statement identifying what portion of the claim is disputed and what portion is undisputed. Upon receipt of a claim, a public entity and a

contractor may, by mutual agreement, extend the time period provided in this subdivision.

- (B) The claimant shall furnish reasonable documentation to support the claim.
 - (C) If the public entity needs approval from its governing body to provide the claimant a written statement identifying the disputed portion and the undisputed portion of the claim, and the governing body does not meet within the 45 days or within the mutually agreed to extension of time following receipt of a claim sent by registered mail or certified mail, return receipt requested, the public entity shall have up to three days following the next duly publicly noticed meeting of the governing body after the 45-day period, or extension, expires to provide the claimant a written statement identifying the disputed portion and the undisputed portion.
 - (D) Any payment due on an undisputed portion of the claim shall be processed and made within 60 days after the public entity issues its written statement. If the public entity fails to issue a written statement, Article (3) shall apply.
- (2) (A) If the claimant disputes the public entity's written response, or if the public entity fails to respond to a claim issued pursuant to this section within the time prescribed, the claimant may demand in writing an informal conference to meet and confer for settlement of the issues in dispute. Upon receipt of a demand in writing sent by registered mail or certified mail, return receipt requested, the public entity shall schedule a meet and confer conference within 30 days for settlement of the dispute.
- (B) Within 10 business days following the conclusion of the meet and confer conference, if the claim or any portion of the claim remains in dispute, the public entity shall provide the claimant a written statement identifying the portion of the claim that remains in dispute and the portion that is undisputed. Any payment due on an undisputed portion of the claim shall be processed and made within 60 days after the public entity issues its written statement. Any disputed portion of the claim, as identified by the contractor in writing, shall be submitted to nonbinding mediation, with the public entity and the claimant sharing the associated costs equally. The public entity and claimant shall mutually agree to a mediator within 10 business days after the disputed portion of the claim has been identified in writing. If the parties cannot agree upon a mediator, each party shall select a mediator and those mediators shall select a qualified neutral third party to mediate with regard to the disputed portion of the claim. Each party shall bear the fees and costs charged by its respective mediator in connection with the selection of the neutral mediator. If mediation is unsuccessful, the parts of the claim remaining in dispute shall be subject to applicable procedures outside this section.
 - (C) For purposes of this section, mediation includes any nonbinding process, including, but not limited to, neutral evaluation or a dispute review board, in which an independent third party or board assists the parties in dispute resolution through negotiation or by issuance of an evaluation. Any mediation utilized shall conform to the timeframes in this section.
 - (D) Unless otherwise agreed to by the public entity and the contractor in writing, the mediation conducted pursuant to this section shall excuse any further obligation under Section 20104.4 to mediate after litigation has been commenced.
 - (E) This section does not preclude a public entity from requiring arbitration of disputes under private arbitration or the Public Works Contract Arbitration Program, if mediation under this section does not resolve the parties' dispute.

- (3) Failure by the public entity to respond to a claim from a contractor within the time periods described in this subdivision or to otherwise meet the time requirements of this section shall result in the claim being deemed rejected in its entirety. A claim that is denied by reason of the public entity's failure to have responded to a claim, or its failure to otherwise meet the time requirements of this section, shall not constitute an adverse finding with regard to the merits of the claim or the responsibility or qualifications of the claimant.
- (4) Amounts not paid in a timely manner as required by this section shall bear interest at 7 percent per annum.
- (5) If a subcontractor or a lower tier subcontractor lacks legal standing to assert a claim against a public entity because privity of contract does not exist, the contractor may present to the public entity a claim on behalf of a subcontractor or lower tier subcontractor. A subcontractor may request in writing, either on his or her own behalf or on behalf of a lower tier subcontractor, that the contractor present a claim for work which was performed by the subcontractor or by a lower tier subcontractor on behalf of the subcontractor. The subcontractor requesting that the claim be presented to the public entity shall furnish reasonable documentation to support the claim. Within 45 days of receipt of this written request, the contractor shall notify the subcontractor in writing as to whether the contractor presented the claim to the public entity and, if the original contractor did not present the claim, provide the subcontractor with a statement of the reasons for not having done so.

Upon receipt of a claim, the parties may mutually agree to waive, in writing, mediation and proceed directly to the commencement of a civil action or binding arbitration, as applicable.

- C. For claims of \$375,000 or less, the following applies: "Claim" means a separate demand by the Contractor for a time extension; payment of money or damages arising from work done by, or on behalf of, the Contractor pursuant to the Contract for public work and payment of which is not otherwise expressly provided for or the claimant is not otherwise entitled to; or an amount the payment of which is disputed by the County.

Pursuant to Public Contract Code Section 20104.2:

- (a) The claim shall be in writing and include the documents necessary to substantiate the claim. Claims must be filed on or before the date of final payment. Nothing in this subdivision is intended to extend the time limit or supersede notice requirements otherwise provided by contract for the filing of claims.
- (b)(1) For claims of less than fifty thousand dollars (\$50,000), the local agency shall respond in writing to any written claim within 45 days of receipt of the claim, or may request, in writing, within 30 days of receipt of the claim, any additional documentation supporting the claim or relating to defenses to the claim the local agency may have against the claimant.
 - (2) If additional information is thereafter required, it shall be requested and provided pursuant to this subdivision, upon mutual agreement of the local agency and claimant.
 - (3) The local agency's written response to the claim, as further documented, shall be submitted to the claimant within 15 days after receipt of the further documentation or within a time no greater than that taken by the claimant in producing the additional information, whichever is greater.
- (c) (1) For claims of over fifty thousand dollars (\$50,000) and less than or equal to three hundred seventy-five thousand dollars (\$375,000), the local agency shall respond in writing to

all written claims within 60 days of receipt of the claim, or may request, in writing, within 30 days of receipt of the claim, any additional documentation supporting the claim or relating to defenses to the claim the local agency may have against the claimant.

- (2) If additional information is thereafter required, it shall be requested and provided pursuant to this subdivision, upon mutual agreement of the local agency and the claimant.
- (3) The local agency's written response to the claim, as further documented, shall be submitted to the claimant within 30 days after receipt of the further documentation, or within a time no greater than that taken by claimant in producing the additional information or requested documentation, whichever is greater.
- (d) If claimant disputes the local agency's written response, or the local agency fails to respond within the time prescribed, the claimant may so notify the local agency, in writing, either within 15 days of receipt of the local agency's response or within 15 days of the local agency's failure to respond within the time prescribed, respectively, and demand an informal conference to meet and confer for settlement of the issues in dispute. Upon a demand, the local agency shall schedule a meet and confer conference within 30 days for settlement of the dispute.
- (e) Following the meet and confer conference, if the claim or any portion remains in dispute, the claimant may file a claim as provided in Chapter 1 (commencing with Section 900) and Chapter 2 (commencing with Section 910) of Part 3 of Division 3.6 of Title 1 of the Government Code. For purposes of those provisions, the running of the period of time within which a claim must be filed shall be tolled from the time the claimant submits his or her written claim pursuant to subdivision (a) until the time the claim is denied as a result of the meet and confer process, including any period of time utilized by the meet and confer process.
- (f) This article does not apply to tort claims and nothing in this article is intended nor shall be construed to change the time periods for filing tort claims or actions specified by Chapter 1(commencing with Section 900) and Chapter 2 (commencing with section 910) of Part 3 of Division 3.6 of Title 1 of the Government Code.

- D. Notwithstanding the foregoing, with respect to any dispute involving a claim by the Contractor for additional compensation, Contractor shall submit such claim in writing to County promptly as the alleged facts giving rise to, or the alleged bases for, the claim become known to the Contractor; any such claim not promptly so submitted to County shall be deemed waived; and in no event shall a claim for additional compensation be asserted or be assertable after completion or cessation of the work.

25. WAGE RATE PENALTY

Pursuant to the provisions of Section 1775 of the Labor Code, the Contractor shall forfeit to the County, as a penalty, the sum of Fifty Dollars (\$50) for each calendar day, or portion thereof, for each laborer, worker, or mechanic employed, paid less than the stipulated prevailing rates for any work done under this Contract, by him or by any subcontractor under him, in violation of the provisions of this Contract.

26. PAYROLL RECORDS

Contractor and any Subcontractor(s) shall comply with the requirements of Labor Code Section 1776. Such compliance includes the obligation to furnish the records specified in Section 1776 directly to the Labor Commissioner in an electronic format, or other format as specified by the Commissioner, in the manner provided by Labor Code Section 1771.4.

The requirements of Labor Code Section 1776 provide, in summary:

- 1.1.1. Contractor and any Subcontractor(s) performing any portion of the work under this Contract shall keep an accurate record, showing the name, address, social security number, work classification, straight time and overtime hours worked each day and week, and the actual per diem wages paid to each journeyman, apprentice, worker, or other employee employed by Contractor or any Subcontractor(s) in connection with the work.
- 1.1.2. Each payroll record shall contain or be verified by a written declaration that it is made under penalty of perjury, stating both of the following:
 - (a) The information contained in the payroll record is true and correct.
 - (b) The employer has complied with the requirements of Labor Code Sections 1771, 1811, and 1815 for any work performed by his or her employees in connection with the Contract.
- 1.1.3. The payroll records shall be certified and shall be available for inspection at the principal office of Contractor on the basis set forth in Labor Code Section 1776.
- 1.1.4 Contractor shall inform County of the location of the payroll records, including the street address, city and county, and shall, within five working days, provide a notice of any change of location and address of the records.
- 1.1.5. Pursuant to Labor Code Section 1776, Contractor and any Subcontractor(s) shall have 10 days in which to provide a certified copy of the payroll records subsequent to receipt of a written notice requesting the records described herein. In the event that Contractor or any Subcontractor fails to comply within the 10-day period, he or she shall, as a penalty to County, forfeit \$100, or a higher amount as provided by Section 1776, for each calendar day, or portion thereof, for each worker to whom the noncompliance pertains, until strict compliance is effectuated. Contractor acknowledges that, without limitation as to other remedies of enforcement available to County, upon the request of the Division of Apprenticeship Standards or the Division of Labor Standards Enforcement of the California Department of Industrial Relations, such penalties shall be withheld from progress payments then due Contractor. Contractor is not subject to a penalty assessment pursuant to this section due to the failure of a subcontractor to comply with this section.

Contractor and any Subcontractor(s) shall comply with the provisions of Labor Code Sections 1771 et seq., and shall pay workers employed on the Contract not less than the general prevailing rates of per diem wages and holiday and overtime wages as determined by the Director of Industrial Relations. Contractor shall post a copy of these wage rates at the job site for each craft, classification, or type of worker needed in the performance of this Contract, as well as any additional job site notices required by Labor Code Section 1771.4(b). Copies of these rates are on file at the principal office of County's representative, or may be obtained from the State Office, Department of Industrial Relations ("DIR") or from the DIR's website at www.dir.ca.gov. If the Contract is federally funded, Contractor and any Subcontractor(s) shall not pay less than the higher of these rates or the rates determined by the United States Department of Labor.

27. WORK HOUR PENALTY

Eight hours of labor constitute a legal day's work, and forty hours constitute a legal week's work. Pursuant to Section 1813 of the Labor Code of the State of California, the Contractor shall forfeit to the County Twenty Five Dollars (\$25) for each worker employed in the execution of this Contract by the Contractor or by any subcontractor for each calendar day during which such worker is required or permitted to work more than the legal day's or week's work, except that work performed by employees of said Contractor and subcontractors in excess of the legal limit shall be permitted without the foregoing penalty upon the payment of compensation to the workers for all hours worked in excess of eight hours per day of not less than 1-1/2 times the basic rate of pay.

28. APPRENTICES

- A. The Contractor acknowledges and agrees that, if this Contract involves a dollar amount greater than or a number of working days greater than that specified in Labor Code Section 1777.5, this Contract is governed by the provisions of Labor Code Section 1777.5. It shall be the responsibility of the Contractor to ensure compliance with this Article and with Labor Code Section 1777.5 for all apprenticeable occupations.
- B. Pursuant to Labor Code Section 1777.5 if that Section applies to this Contract as indicated above, the Contractor and any subcontractors under him employing workers in any apprenticeable craft or trade in performing any work under this Contract shall apply to the applicable joint apprenticeship committee for a certificate approving the Contractor or subcontractor under the applicable apprenticeship standards and fixing the ratio of apprentices to journeymen employed in performing the work.
- C. Pursuant to Labor Code Section 1777.5 if that Section applies to this Contract as indicated above, he Contractor and any subcontractor under him may be required to make contributions to the apprenticeship program.
- D. The Contractor and all subcontractors under him shall comply with Labor Code Section 1777.6 which Section forbids certain discriminatory practices in the employment of apprentices.

29. NON-DISCRIMINATION

In the performance of the terms of this Contract, Contractor agrees that it will not engage in nor permit such subcontractors as it may employ to engage in discrimination against any employee or applicant for employment on the basis of race, sex, color, religion, ancestry, national origin, marital status, age or as an otherwise qualified handicapped individual. This prohibition shall pertain to employment, upgrading, demotion, or transfer; recruitment advertising; layoff or termination; rates of pay and other forms of compensation; selection for training, including apprenticeship; and any other action or inaction pertaining to employment matters.

30. ASSIGNMENT OF ANTITRUST ACTIONS

In accordance with Public Contract Code, Section 7103.5, by entering into this contract or into a subcontract to supply goods, Tasks, or materials pursuant to this Contract, the Contractor, or subcontractor, offers and agrees to assign to the County all rights, title, and interest in and to all causes of action it may have under Section 4 of the Clayton Act (15 U.S.C. Sec. 15) or under the Cartwright Act (Chapter 2 [commencing with Section 16700] of Part 2 of Division 7 of the Business and Professions Code), arising from purchases of goods, Tasks, or materials pursuant to this Contract or the subcontract. This assignment shall be made and become effective at the time the County tender's final payment to the Contractor, without further acknowledgment by the parties. The Contractor shall cause to be inserted in any such subcontract stipulations to effectuate this Article and the provisions of Public Contract Code, Section 7103.5.

31. SUBSTITUTED SECURITY

In accordance with Section 22300 of the Public Contract Code, the Director will, at the request and expense of the Contractor, accept securities equivalent to any amount withheld by the County to ensure performance under this Contract, including, but not limited to, the amount withheld under Articles 5 and 8 of the Contract. Such substituted security must meet the requirements of said Section 22300 and shall be deposited with a California or federally chartered bank as escrow agent. The security shall be held by the escrow agent subject to a written escrow agreement between County, Contractor, and escrow agent, which agreement shall be in a form substantially similar to that contained in Public Contract Code, Section 22300.

32. COST REDUCTION INCENTIVE

- A. Contractor may submit to the County written proposals for modifying the plans, specifications, or other requirements of this Contract for the sole purpose of reducing the total cost of construction. The cost reduction proposal shall not impair, in any manner, the essential functions or characteristics of the Project, including, but not limited to Task life, economy of operation, ease of maintenance, desired appearance, or design and safety standards.
- B. Cost reduction proposals shall contain the following information:
- (1) A description of both the existing Contract requirements for performing the work and the proposed changes;
 - (2) An itemization of the Contract requirements that must be changed if the proposal is adopted;
 - (3) A detailed estimate of the cost of performing the work under the existing Contract and under the proposed change;
 - (4) A prediction of the effects the proposed change would, if adopted, have on other costs to the County, such as County furnished property costs, costs of future construction, and costs of maintenance and operation; and
 - (5) A statement of the time by which a Change Order adopting the proposal must be issued in order to obtain the maximum cost reduction.
- C. The provisions of this Article shall not be construed to require the County to consider any cost reduction proposal which may be submitted hereunder; the County will not be liable to the Contractor for failure to accept or act upon any cost reduction proposal submitted pursuant to this Article; and the County will not be liable to the Contractor for any delays to the work attributable to any such proposal. If a cost reduction proposal is similar to a change in the plans or specifications which change is under consideration by OC Public Works or by the County for the Project at the time said proposal is submitted, or if such a proposal is based upon or similar to standard specifications, standard special provisions or standard plans adopted by the County after the advertisement for the Contract, the County will not accept such proposal and the County reserves the right to make such changes without compensation to the Contractor under the provisions of this Article
- E. The Contractor shall continue to perform the work in accordance with the requirements of the Contract until an executed Change Order incorporating the cost reduction proposal has been issued. If an executed Change Order has not been issued by the date upon which the Contractor's cost reduction proposal specifies that a decision thereon should be made, or such other date as the Contractor may subsequently have specified in writing, such cost reduction proposal shall be deemed rejected.
- F. The County shall be sole judge of the acceptability of a cost reduction proposal and of the estimated net savings in construction costs from the adoption of all or any part of such proposal. In determining the estimated net savings, the right is reserved to the County to disregard the Contract bid prices if in the judgment of the County such prices do not represent a fair measure of the value of work to be performed or to be deleted. The decision of the County as to acceptance or rejection of such proposal, and as to the estimated net savings in construction costs, shall not be subject to the "Disputes" Article of the General Conditions to this Contract, above.
- F. The County reserves the right to require the Contractor to pay the County's costs of investigating a cost reduction proposal submitted by the Contractor as a condition of considering such proposal. Where such a condition is imposed, the Contractor shall indicate its acceptance thereof in writing, and

such acceptance shall constitute full authority for the County to deduct amounts thereby payable to the County from any monies due to or that may become due to the Contractor under the Contract.

- G. If the Contractor's cost reduction proposal is accepted in whole or in part such acceptance will be by a Change Order, which shall specifically state that it is executed pursuant to this Article. Such Change Order shall incorporate the changes in the plans and specifications which are necessary to permit the cost reduction proposal or such part of it as has been accepted to be put into effect, and shall include any conditions on which County's approval is based if the approval of the County is conditional. The Change Order shall also set forth the estimated net savings in the cost of performing the work attributable to the cost reduction proposal effectuated by the Change Order and shall further provide that the Contractor be paid 50 percent of said estimated net savings amount.
- H. Acceptance of the cost reduction proposal and performance of the work thereunder shall not extend the time for completion of the Contract unless such extension is specifically provided for in the Change Order authorizing the use of the cost reduction proposal.
- I. The amount specified to be paid to the Contractor in the Change Order which effectuates a cost reduction proposal shall constitute full compensation to the Contractor for the cost reduction proposal and for the performance of the work thereunder pursuant to the said Change Order
- J. The County expressly reserves the right to adopt a cost reduction proposal for general use on contracts let or administered by the County when it determines that said proposal is suitable for application to other contracts. When an accepted cost reduction proposal is adopted for general use, only the Contractor who first submitted such proposal will be eligible for compensation pursuant to this Article, and, in that case, only as to those contracts awarded to it prior to submission of the accepted cost reduction proposal and as to which such cost reduction proposal is also submitted and accepted. Cost reduction proposals identical or similar to previously submitted proposals will be eligible for consideration and compensation under the provisions of this Article if the identical or similar previously submitted proposals were not adopted for general application to other contracts let or administered by the County. Subject to the provisions contained herein, the State or any other public entity shall have the right to use all or any submitted cost reduction proposal without obligation or compensation of any kind to the Contractor.

33. WRITTEN NOTICE

Any written notice required to be given in any part of the Contract documents shall be performed by depositing the same in the U.S. Mails, postage prepaid, directed to the address of the Contractor as set forth in the contract documents, and to the County addressed as follows:

COUNTY:

Agency Name: Orange County Information Technology
 Program Manager
 Attn: KC Roestenberg
 Phone: (714) 567-5075
 Email: KC.Roestenberg@ocit.oc.gov

Agency Name: Orange County Information Technology
 Procurement Operations Manager
 Attn: Tim Shears, MA, DPA
 Phone: (714)567-7488
 Email: Timothy.Shears@ocit.ocgov.com

CONTRACTOR: West Coast Cable, Inc.

Attn: Henry J. Wejeik

Phone: 909-592-8708

Email: ~~henry.w@West-Coast-Cable.us.com~~

Attn: John A. Haygood

Phone: 909-364-9906

Email: jahaygood@wccable.com